

HUSQVARNA AUTOMOWER®
210 C
OPERATOR'S MANUAL

TABLE OF CONTENTS

1. Introduction and safety	5
1.1 Introduction	5
1.2 Symbols on Automower®	6
1.3 Symbols in the Operator's Manual	7
1.4 Safety instructions	8
2. Presentation	10
2.1 Automower®, what's what?	11
2.2 Function of Automower®	12
2.3 One Automower® in several gardens	14
3. Installation	15
3.1 Preparations	15
3.2 Installation of the loop generator/charger	16
3.3 Charging the battery	17
3.4 Installation of the boundary wire	17
3.5 Connecting the boundary wire	24
3.6 Checking the installation	25
3.7 Linking Automower® to the loop generator/charger	26
4. Use	27
4.1 Starting Automower®	27
4.2 Stopping Automower®	27
4.3 Restart	28
4.4 Switching off Automower®	28
4.5 Using the Timer	28
4.6 Adjusting the cutting height	29
4.7 Changing the PIN code	30
4.8 Charging and storage between mowing	30
4.9 Sounds	31
5. Control panel	32
5.1 Select	32
5.2 Numbers	32
5.3 Main switch	33
5.4 Indicator lamps	33
6. Garden example	34
7. Maintenance	36
7.1 Battery	36
7.2 Winter storage	37
7.3 Service	37
7.4 Cleaning	38
7.5 Replacing the blades	39
7.6 Transport and moving	40
8. Trouble shooting	41
8.1 Fault messages	41
8.2 Fault symptom	43
9. Technical data	44
10. Environmental information	45
11. EU declaration of conformity	45

TABLE OF CONTENTS

Husqvarna AB has a policy of continuous product development and therefore reserves the right to modify the design and appearance and function of products without prior notice. This Operator's Manual deals with version 2.7x of the mower's control program.

1. Introduction and safety

1.1 Introduction

Congratulations on your choice of an exceptionally high quality product. To get the best results from your Husqvarna Automower® requires knowledge of its function. This Operator's manual contains important information about the mower, how you install it and how you use it.

The following system is used in the Operator's manual to make this easier:

- Text written in *italics* is a reference to another part of the Operator's Manual.
- Words written in **bold** are one of the buttons on the mower's keypad.
- Words written in *UPPERCASE* and *italics* refer to the position of the main switch and the different operating modes on the mower.

IMPORTANT INFORMATION

Read through the Operator's Manual carefully and understand the content before using your Automower®.



WARNING

Automower® can be dangerous if incorrectly used.

1. INTRODUCTION AND SAFETY

1.2 Symbols on Automower®

These symbols can be found on the lawn mower. Study them carefully so you understand their significance.

- Read through the Operator's Manual carefully and understand the content before using your Automower®.
- The warnings and safety instructions in this Operator's Manual must be carefully followed if the mower is to be used safely and efficiently.
- Automower® can only start when the main switch is moved to the *ON* position and the correct PIN code has been entered. Inspection and/or maintenance must be carried out with the main switch set to *OFF*.
- Keep your hands and feet away from the rotating blades. Never place your hands or feet close to or under the body when Automower® is in operation.
- Do not ride on Automower®.
- Noise emission to surroundings. The machine's emission is specified in chapter Technical data and on label.
- This product conforms to the applicable EU Directives.
- This product must be left at an appropriate recycling station.

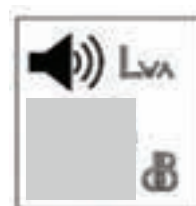
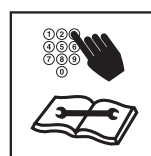

1. INTRODUCTION AND SAFETY

1.3 Symbols in the Operator's Manual

These symbols can be found in the Operator's Manual. Study them carefully so you understand their significance.

- Inspection and/or maintenance must be carried out with the main switch set to *OFF*.

ON



OFF

- Always wear protective gloves when working with the mower's underframe.



- Never use a high-pressure washer or even running water to clean Automower®.

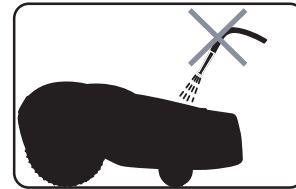

- A warning box indicates a risk of personal injury exist, especially when the stated instructions are not followed.



WARNING

Xxxxxx xxxxx xxxx xxxx xxxxx xxx.

- An information box indicates a risk of material damage exist, especially when the stated instructions are not followed. The box is also used where there is a risk of user error.

IMPORTANT INFORMATION

Xxxxxx xxxxx xxxx xxxx xxxxx xxx.

1. INTRODUCTION AND SAFETY

1.4 Safety instructions

Use

- Please read the Operator's Manual carefully and make sure you understand the instructions before using Automower®.



- It is not permitted to modify the original design of Automower®. All modifications are made at your own risk.
- Check that there are no stones, branches, tools, toys or other objects on the lawn that can damage the blades and cause the mower to stop.

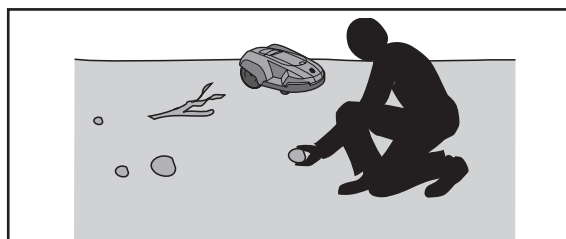

- Start Automower® according to the instructions.
When the main switch is in the *ON* position; make sure you keep your hands and feet away from the rotating blades. Never put your hands and feet under the mower.
- Never lift up the Automower® or carry it around when the main switch is in the *ON* position.
- Never lift up Automower® or carry it around when it is running.
- Do not let persons who do not know how Automower® works and behaves use the mower.
- Never use Automower® if persons, especially children, or pets, are in the immediate vicinity.
- Do not place objects on top of Automower®.
- Do not allow Automower® to be used with a defective blade disc or body. Neither should it be used with defective blades, screws, nuts or cables.
- Do not use Automower® if the main switch does not work.
- Always switch off Automower® using the main switch when you do not intend to use the mower. Automower® can only start when the main switch is moved to the *ON* position and the correct PIN code has been entered.
- Husqvarna AB does not guarantee full compatibility between Automower® and other types of wireless systems such as remote controls, radio transmitters, buried electric animal fencing or similar.



1. INTRODUCTION AND SAFETY

Transport

The original packaging should be used when transporting Automower® over long distances.

To safely move from or within the working area:

1. Move the main switch to the *OFF* position if you intend to carry the mower.

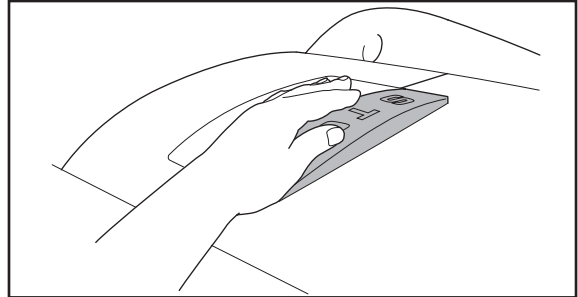

2. Carry the mower by the handle at the rear of the mower. Carry the mower with the blade disc away from the body.

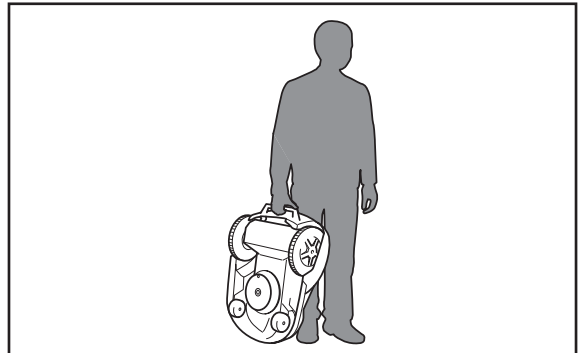

Maintenance



WARNING

When the mower is turned upside down the main switch must always be set to the *OFF* position.

The main switch should be set to the *OFF* position during all work on the mower's underframe, such as cleaning or replacing the blades.

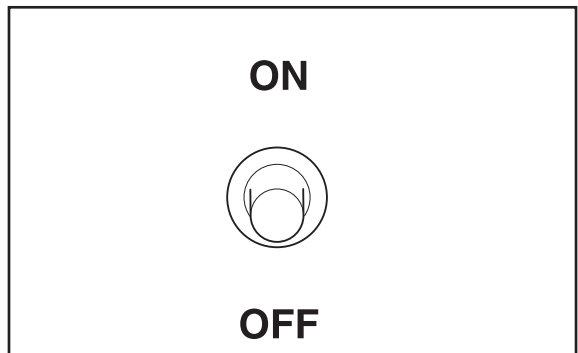

- Inspect Automower® each week and replace any damaged or worn parts.

Check especially that the blades and blade disc are not damaged. Replace all blades and screws at the same time if necessary so that the rotating parts are balanced, see *7. Maintenance* on page 38.

2. PRESENTATION

2. Presentation

This chapter contains information you should be aware of when planning the installation.

An installation of Husqvarna Automower® comprises three main components:

Automower®, an automatic lawn mower that mows the lawn by moving in an irregular pattern. The mower is powered by a maintenance-free battery.

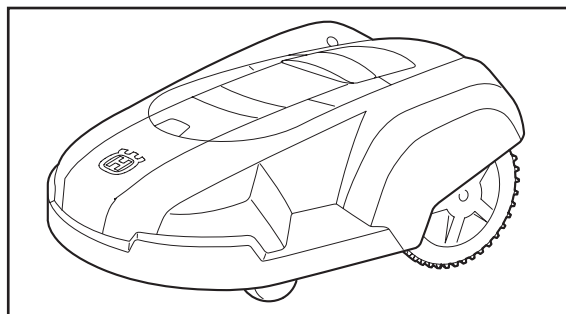

Loop generator/charger.

The loop generator/charger has two functions:

- To send control signals along the boundary wire.
- To charge the battery in Automower®.

The loop generator/charger is connected to a 230 V wall socket via an integrated power cord and to the mower via a 2 m long low voltage cable.

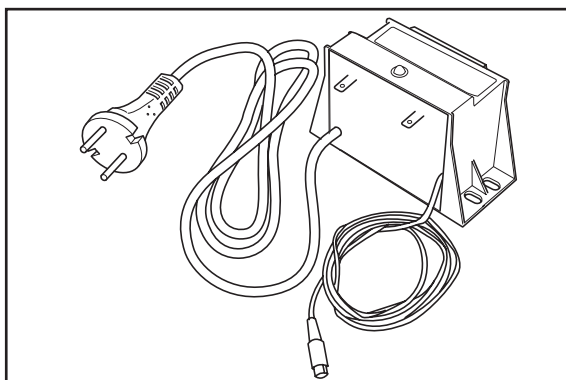

Wire, laid in a loop around Automower®'s working area. The boundary wire is laid around the edges of the lawn and around objects and plants that the mower must not run into.

The wire supplied with the installation is 150 m long. If this is not sufficient more wire can be purchased, with a connector, and spliced onto the existing wire.

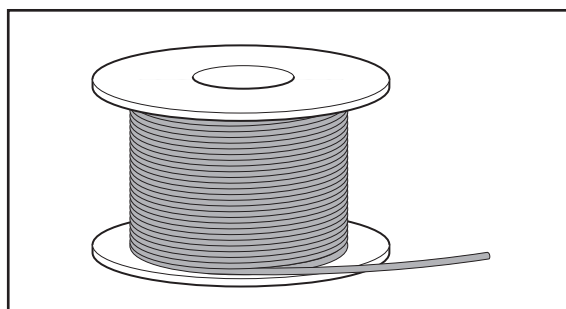

2. PRESENTATION

2.1 Automower®, what's what?

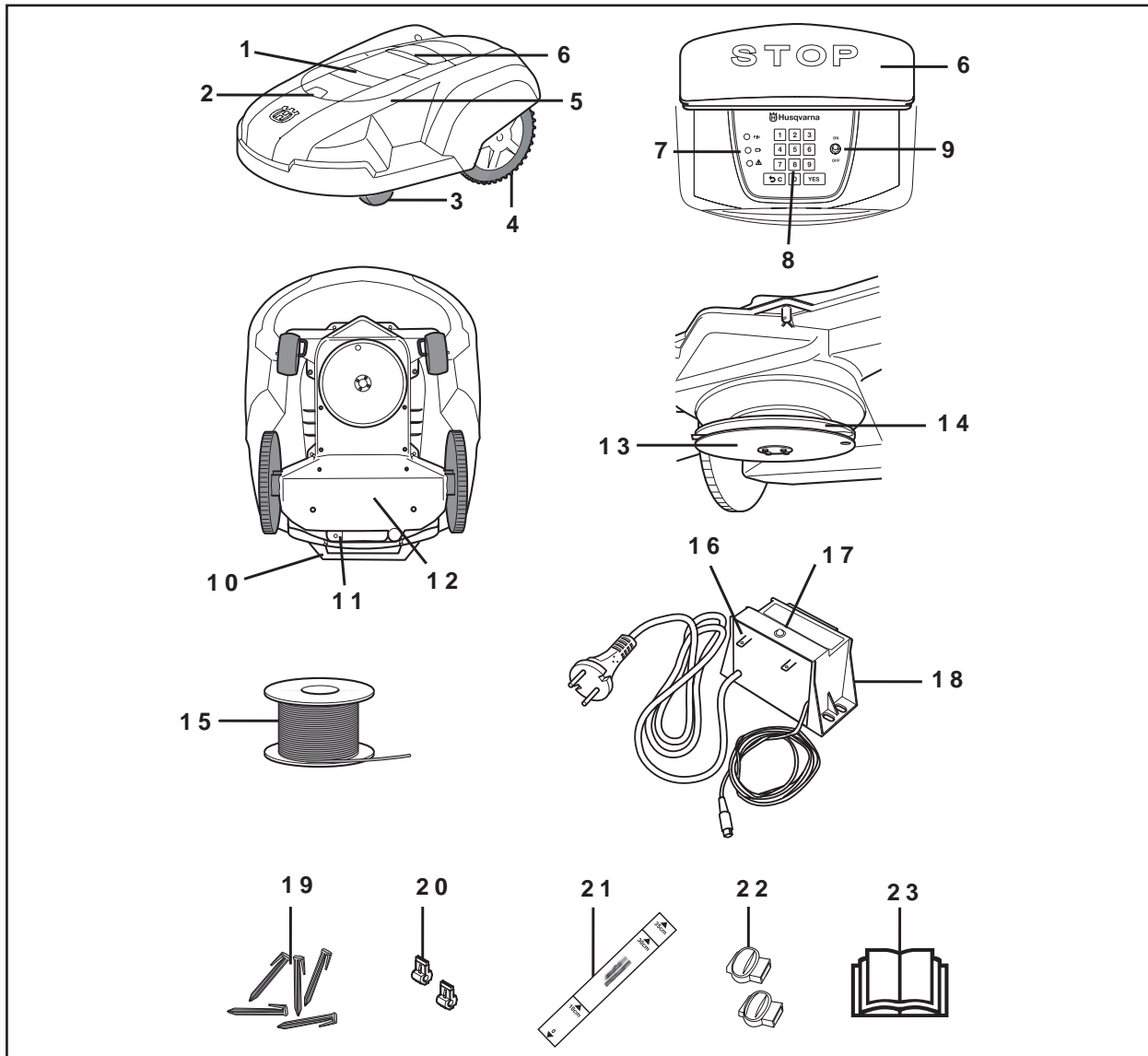

The numbers in the picture correspond to:

- | | |
|---|--|
| 1. Cutting height adjustment cover | 14. Blade disc |
| 2. Catch button to open the cutting height adjustment cover | 15. Loop wire for boundary wire |
| 3. Front wheel | 16. Connection to boundary wire |
| 4. Drive wheel | 17. LED for operation check of the boundary wire |
| 5. Body | 18. Loop generator/charger |
| 6. Stop button | 19. Staples |
| 7. Indicator lamps | 20. Connector for the loop wire |
| 8. Keypad | 21. Measurement gauge for help when installing the boundary wire |
| 9. Main switch | 22. Solderless coupler for the loop wire |
| 10. Handle | 23. Operator's Manual |
| 11. Charger contact | |
| 12. Chassis box with electronics, battery and motors | |
| 13. Skid plate | |

2. PRESENTATION

2.2 Function of Automower®

Capacity

Automower® is recommended for lawns up to 500 m². The size of the working area the mower can handle depends on how much it is used. The larger the lawn the more occasions per week the Automower® can work.

How large an area is mown per hour depends primarily on the condition of the blades and the type of grass, growth rate and humidity. The shape of the garden is also significant. If the garden mainly consists of open lawns, Automower® can mow more per hour than if the garden consists of several small lawns separated by trees, flower beds and passages.

Automower® must work several times a week for the lawn to be mown properly. If the grass is too tall when the mower starts to work the result will be poor. Neither is it advisable to allow Automower® to mow too often. If the mower works too much, the lawn will appear trampled down. How many times, and how long, the mower should work per week, is determined among others by the shape of the lawn, the length of the grass and the condition of the blades. If the lawn is 300 m² it is recommended to let Automower® mow three times a week. Match the use of Automower® to your garden.

How long Automower® mows and recharges can vary depending on, among others, the ambient temperature. Up to about 25°C a fully charged Automower® mows for approximately 2 - 3 hours, depending on the age of the battery and the thickness of the grass. It takes around 4 - 5 hours to fully charge the battery in the mower. The mowing time drops successively above 25°C.

If required, the mowing time can be increased by installing an additional battery. The mowing time then increases to approx. 4 - 6 hours. This also means that the charging time increases to approx. 5 - 7 hours. Please contact your dealer for more information.

Mowing technique

The mowing system used by Automower® is based on an effective and energy efficient principle. Unlike normal lawn mowers, Automower® cuts the grass instead of striking it off.

We recommend you allow Automower® to mainly mow in dry weather to obtain the best possible result. Automower® can even mow in the rain, however, wet grass easily collects on the mower and the risk of slipping on steep slopes is greater. To keep the drive wheels clean and thus increase traction, use Automower® wheel brushes (505 13 27-01).

2. PRESENTATION

When there is a risk of thunder Automower® should not stand in the charging station. When there is a risk of a thunder storm, the 230 V plug should be removed from the mains socket and the boundary wire disconnected from the charging station.

The blades must be in good condition to obtain the best mowing result. In order to keep the blades sharp for as long as possible it is important to keep the lawn free from branches, small stones and other objects.

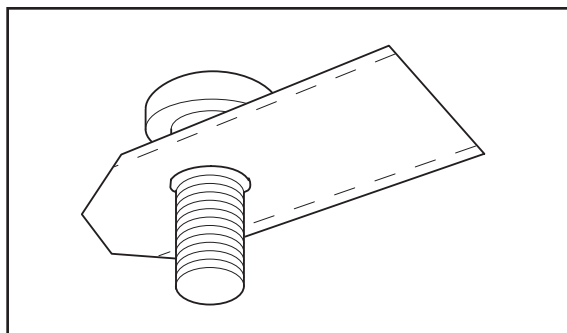

Working method

Automower® automatically mows the lawn.
Automower® automatically mows the lawn. When the battery is discharged the mower stops on the lawn, and you need to carry it to the loop generator/charger for charging.

When Automower® body hits an obstacle, the mower reverses and selects a new direction.

Two sensors, at the front and back on Automower®, sense when the mower approaches the boundary wire. Automower® overruns the wire by up to 27 centimetres before it turns.

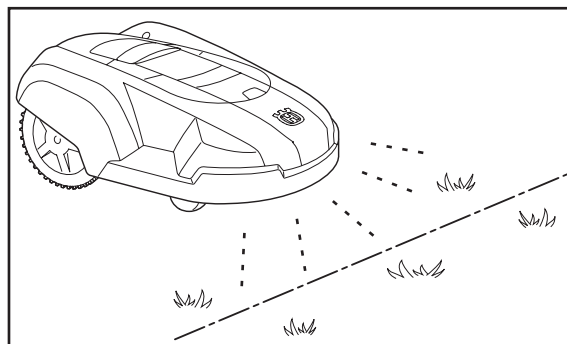

The **STOP** button on the top of Automower® is mainly used to stop the mower when it's running. When the **STOP** button is pressed a cover opens, behind which there is a control panel. The **STOP** button remains depressed until the cover is closed again. This acts as start inhibitor.

You start the mower via the control panel on top of Automower®. Open the control panel cover by pressing down the **STOP** button.

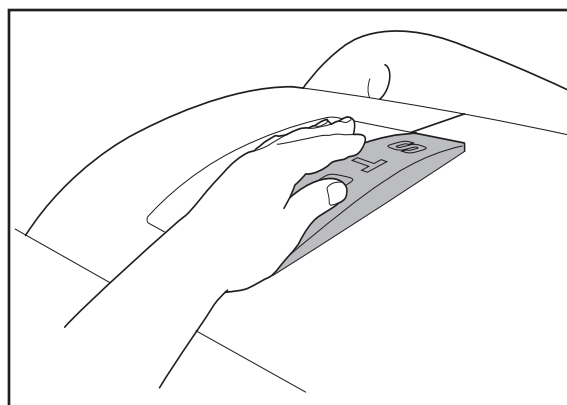

2. PRESENTATION

A four digit PIN code must be chosen and entered when the main switch is set in the *ON* position for the first time. (see page 30).

The chosen PIN code must then be entered each time the mower is started. If the mower does not start within 20 seconds the PIN code must be re-entered until the mower starts. Slide shut the cover to start the mower after the PIN code has been entered.

Automower® can, to save energy, enter sleep mode. The indicator lamps on the control panel are then turned off completely.

The sleep mode is activated 25 minutes after the **STOP** button has been pressed and then not reset to the operating mode. Automower® is then activated by switching the main switch off and on.

The sleep mode can also be activated in the event of a fault occurring during mowing or charging and which is not rectified within 25 minutes. Automower® is then activated by pressing the **STOP** button.

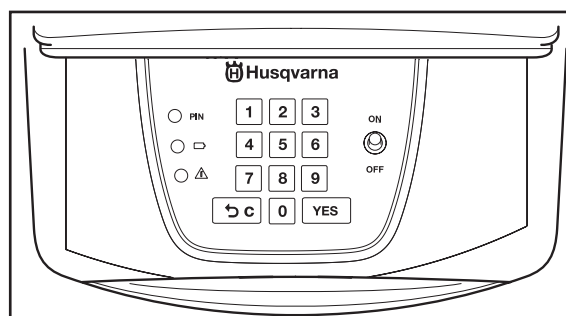

Movement pattern

The mower's movement pattern is irregular and is determined by Automower® itself. A movement pattern is never repeated. This mowing system means the lawn is mown equally without any mowing lines.

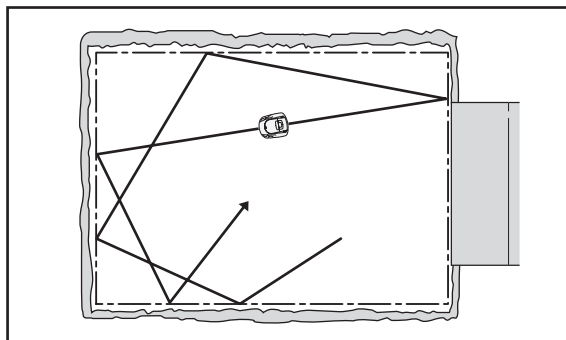

2.3 One Automower® in several gardens

One Automower® can easily be used for more than one garden, where each garden has its own loop generator/charger and boundary wire.

Contact your dealer for further information.

3. INSTALLATION

3. Installation

This chapter describes how you install Husqvarna Automower®. Before starting the installation read the previous chapter 2. *Presentation*.

Read the whole of this chapter too before starting the installation. How the installation is made also affects how well Automower® will work. It is therefore important to plan the installation carefully.

Planning is simplified if you make a sketch of the working area, including all obstacles. This makes it easier to see how the boundary wire should ideally be placed. Draw how the boundary wire is to be routed on the sketch.

Carry out the installation in the following steps:

- 3.1 Preparations.
- 3.2 Installation of the loop generator/charger
- 3.3 Charging the battery.
- 3.4 Installation of the boundary wire.
- 3.5 Connecting the boundary wire.
- 3.6 Checking the installation.
- 3.7 Linking Automower® to the loop generator/charger

In order to carry out a complete start-up of Automower® the loop generator/charger and boundary wire must be connected and the mower linked to the loop generator/charger. If you would like to start the mower without having completed the full boundary installation, you can connect a temporary short loop around the mower.

3.1 Preparations

1. If the lawn in the proposed working area is taller than 10 cm, mow it using a normal lawn mower. Then collect the clippings.

2. Read carefully through all the steps before the installation.

3. Check that all parts for the installation are included:

The numbers in brackets refer to the detail diagram 2.1 *Automower®*, *what's what?* on page 11.

- Operator's Manual (23)
- Automower®
- Loop generator/charger (18)
- Loop wire for the boundary wire (15)
- Staples (19)
- Connector for the loop wire (20)
- Measurement gauge (21)
- Solderless coupler for the loop wire (22)

During installation you will also need: A hammer to knock the staples into the ground, combination pliers, and a straight spade if the boundary wire is to be buried.

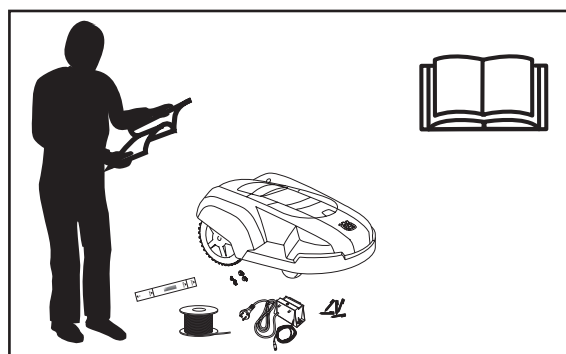

3. INSTALLATION

3.2 Installation of the loop generator/charger

The loop generator/charger must be placed where it is well ventilated and is not exposed to direct sunlight. The mower's battery is spared if it is charged in the lowest possible ambient temperature. It is also beneficial if the transformer can be placed under a roof.

IMPORTANT INFORMATION

The power cord for the loop generator/charger must not be replaced. If the power cord is damaged the loop generator/charger must be scrapped and replaced with a new unit.

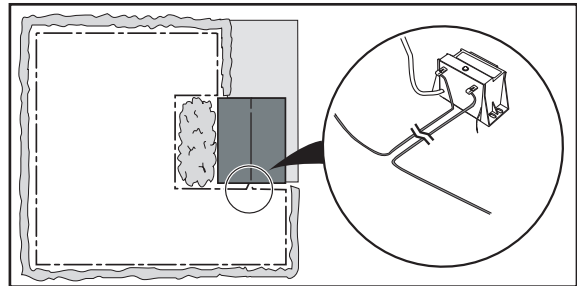

Consider the distance to a wall socket when choosing the position. The loop generator/charger must be connected to a 230 V wall socket and there must be room for the mower when it is to be charged.

It is recommended to use an earth fault-breaker when connecting the transformer to the wall socket.

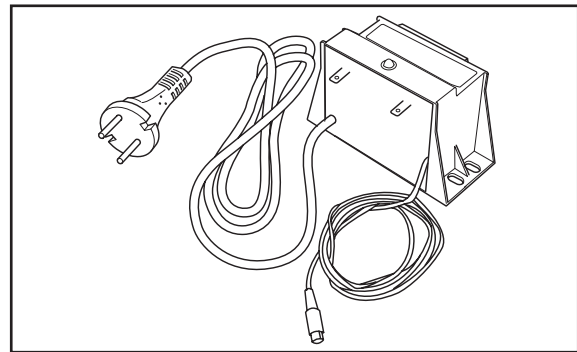

Tip! If, for reasons of space or for some other reason, it is not suitable to charge the mower where the loop generator/charger is positioned, a freestanding charger can also be used. A charger can be purchased as an accessory. Contact your dealer for further information.

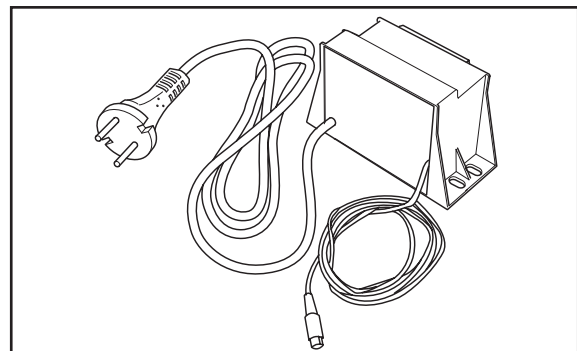

Installation and connecting the loop generator/charger

1. Position the loop generator/charger in a suitable spot.
2. Connect the loop generator/charger's power cord to a 230 V wall socket. It is preferable to use an earth-fault breaker as recommended.

3. INSTALLATION

3.3 Charging the battery

Automower® is supplied with an uncharged battery. As soon as the loop generator/charger is connected, it is possible to charge the mower.

1. Set the main switch to the *ON* position and leave the cover for the control panel open.
2. Connect the charger cable from the loop generator/charger to the charger contact on the mower. The green indicator lamp Battery now goes on. When the mower is fully charged the green indicator lamp goes off, and the yellow lamp starts flashing.

From an uncharged state the battery takes about 4 - 5 hours until it is fully charged.

Tip! Leave the mower connected to the charger cable when not in use. As long as the mower is connected it will be maintenance charged, which means the battery will be fully charged when the mower is used. This does not apply to winter storage, see 7.2 Winter storage on page 38.

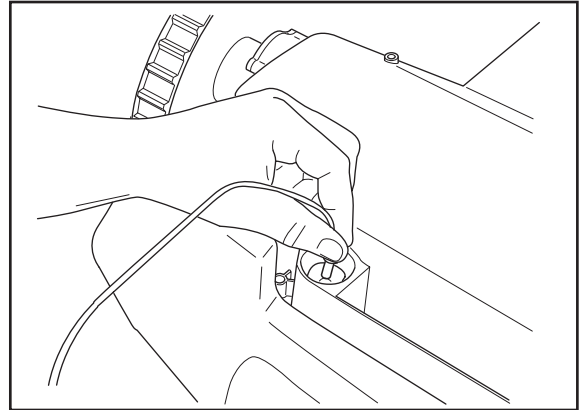

IMPORTANT INFORMATION

Automower® cannot be used before the installation is complete.

3.4 Installation of the boundary wire

The boundary wire can be installed in one of the following ways:

- Securing the wire to the ground with staples.
It is preferable to staple down the boundary cable, if you want to make adjustments to the boundary wire during the first few weeks of operation.
- Bury the wire.
It is preferable to bury the boundary wire if you want to dethatch or aerate the lawn.

If necessary both methods can be combined so one part of the boundary wire is stapled down and the remainder is buried.

3. INSTALLATION

Best position for the boundary wire

The boundary wire should be laid so it:

- Forms a loop around the working area for Automower®. Only an original boundary wire must be used. This is tinned and has a high quality insulation to withstand the dampness in the ground.
- Is a maximum of 350 metres long.
- Maintains a maximum distance of 25 metres from Automower® in the entire working area.
- The boundary wire is laid at different distances from obstacles depending on what the working area borders. The picture below shows how the boundary wire should be routed around the working area and around obstacles.

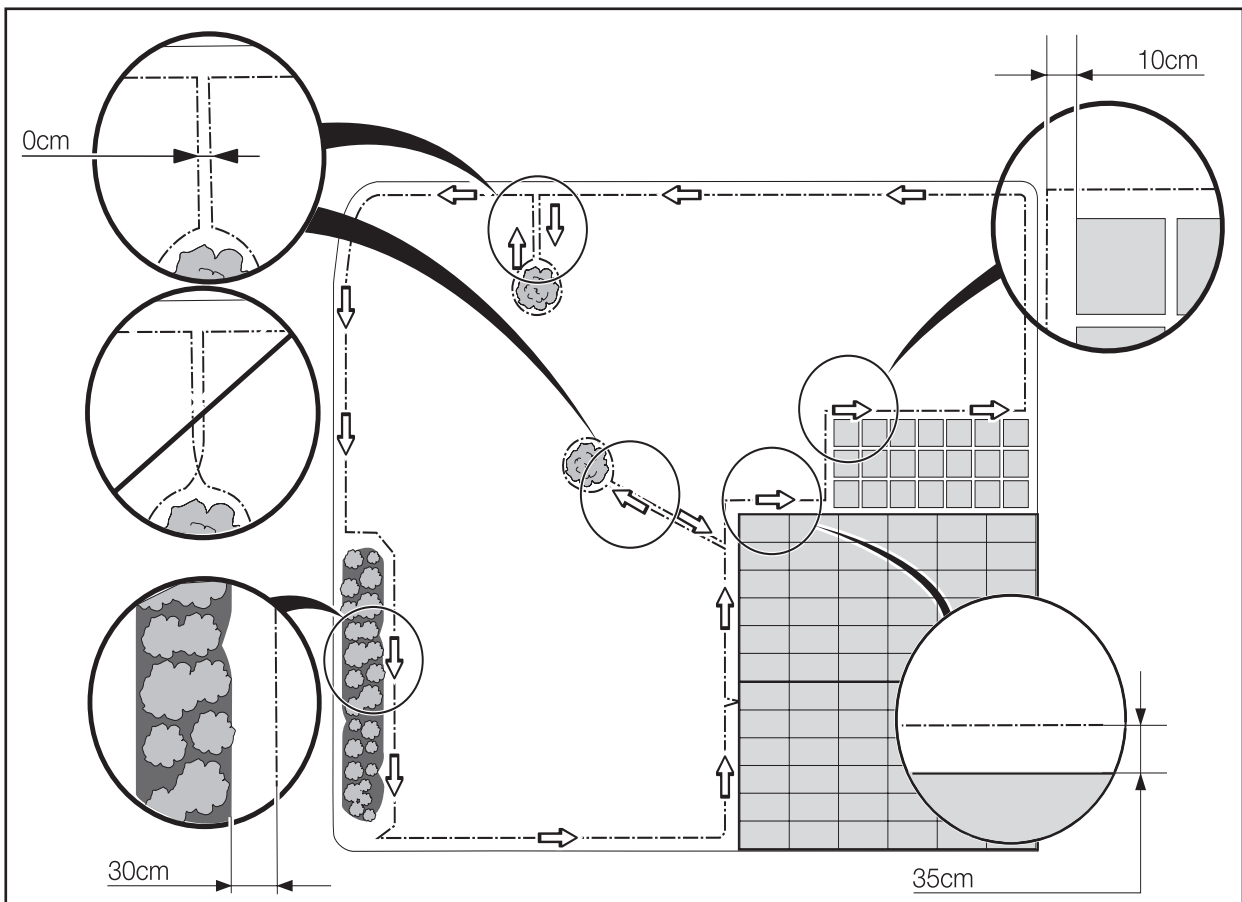

3. INSTALLATION

Boundaries for the working area

If a high obstacle, for example a wall or fence, borders the working area, the boundary wire should be laid 35 cm from the obstacle. This will prevent Automower® from colliding with the obstacle and reduce body wear.

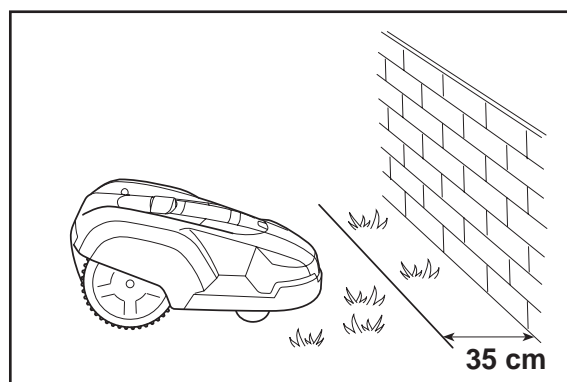

If the working area borders against a small ditch, for example, a flower bed or a small elevation, e.g. a low verge (3 - 5 cm), the boundary wire should be laid 30 cm inside the working area. This prevents the wheels from driving into the ditch or up onto the verge.

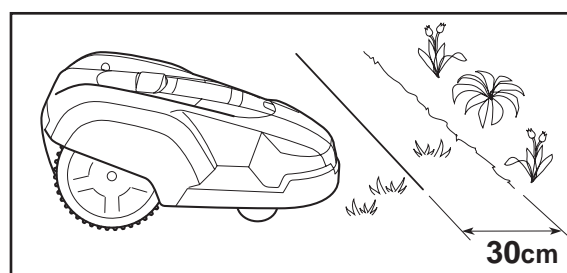

If the working area borders against a flat path or the like that lies level with the lawn, it is possible to allow Automower® to run a little over the path. The boundary wire should then be laid 10 cm from the edge of the path.

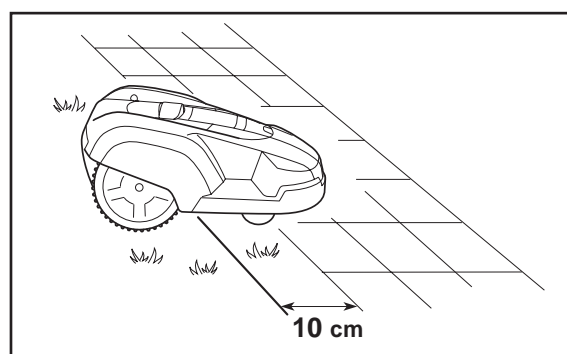

When the working area is divided by a flat slab path that is level with the lawn, it is possible to allow Automower® to run over the path. It can be an advantage to lay the boundary wire under the slabs. The boundary wire can also be laid in the joint between the slabs.

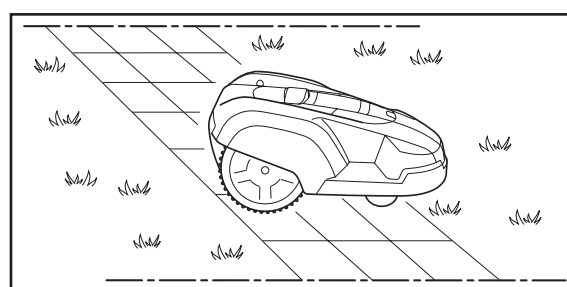

Note! Automower® must never run over a gravel path or similar material, which can damage the blades.

IMPORTANT INFORMATION

If the working area is adjacent to water bodies, slopes or precipices, the boundary wire should be supplemented with a fence or the like. The height must then be at least 15 cm. This will prevent the Automower® from ending up outside the working area under any circumstances.

3. INSTALLATION

Boundaries within the working area

Use the boundary wire to demarcate areas inside the working area by creating islands around obstacles that can not withstand a collision, for example, flower beds and fountains. Run the cable out to the area, route it around the area to be demarcated and then back along the same route. If staples are used, the wire should be laid under the same staple on the return route. When the boundary wire to and from the island are close together, the mower can drive over the wire.

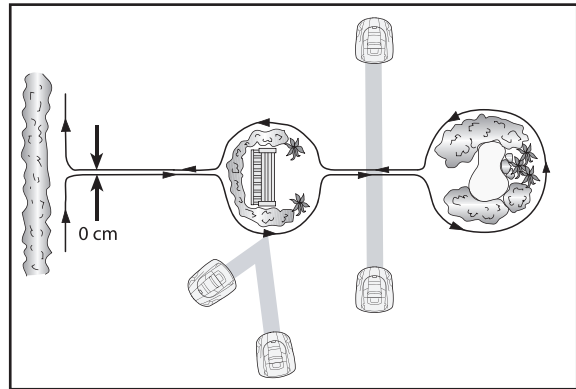

Obstacles that can withstand a collision, for example, trees or bushes higher than 15 cm, do not need to be demarcated by the boundary wire. Automower® will turn when it collides with this type of obstacle.

However, for the most gentle and silent operation, it is preferable to demarcate all fixed objects in and around the working area.

Obstacles that slope slightly, for example, stones or large trees with raised roots, should be demarcated or removed. Automower® can otherwise slide up onto this kind of obstacle causing the blades to be damaged.

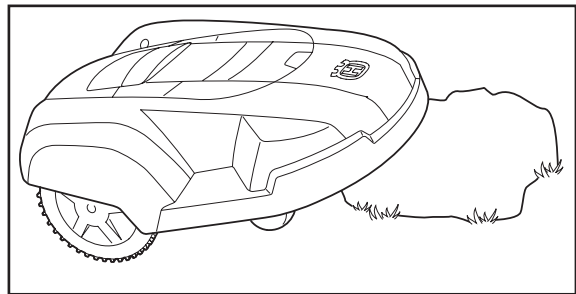

If the mowing result in the garden is uneven due to the shape of the garden, for example because of a long passage, you have the option of dividing up your garden into zones. This is done with the help of the boundary wire, see the figure on the right. When the mower is placed in zone 1, it will not mow in zone 2 and vice versa. Move the mower between the zones to maintain an even mowing results. Also see 6. *Garden example* - proposed installation and settings page 34.

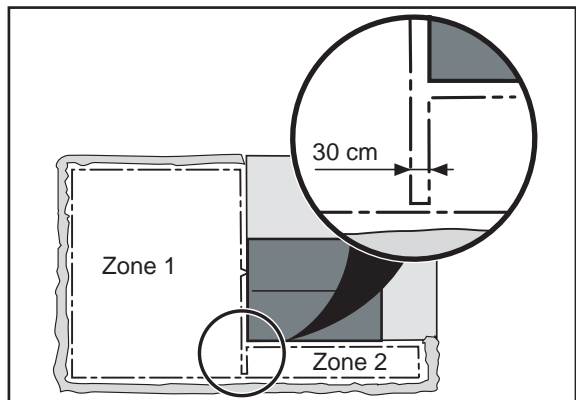

3. INSTALLATION

Secondary areas

It is recommended to create a secondary area when the working area is made up of two areas that are joined by a passage where the distance between the boundary wires is less than 60 cm. Run the boundary wire then around the secondary area so that it forms an island outside of the main area.

Automower® must be moved manually between the main and secondary areas.

Instead of forming an island with the boundary wire, it can be beneficial to use an extra loop generator/charger together with an extra boundary wire. A loop generator/charger can be purchased as an accessory. Contact your dealer for further information.

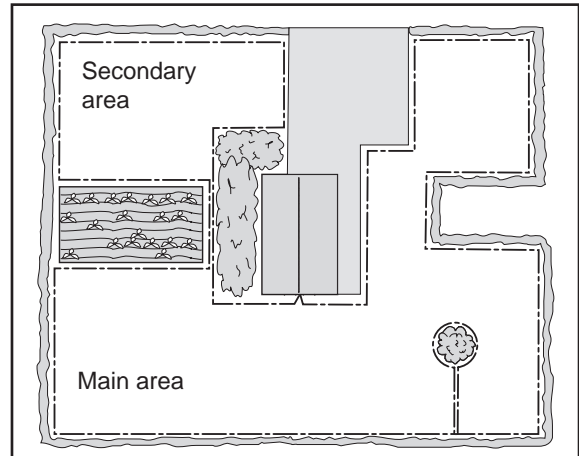

Slopes

The boundary wire can be laid across a slope that slants less than 10 %.

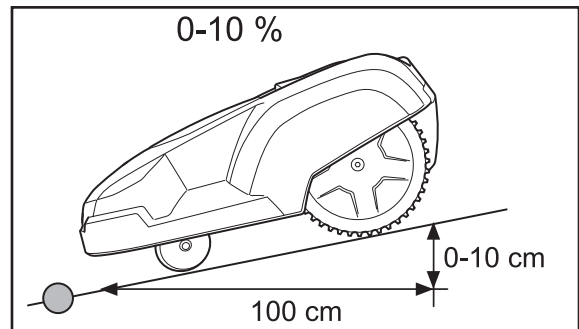

The boundary wire should not be laid across a slope that is steeper than 10 %. There is a risk of Automower® finding it difficult to turn, and being unable to move. The risk is at its greatest in damp weather conditions, as the wheels can slip on the wet grass.

However, the boundary wire can be laid across a slope steeper than 10 % when there is an obstacle that Automower® can be permitted to collide with, for example, a fence or a dense hedge.

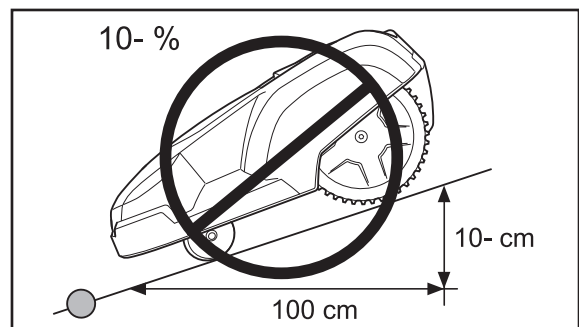

3. INSTALLATION

Automower® can mow areas inside the working area that slope up to 35 cm per distance metre (35 %). Areas that slope more must be demarcated by the boundary wire.

When any part of the working area's boundary slopes more than 10 cm per distance metre (10 %), the boundary wire must be routed about 35 cm in on flat ground before the slope starts.

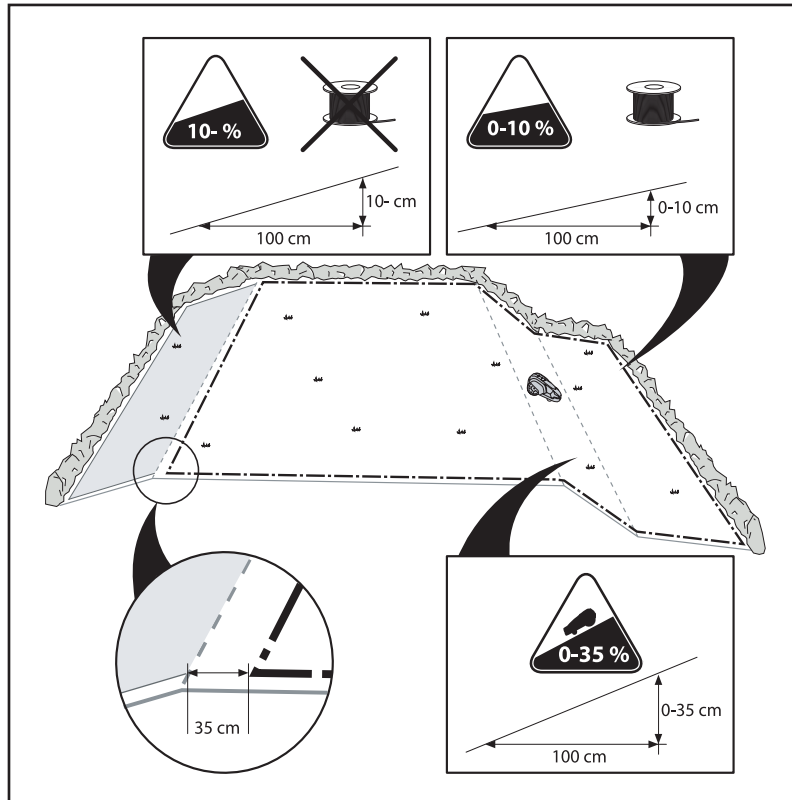

Laying out the boundary wire

Run the boundary wire around the working area, but wait before connecting the wire to the loop generator/charger.

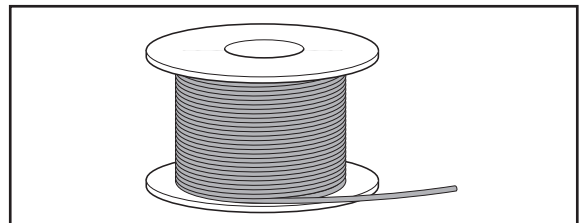

IMPORTANT INFORMATION

Extra wire must not be placed in coils outside the boundary wire. This can disrupt Automower®.

Tip! Use the supplied measurement gauge as a guide when you lay out the boundary wire. This helps you to easily set the correct distance between the boundary wire and the boundary/obstacle.

If you intend to staple down the boundary wire:

- Tip! Mow the lawn where the wire is to be laid using a normal lawn mower or a trimmer. It will then be easier to lay the wire close to the ground and the risk of the mower cutting the wire off is reduced.

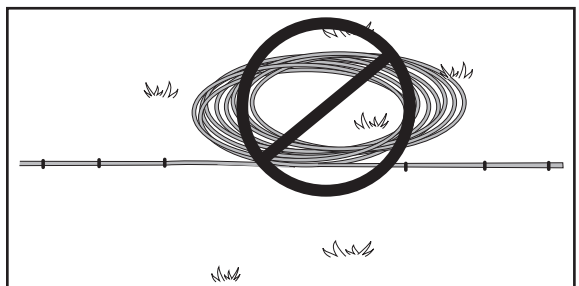

3. INSTALLATION

- Make sure to lay the boundary wire tight to the ground and secure the staples close together with approximately 75 cm between each staple. The wire must generally lie close to the ground so, as not to be cut off before the grass roots have grown over it.
- Use a hammer to knock down the staples in the ground. Exercise care when knocking in the staples and make sure the wire is not under strain. Avoid forming the wire in sharp bends.

If you intend to bury the boundary wire:

- Make sure to place the boundary wire at least 1 cm and a maximum of 20 cm into the ground.

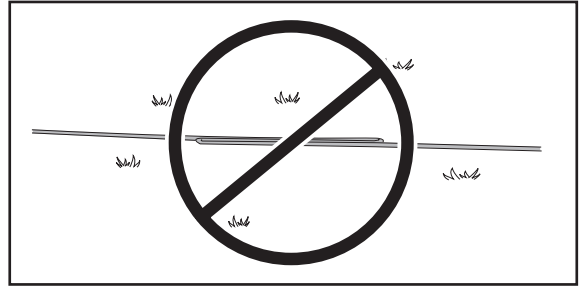

The boundary wire must be crossed on the path to and from an island.

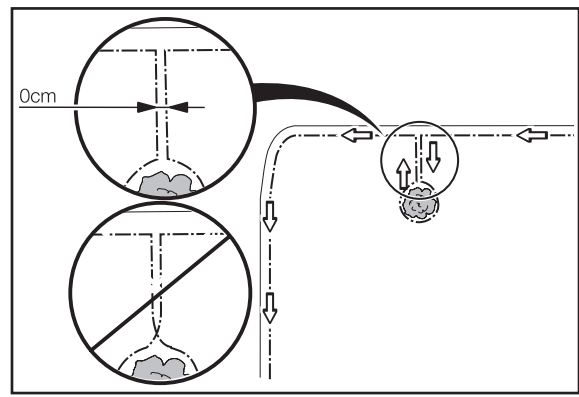

Laying the boundary wire in towards the loop generator/charger

The ends of the boundary wire are run in parallel and close to each other in towards the loop generator/charger. As long as the total length of the boundary wire does not exceed 350 m, the sections where the wires run in parallel can be any length. For example, it is possible to place the loop generator/charger inside the house and run the boundary wire through a window and out to the garden.

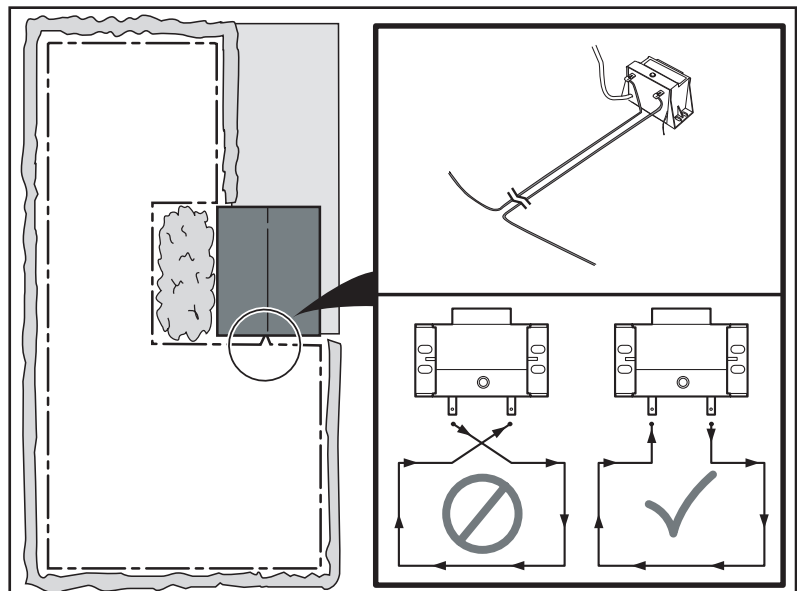

IMPORTANT INFORMATION

Pay particular attention not to cross the boundary wire in towards the loop generator/charger.

3. INSTALLATION

Joining the boundary wire

If the boundary wire is not long enough and needs to be spliced: Use original solderless coupler. It is waterproof and gives a reliable electrical connection.

To splice: Insert both cable ends in the coupler. Now press down the button on top of the connector fully. Use a pair of pliers or the like, as the button on the connector is difficult to press down by hand.

IMPORTANT INFORMATION

Twisted cables, or a screw terminal (chock-block), insulated with insulation tape is not a satisfactory splice. Soil moisture will cause the conductors to oxidise and after a while result in a broken circuit.

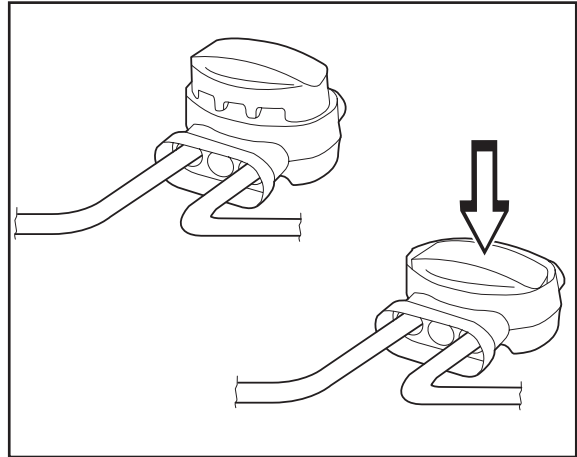

3.5 Connecting the boundary wire

Connect the boundary wire to the loop generator/charger:

1. Place the cable ends in the connector:
 - Open the connector.
 - Place the wire in the connector grip.

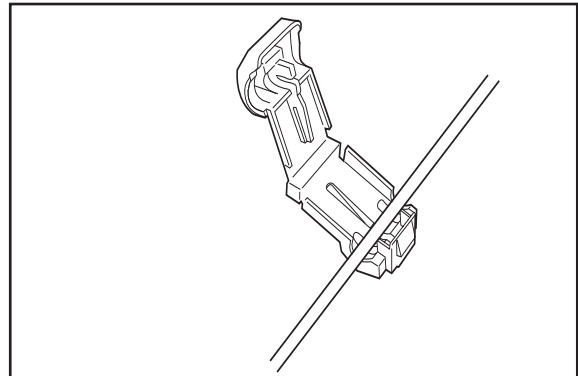

2. Press the connector together using a pair of pliers. Press until you hear a click.

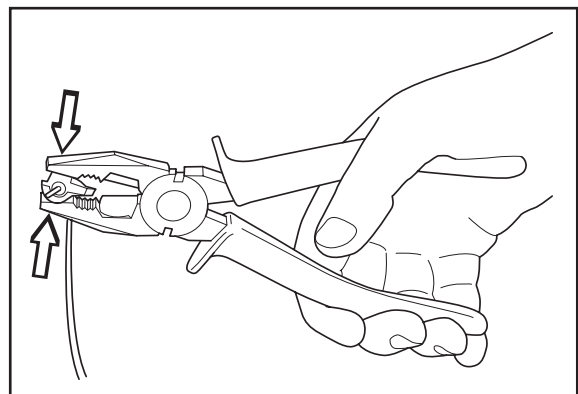

3. INSTALLATION

3. Cut off any surplus boundary wire. Cut 1 - 2 cm above respective connectors.

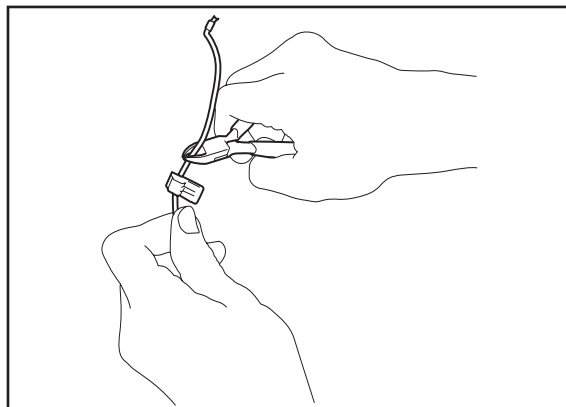

4. Attach the connector to the contact pin on the loop generator/charger.

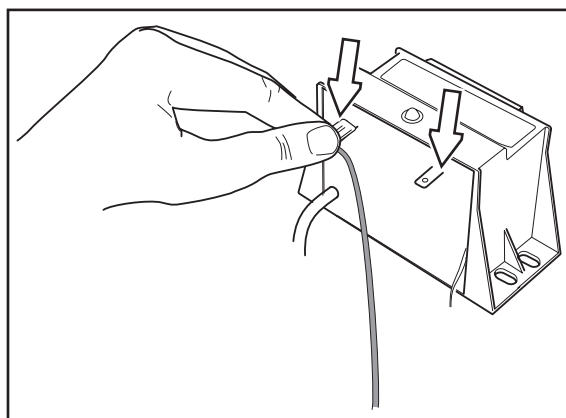

3.6 Checking the installation

Check the loop signal by looking to see what indication the green LED on the loop generator/charger is giving.

- Steady light = the signal is okay.
- Flashing once every other second = break in the loop and no signal found.
- Flashing twice every other second = weak signal. This may be due to the boundary wire exceeding 350 metres or that the cable is damaged. If the mower works, it is not a problem.

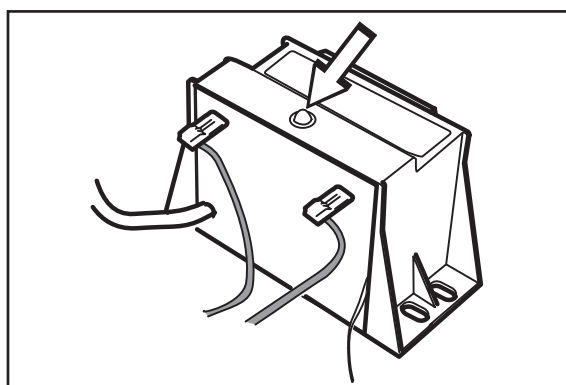

3. INSTALLATION

3.7 Linking Automower® to the loop generator/charger

1. Connect the loop generator/charger charging cable to the mower's charger contact. At most the mower may be two metres from the working area's boundary wire and the loop generator/charger must be connected to the mains supply.
2. Open the control panel cover by pressing the **STOP** button. Set the main switch to the ON position.

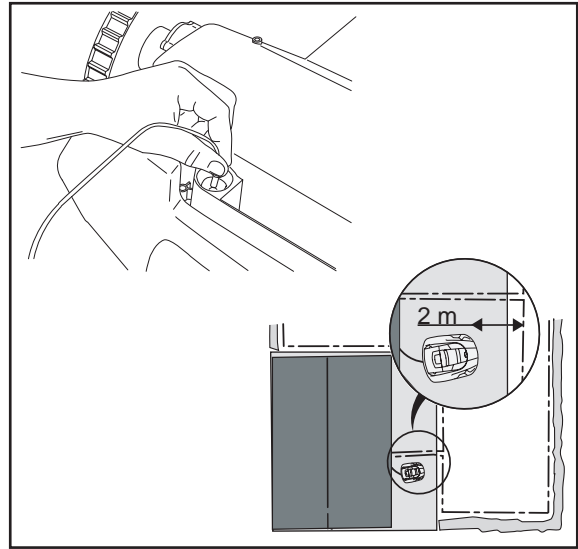

3. The yellow indicator lamp **PIN code** should now flash.
4. Select and enter a four digit PIN code. All combinations except 0000 are permitted.
5. Press the **YES** button.
6. Confirm the selected PIN code by re-entering the PIN code.
7. Press the **YES** button.
8. The yellow indicator lamp **PIN code** flashes once, and then remains unlit.

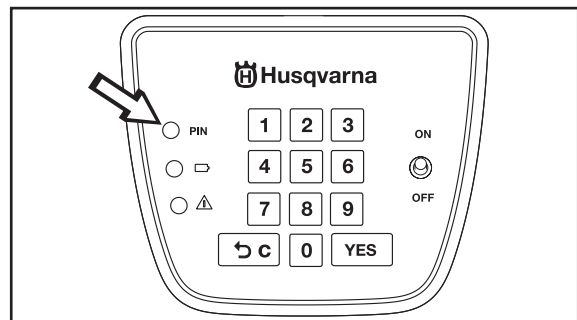

When you have selected a PIN code, the mower and loop generator/charger are linked to each other and the mower can be operated.

4. USE

4. Use

4.1 Starting Automower®



WARNING

Read the safety instructions before you start your Automower®.



WARNING

Keep your hands and feet away from the rotating blades.
Never put your hands or feet close to or under the body when the motor is running.



1. Press the **STOP** button to open the control panel cover on Husqvarna Automower®.
 2. Set the main switch to the *ON* position.
 3. Enter the PIN code, confirm with the **YES** button.
 4. Close the cover.
- 5 beeps are heard over 2 seconds when the blade disc starts.

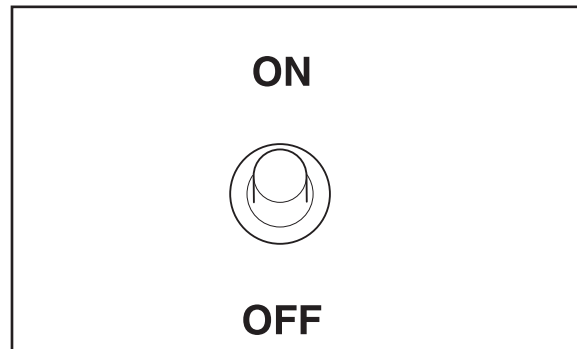

4.2 Stopping Automower®

1. Press the **STOP** button.
Automower® stops, the blade motor stops and the control panel cover opens.

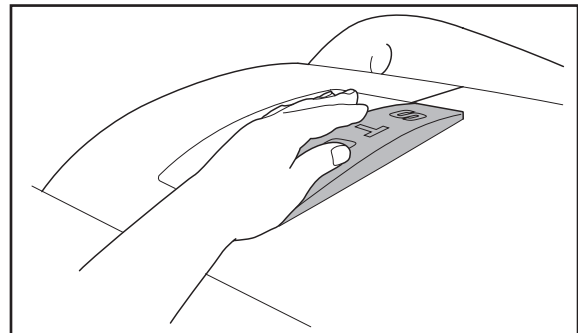

4. USE

4.3 Restart

To start:

1. Enter the PIN code.
2. Press the **YES** button.
3. Close the control panel cover.



4.4 Switching off Automower®

1. Press the **STOP** button.
2. Set the main switch to the *OFF* position.

Always switch off Automower® using the main switch if you intend to perform maintenance or move the mower outside of the working area.

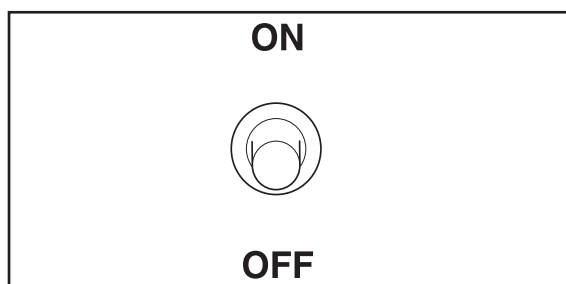

4.5 Using the Timer

The lawn should not be mown for too long to obtain the best result. Use the timer function to avoid flattening the lawn and to get the maximum service life for your Automower®.

The timer function allows the user to select whether the mower is to mow for 1, 2, 3 or the maximum number of hours. The timer is especially useful for mowing small areas, because it will not then be necessary for the Automower® to use its full capacity.

To set the Timer:

1. Enter the PIN code, and confirm with the YES button.
2. Press and hold the number 1, 2 or 3 for two seconds, depending on whether you want the Automower® to mow for one, two or three hours.
3. A double beep confirms your selection and the indicator lamp for the PIN code goes off. It stays off until you release the key (number).
4. Close the cover within 20 seconds, otherwise the selected Timer settings will not be stored. The timer is also reset every time the STOP button is pressed

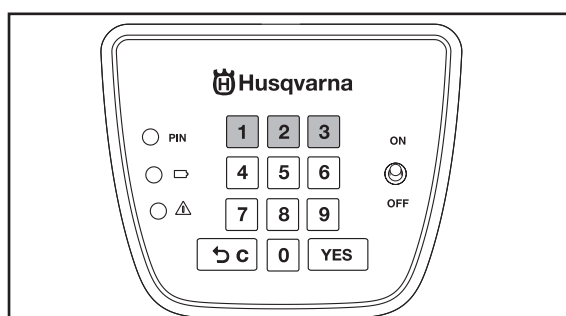

4. USE

4.6 Adjusting the cutting height

The cutting height can be varied from MIN (2 cm) to MAX (6 cm).

If the grass is long it is appropriate to let Automower® start mowing at the MAX cutting height. Once the grass is shorter, you can gradually lower the cutting height.

To adjust the cutting height:

1. Press the **STOP** button to stop the mower.
2. Open the cutting height adjustment cover:
Press down the catch button and then open the cover.

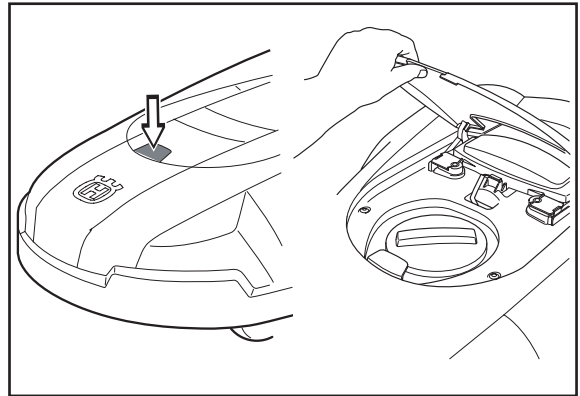

3. Turn the knob to the required position. The selected position is the marking on the knob that aligns with the arrow on the body.
 - Turn clockwise to raise the cutting height.
 - Turn anticlockwise to lower the cutting height.
4. Close the cover. Ensure that the catch button locks.

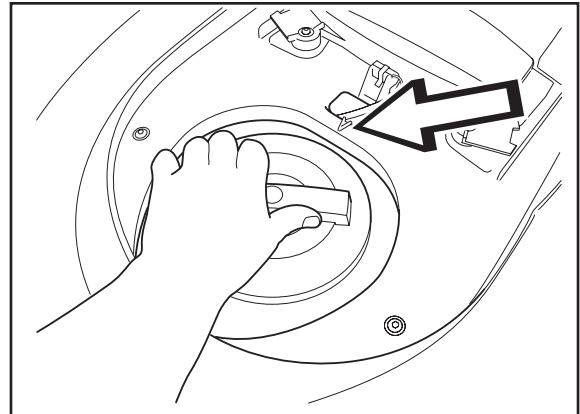

4. USE

4.7 Changing the PIN code

To change the PIN code on the mower:

1. Connect the loop generator/charger charging cable to the mower's charger contact. At most the mower may be two metres from the working area's boundary wire and the loop generator/charger must be connected to the mains supply.
2. Open the control panel cover by pressing the **STOP** button. Set the main switch to the *ON* position.
3. State the current PIN code, confirm by pressing the **YES** button.
4. The yellow indicator lamp **PIN code** should now be lit with a steady light.
5. Press and hold the number **8** key on the control panel for 2 seconds.
6. The yellow indicator lamp **PIN code** should now flash.
7. Select and enter a new four digit PIN code. All combinations except 0000 are permitted.
8. Press the **YES** button.
9. Confirm the selected PIN code by re-entering the PIN code.
10. Press the **YES** button.
11. The yellow indicator lamp **PIN code** should now be lit with a steady light.

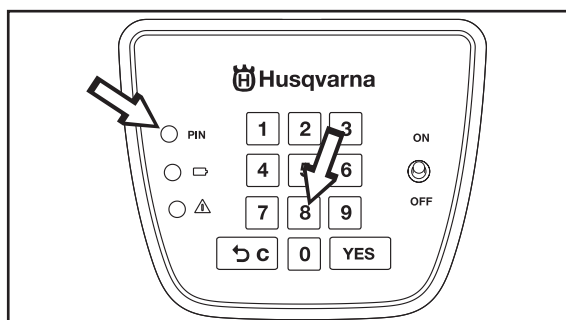
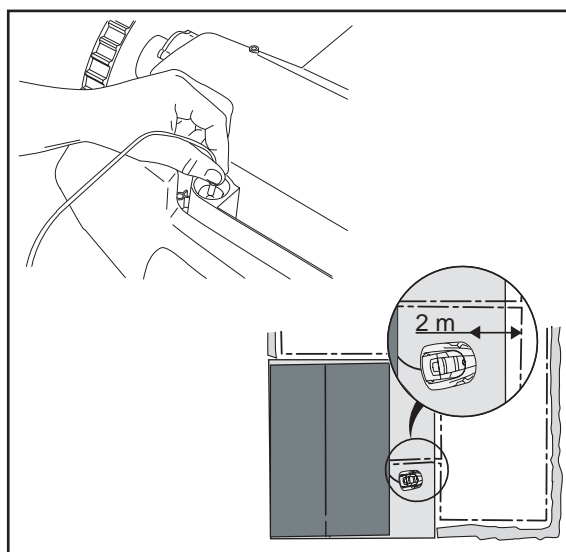

4.8 Charging and storage between mowing

When the Automower® needs charging it stops on the lawn, and the green indicator lamp starts flashing. To charge the mower:

1. Set the main switch to the ON position and leave the cover for the control panel open.
2. Connect the power cord from the loop generator/charger to the charger contact on the mower. The green indicator lamp **Battery** now goes on. When the mower is fully charged the green indicator lamp goes off and the yellow lamp starts flashing.

When the battery is flat it will take 4 - 5 hours before it is fully charged.

To save floor space when storing or charging Automower® between mowing it can be hung up on a wall by using the Automower® wall bracket (504 82 13-01).

4. USE

4.9 Sounds

The mower indicates the operating status and all input with audio signals as set out below.

Sound	Significance
5 beeps over 2 seconds	Starting blade disc
Short click sound	A button on the keypad has been pressed
One long beep	Blade disc blocked
	Incorrect input
	Charging cancelled
Short double beep	Correct input
	Charging starts

5. CONTROL PANEL

5. Control panel

The control panel on Husqvarna Automower® consists of indicator lamps and a keypad. All information is shown through the indicator lamps and all input is done using the buttons.

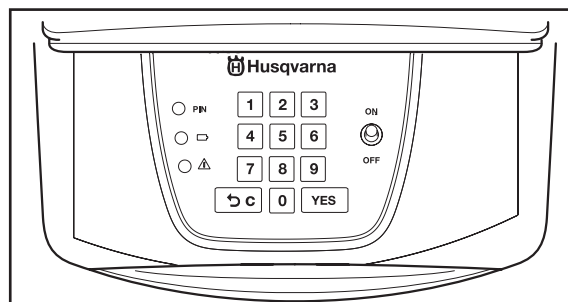

The control panel consists of three groups of buttons: select, numbers and main switch, and indicator lamps..

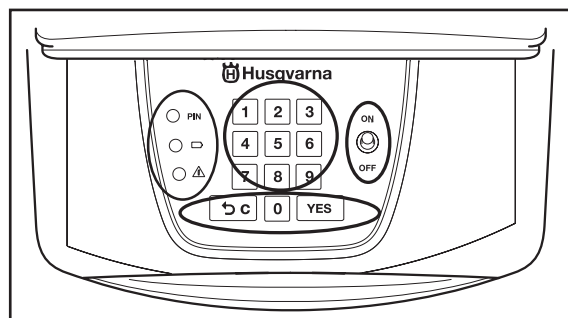

5.1 Select

1. Cancel:
 - Press to interrupt an ongoing input or to reset the mower when a fault message is shown.
2. YES:
 - Press to confirm the entered PIN code.

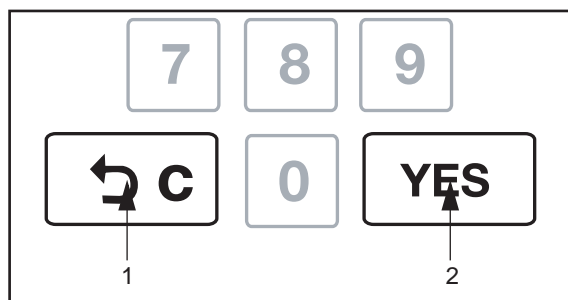

5.2 Numbers

3. Press to state the PIN code.
Also use the special command: See 4.6 *Changing the PIN code* on page 30.

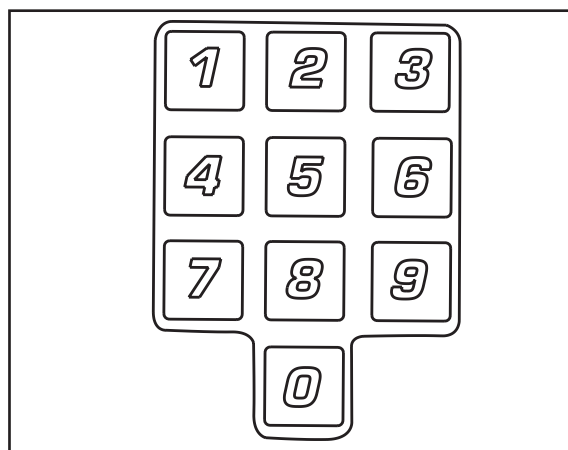

5. CONTROL PANEL

5.3 Main switch

4. Set the main switch in the *ON* position to start Automower®.

Set the main switch in the *OFF* position when you are not using the mower or if you want to work on the blade disc.

When the main switch is set in the *OFF* position the motors on the mower cannot start.

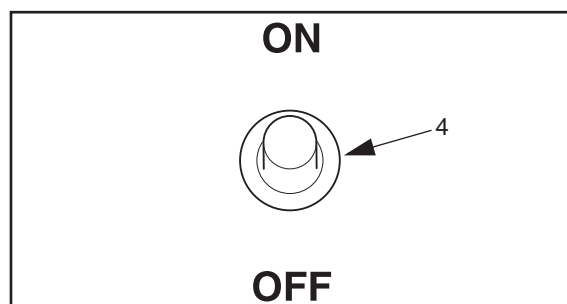

5.4 Indicator lamps

The indicator lamps indicate the status of the mower. If all the lamps are out, the mower is in sleep mode. Start the mower again by switching the main switch off and on.

5. PIN code:

- The lamp is lit with a steady light: The PIN code has been entered and the mower is ready to start. Start the mower by closing the cover.
- The lamp flashes: The PIN code has not been entered. Enter the PIN code using the numerical buttons followed by the **YES** button.

6. Battery:

- The lamp is out: The mower is not charging and it is sufficiently charged to mow.
- The lamp is lit with a steady light: Mower charging.
- The lamp flashes: The mower needs to charge.

7. Fault:

- The lamp is out: No fault.
- The lamp flashes or is lit with a steady light: A fault means the mower can not start, see 8.1 *Fault messages* on page 41.

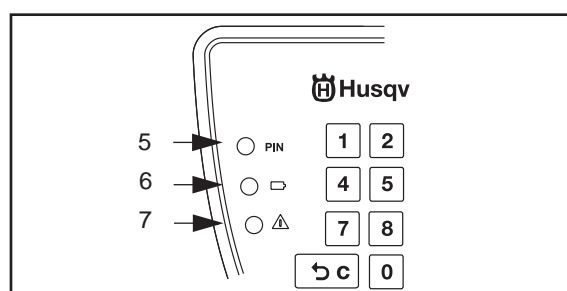

6. GARDEN EXAMPLE

6. Garden example

- Proposed installation

An number of installations of Husqvarna Automower® in different types of gardens are shown and explained in this chapter. See the examples as pointers for how to make the installation in your garden as good as possible. Also see 3. *Installation* on page 15.

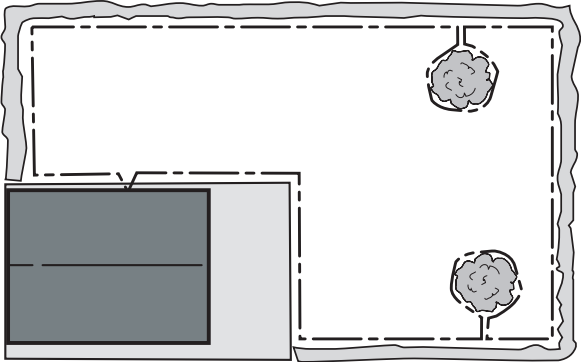
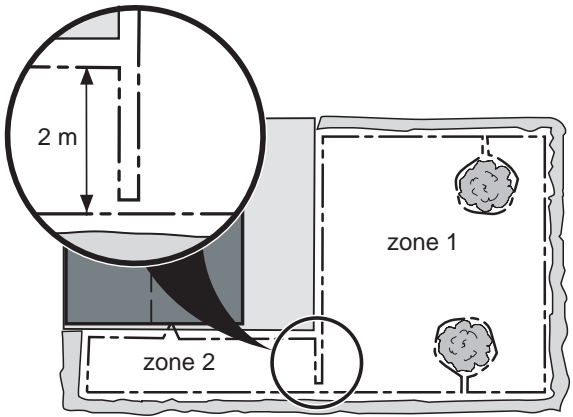
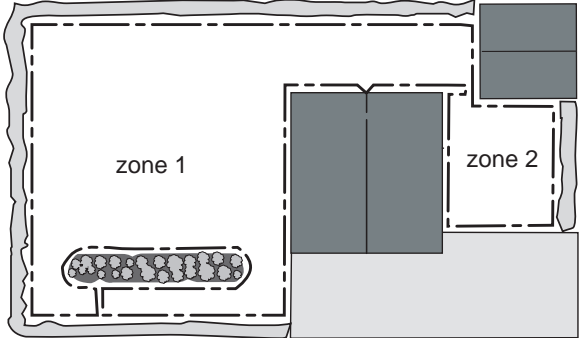
Proposals for installation	
<p>Open garden with narrow passages and obstacles, area: 300 m². The boundary wire has been routed around delicate bushes and the outer edges of the garden.</p>	 <p>The diagram shows a rectangular garden with a dashed boundary wire. A dark grey rectangular area represents the Husqvarna Automower. The boundary wire is routed around two bushes and the outer edges of the garden.</p>
<p>Garden with a long, narrow area, area: 300 m². If the narrow area is not mown often enough, the garden can ideally be divided into two zones. This is done with the boundary wire. Mow zone 1 and zone 2 alternately. If the lawn in zone 2 is smaller than 100 m², the mower should not be left there for the whole of its mowing time. The lawn may then appear trampled down. Use the Timer to reduce the mowing time in the area. To set the Timer, see 4.5 <i>Using the Timer</i> on page 29.</p>	 <p>The diagram shows a garden divided into two zones, 'zone 1' and 'zone 2', by a boundary wire. A narrow passage between the zones is highlighted with a circular inset showing a 2m width. A Husqvarna Automower is shown in zone 2. Two bushes are present in zone 1.</p>
<p>Garden with a narrow passage that divides the garden into two areas, area: 500 m². If the small area is not mown often enough, the garden can ideally be divided into two zones. If the lawn in zone 2 is smaller than 100 m², the mower should not be left there for the whole of its mowing time. Use the Timer to reduce the mowing time in the area. To set the Timer, see 4.5 <i>Using the Timer</i> on page 29.</p>	 <p>The diagram shows a garden divided into two zones, 'zone 1' and 'zone 2', by a boundary wire. A narrow passage separates the zones. A Husqvarna Automower is shown in zone 1. A bush is present in zone 2.</p>

6. GARDEN EXAMPLE

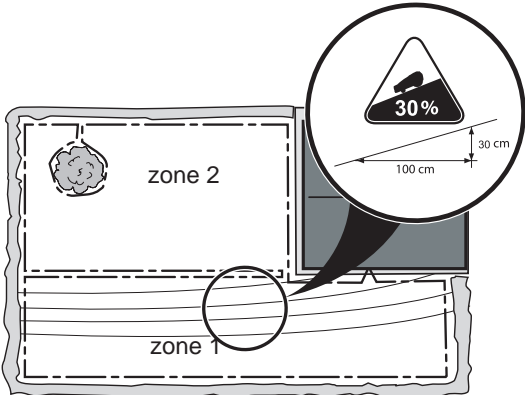
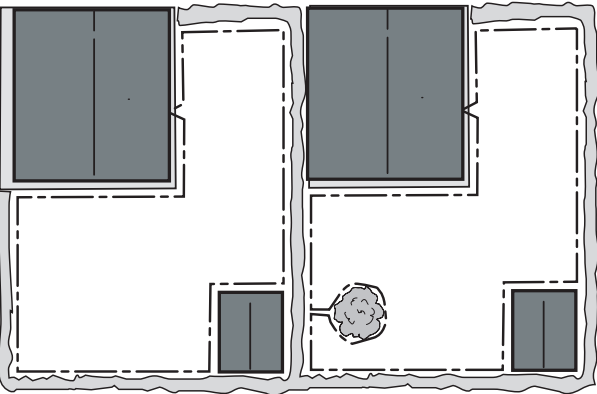
Proposals for installation	
<p>Garden with a steep incline (30 %) that divides the garden into two areas, area: 400 m². If the mowing result between the areas is uneven, the garden can ideally be divided into two zones. The mower may find it difficult to climb steep inclines, consequently a garden with steep inclines can be mown unevenly, even if there are no passages.</p>	 <p>The diagram shows a rectangular garden divided into two zones by a diagonal line representing a 30% incline. The upper zone is labeled 'zone 2' and contains a tree icon. The lower zone is labeled 'zone 1' and contains a circular area with a dashed border. A circular callout on the right shows a right-angled triangle with a 30% slope, a horizontal base of 100 cm, and a vertical height of 30 cm. A dashed line indicates the boundary between the two zones.</p>
<p>Two gardens with the area 200 m². Two separate installations each with a loop generator/charger have been made, where the mower may be moved between gardens.</p>	 <p>The diagram shows two separate garden installations side-by-side. Each installation consists of a rectangular area with a dashed border and a dark grey rectangular area representing a loop generator/charger. A tree icon is located in the central area between the two installations.</p>

7. MAINTENANCE

7. Maintenance

Check and clean Husqvarna Automower® regularly and replace worn parts if necessary to improve operating reliability and to ensure a longer service life. For further information on cleaning, see *7.4 Cleaning* on page 39.

During the initial period Automower® is used the blade disc, skid plate and blades should be checked once a week. If the amount of wear during this period has been low, the inspection interval can be increased.

It is important that the blade disc rotates easily. In addition the skid plate should rotate easily in relation to the blade disc. The edges of the blades should not be damaged. The service life of the blades depends on:

- Operating time and size of the working area.
- Type of grass.
- Type of soil.
- The presence of objects such as cones, windfalls, toys, tools, stones, roots and the like.

The life span can vary greatly, but is normally 150 - 200 hours of operation. To replace the blades, see *7.5 Replacing the blades* on page 41.

IMPORTANT INFORMATION

Working with dull blades gives a poorer mowing result. The edges of the grass are not cut clean and more energy is needed resulting in Automower® not mowing such a large area.

7.1 Battery

The battery is maintenance-free, but has a limited life span of 1-4 years.

Battery life is dependent on the length of the season and how many hours per week Automower® is used. A long season or many hours of use per week, means that the battery must be replaced more regularly.

IMPORTANT INFORMATION

Charge the battery fully at the end of the season before winter storage.

7. MAINTENANCE

7.2 Winter storage

Automower®

Automower® must be carefully cleaned before winter storage, see *7.4 Cleaning* on page 39.

Automower® should not be continuously charged during the winter. Charge the battery fully before winter storage. Turn the main switch to the *OFF* position.

It is also recommended to fully charge the battery sometime during the winter. This will prolong the battery life. The mower should then be charged for about 24 hours. Charge the battery as per the previous instructions, see *3.3 Charging the battery* on page 18.

Store the mower standing on all four wheels in a dry and frost-free area, preferably in its original packaging, or alternatively suspended from a wall with the Automower® wall bracket (504 82 13-01).

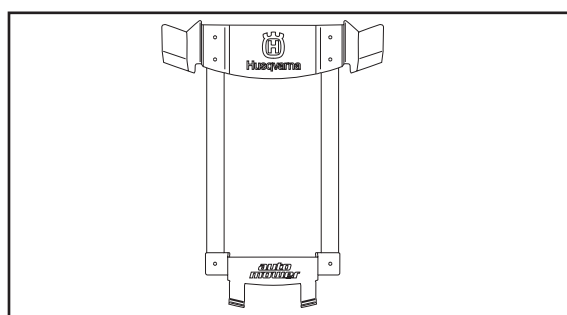
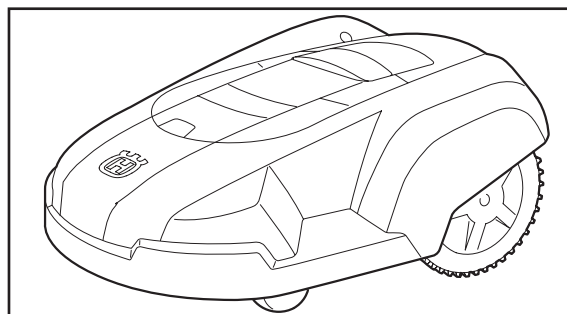

Loop generator/charger

If possible store the loop generator/charger indoors. The boundary wire can be left in the ground. If the loop generator/charger is taken in you should protect the ends of the boundary wire from moisture by placing them, for example, in a tin with grease. If indoor storage is not possible, the boundary wire should remain connected and the loop generator/charger should remain connected to the mains supply.

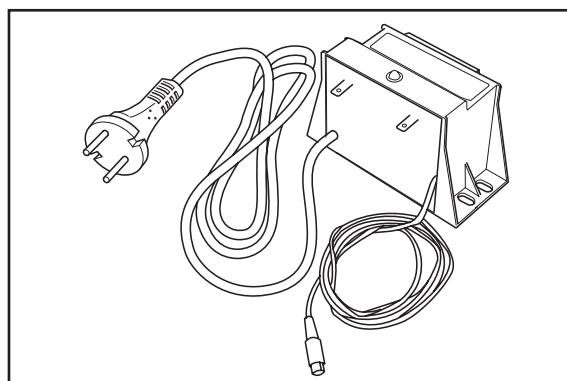

7.3 Service

Leave your Automower® to a dealer for service prior to winter storage. This is essential in order to keep the mower in a good condition.

Service usually includes the following:

- Thorough cleaning of body, chassis, blade disc, skid plate and all other moving parts.
- Testing of the mower's function and components.
- Checking of wear components such as mower blades and bearings.
- Testing of the mower's battery capacity as well as a recommendation of change if necessary.
- Relubrication of both chassis halves of the mower in order to maintain moisture and wetness resistance.
- If necessary the dealer can also load the Automower® with new software, possibly including newly added features.

7. MAINTENANCE

7.4 Cleaning

It is important to keep Automower® clean. A mower with a large amount of clippings negotiates slopes very poorly. It is recommended to clean using a brush and a spray with water.

IMPORTANT INFORMATION

Never use a high-pressure washer or even running water to clean the Automower®. Solvent must never be used when cleaning.

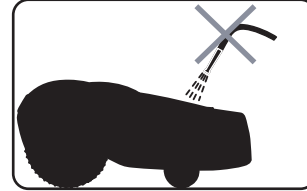

Underframe and blade disc

1. Set the main switch to the *OFF* position.
2. Wear protective gloves.

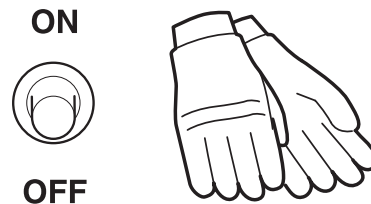

3. Lift Automower® onto its side.
4. Clean the blade disc and underframe using, e.g. a dish-brush.

At the same time, check that the blade disc rotates freely in relation to the motor support, directly above. Check also that the skid plate rotates freely in relation to the blade disc.

If long blades of grass or other objects work their way in this can brake the blade disc and/or skid plate. Even a slight braking effect leads to a higher consumption of energy and longer mowing times, and at the worst will prevent the mower from being able to mow a large lawn. If more thorough cleaning is necessary the skid plate, and possibly the blade disc, must be dismantled. If necessary, contact your dealer.

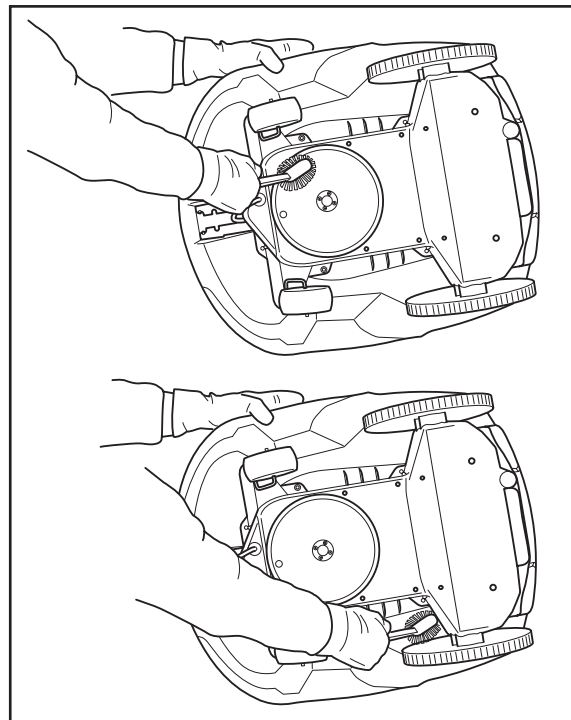

Chassis

Clean the underside of the chassis. Brush or wipe with a damp cloth.

Wheels

Clean around the front and rear wheels and around the front wheel suspension.

7. MAINTENANCE

Body

Use a damp, soft sponge or cloth to clean the body. If the body is very dirty it may be necessary to use a soap solution or washing-up liquid.

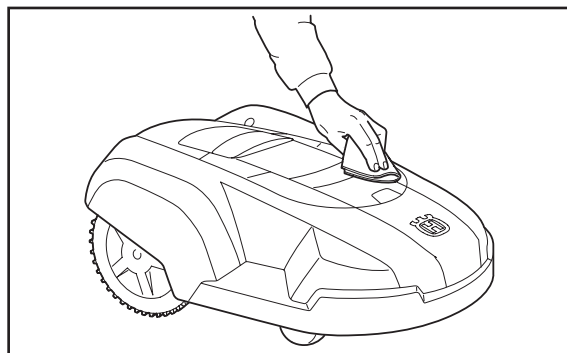

7.5 Replacing the blades



WARNING

Always use original blades and screws when replacing. Only replacing the blades and reusing the screw can result in the screw wearing during mowing and shearing off. The blades can then be thrown out and cause serious injury.

There are three blades on Automower®, which are screwed into the blade disc. The blades have two edges to ensure a longer service life. The blade disc rotates alternately to the left and alternately to the right.

All three blades and screws must be replaced at the same time to obtain a balanced mowing system.

There are two blade variants with different characteristics to choose from as accessories. Contact your dealer for further information.

There are several different types of mower blades to choose from as accessories, with different features. Use Husqvarna AB approved blades only, see the table. Please contact your dealer for more information.

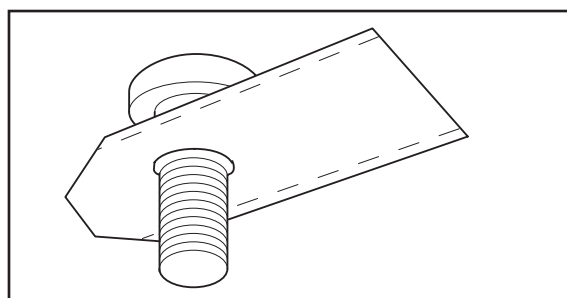

Blade type	Quantity/Packaging	Part number
<i>Stainless steel</i> <i>(two-toothed, stainless)</i>	9	535 13 87-01
	30	535 13 88-01
	500	505 12 78-01

7. MAINTENANCE

Blade type	Quantity/Packaging	Part number
<i>Carbon steel (two-toothed)</i>	9	535 13 87-02
	30	535 13 88-02
	500	535 12 78-02
<i>Carbon steel (two-toothed, turnable, extra robust)</i>	9	522 85 16-02
	30	522 85 17-02
	300	522 85 18-02

To replace the blades:

1. Set the main switch to the *OFF* position.
2. Wear protective gloves.
3. Turn Automower® upside down.
4. Rotate the skid plate so that its hole aligns with the screw for the blade.
5. Unscrew the blade. Use a straight slot or cross-tip screwdriver.
6. Pry apart the skid plate and blade disc a little and remove the blade and screw.
7. Screw tight the new blade.

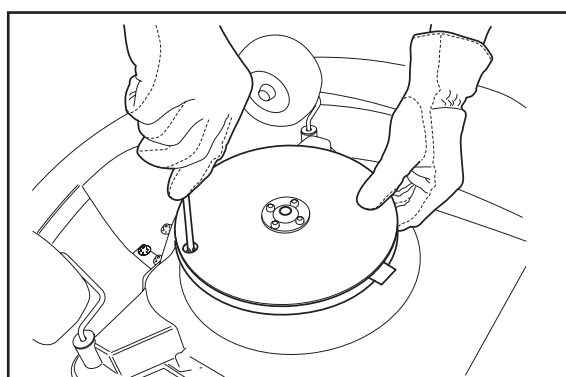
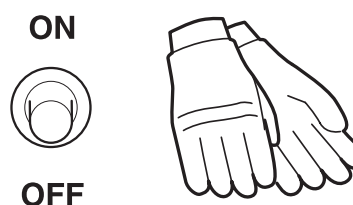

7.6 Transport and moving

Secure the machine during transport. It is important that the Automower® does not move around while being transported e.g. between different grass areas. There is an Automower® bag (522 91 67-01) designed especially to facilitate transport. Please contact your dealer for more information.

8. TROUBLE SHOOTING

8. Trouble shooting

8.1 Fault messages

A number of fault messages that can be shown by the red **Fault** indicator lamp on Husqvarna Automower® are shown below. The fault message is interpreted by reading how the lamp flashes. The lamp flashes one to five times in quick succession and then goes out for 2 seconds. This sequence is repeated until the **Cancel** button is pressed. For example, three flashes in the table below corresponds to the lamp flashing three times in quick succession, and then going out.

Always try to restart the mower if the **Fault** indicator lamp is lit or flashes. Restart the mower by pressing the **Cancel** button, enter your PIN code and close the cover

If the same fault occurs frequently, or if the **Fault** indicator lamp is lit with a steady light: contact your dealer.

Flashes	Fault message	Cause	Action
1	<i>Wrong PIN code</i>	Wrong PIN code has been entered. Three attempts are permitted, the keypad is then blocked for five minutes.	Enter the correct PIN code.
1	<i>Charger cable not connected</i>	The charger cable is not connected when changing the PIN code, or when connecting the mower to the loop generator/charger.	Connect the charger cable
2	<i>No loop signal</i>	The loop generator/charger is not connected to the mains supply or its miniature circuit-breaker has tripped.	Check the wall socket connection and whether the miniature circuit-breaker has tripped. Reset the miniature circuit-breaker by removing the loop generator/charger's power cord from the wall socket, wait 10 seconds and then reconnect the power cord in the wall socket again.
		Boundary wire broken.	Check the signal given by the LED on the loop generator/charger. If it flashes the loop is damaged. Repair the broken cable using an original waterproof coupler.
		The connection between Automower® and the charging station has been lost.	Link the mower to the loop generator/charger by changing the PIN code, see page 30. You can use the same PIN code as earlier. You can use the same PIN code as earlier.
		This may be due to the boundary wire being routed in the wrong direction around an "island", which blanks out the signal.	Check that the boundary wire has been routed correctly.

8. TROUBLE SHOOTING

Flashes	Fault message	Cause	Action
2	<i>No loop signal</i>	If this occurs in isolated areas it may be due to interference from metallic objects (perimeter fence, reinforcement bar) or buried cables in the vicinity.	Try moving the boundary wire.
3	<i>No drive</i>	Automower® has got caught in something.	Free the mower and rectify the reason for the lack of drive. If it is due to wet grass, wait until the lawn has dried before using the mower. To keep the drive wheels clean and thus increase traction, use Automower® wheel brushes (505 13 27-01).
3	<i>Upside down</i>	Automower® leans too much or has turned over.	Turn the mower the right way up.
3	<i>Trapped</i>	Automower® has got caught in something.	Free Automower® and rectify the reason for it getting trapped.
4	<i>Outside working area</i>	The boundary wire is crossed when connecting to the loop generator/charger.	Switch the two connections for the loop generator/charger on the boundary wire.
		The gradient for the boundary cable is too steep.	Check that the boundary wire has been routed correctly.
		The boundary wire has been routed the wrong way around an "island".	Check that the boundary wire has been routed in accordance with the installation instructions.
		The boundary wire is too close to the edge of the working area.	Check that the boundary wire has been routed correctly.
		If this occurs in isolated areas it may be due to interference from metallic objects (perimeter fence, reinforcement bar) or buried cables in the vicinity.	Try moving the boundary wire.
5	<i>Wheel motor blocked</i>	Grass or other object has wrapped around the drive wheel.	Check the drive wheel and remove the grass or other object.
5	<i>Blade disc blocked</i>	Grass or other object has wrapped around the blade disc.	Check the blade disc and remove the grass or other object.

8. TROUBLE SHOOTING

8.2 Fault symptom

If your Automower® does not work correctly, follow the trouble shooting guide below. If the fault persists; contact your dealer.

Symptom	Cause	Action
Uneven mowing results	Automower® works too few hours per week.	Increase the mowing time.
	Working area too large.	Try limiting the working area or extending the mowing time.
	Dull blades.	Replace all the blades and screws so that the rotating parts are balanced.
	Long grass in relation to the set cutting height.	Increase the cutting height and then successively lower.
	Accumulation of grass by the blade disc or around the motor shaft.	Check that the skid plate and blade disc rotate easily. If not, the skid plate and perhaps the blade disc must be removed and the grass and foreign objects removed. See <i>7.4 Cleaning</i> on page 39.
Automower® vibrates	Unbalanced blade disc or damaged blades.	Inspect the blades and screws and replace them if necessary.
The mower mows for shorter periods than usual	Grass or a foreign object is blocking the blade disc or skid plate.	Dismantle and clean the skid plate and blade disc.
	This behaviour is normal in high temperatures (gradually increasing above 25°C).	No action.
	The battery is spent.	Contact your dealer to check and replace the battery.

9. TECHNICAL DATA

9. Technical data

Data	Automower® 210 C
Dimensions	
Length	76 cm
Width	55 cm
Height	30 cm
Weight	9.1 kg
Electrical system	
Battery	NiMH special battery 18V / 3Ah
Transformer	230V / 24V
Power consumption	Maximum 9 kWh/month, mowing three times a week
Noise emissions	
Measured noise level	62 dB(A)
Guaranteed noise level	64 dB(A)
Mowing	
Mowing system	Three, pivoted cutting knife blades
Blade motor speed	2500 rpm
Power consumption during cutting	36 W +/- 20%
Cutting height	2-6 cm
Cutting width	22 cm
Working capacity	500 m ² +/- 20%, depending on the number of mowings per week.

10. ENVIRONMENTAL INFORMATION

10. Environmental information

The symbol on Husqvarna Automower® or its packaging indicates that this product may not be treated as household waste. Instead it shall be handed over to the applicable collection point for the recycling of electrical and It should instead be left at a suitable recycling centre to recycle its electronic components and batteries. Contact your dealer for a disassembly of the batteries.

By ensuring this product is disposed of correctly, you will help prevent potential negative consequences for the environment and human health, which could otherwise be caused by inappropriate waste handling of this product.

For more detailed information about recycling of this product, please contact your local council office, your household waste disposal service or the shop where you purchased the product.

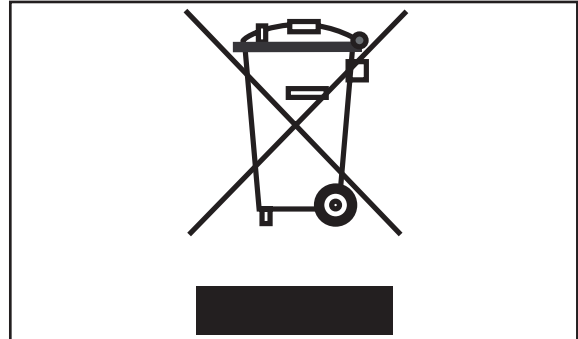

11. EU declaration of conformity

EU Declaration of Conformity (only applies to Europe)

Husqvarna AB, SE-561 82 Huskvarna, Sweden, tel.: +46-36-146500, hereby declares that robotic lawnmower **Husqvarna Automower® 210 C** from 2009's serial numbers and onwards (the year is clearly stated in plain text on the rating plate with subsequent serial number), complies with the requirements of the COUNCIL'S DIRECTIVE:

- Directive "relating to machinery" **2006/42/EC**.
- Directive "relating to electromagnetic compatibility" **2004/108/EC** and applicable supplements. The following standards have been applied: **EN 55014-1 and EN 55014-2**

Huskvarna, October 1, 2009



Christer Gustafsson, Development Manager robotic lawnmowers
(Authorized representative for Husqvarna AB and responsible for technical documentation)

11. EU DECLARATION OF CONFORMITY

Serial number: _____

Personal code: _____

Dealer _____

Dealer's telephone number: _____

ORIGINAL INSTRUCTIONS

AUTOMOWER is a trademark owned by Husqvarna AB. Copyright © 2010 HUSQVARNA. All rights reserved.