

**ILLUSTRATED PARTS BREAKDOWN**

**16 HP 44" GARDEN TRACTOR  
MODEL NO. GT160 (H1644B)  
954 00 01-81**

# REPAIR PARTS

## 16 HP 44" RIDING TRACTOR - - MODEL NUMBER GT160

### ELECTRICAL

#### HARDWARE

- A - 9
- B - 30
- C - 45,46
- D - 35,36,40
- E - 42,48
- F - 22,35

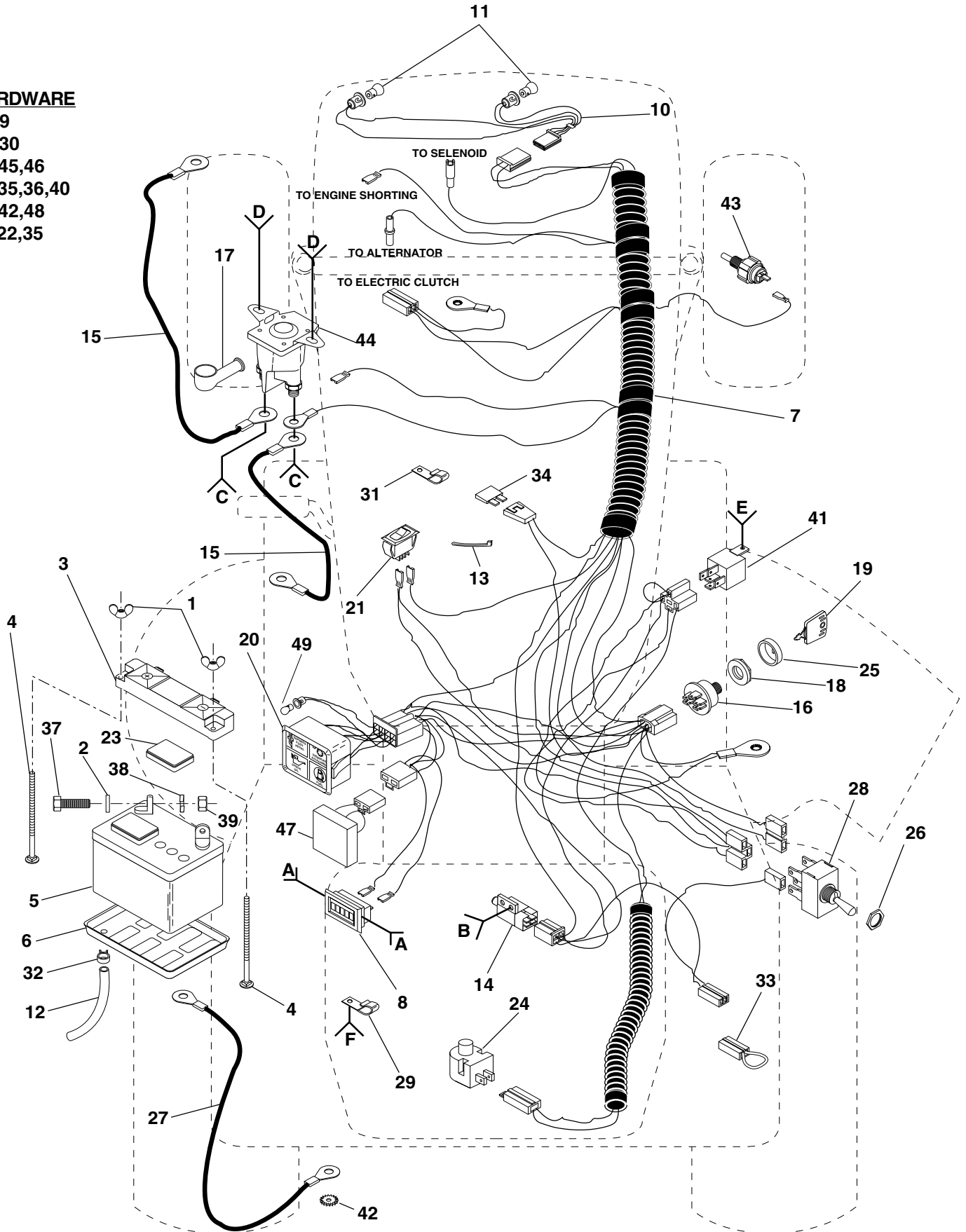

# REPAIR PARTS

## 16 HP 44" RIDING TRACTOR - - MODEL NUMBER GT160

### ELECTRICAL

KEY NO.	PART NO.	DESCRIPTION	KEY NO.	PART NO.	DESCRIPTION
1	532123198	Nut, Wing 1/4-20	30	817021008	Screw, Hex, Tap #10-24 UNC
2	819091016	Washer 9/32 x 5/8 x 16 Gauge	31	532124996	Clip, Fuel Line
3	532102476	Guard, Terminal	32	532109596	Clamp, Hose
4	872240460	Bolt, Carriage 1/4-20 x 7-1/2	33	532102501	Loop, Wire
5	532121537	Battery	34	532108824	Fuse
6	532124886	Tray, Battery	35	874780408	* Bolt, Hex 1/4-20 x 1/2 Grade 5
7	532124384	Harness, Ignition (Includes Key #41)	36	873510400	Nut, Hex, Keps 1/4-20
8	532110940	Meter, Hour	37	874760412	* Bolt, Hex 1/4-20 x 3/4
9	817011008	Screw 10-24 x 1/2	38	810040400	* Washer, Lock 1/4
10	532110859	Harness, Light Socket	39	873220400	* Nut, Hex 1/4-20
11	532124893	Bulb, Light	40	811050400	Washer, Lock, External Tooth 1/4
12	532100541	Tube, Battery Tray	41	532109748	Relay
13	532124756	Tie, Cable	42	811050600	Washer, Lock, External Tooth 3/8
14	532109553	Switch, Interlock (Clutch)	43	532126825	Switch, Oil Sensor
15	532124770	Cable, Battery (2)	44	532109081	Solenoid
16	532102972	Switch, Ignition	45	810090400	Washer, Lock 1/4
17	532124783	Cover, Terminal	46	873350400	* Nut, Hex, Jam 1/4-20
18	532109788	Nut, Ignition	47	532127385	Sensor, Low Voltage
19	532122147	Key, Molded	48	817190408	Screw, Hex Washer Thrd. Cut 1/4-20 x 1/2
20	532109555	Light, Package	49	110143X	Bulb, Light Package
21	532110712	Switch, Light	—	532101539	Sheet, Instruction, Tractor 15° Slope (English)
22	873680400	Nut, Crownlock 1/4-20	—	532101572	Sheet, Instruction, Tractor 15° Slope (French)
23	532121264	Caps, Battery	—	532127303	Manual, Operator's (English)
24	532121305	Switch, Plunger	—	532127304	Manual, Operator's (French)
25	532109787	Bezel, Ignition	—	532121549	Decal, Battery, Caution
26	532124932	Nut, Hex			
27	532124773	Cable, Battery			
28	532126018	Switch, PTO			
29	532124995	Clip, Insulated			

\* STANDARD HARDWARE - PURCHASE LOCALLY

**NOTE:** All component dimensions given in U.S. inches.  
1 inch = 25.4 mm

# REPAIR PARTS

## 16 HP 44" RIDING TRACTOR -- MODEL NUMBER GT160

### CHASSIS ENCLOSURES

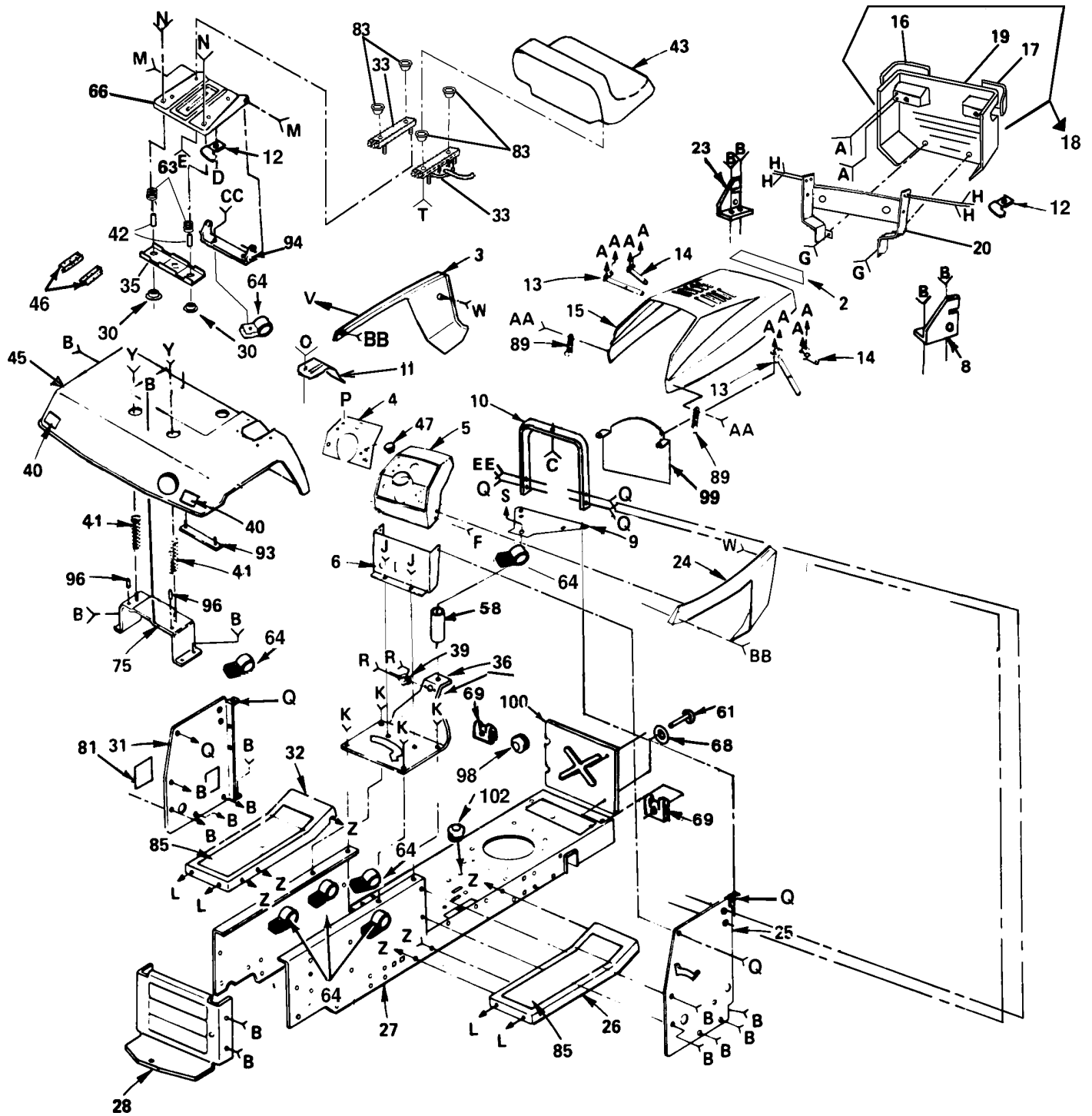

#### HARDWARE

A-49  
 AA-48,86,87,88,101  
 B-57  
 BB-90,91,92,97  
 C-70,80  
 CC-52  
 D-1,104

E-21,34  
 EE-52,53,77  
 F-51,52,53,71  
 G-59,78  
 H-60,62  
 J-34,76  
 K-65

L-50,51,52  
 M-34,95  
 N-22,44  
 O-29,38,54  
 P-67,74,76  
 Q-50,52  
 R-72

S-34,73  
 T-82  
 V-37,79  
 W-7,70  
 Y-52,103  
 Z-52,84

# REPAIR PARTS

## 16 HP 44" RIDING TRACTOR - - MODEL NUMBER GT160

### CHASSIS ENCLOSURES

KEY NO.	PART NO.	DESCRIPTION	KEY NO.	PART NO.	DESCRIPTION
1	874641008	Screw, Slotted Pan Head #10-32 x 1/2	57	817490612	Screw, Hex Washer Hd. Thread Rolling 3/8-16 x 3/4 Type TT
2	532105037	Foam, Strip	58	532121236	Spacer
3	532125009	Panel, Side, L.H.	59	874760440	Bolt, Hex 1/4-20 x 2-1/2
4	532124772	Dash, Plate	60	532123481	Bolt, Shoulder 1/4-20
5	532124182	Dashboard	61	532123650	Stud 1/4 Turn
6	532104805	Dash, Assembly, Lower	62	873680400	Nut, Crownlock 1/4-20
7	532001260	Spacer	63	532123740	Spring, Compression
8	532110853	Bracket, Assembly, R.H.	64	532124996	Clip, Insulated
9	532106965	Plate, Support, Battery	65	817490608	Screw, Hex Washer Hd. Thd. Forming 3/8-16 x 1/2 Type TT
10	532124130	Support, Assembly, Dash	66	532124294	Pan, Seat
11	532123825	Console, Shifter	67	819111116	Washer 11/32 x 11/16 x 16 Gauge
12	532004171	Clip, Insulated	68	532105838	Retainer 1/4 Turn
13	532106784	Strap, Assembly, Hinge, Rear	69	532105839	Receptacle 1/4 Turn
14	532104618	Strap, Assembly, Hinge, Front	70	873220400	Nut, Hex 1/4-20
15	532125007	Hood	71	819091216	Washer 9/32 x 3/4 x 16 Gauge
16	532124250	Lens, L.H.	72	817431008	Screw, Hex Head Self Tapping #10-16 x 1/2 Type B
17	532124251	Lens, R.H.	73	874760532	* Bolt, Hex 5/16-18 x 2 Grade 2
18	532127320	Grill Assembly (Inc. Key #16, 17 & 19)	74	873510500	Nut, Keps 5/16-18
19	532127325	Grill	75	532105509	Bracket Assembly, Fender
20	532124574	Support Assembly, Grill	76	874180512	Screw, Mach 5/16-18 x 3/4
21	819111610	Washer 11/32 x 1 x 10 Ga.	77	811050600	Washer, Lock 3/8 External Tooth
22	532123976	Locknut, Hex, Large Flange 1/4-20 UNC	78	532121235	Spacer
23	532110852	Bracket, Assembly, L.H.	79	873490400	Nut, Wing 1/4-20
24	532125008	Panel, Side, R.H.	80	811050400	Washer, Lock 1/4 Int./External
25	532110828	Panel, Dash, R.H.	81	532121794	Cover, Access
26	532124914	Footrest, R.H.	82	817190516	Screw, Hex 5/16-18 x 1
27	532127166	Chassis	83	532124427	Spacer
28	532123785	Drawbar	84	872140606	* Bolt, Carriage 3/8-16 x 3/4
29	819060718	Washer 3/16 x 7/16 x 18 Gauge	85	532108256	Pad, Footrest
30	532121248	Bushing, Snap	86	874191008	Screw, Cross Recess Pan Hd. Machine #10-24 x 1/2
31	532124118	Panel, Dash, L.H.	87	810071000	* Washer, Lock #10
32	532124899	Footrest, L.H.	88	532125004	Nut, Weld
33	532124428	Slide Set, Seat	89	532109808	Latch, Hood
34	873680500	Locknut 5/16-18	90	874981020	Screw, Machine CR #10-24 x 1-1/4
35	532121246	Bracket, Switch Mount	91	532007206	Spacer, Split #10 x 3/4
36	532124771	Saddle	92	873731000	Nut, Keps #10-24
37	811030400	Washer, Lock 1/4 Int./External	93	532105511	Strap Assembly, Fender
38	810100800	Washer, Lock #8	94	532126656	Bracket, Pivot, Seat
39	532124720	Bushing, Steering	95	532105529	Bolt, Shoulder 5/16-18
40	532106202	Reflector, Taillight	96	532105531	Nut, Push
41	532124181	Spring, Compression	97	819070818	Washer 7/32 x 1/2 x 18 Gauge
42	532121249	Spacer, Split 0.28 x 0.88	98	532110436	Grommet, Split
43	532124187	Seat	99	532126493	Baffle, Rear Upper
44	872170410	Bolt, Carriage 1/4-20 x 1-1/4	100	532108105	Shield, Head
45	532124929	Fender	101	532110357	Washer, Snap Cap
46	532121251	Foam, Strip	102	532124934	Grommet
47	532005479	Plug, Dash	103	819131614	Washer 13/32 x 1 x 14 Gauge
48	532110356	Cap, Snap	104	873951000	Nut, Keps #10-32 UNC
49	873510400	* Nut, Hex 1/4-20	—	532124480	Decal, Hood, L.H.
50	874760612	* Bolt, Hex 3/8-16 x 3/4	—	532124481	Decal, Hood, R.H.
51	819131312	Washer 13/32 x 13/16 x 12 Gauge	—	532124483	Decal, Grill, Logo
52	873680600	Nut, Crownlock 3/8-16	—	532124487	Decal, Side Panel
53	874760616	* Bolt, Hex 3/8-16 x 1	—	532124484	Decal, Fender (Rear)
54	874640806	* Screw #8-3/8	—	532120822	Decal, Fender (Front)
			—	532101892	Decal, Clutch/Brake
			—	532109821	Decal, Operating Instruction (Dash)
			—	532109199	Decal, Belt Instruction (Under Footrest)

\* STANDARD HARDWARE - PURCHASE LOCALLY  
**NOTE:** All component dimensions given in U.S. inches.  
 1 inch = 25.4 mm

# REPAIR PARTS

## 16 HP 44" RIDING TRACTOR -- MODEL NUMBER GT160

### DRIVE GROUP

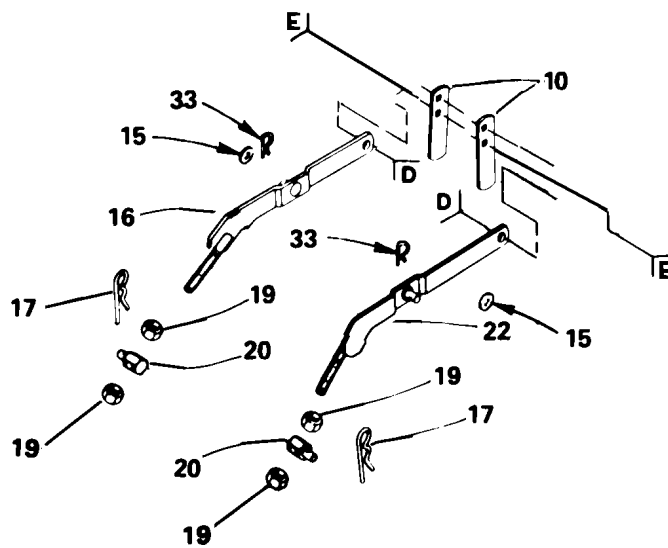
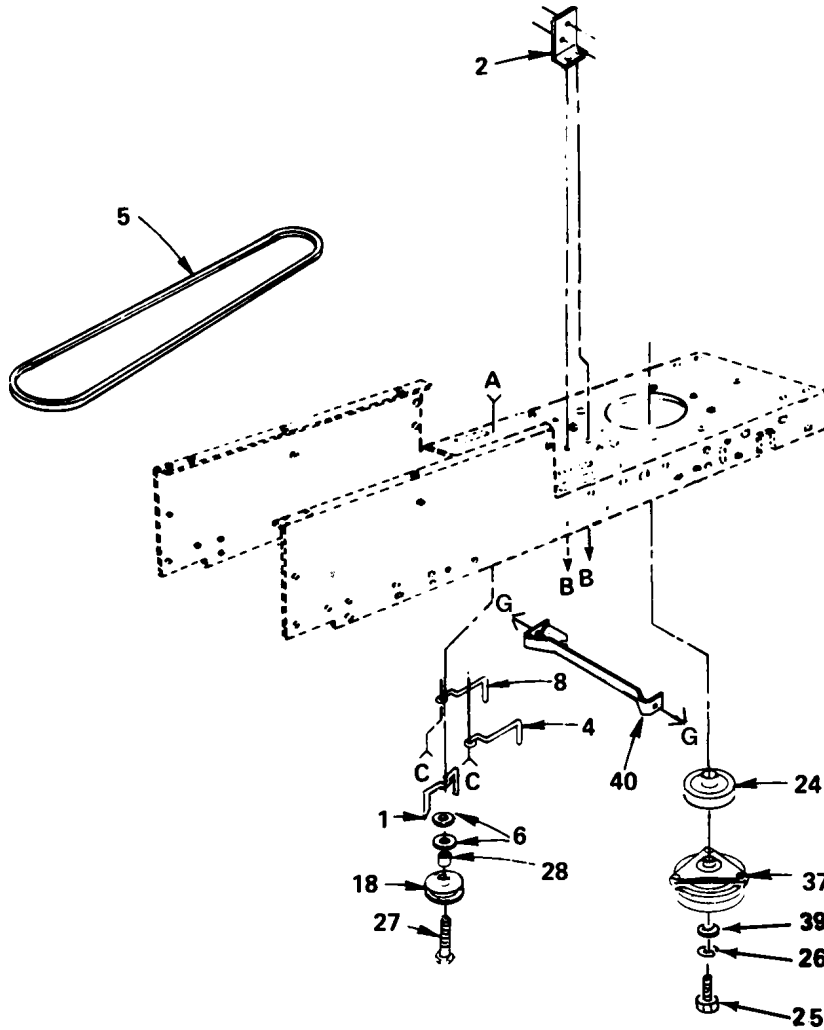

- A-11
- B-3
- C-9,11,36H-60,62
- D-23,38,42
- E-11,12
- G-35,43

# REPAIR PARTS

## 16 HP 44" RIDING TRACTOR - - MODEL NUMBER GT160

### DRIVE GROUP

KEY NO.	PART NO.	DESCRIPTION
1	532109070	Belt, Retainer
2	532108236	Bracket, Switch
3	817021008	Screw, Tap. Hex Hd. #10-24 x 1/2
4	532105730	Keeper, Belt, Engine
5	532123796	V-Belt, Drive
6	819131316	Washer 13/32 x 13/16 x 16 Gauge
8	532121218	Keeper, Belt, Engine
9	819131312	Washer 13/32 x 13/16 x 12 Gauge
10	532121252	Upstop, Mower
11	873680600	Nut, Crownlock 3/8-16
12	872140608	Bolt, Carriage 3/8-16 x 1
15	819171516	Washer 17/32 x 15/16 x 16 Gauge
16	532121599	Arm Assembly, Suspension, L.H.
17	532009135	Spring, Retainer
18	532123674	Idler, Flat
19	873220800	* Nut, Hex 1/2-13
20	532106308	Trunnion, Lift Lower
22	532121598	Arm Assembly, Suspension, R.H.
23	532105848	Bolt, Shoulder 3/8 x 16
24	532123795	Pulley, Engine
25	871130764	Bolt, Hex 7/16-20 x 4 Grade 8
26	810040700	* Washer, Lock 7/16
27	874760644	* Bolt, Hex 3/8-16 x 2-3/4
28	532004470	Spacer
33	532004921	Spring, Retainer
35	873680500	Locknut 5/16-18
36	874760616	* Bolt, Hex 3/8-16 x 1
37	532108218	Clutch, Electric
38	873980600	Nut, Centerlock, Flange 3/8-16
39	532126197	Washer 1-1/2 x 15/32 x 1/4
40	532109169	Locator, Clutch
42	532110739	Washer, Spring
43	872140506	Bolt, Carriage 5/16-18 x 3/4

\* STANDARD HARDWARE - PURCHASE LOCALLY

**NOTE:** All component dimensions given in U.S. inches.  
1 inch = 25.4 mm

# REPAIR PARTS

## 16 HP 44" RIDING TRACTOR - - MODEL NUMBER GT160

### STEERING, FRONT AXLE AND WHEELS

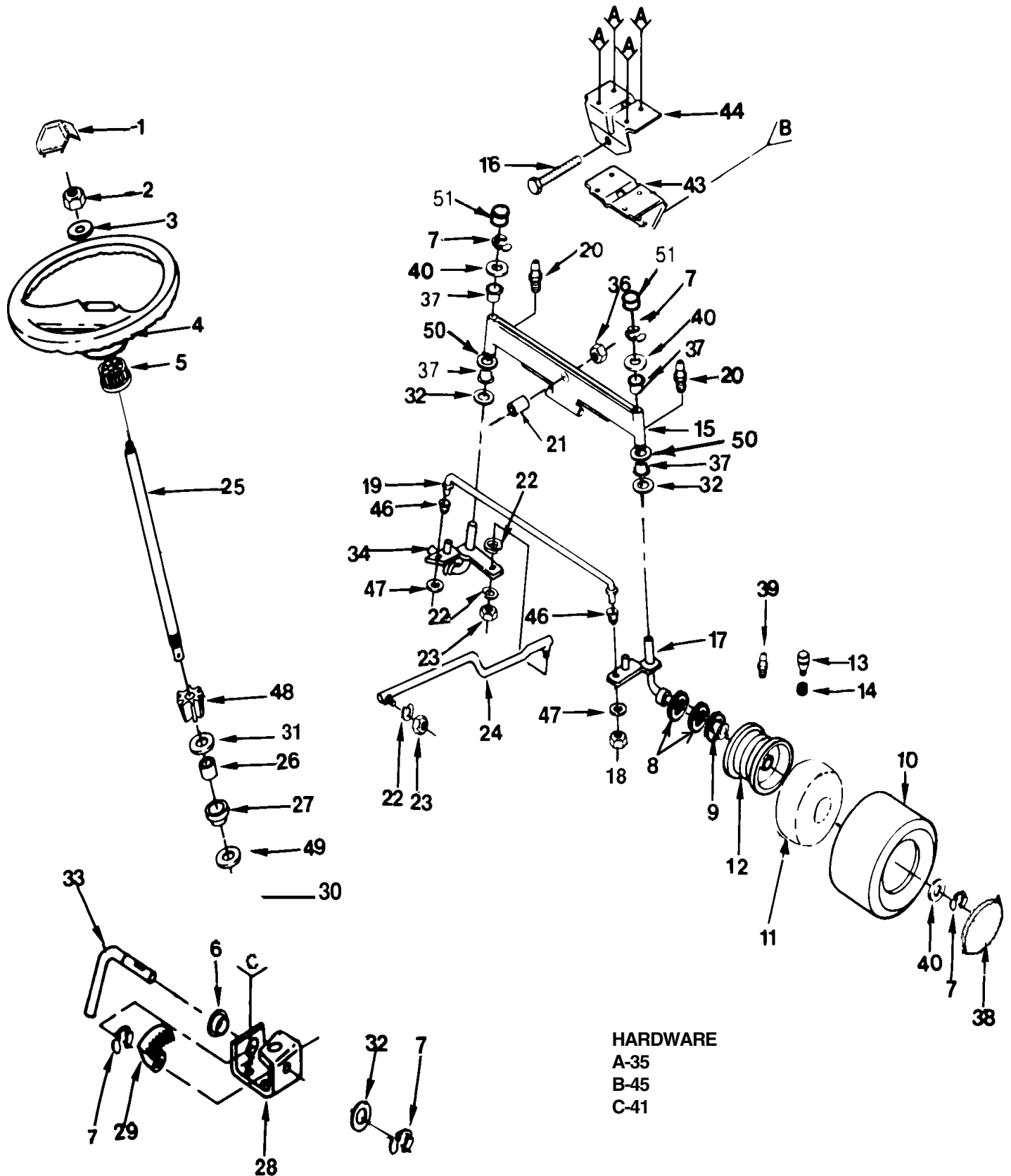



# REPAIR PARTS

## 16 HP 44" RIDING TRACTOR - - MODEL NUMBER GT160

### STEERING, FRONT AXLE AND WHEELS

KEY NO.	PART NO.	DESCRIPTION	KEY NO.	PART NO.	DESCRIPTION
1	532124416	Insert, Steering Wheel	31	532057079	Washer
2	873940800	* Nut, Hex, Jam, Toplock 1/2-20	32	532124931	Thrust, Bearing
3	532100712	Washer 17/32 x 2-1/4 x .160	33	532124033	Shaft, Pitman
4	532124415	Wheel, Steering	34	532105656	Spindle Assembly, L.H.
5	532110711	Adapter, Steering Wheel	35	532122819	Screw, Special 16 x 3/4
6	532109816	Nyliner, Snap In	36	873901000	Nut, Flange 5/8-11
7	812000029	Ring, Klip	37	532003366	Bearing
8	532121749	Washer 25/32 x 1-1/4 x 16 Gauge	38	532124577	Cover, Wheel
9	532009040	Bearings, Wheel, Front	39	532000278	Fitting, Grease
10	532106222	Tire, Front	40	532121748	Washer 25/32 x 1-5/8 x 16 Gauge
11	532059904	Tube, Tire	41	817490612	Screw, Hex Washer Thrdl 3/8-16 x 3/4
12	532124801	Rim Assembly, Front (Inc. 2 each Key # 9)	43	532105664	Support, Saddle, Front
13	532065139	Stem, Valve	44	532105663	Support, Saddle, Rear
14	532059192	Cap, Valve	45	817490508	Screw, Hex Washer Thd. Rolling 5/16-18 x 1/2
15	532108075	Axle Assembly, Front	46	819111216	Washer 11/32 x 3/4 x 16 Gauge
16	874761060	Bolt, Hex 5/8-11 x 3-3/4	47	810040500	* Washer, Lock Heavy Helical Spring
17	532105654	Spindle Assembly, R.H.	48	532124037	Gear, Pinion
18	873810500	Nut, Hex, Nylon 5/16-24 UNF	49	810040400	Washer, Lock 1/4
19	532121334	Rod, Tie	50	819272016	Washer 27/32 x 1-1/4 x 16 Gauge
20	532124836	Fitting, Grease	51	532121232	Cap, Spindle
21	532110438	Spacer, Bearing, Front Axle			
22	810040600	* Lock washer 3/8			
23	873610600	* Nut, Hex 3/8-24			
24	532124032	Link, Drag			
25	532124043	Shaft, Steering			
26	532124035	Support Shaft			
27	532126684	Washer, Shim 1/4 x 5/8 x .062			
28	532124036	Bracket Assembly, Steering			
29	532124034	Gear, Sector			
30	871070410	Screw, Socket Hex 1/4-20 x 5/8			

\* STANDARD HARDWARE - PURCHASE LOCALLY

**NOTE:** All component dimensions given in U.S. inches.  
1 inch = 25.4 mm

# REPAIR PARTS

## 16 HP 44" RIDING TRACTOR -- MODEL NUMBER GT160

### POWER AND MECHANICAL CONTROLS GROUP

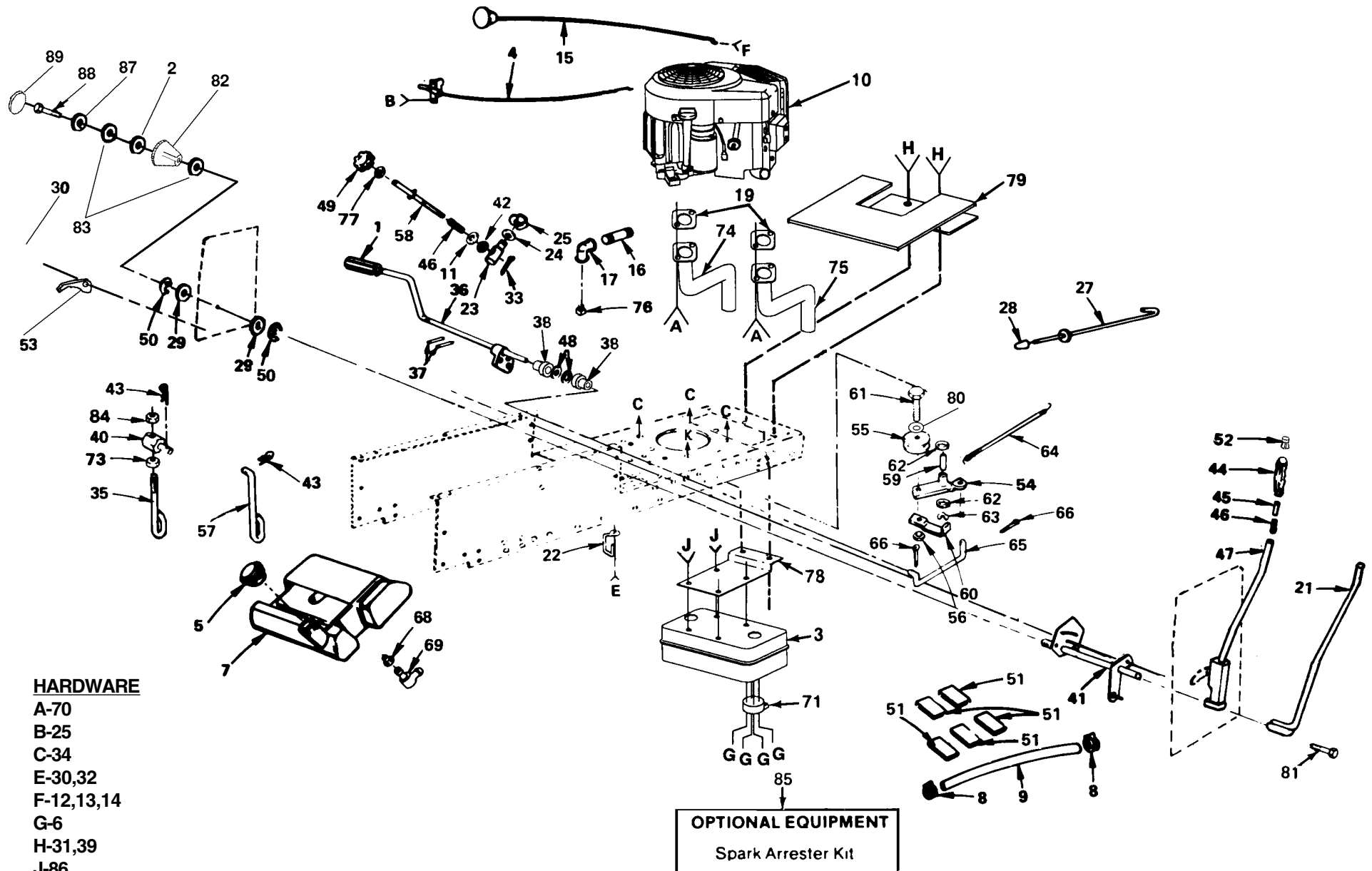

# REPAIR PARTS

## 16 HP 44" RIDING TRACTOR - - MODEL NUMBER GT160

### POWER AND MECHANICAL CONTROLS GROUP

KEY NO.	PART NO.	DESCRIPTION	KEY NO.	PART NO.	DESCRIPTION
1	532123533	Cover, Foot Pedal	47	532121002	Lever Assembly, Hand Kit (Incl. Key No. 21)
2	532120529	Washer, Nylon	48	819211616	Washer 21/32 x 1 x 16 Gauge
3	532122440	Muffler	49	532121891	Handle, Adjust, Lift
4	532122927	Control, Throttle	50	812000022	E-Ring
5	532124462	Cap, Fuel	51	532006431	Pad, Spacer
6	817450808	Screw, Spider Lock	52	532124526	Button, Plunger
7	532127334	Tank, Fuel	53	532124763	Pointer, Height Indicator
8	532123487	Clamp, Hose	54	532123789	Arm Assembly, Idler
9	532008542	Line, Fuel	55	532123766	Pulley, Idler
10	532122436	Engine, Briggs & Stratton 16 HP, Model Number 303777 Type No. 0015-02	56	873680600	Locknut 3/8-16
11	819131016	Washer 13/32 x 5/8 x 16 Gauge	57	532110029	Link, Lift
12	873610600	Nut, Hex 3/8-24	58	532110729	Rod, Adjust, Lift
13	811050600	* Washer, Lock, External Tooth 3/8	59	532105706	Bearing
14	819131316	* Washer 13/32 x 13/16 x 16 Gauge	60	532123205	Retainer, Belt
15	532122926	Control, Choke	61	874760624	* Bolt, Hex 3/8-16 x 1-1/2
16	813280336	Nipple, STD Pipe	62	532110812	Washer, Hardened
17	813200300	Elbow, 90° 3/8 NPT	63	812000039	Ring, Klip
19	—	Gasket, Muffler (see engine pages for replacement number)	64	532105709	Spring, Return, Clutch
21	532121006	Rod Assembly, Lever	65	532105710	Link, Clutch
22	532123788	Retainer, Belt, Chassis, L.H.	66	876020412	Pin, Cotter 1/8 x 3/4
23	532110810	Trunnion, Stop, Depth	68	532124952	Bushing
24	819151216	Washer 15/32 x 3/4 x 16 Gauge	69	532124951	Stem, Tank, Fuel
25	812000037	Ring, Klip	70	—	Bolt, Metric (see engine pages for replacement number)
26	817080408	Screw, Hex Washer Hd. Thread Cutting 1/4-20 x 1/2	71	532101326	Deflector, Muffler
27	532125637	Rod, Brake, Park	73	873360700	Nut, Hex, Jam 7/16-20
28	532071673	Cap, Plunger	74	532122434	Tube Assembly, Exhaust, L.H.
29	819292016	Washer 29/32 x 1-1/4 x 16 Gauge	75	532122435	Tube Assembly, Exhaust, R.H.
30	817490612	Screw, Hex Washer Thread Rolling 3/8-16 x 3/4	76	----	Plug, Drain, Oil (Supplied by Eng. Manufacturer)
31	819131614	* Washer 13/32 x 1 x 14 Gauge	77	873350600	Nut, Hex, Jam 3/8-16
32	819131316	Washer 13/32 x 1-3/16 x 16 Gauge	78	532122439	Bracket, Muffler, Mounting
33	876020308	Pin, Cotter 3/32 x 1/2	79	532122981	Shield, Heat
34	817490624	Screw, Hex Washer Hd. Thd. Rolling 3/8-16 x 1-1/2 Type TT	80	819131316	Washer 13/32 x 13/16 x 16 Gauge
35	532110448	Lift, Link, Adjustable	81	874780624	Bolt, Hex 3/8-16 x 1-1/2
36	532122424	Shaft, Pedal, Foot	82	532123934	Scale, Height Indicator
37	532001572	Pin, Roll 3/16 x 1	83	819112410	Washer 11/32 x 1-1/2 x 10 Gauge
38	532120183	Bearing, Nylon	84	873710700	Nut, Crownlock 7/16-20
39	817490512	Screw 5/16-18 x 3/4	85	532121851	Spark Arrestor Kit
40	532110447	Trunnion, Lift	86	817490408	Screw, Hex Washer Hd. Thread Cutting 1/4-20 x 1/2
41	532124516	Shaft Assembly, Lift	87	810040500	Washer, Lock
42	532110807	* Nut, Special	88	874780516	Bolt, Hex 5/16-18 x 1
43	532124670	Retainer, Spring	89	532123935	Plug, Hole
44	532109413	Grip, Handle	---	532123161	Decal, Engine Instruction
45	532122364	Plunger, Lever, Lift	---	532125971	Decal, Air Cleaner, HP
46	532124874	Spring			

\* STANDARD HARDWARE - PURCHASE LOCALLY  
**NOTE:** All component dimensions given in U.S. inches.  
 1 inch = 25.4 mm

# REPAIR PARTS

## 16 HP 44" RIDING TRACTOR -- MODEL NUMBER GT160

### MOWER

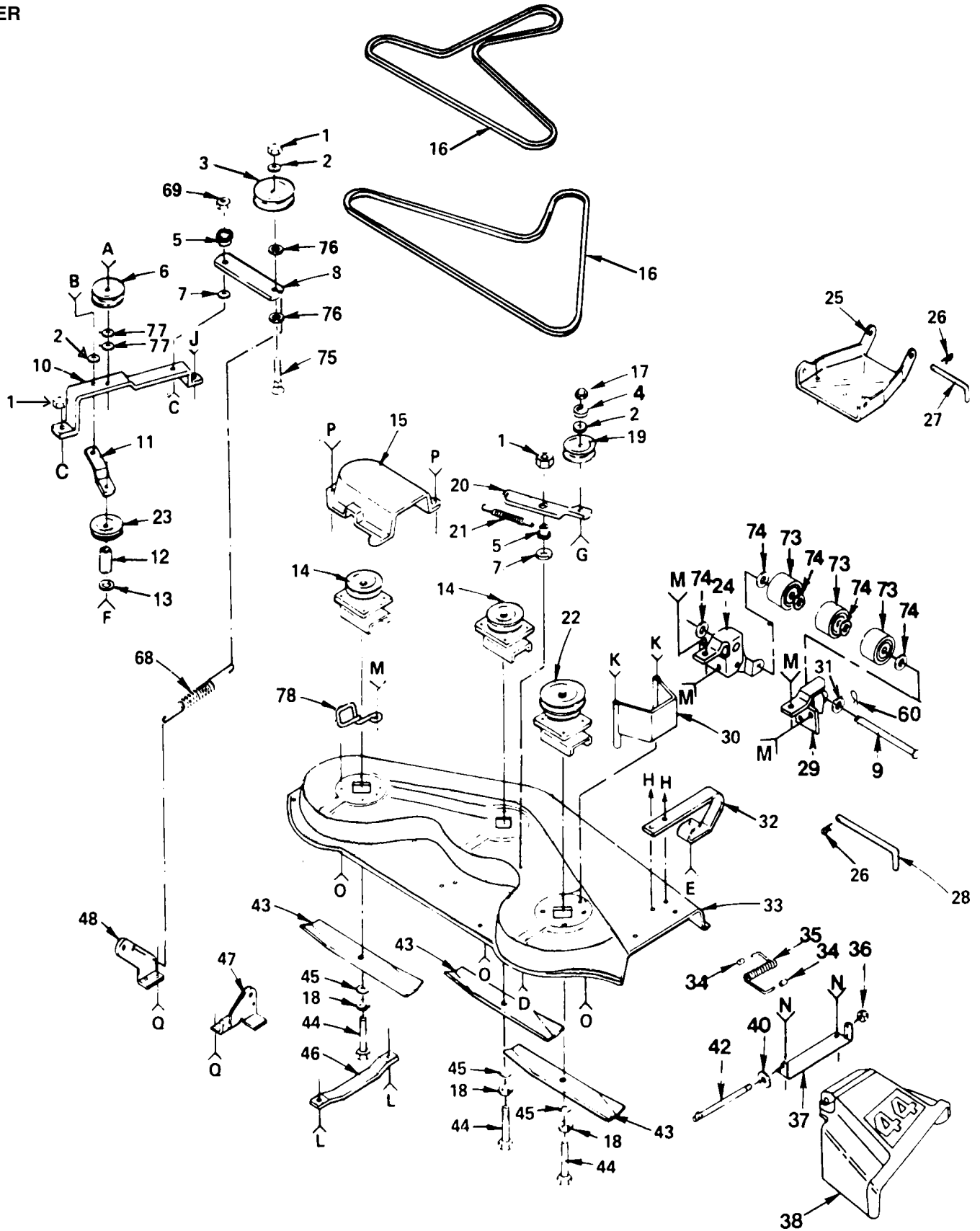

#### HARDWARE

A-1,2,51  
 B-1,52  
 C-53  
 D-54

E-55,56,72  
 F-1,58  
 G-59  
 H-55,72

J-1,80  
 K-61,62,57  
 L-57,79  
 M-55,57,61

O-66  
 P-56,57,70  
 Q-1,67

# REPAIR PARTS

## 16 HP 44" RIDING TRACTOR - - MODEL NUMBER GT160

### MOWER

KEY NO.	PART NO.	DESCRIPTION	KEY NO.	PART NO.	DESCRIPTION
1	873680600	* Nut, Crownlock 3/8-16	45	819132012	Washer 13/32 x 1-1/4 x 12 Gauge
2	819131614	Washer 13/32 x 1 x 14 Gauge	46	532125074	Runner, L.H.
3	532121316	Pulley, Idler	47	532123807	Bracket, Suspension, Rear, R.H.
4	810040600	* Washer, Lock 3/8	48	532123808	Bracket, Suspension, Rear, L.H.
5	532106902	Spacer	51	872140614	* Bolt, Carriage 3/8-16 x 1-3/4
6	532124858	Pulley, Idler	52	872140608	* Bolt, Carriage 3/8-16 x 1
7	532106513	Washer, Wear	53	872140612	* Bolt, Carriage 3/8-16 x 1-1/2
8	532121425	Arm, Idler	54	874760620	* Bolt, Hex 3/8-16 x 1-1/2
9	532109776	Pin, Pivot	55	872140506	* Bolt, Carriage 5/16-18 x 3/4
10	532106523	Bar, Support, Idler	56	819111116	* Washer 11/32 x 11/16 x 16 Gauge
11	532106522	Brace, Idler, Deck	57	873680500	* Nut, Crownlock 5/16-18
12	532121236	Spacer	58	874760648	* Bolt, Hex 3/8-16 x 3
13	819131316	* Washer 13/32 x 13/16 x 16 Gauge	59	874110632	Screw, Flat Head 3/8-16 x 2
14	532121658	Mandrel, Secondary	60	876020412	* Pin, Cotter 1/8 x 3/4
15	532106214	Guard	61	819111216	* Washer 11/32 x 3/4 x 16 Gauge
16	532106085	V-Belt	62	874760580	* Bolt, Hex 5/16-18 x 5
17	873220600	* Nut, Hex 3/8-16	66	817490612	Screw, Hex, Washer Thrdrol. 3/8-16 x 3/4
18	810030600	* Washer, Lock 3/8	67	872140606	* Bolt, Carriage 3/8-16 x 3/4
19	532102932	Idler, Flat	68	532102727	Spring, Extension
20	532106526	Arm, Idler, Deck	69	873930600	* Nut, Centerlock 3/8-16
21	532124885	Spring, Extension	70	872110506	* Bolt, Carriage 5/16-18 x 3/4
22	532121705	Mandrel, Primary	72	532124949	Locknut 5/16-18
23	532102403	Pulley, Idler	73	532109729	Roller, Nose
24	532109599	Bracket, Lift, L.H.	74	819151610	Washer 15/32 x 1 x 10 Gauge
25	532105662	Link, Parallel	75	872140620	* Bolt, Carriage 3/8-16 x 2-1/2
26	532004921	Retainer, Spring	76	819131210	Washer 13/32 x 3/4 x 10 Gauge
27	532105744	Pin, Front, Hinge	77	819131410	Washer 13/32 x 7/8 x 10 Gauge
28	532109835	Pin, Rear, Hinge	78	532121352	Keeper, L.H., Mandrel, Belt
29	532109600	Bracket, Lift, R.H.	79	872110505	* Bolt, Carriage 5/16-18 x 5/8
30	532108119	Guard, Belt, R.H.	80	874760616	* Bolt, Fin, Hex 3/8-16 x 1
31	819151616	* Washer 15/32 x 1 x 16 Gauge	—	532121826	Mower Deck, Complete
32	532124950	Runner, R.H.	—	532108592	Decal, Belt Instruction
33	532121423	Housing, Mower	—	532105185	Decal, Caution (Rotating Blades)
34	532105304	Cap, Sleeve	—	532121349	Decal, Danger (Cut Fingers)
35	532106734	Spring			
36	532110452	Nut, Push			
37	532109743	Bracket, Deflector			
38	532109785	Guard, Discharge			
40	819111016	* Washer 11/32 x 5/8 x 16 Gauge			
42	532106735	Rod, Hinge			
43	532106635	Blade, Mower			
44	874610624	* Bolt, Hex 3/8-24 x 1-1/2 Grade 5			

\* STANDARD HARDWARE - PURCHASE LOCALLY

**NOTE:** All component dimensions given in U.S. inches.  
1 inch = 25.4 mm

# REPAIR PARTS

## 16 HP 44" RIDING TRACTOR - - MODEL NUMBER GT160

### TRANSAXLE AND REAR WHEEL

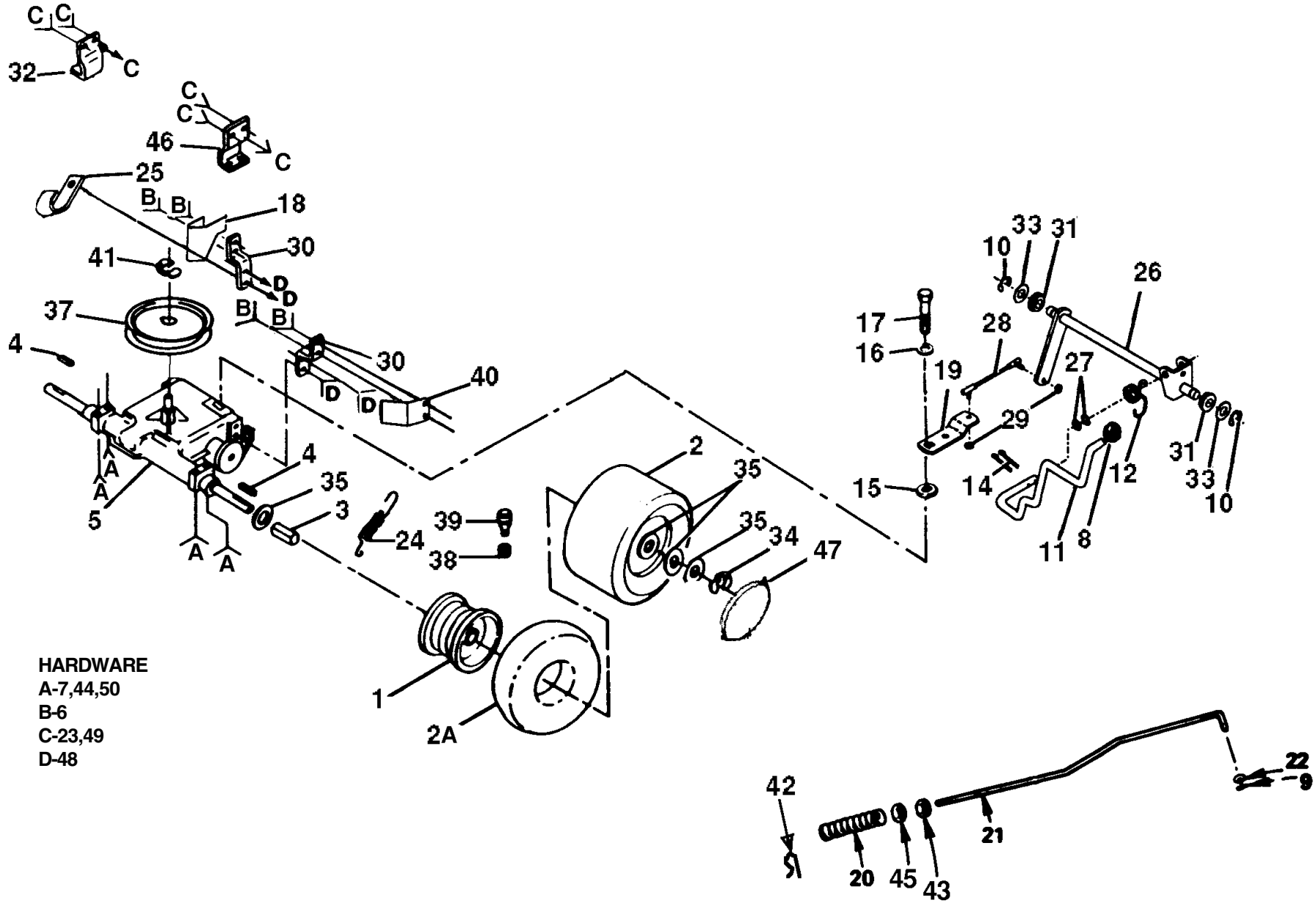

# REPAIR PARTS

## 16 HP 44" RIDING TRACTOR - - MODEL NUMBER GT160

### TRANSAXLE AND REAR WHEEL

KEY NO.	PART NO.	DESCRIPTION	KEY NO.	PART NO.	DESCRIPTION
1	532124802	Rim Assembly, Rear	29	873530400	Nut 1/4-28
2	532124106	Tire	30	532123787	Strap, Torque
2A	532007154	Tube, Tire	31	532071208	Bushing, Steering Rod
3	532108097	Spacer, Split	32	532123780	Bracket, Transaxle, L.H.
4	532124762	Key, Square 1/4 x 2	33	819212016	Washer 21/32 x 1-1/4 x 16 Gauge
5	532123797	Transaxle, 6 Speed, Peerless Model No. 820-016	34	812000053	E-Ring
6	817490612	Screw, Hex Washer Hd. Thread Rolling 3/8-16 x 3/4	35	532123800	Washer 1-1/32 x 1-5/8 x 16 Gauge
7	819111214	Washer 11/32 x 3/4 x 14 Gauge	37	532121327	Pulley, Transaxle
8	532106933	Knob, Control	38	532059192	Cap, Valve
9	876020412	* Pin, Cotter 1/8 x 3/4	39	532065139	Stem, Valve
10	812000008	Ring, Klip	40	532123792	Keeper, Belt, Transaxle, R.H.
11	532123781	Rod, Shifter	41	812000004	Ring, Retainer
12	532123782	Spring, Torsion	42	532124788	Clip, Hairpin
14	876020416	Pin, Cotter 1/8 x 1	43	873350600	Nut, Hex, Jam 3/8-16
15	532105701	Washer, Shift Plate	44	874780544	* Bolt, Hex 5/16-18 x 2-3/4
16	819091216	Washer 9/32 x 3/4 x 16 Gauge	45	873800600	Locknut, Hex Washer Insert 3/8-16
17	871040412	Bolt, Hex 1/4-28 x 3/4 x 16 Grade 8	46	532123776	Bracket, Transaxle, R.H.
18	532123791	Keeper, Belt, Transaxle, L.H.	47	532124579	Cover, Wheel
19	532123794	Arm, Shift	48	817490512	Screw, Hex Washer Hd. Thd. Form. 5/16-18 UNC x 3/4 Type TT
20	532126909	Spring, Rod, Brake	49	874760612	* Bolt, Hex 3/8-16 x 3/4
21	532123786	Rod, Brake	50	873680500	Locknut 5/16-18
22	819131316	* Washer 13/32 x 13/16 x 16 Gauge			
23	873680600	* Locknut 3/8-16			
24	532110422	Spring, Brake Return			
25	532124996	Clip			
26	532123772	Shaft, Arm Shifter			
27	819171216	Washer 17/32 x 3/4 x 16 Gauge			
28	532123793	Rod, Tie			

\* STANDARD HARDWARE - PURCHASE LOCALLY

**NOTE:** All component dimensions given in U.S. inches.  
1 inch = 25.4 mm