

YTH 142



1.1992

Spare parts

Ersatzteile

Pièces détachées









Reserve onderdelen

Repuestos

Reservdelar

ELECTRICAL

A

- A**  9
- B**  30
- C**  45
 46
- D**  35
 40
 36
- F**  35
 22

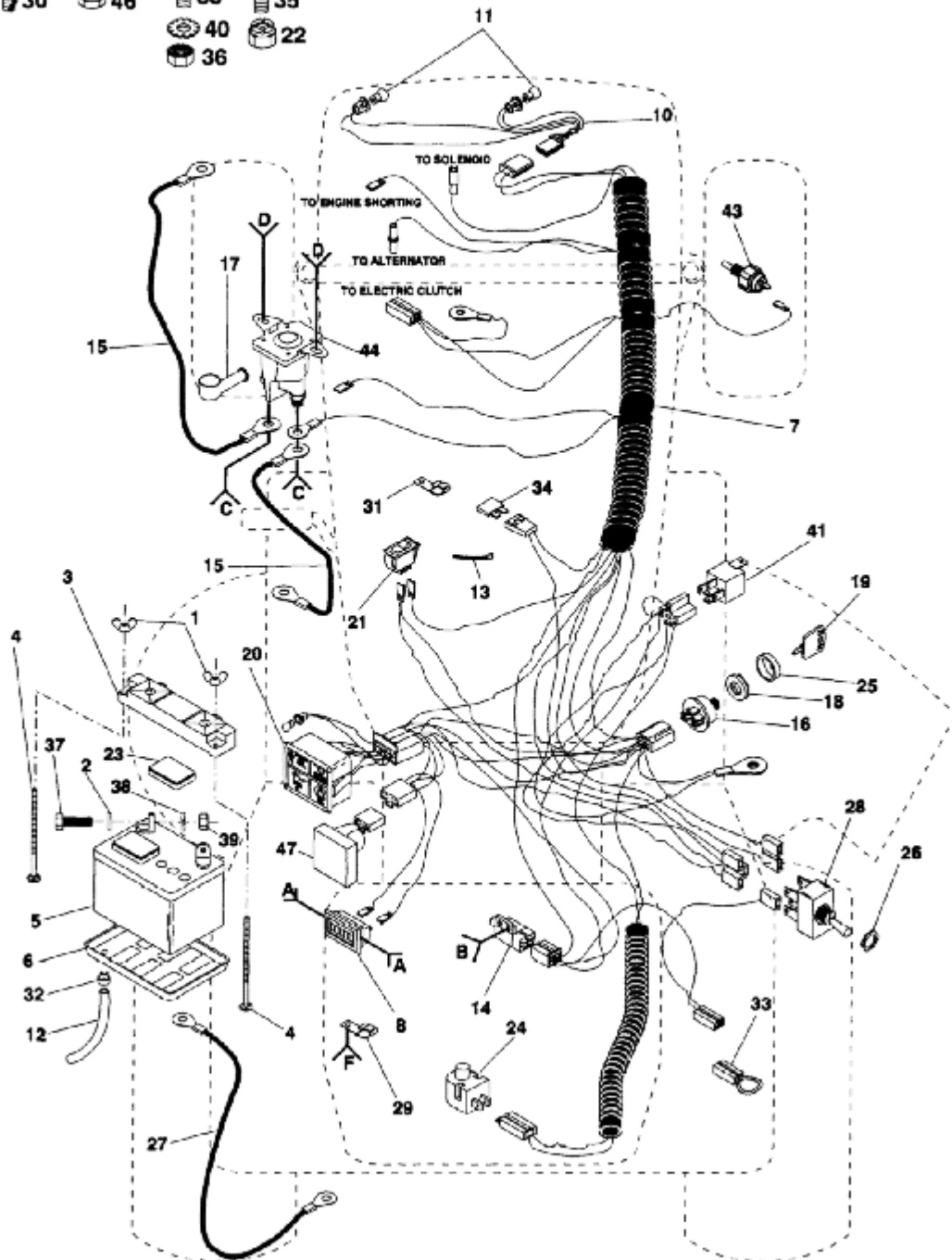

ELECTRICAL



KEY PART NO.	NO.	DESCRIPTION
1	532 12 31-98	Nut, Wing 1/4-20
2	819 09 10-16	Washer 9/32 x 5/8 x 16 Gauge
3	532 10 24-76	Guard, Terminal
4	872 24 04-60	Bolt, Carriage 1/4-20 x 7-1/2
5	532 12 15-37	Battery AYP
5	506 78 88-01	Battery Husqvarna
6	532 12 48-86	Tray, Battery
7	532 13 15-64	Harness, ignition (Includes Key #41)
8	532 11 09-40	Meter, Hour
9	871 01 10-07	Screw #10-24 x 7/16
10	532 12 74-41	Harness, Socket Light
11	532 00 76-62	Bulb, Light
12	532 00 76-97	Tube, Tray Battery
13	532 12 47-56	Tie, Cable
14	532 10 95-53	Switch, Interlock (Clutch)
15	532 12 47-70	Cable, Battery (2)
16	532 10 29-72	Switch, ignition
17	532 13 15-63	Cover, Terminal
18	532 12 42-11	Nut, ignition
19	532 12 21-47	Key, Molded
20	532 12 45-24	Package, Light
21	532 11 07-12	Switch, Light
22	873 68 04-00	Nut, Crownlock 1/4-20
23	532 12 12-64	Caps, Battery
24	532 12 13-05	Switch, Plunger
25	532 12 36-20	Bezel, ignition
26	532 00 40-22	Nut, Hex
27	532 12 47-73	Cable, Battery
28	532 12 60-18	Switch, PTO
29	532 12 49-95	Clip, Insulated
30	817 02 10-08	Screw, Hex, Tap #10-24 UNC
31	532 00 41-71	Clip, Line Fuel
32	532 10 95-96	Clamp, Hose
33	532 10 25-01	Loop, Wire
34	532 10 88-24	Fuse
35	874 78 04-12	Bolt, Hex 1/4-20 x 3/4
36	873 68 04-00	Nut, Hex 1/4-20
37	874 76 04-12	Bolt, Hex 1/4-20 x 3/4
38	810 04 04-00	Washer, Lock 1/4
39	873 22 04-00	Nut, Hex 1/4-20
40	810 04 04-00	Washer, Lock, External Tooth 1/4
41	532 10 97-48	Relay
43	532 12 68-25	Switch, Oil Sensor
44	532 10 90-81	Solenoid
45	810 04 04-00	Washer, Lock 1/4
46	873 68 04-00	Nut, Hex, Jam 1/4-20
47	532 12 73-85	Sensor, Low Voltage
49	532 11 01-43	Bulb, Light Package

NOTE: All component dimensions given in U.S. inches.
1 inch = 25.4 mm

CHASSIS AND ENCLOSURES

B

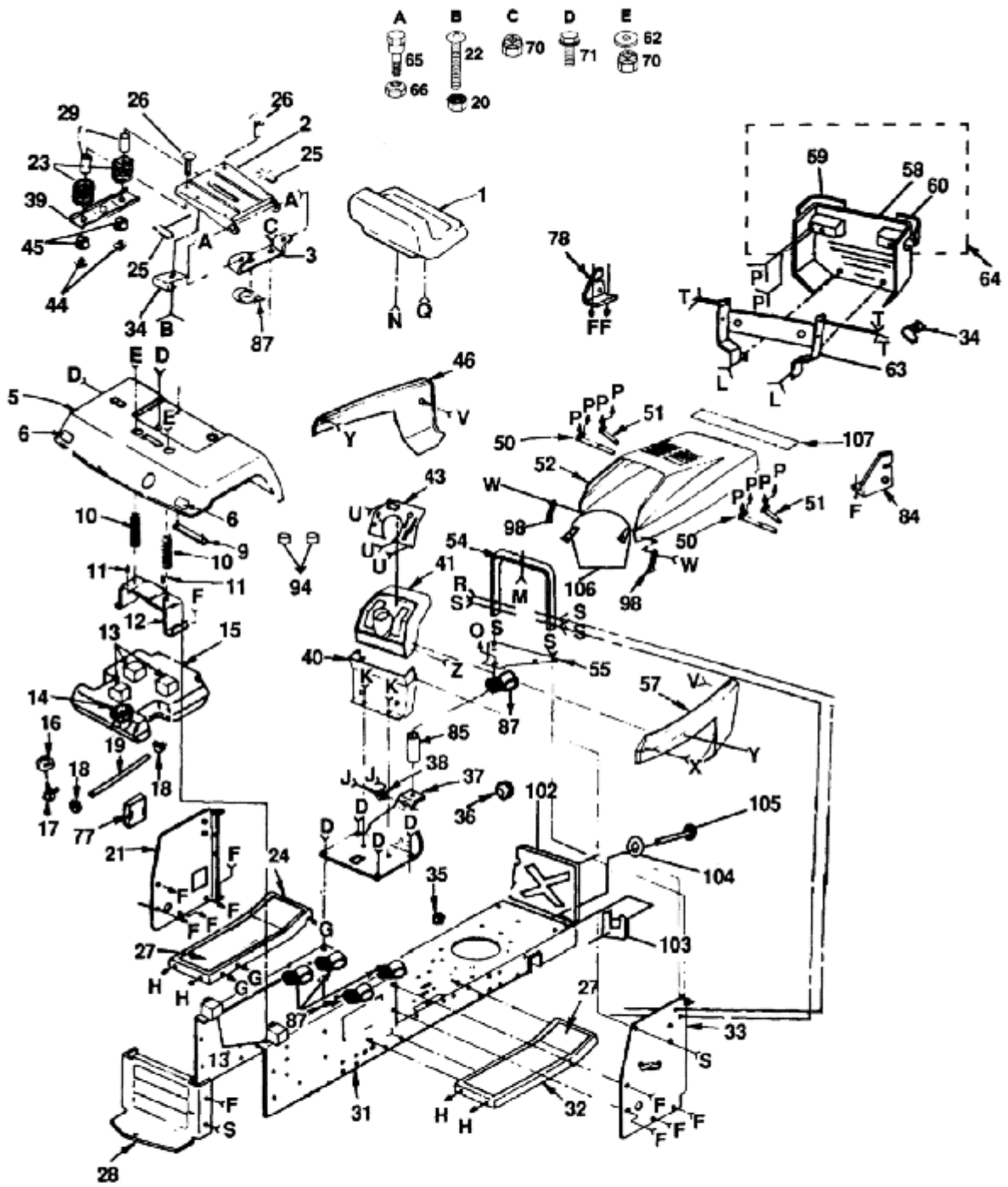

- A 65
- B 22
- C 70
- D 71
- E 62
- 66
- 20
- 70

- F 108
- G 74
- H 96
- J 75
- K 30
- L 8
- M 49
- N 88
- O 82
- 70
- 93
- 70
- 80
- 7
- 4
- 66

- P 79
- Q 73
- R 76
- S 96
- T 88
- U 30
- V 68
- W 48
- X 97
- 70
- 69
- 67
- 70
- 89
- 82
- 60
- 81
- 90
- 91
- 42
- 100
- 101
- 99
- Y 61
- Z 76
- 56
- 93
- 93
- 70

CHASSIS AND ENCLOSURES



KEY PART NO. NO.	DESCRIPTION	KEY NO.	PART NO.	DESCRIPTION
1	532 12 41-86	58	532 12 73-20	Grill
2	532 12 42-94	59	532 12 42-50	Lens, L.H.
3	532 12 66-56	60	532 12 42-51	Lens, R.H.
4	819 09 14-13	61	810 04 04-00	Washer, Lock Tooth Int/External 1/4
5	532 12 49-27	62	819 13 20-12	Washer 13/32x 1 x 14 Gauge
6	532 10 62-02	63	532 12 45-74	Support, Grill, Assembly
7	532 12 12-35	64	532 12 73-20	Assembly, Grill (Inc. Key 59 & 60)
8	874 76 04-44	65	532 10 55-29	Bolt, Shoulder 5/16-18
9	532 10 55-11	66	873 68 05-00	Nut, Crownlock 5/16-18
10	532 12 41-81	67	810 04 06-00	Washer, Lock Tooth External 3/8
11	532 10 55-31	68	532 00 12-60	Spacer
12	532 10 55-09	69	819 17 19-12	Washer 17/32 x 1-3/16 x 12 Gauge
13	532 00 64-31	70	873 68 06-00	Nut, Crownlock 3/8-16
14	532 12 44-62	71	817 49 06-08	Screw, Hex Washer Thread Rolling 3/8-16 x 1/2
15	532 10 60-20			Knob, 1/2" Seat
16	532 00 36-45	73	532 12 00-68	Bolt, Carriage 3/8-16 x 3/4
17	532 12 49-51	74	872 11 06-08	Screw, Hex Self Tapping # 10-16 x 1/2
18	532 12 34-87	75	817 21 10-10	Bolt, Hex 3/8-16 x 1 1/2
19	532 00 85-42			Cover, Access
20	873 95 10-00	76	874 76 06-24	Bracket Assembly, L.H.
21	532 12 41-18	77	532 12 17-94	Nut, Keps, Hex 1/4-20 UNC
22	874 64 10-08	78	532 11 08-52	Nut, 5/16-18 UNC
23	532 12 37-40	79	873 68 04-00	Nut, Fin, Hex 1/4-20 UNC
24	532 12 48-99	80	873 68 05-00	Bolt, Hex 5/16-18 x 2 1/2
25	532 12 12-51	81	873 22 04-00	Bracket, Assembly R.H.
26	872 04 04-10	82	874 76 05-40	Spacer
27	532 10 82-56	84	532 11 08-53	Bolt, Shoulder 5/16-18 x .62
28	532 12 78-66	85	532 12 12-36	Clip
29	532 12 12-49	86	532 12 70-18	Bolt, Shoulder 1/4-20
30	874 76 05-14	87	532 00 27-51	Nut, Crownlock 1/4-20
31	532 12 72-13	88	532 00 76-05	Screw, # 10-24 x 1/2
32	532 12 49-14	89	873 68 04-00	Washer, Lock 1/4
33	532 13 37-48	90	817 02 10-08	Washer 11/32 x 11/16 x 16 Gauge
34	532 00 41-71	91	810 04 04-00	Cap, Spring, Seat
35	532 11 04-36	92	819 11 14-16	Washer 13/32 x 13/16 x 12 Gauge
36	532 00 91-51	94	532 12 42-38	Bolt, Hex 3/8-16 x 3/4
37	532 12 11-95	93	819 13 13-16	Screw, Mach. Cr. Pan # 10-24 x 1-3/4
38	532 12 47-20	96	874 76 06-12	Latch, Hood
39	532 12 12-46	97	874 98 10-28	Nut, Keps # 10-24
40	532 10 48-05	98	532 10 98-08	Spacer, Split # 10 x 3/4
41	532 12 41-82	99	873 95 10-00	Washer 9/32 x 1/2 x 16 Gauge
42	532 12 50-04	100	532 00 72-06	Shield, Heat
43	532 12 72-30	101	819 09 08-16	Receptacle, 1/4 Turn
44	532 12 39-76	102	532 10 81-05	Retainer, 1/4 Turn
45	532 12 12-48	103	532 10 58-39	Stud, 1/4 Turn
46	532 12 50-09	104	532 10 58-38	Baffle, Vertical
47	532 11 03-57	105	532 12 36-50	Foam, Strip 18"
48	532 11 03-56	106	532 12 64-93	Screw, Hex Washer, Thread Rolling 3/8-16 x 3/4
49	810 04 04-00	107	532 10 50-37	
50	532 10 67-84	108	874 76 06-12	
51	532 10 46-18			
52	532 12 50-07			
53	532 12 41-30			
54	532 10 69-65			
55	532 12 31-98			
56	532 12 50-08			
57				

NOTE: All component dimensions given in U.S. inches.
1 inch = 25.4 mm

DRIVE

C

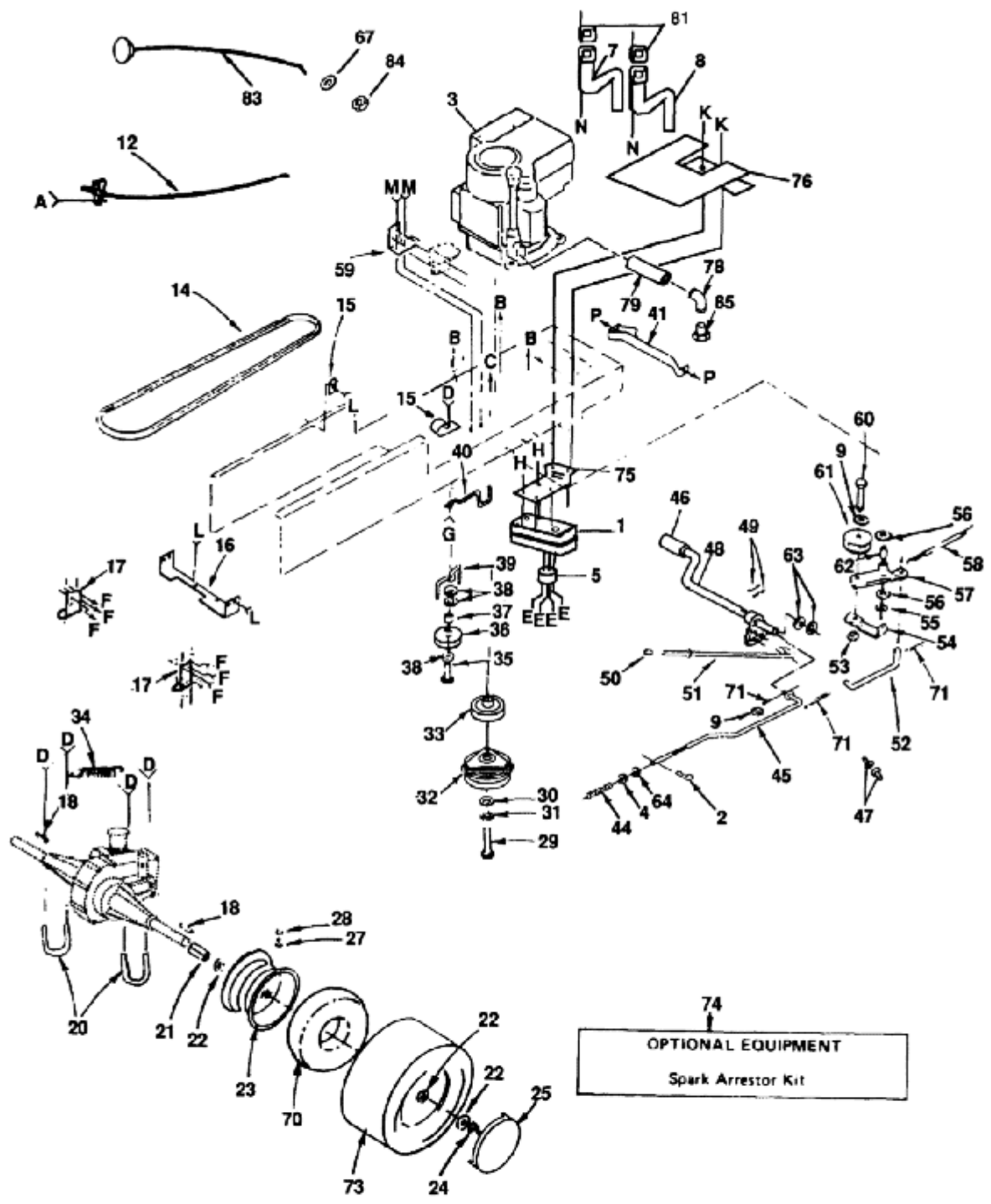

- | | | | | | | | | | | | | |
|----------|----------|----------|----------|----------|----------|----------|----------|----------|----------|----------|----------|----------|
| A | B | C | D | E | F | G | H | K | L | M | N | P |
| | | | | | | | | | | | | |

DRIVE



KEY PART NO	NO	DESCRIPTION	KEY PART NO.	NO.	DESCRIPTION
1	532 12 24-40	Muffler	46	532 12 35-33	Cover, Pedal
2	532 12 47-88	Clip Hairpin	47	532 12 01-83	Bearing, Nylon
3	-----	Engine, Briggs & Stratton, Vanguard Model #303777	48	532 12 24-24	Shaft, Foot Pedal, Assembly
4	873 35 06-00	Nut, Hex, Jam 3/8 x 16 UNC	49	532 00 28-82	Pin, Roll 3/16 x 1
5	532 10 13-26	Deflector	50	532 07 16-73	Cap, Plunger
6	817 03 08-08	Screw, Spider Lock, Hex #8 x 1/2	51	532 13 32-61	Rod, Brake, Park
7	532 12 24-34	Tube Manifold, L.H.	52	532 10 57-10	Link, Clutch
8	532 12 24-35	Tube Manifold, R.H.	53	873 68 06-00	Nut, Crownlock 3/8-16
9	819 13 13-16	Washer 13/32 x 13/16 x 16 Gauge	54	532 12 32-05	Retainer, Belt
10	873 68 05-00	Nut, Crownlock 5/16-18	55	812 00 00-39	Ring, Klip
11	872 14 05-06	Bolt, Carriage 5/16-18 x 3/4	56	532 11 08-12	Washer, Hardened
12	532 13 27-63	Control, Throttle	57	532 12 37-89	Arm, Assembly, Idler (Include Key No. 62)
14	532 12 34-61	V-Belt, Drive	58	532 10 57-09	Spring, Return, Clutch
15	532 00 27-51	Clip	59	532 10 82-36	Bracket, Switch
16	532 12 11-87	Bracket, Mounting, Hydro T/A	60	874 76 06-24	Bolt, Hex 3/8-16x 1-1/2
17	532 12 66-49	Bracket, Transaxle	61	532 12 77-83	Pulley, Idler
18	532 12 35-83	Key, Square 1/4 x 2	62	532 10 57-06	Bearing
19	819 13 20-12	Washer 13/32 x 1 x 14 Gauge	63	819 21 16-16	Washer 21/32 x 1 x 16 Gauge
20	532 12 11-89	U-Bolt 3/8-16x2.83	64	873 68 06-00	Locknut, Hex W/Wash 3/8-16
21	532 12 11-99	Spacer, Split	65	874 76 04-12	Screw, Hex Thread Cut. 1/4-20 x 5/8
22	532 12 17-48	Washer 1-1/32 x 1-5/8 x 16 Gauge	66	874 76 06-24	Screw, Hex Washer Thread Rolling 3/8-16 x 1-1/2
23	532 10 61-08	Rim, Rear	67	810 04 06-00	Washer, Lock External Tooth 3/8
24	812 00 00-01	E-Ring	68	874 76 06-12	Bolt, Hex 3/8-16x314
25	532 12 45-78	Cover, Wheel	69	874 76 06-24	Bolt, Hex 3/8-16 x 1
27	532 06 51-39	Stem, Valve	70	532 12 49-26	Tube
28	532 05 91-92	Cap, Valve	71	876 02 04-16	Pin, Cotter 1/8 x 3/4
29	871 13 07-68	Bolt, Hex, Fin 7/16-20 UNF x 4 Grade 8	72	874 76 06-12	Screw, Hex, Thdrol 3/8-16 x 3/4
30	532 12 61-97	Washer 1-1/2 OD x 15/32 ID x .250	73	532 12 20-74	Tire
31	810 04 07-00	Washer, Lock 7/16	74	532 12 18-51	Spark, Arrestor Kit
32	532 10 82-18	Clutch, Electric	75	532 12 24-39	Bracket, Muffler Mounting
33	532 12 37-95	Pulley, Engine	76	532 12 29-81	Shield, Heat
34	532 11 04-22	Spring, Brake Return	77	817 49 05-12	Screw, Hex, Washer Thrdrol 5/16-18 x 3/4
35	874 76 06-44	Bolt, Hex 3/8-16x2-314	78	813 20 03-00	Elbow, STD 90° 3/8-18NPT
36	532 00 48-59	Idler, Flat	79	813 28 03-36	Nipple, Pipe
37	532 00 44-70	Spacer	80	817 19 04-08	Screw, Hex, Washer Thrdrol 1/4-20
38	819 13 13-16	Washer 13/32 x 13/16 x 12 Gauge	81	-----	Gasket (Order from Engine Mfg..)
39	532 10 90-70	Retainer, Belt	82	-----	Bolt, Metric (Order from Engine Mfg.)
40	532 12 99-21	Keeper, Belt, Engine	83	532 13 27-81	Choke Control
41	532 10 91-69	Retainer, Clutch Assembly	84	873 61 06-00	Nut, Hex 3/8-24 UNF
43	817 02 10-08	Screw, Tap. Hex Hd, #10-24 x 1/2 Type T	85	-----	Plug, Oil Drain (Order from Engine Manufacturer)
44	532 10 68-88	Spring, Rod, Brake			
45	532 12 12-00	Rod, Brake			

NOTE: All component dimensions given in U.S. inches.
1 inch = 25.4 mm

STEERING ASSEMBLY

D

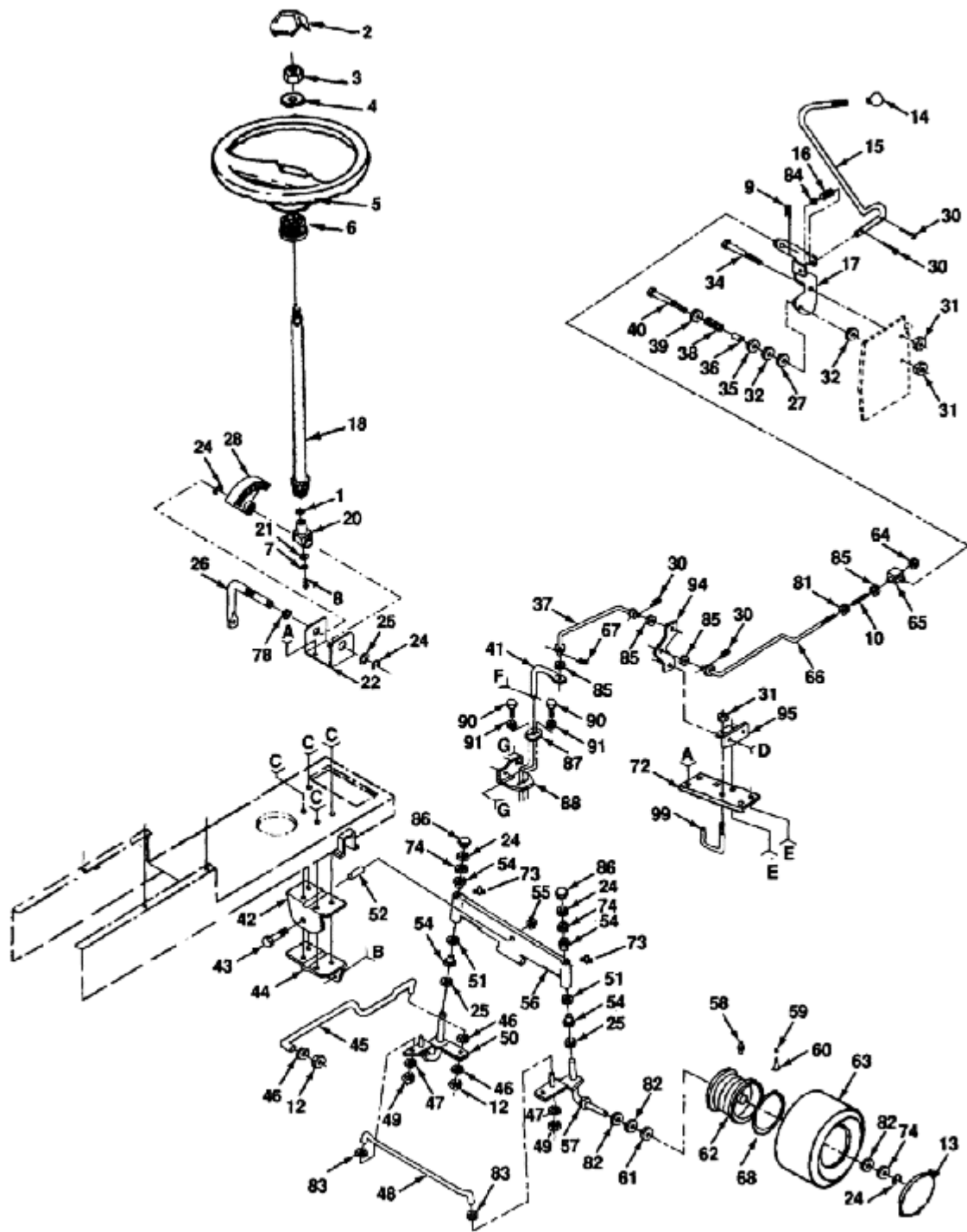

- A 33
- B 71
- C 53
- D 96
98
- E 97
31
- F 92
93
- G 89

STEERING ASSEMBLY



KEY PART NO. NO.	DESCRIPTION	KEY PART NO. NO.	DESCRIPTION
1	532 05 70-79 Washer	53	532 12 28-19 Screw, Special 3/8-16 x 3/4
2	532 12 44-16 Insert, Steering Wheel	54	532 12 49-37 Bearing
3	873 36 08-00 Nut, Jam, Toplock 1/2-20	55	873 90 10-00 Nut, Jam Lock Hex W/Washer 5/8-16
4	532 10 07-12 Washer	56	532 10 80-75 Axle, Front
5	532 12 44-15 Wheel, Steering	57	532 13 04-59 Spindle, R.H.
6	532 10 07-11 Adapter, Steering Wheel	58	532 00 02-78 Fitting, Grease
7	810 04 04-00 Washer, Lock 1/4	59	532 06 51-39 Stem, Valve
8	874 76 04-12 Screw, Socket, Hex 1/4-20 x 5/8	60	532 05 91-92 Cap, Valve
9	532 00 49-21 Spring, Retainer	61	532 00 90-40 Bearing
10	532 10 26-70 Spring, Compression	62	532 10 67-32 Rim, Front
12	873 61 06-00 Nut, Hex, Fin 3/8-24 UNF	63	532 10 62-22 Tire, Front
13	532 12 45-77 Cover, Wheel	64	873 68 06-00 Locknut, Hex, w/Wsh. 3/8-16
14	532 12 12-74 Knob, Gear Shift	65	532 10 82-12 Trunnion
15	532 11 08-45 Rod, Control	66	532 12 17-50 Rod, Control, Adjustable
16	532 12 16-31 Spring, Torsion	67	532 12 47-88 Clip, Hairpin
17	532 10 81-96 Bracket, Control Rod	68	532 05 99-04 Tube, Tire Front
18	532 12 87-62 Shaft, Steering	71	817 49 05-08 Screw, Hex Washer Thread Rolling 5/16-18 x 1/2
20	532 12 40-35 Support, Shaft	72	532 12 31-86 Bracket, Chassis, Reinforcement, Hydro
21	532 12 66-84 Washer, Shim 1/4 x 5/8 x .062	73	532 12 48-36 Fitting, Grease
22	532 12 40-36 Bracket, Steering	74	532 12 17-48 Washer 25/32 x 1-5/8 x 16 Gauge
24	812 00 00-29 Ring, Klip	78	532 10 98-16 Nyliner, Snap-In
25	532 12 49-31 Bearing, Thrust	81	819 13 12-10 Washer 13/32 x 3/4 x 12 Gauge
26	532 12 75-01 Shaft, Pitman	82	532 12 17-49 Washer 25/32 x 1-1/4 x 16 Gauge
27	532 10 89-72 Washer, Friction	83	819 11 14-16 Washer 11/32 x 3/4 x 16 Gauge
28	532 12 40-34 Gear, Sector	84	819 15 16-16 Washer 15/32 x 15/16 x 16 Gauge
30	876 02 04-16 Pin, Cotter 118 x 314	85	532 11 07-39 Washer, Spring
31	873 68 06-00 Nut, Crownlock 3/8-16	86	532 12 12-32 Cap, Spindle
32	532 10 82-00 Spacer, Nylon	87	532 12 12-17 Guide, Control
33	874 76 06-12 Screw, Hex Washer Thread Rolling 3/8-16 x 314	88	532 12 12-16 Bracket, Control Guide
34	532 10 85-18 Bolt, Hex Shoulder 3/8-16 x 1-3/8	89	874 76 05-14 Screw, Hex Washer Thread Rolling 5/16-18 x 3/4 Type TT
35	819 21 16-16 Washer 21/32 x 1-1/4 x 16 Gauge	90	817 02 10-08 Screw, Tap Hex Hd. #10-24 UNC x 1/2 Type T
36	532 10 82-01 Spacer	91	819 09 08-16 Washer 7/32 x 1/2 x 16 Gauge
37	532 12 12-02 Link, Control, Pump	92	874 56 10-14 Screw, Hex Socket Hd. #10-24 UNC
38	532 10 88-44 Spring, Compression	93	532 06 91-80 Locknut #10-24 UNC
39	819 13 20-12 Washer 13/32 x 1-1/4 x 12 Gauge	94	532 12 12-04 Bellcrank
40	874 76 06-48 Bolt, Hex 3/8-16 x 3	95	532 12 12-06 Bracket, Bellcrank, Pivot
41	532 12 12-09 Lever, Pump Control	96	532 10 05-36 Bolt, Shoulder
42	532 10 56-63 Support, Saddle, Rear	97	874 76 06-24 Bolt, Hex, Fin 3/8-16 UNC x 1
43	874 76 10-60 Bolt, Hex 5/8-11 x 3-3/4	98	873 68 05-00 Nut, Crownlock 5/16-18
44	532 10 56-64 Support, Saddle, Front	99	532 12 11-90 Keeper, Centerspan
45	532 13 04-68 Link, Drag		
46	810 04 06-00 Washer, Lock 3/8		
47	810 04 05-00 Washer, Lock 5/16		
48	532 13 04-67 Rod, Tie		
49	873 81 05-00 Nut, Hex 5/16-24 UNF		
50	532 13 04-60 Spindle, L.H.		
51	819 27 20-16 Washer 27/32 x 1-1/4 x 16 Gauge		
52	532 11 04-38 Spacer, Bearing		

NOTE: All component dimensions given in U.S. inches.
1 inch = 25.4 mm

LIFT ADJUSTMENT

E

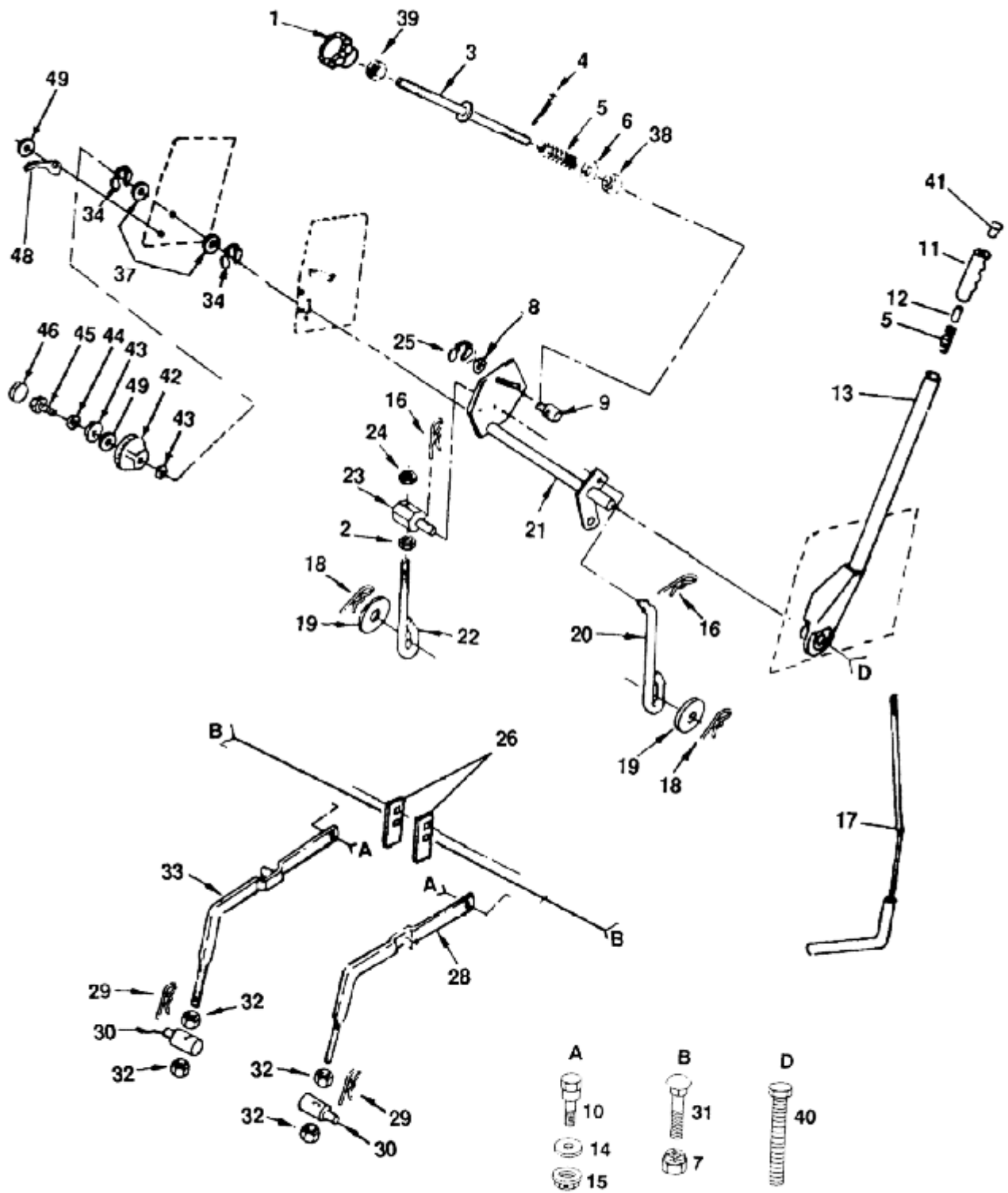

LIFT ADJUSTMENT









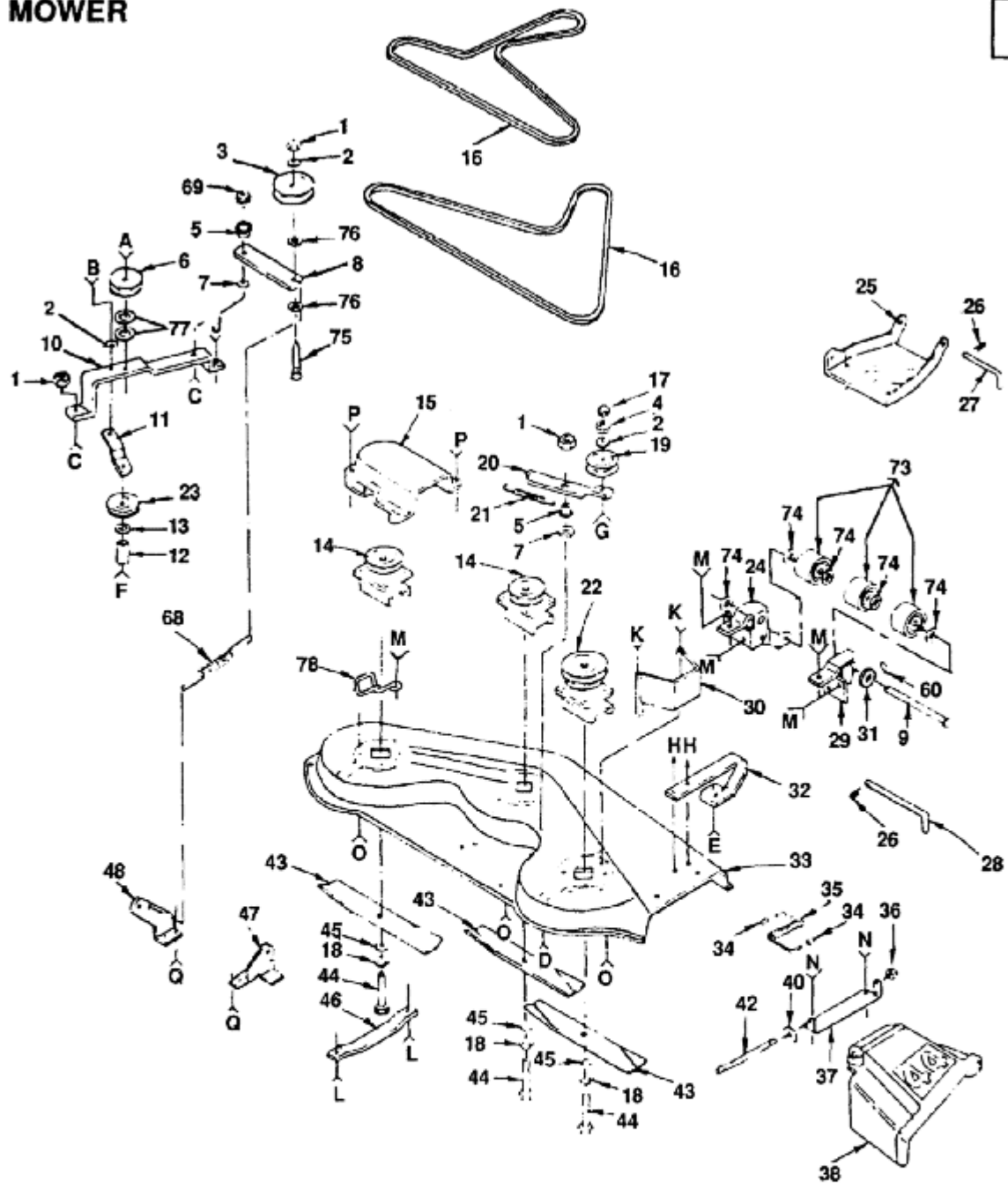

KEY PART NO. NO.	DESCRIPTION
1 532 12 18-91	Handle, Lift, Adjustment
2 873 35 06-00	Nut, Hex 3/8-16
3 532 11 07-29	Rod, Adjust, Lift
4 876 02 03-12	Pin, Cotter 3/32 x 1/2
5 532 12 48-74	Spring
6 819 13 10-16	Washer 13/32 x 5/8 x 16 Gauge
7 873 68 06-00	Nut, Crownlock 3/8-16
8 819 15 12-16	Washer 15/32 x 3/4 x 16 Gauge
9 532 11 08-10	Trunnion, Depth Stop
10 532 10 58-48	Bolt, Shoulder 3/8-16
11 532 12 56-31	Grip, Handle
12 532 12 59-25	Plunger, Lever, Lift
13 532 12 30-96	Lever, Lift
14 532 11 07-39	Spring, Washer
15 873 93 06-00	Nut, Center, Lock, Flange 3/8 x 16
16 532 12 46-70	Retainer, Spring
17 532 12 10-06	Rod, Lever
18 532 00 49-21	Retainer, Spring
19 819 17 16-16	Washer 17/32 x 15/16 x 16 Gauge
20 532 11 00-29	Link, Lift
21 532 13 19-26	Shaft, Lift, Assembly
22 532 11 04-48	Link, Lift, Adjust
23 532 11 04-47	Trunnion, Lift
24 873 71 07-00	Locknut 7/16-20
25 812 00 00-39	Ring, Klip
26 532 12 12-52	Upstop, Mower
28 532 12 15-98	Arm, Suspension, R.H.
29 532 00 91-35	Retainer, Spring
30 532 10 63-08	Trunnion, Lift, Lower
31 872 14 06-12	Bolt, Carriage 3/8-16 UNC x 1
32 873 68 08-00	Nut, Hex, Fin. 1/2-13
33 532 12 15-99	Arm, Suspension, L.H.
34 812 00 00-22	E-Ring, Truarc
37 819 29 20-16	Washer 29/32 x 1-1/4 x 16 Gauge
38 532 11 08-07	Nut, Special
39 873 35 06-00	Nut, Hex, Jam 3/8 x 16 UNC
40 874 76 06-24	Bolt, Hex 3/8-16 x 1-1/2
41 532 12 59-25	Button, Plunger
42 532 12 39-34	Scale, Height, Indicator
43 819 11 24-10	Washer 11/32 x 1-1/2 x 10 Gauge
44 810 04 05-00	Washer, Lock, Heavy, Helical, Spring
45 874 78 05-16	Bolt, Hex, Fin. 5/16-18 UNC x 1
46 532 12 39-35	Plug, Hole
48 532 12 39-33	Pointer, Height Indicator
49 532 12 05-29	Washer, Nylon

NOTE: All component dimensions given in U.S. inches.
1 inch = 25.4 mm

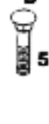
MOWER

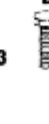
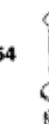
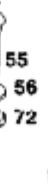
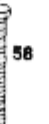
F

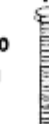
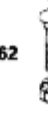
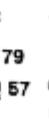
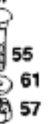
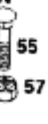
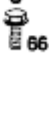

- A**

- B**

- C**

- D**

- E**

- F**

- G**

- H**

- J**

- K**

- L**

- M**

- N**

- O**

- P**

- Q**

MOWER



KEY PART NO. NO.	DESCRIPTION	KEY PART NO. NO.	DESCRIPTION	
1	873 68 06-00	42	532 10 67-35	Rod, Hinge
2	819 13 20-12	43	532 12 22-65	Blade, Mower
3	532 12 13-16	44	874 61 06-24	Bolt, Hex 3/8-24x1-1/2Grade5
4	810 04 06-00	45	819 13 20-12	Washer 13/32x1-1/4x12Gauge
5	532 10 69-02	46	532 12 50-74	Runner, L.H.
6	532 12 48-58	47	532 12 38-07	Bracket, Suspension, Rear, R.H.
7	532 10 65-13	48	532 12 38-08	Bracket, Suspension, Rear, L.H.
8	532 12 14-25	51	872 14 06-14	Bolt, Carriage 3/8-16x1-3/4
9	532 10 97-76	52	872 14 06-12	Bolt, Carriage 3/8-16 x 1
10	532 10 65-23	53	872 14 06-12	Bolt, Carriage 3/8-16x1-1/2
11	532 10 65-22	54	874 76 06-24	Bolt, Hex 3/8-16x1-1/4
12	532 12 12-36	55	872 14 05-06	Bolt, Carriage 5/16-18 x 3/4
13	819 13 13-16	56	819 11 14-16	Washer 11/32 x 11/16 x 16 Gauge
14	532 12 16-58	57	873 68 05-00	Nut, Crownlock 5/16-18
15	532 10 62-14	58	874 76 06-48	Bolt, Hex 3/8-16 x 3
16	532 10 60-85	59	874 76 06-36	Screw, Flat Head 3/8-16 x 2
17	873 35 06-00	60	876 02 04-16	Pin, Cotter
18	810 04 06-00	61	819 11 14-16	Washer 11/32x3/4x16Gauge
19	532 10 29-32	62	874 76 05-80	Bolt, Hex 5/16-18x5
20	532 10 65-26	66	874 76 06-12	Screw, Hex Washer Thread Rolling 3/8-16 x 3/4
21	532 12 48-85	67	872 14 06-12	Bolt, Carriage 3/8-16x3/4
22	532 12 17-05	68	532 10 27-27	Spring, Extension
23	532 10 24-03	69	873 93 06-00	Nut, Centerlock 3/8-16
24	532 10 95-99	70	872 11 05-06	Bolt, Carriage 5/16-18x3/4
25	532 10 56-62	72	532 12 49-49	Locknut 5/16-18
26	532 00 49-21	73	532 10 97-29	Roller, Nose
27	532 10 57-44	74	819 15 16-16	Washer 15/32 x 1 x 10 Gauge
28	532 10 98-35	75	872 14 06-22	Bolt, Carriage 3/8-16x2-1/2
29	532 10 96-00	76	819 13 12-10	Washer 13/32 x 3/4 x 10 Gauge
30	532 10 81-19	77	819 13 16-11	Washer 13/32 x 7/8 x 10 Gauge
31	819 15 16-16	78	532 12 13-52	Keeper, L.H., Mandrel
32	532 12 49-50	79	872 11 05-06	Bolt, Carriage 5/16-18 x 5/8
33	532 12 14-23	80	874 76 06-24	Bolt, Hex, Fin 3/8-16 x 1
34	532 10 53-04	—	532 13 15-08	Mower Deck, Complete
35	532 10 67-34			
36	532 11 04-52			
37	532 10 97-43			
38	532 10 97-85			
40	819 11 14-16			

NOTE: All component dimensions given in U.S. inches.
1 inch = 25.4 mm

TRANSAXLE AND PUMP ASSEMBLY

G

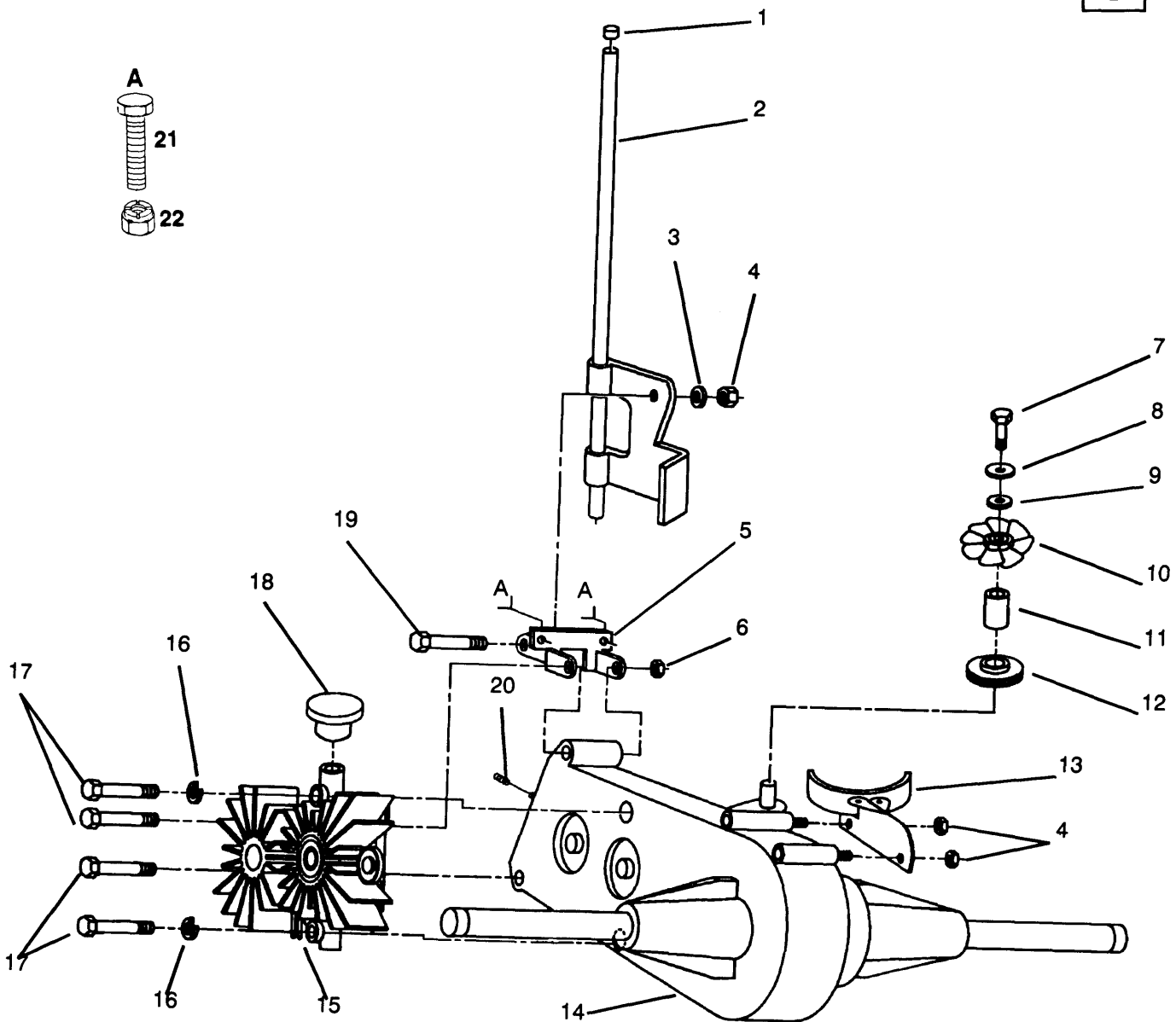

KEY PART NO. NO.

DESCRIPTION

1	532 07 16-73	Cap, Plunger
2	532 12 36-34	Rod, Free Wheel Control Assembly
3	532 12 05-29	Washer, Nylon
4	873 68 04-00	Nut, Crownlock 1/4-20 UNC
5	532 12 11-88	Bracket, Painted, Mounting, Differential
6	873 68 05-00	Nut, Crownlock 5/16-18
7	874 78 04-12	Bolt, Hex 1/4-20 UNC x 3/4
8	810 04 04-00	Washer
9	819 09 14-13	Washer 9/32x1-1/4x16Gauge
10	532 12 11-86	Fan, Hydro, 8"
11	532 12 12-11	Standoff, Fan, Hydro
12	532 12 11-80	Pulley, Transaxle
13	532 12 11-82	Guard Assembly, Belt

KEY PART NO. NO.

DESCRIPTION

14	532 12 14-31	Differential Assembly
15	532 12 14-30	Pump Assembly
16	810 04 05-00	Washer Lock
17	874 76 05-72	Bolt, Hex Fin. 5/6-18 UNC x 4 1/2
18	532 12 13-23	Reservoir, Pump
19	532 00 76-05	Bolt, Shoulder 1/4-20 UNC
20	532 12 12-50	Spring, Compression
21	874 76 06-12	Bolt, Hex 3/8-16 x 3/4
22	873 68 06-00	Nut, Crownlock 3/8-16UNC

NOTE: All component dimensions given in U.S. inches
1 inch = 25.4mm

PUMP ASSEMBLY

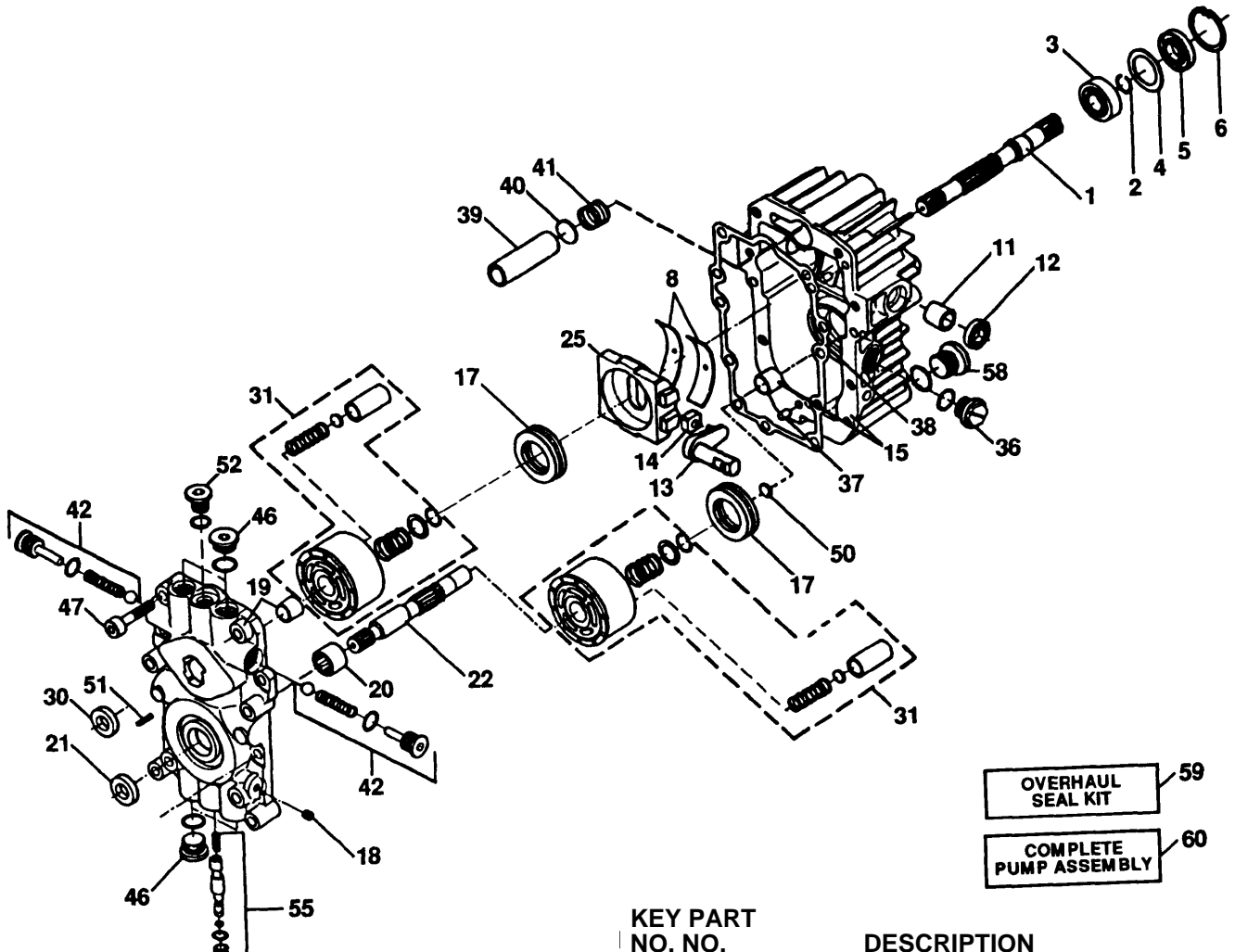

KEY PART NO. NO.

KEY PART NO. NO.	DESCRIPTION
1	532 12 27-56 Shaft, Pump
2	532 12 27-16 * Ring, Retaining
3	532 12 27-45 Bearing, Ball
4	532 12 27-15 * Spacer
5	532 12 27-00 * Seal, Lip
6	532 12 26-99 * Ring, Retaining
8	532 12 27-67 Bearing, Cradle
11	532 12 27-47 Bearing, Journal
12	532 12 27-17 * Seal, Lip
13	532 12 27-48 Arm, Trunnion
14	532 12 27-49 Guide, Slot
15	532 12 71-46 Housing Kit, Transmission
17	532 12 27-70 Bearing, Thrust, Ball
18	532 12 27-71 Plug, Pipe
19	532 12 71-47 Center Section Kit
20	532 12 27-73 Bearing, Needle
21	532 12 27-22 * Seal, Lip
22	532 12 27-50 Shaft, Motor
25	532 12 71-48 Swashplate, Variable
30	532 12 27-23 * Seal, Lip
31	532 12 71-49 Block Kit, Cylinder
36	532 12 71-51 Plug, Plastic

KEY PART NO. NO.

KEY PART NO. NO.	DESCRIPTION
37	532 12 27-86 Pin, Stainless, Headless
38	532 12 27-18 * Gasket, Center Section
39	532 12 27-31 Filter
40	532 12 27-30 Washer, Thrust
41	532 12 27-28 Spring, Helical, Compression
42	532 12 71-52 Check Valve Kit
46	532 12 27-87 Plug, Stainless, Threaded
47	532 12 27-52 Screw, Socket Head, Cap
50	532 12 27-88 Washer, Thrust
51	532 12 27-89 Pin, Spiral
52	532 12 27-54 Plug, Stainless, Threaded
55	532 12 71-53 Bypass Valve Kit
58	532 12 27-90 Plug, Stainless, Threaded
59	532 12 71-54 Overhaul Seal Kit, BDU-10
60	532 12 14-30X Pump Assembly, Complete

* STANDARD HARDWARE - PURCHASE LOCALLY

NOTE: All component dimensions given in U.S. inches
1 inch = 25.4 mm

Komponenter ingående i hydrostaten kan ej beställas från Husqvarna.

Komplett hydrostat kan beställas.

Beställ reservdelar från Sauer och Sundstrands agent.

AGRI-FABTRANSAXLE MODEL NUMBER 121431 X

J

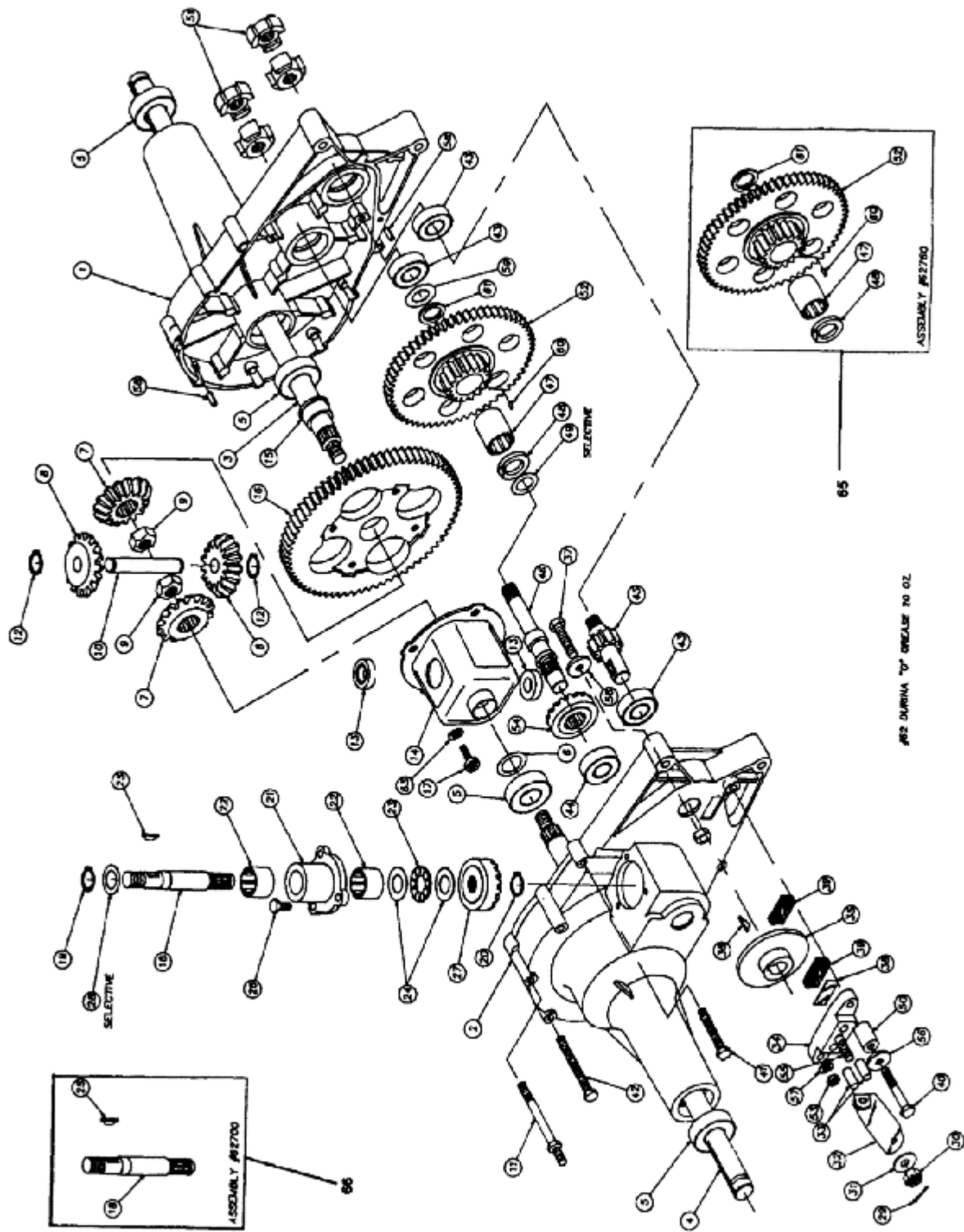

AGRI-FABTRANSAXLE MODEL NUMBER 121431 X



KEY PART NO. NO.	DESCRIPTION	KEY PART NO. NO.	DESCRIPTION
1	532 12 26-14	36	532 12 30-65
2	532 12 26-15	37	532 12 26-66
3	532 12 26-16	38	532 12 26-67
4	532 12 26-20	39	532 12 26-68
5	532 12 26-21	40	532 12 30-66
6	532 12 26-22	41	532 12 26-70
7	532 12 26-23	42	532 12 26-71
8	532 12 26-24	43	532 12 26-72
9	532 12 26-25	44	532 12 26-73
10	532 12 26-26	45	532 12 26-74
11	532 12 26-88	46	532 12 26-75
12	532 12 26-29	47	532 12 30-59
13	532 12 26-31	48	532 12 30-60
14	532 12 26-33	49	532 12 26-54
15	532 12 26-34	—	532 12 30-61
16	532 12 26-40	50	532 12 26-89
17	532 12 26-41	51	532 12 18-39
18	532 12 26-42	52	532 12 69-75
19	532 12 26-43	53	532 12 26-82
20	532 12 26-44	54	532 12 26-83
21	532 12 26-45	55	532 12 26-84
22	532 12 26-46	56	532 12 26-85
23	532 12 26-47	57	532 12 26-86
24	532 12 26-48	58	532 12 26-87
25	532 12 26-49	59	532 12 26-52
26	532 12 26-50	60	532 12 30-62
27	532 12 26-51	61	532 12 30-63
28	532 12 30-61	62	532 12 69-76
---	532 12 26-78	63	532 12 69-77
---	532 12 26-54	65	532 12 69-80
29	532 12 26-56	66	532 12 26-42
30	532 12 26-58	—	532 12 14-31
31	532 12 26-59		
32	532 12 26-60		
33	532 12 26-62		
34	532 12 26-63		
35	532 12 26-64		

NOTE: All component dimensions given in U.S. inches
1 inch = 25.4 mm

DECALS

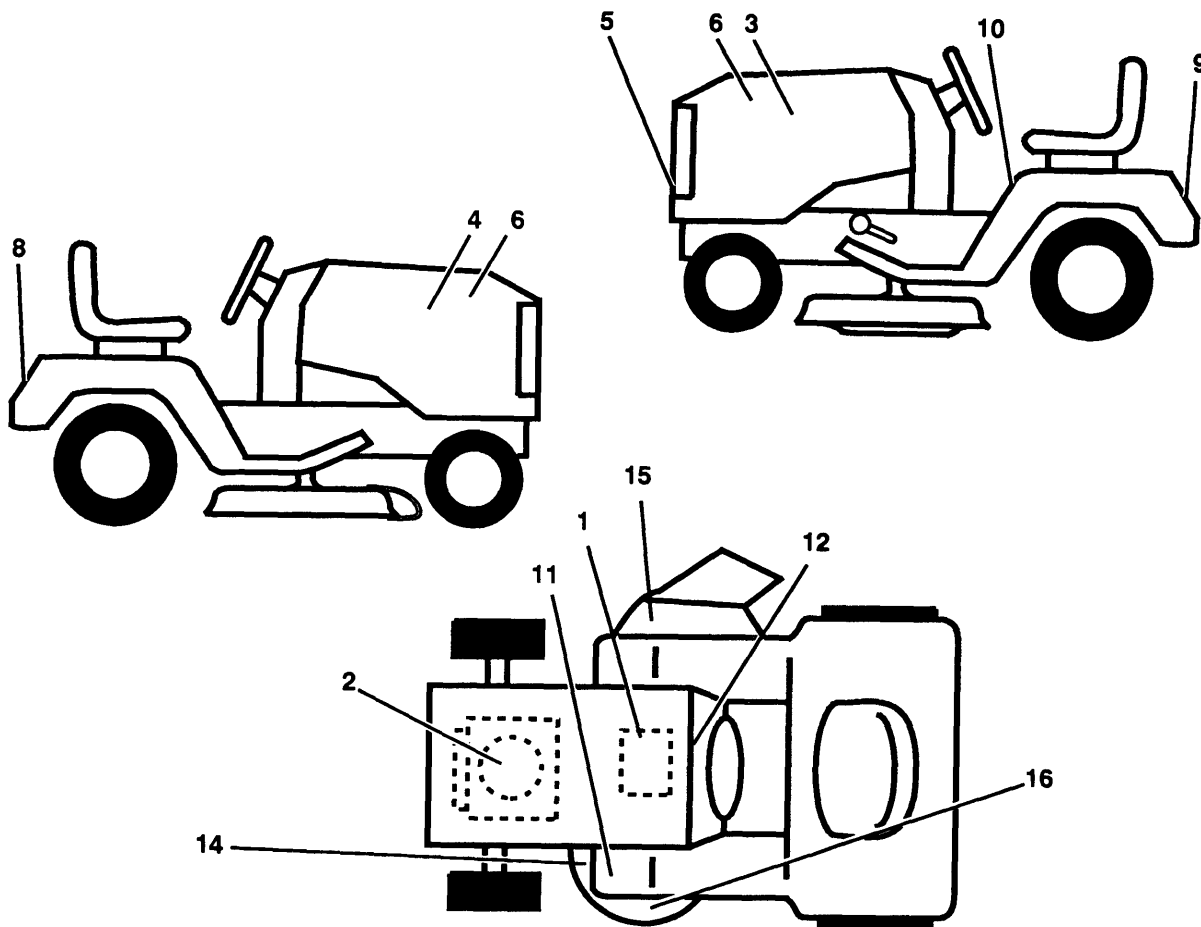

KEY NO.	PART NO.	DESCRIPTION	KEY NO.	PART NO.	DESCRIPTION
1	532 12 15-49	Decal, Caution, Battery	—	532 12 66-78	Decal, Clutch/Brake, (Spanish/Italian)
2	532 13 19-72	Decal, HP, Engine	12	532 10 88-13	Decal, Instruction, Operating, (English/French/German/Dutch)
3	532 13 15-86	Decal, Hood, L. H.	14	532 12 61-93	Decal, Warning, Deflector, (Finnish/Swedish/Norwegian/Danish)
4	532 13 15-85	Decal, Hood, R. H.	—	532 12 61-94	Decal, Warning, Deflector, (English/French/German/Dutch)
5	532 12 59-89	Decal, Logo, Grill	—	532 12 63-47	Decal, Warning, Deflector, (Spanish/Italian)
6	532 13 14-11	Decal, Model, Side Panel	15	532 12 61-91	Decal, Warning, (Swedish/Finnish/Norwegian/Danish)
8	532 13 15-82	Decal, Logo, Fender	—	532 12 61-92	Decal, Warning, (English/French/German/Dutch)
9	532 12 75-20	Decal, USA	—	532 12 63-45	Decal, Warning, (Spanish/Italian)
10	532 12 08-22	Decal, Operating, Warning, (English/French)	16	532 12 61-95	Decal, Rotating Blades, (Swedish/Finnish/Norwegian/Danish)
—	532 12 66-79	Decal, Operating, Warning, (Swedish/Danish)	—	532 12 61-96	Decal, Rotating Blades, (English/French/German/Dutch)
—	532 12 66-80	Decal, Operating, Warning, (Norwegian/Finnish)	—	532 12 63-46	Decal, Rotating Blades, (Spanish/Italian)
—	532 12 66-82	Decal, Operating, Warning, (German/Dutch)			
—	532 12 66-83	Decal, Operating, Warning, (Spanish/Italian)			
11	532 10 18-92	Decal, Clutch/Brake, (English/French/German/Dutch)			
—	532 12 66-76	Decal, Clutch/Brake, (Swedish/Finnish/Danish/Norwegian)			