

# CRT50



**1.1994**

**Spare parts**

**Ersatzteile**

**Pièces détachées**

**Reserve onderdelen**

**Repuestos**

**Reservdelar**

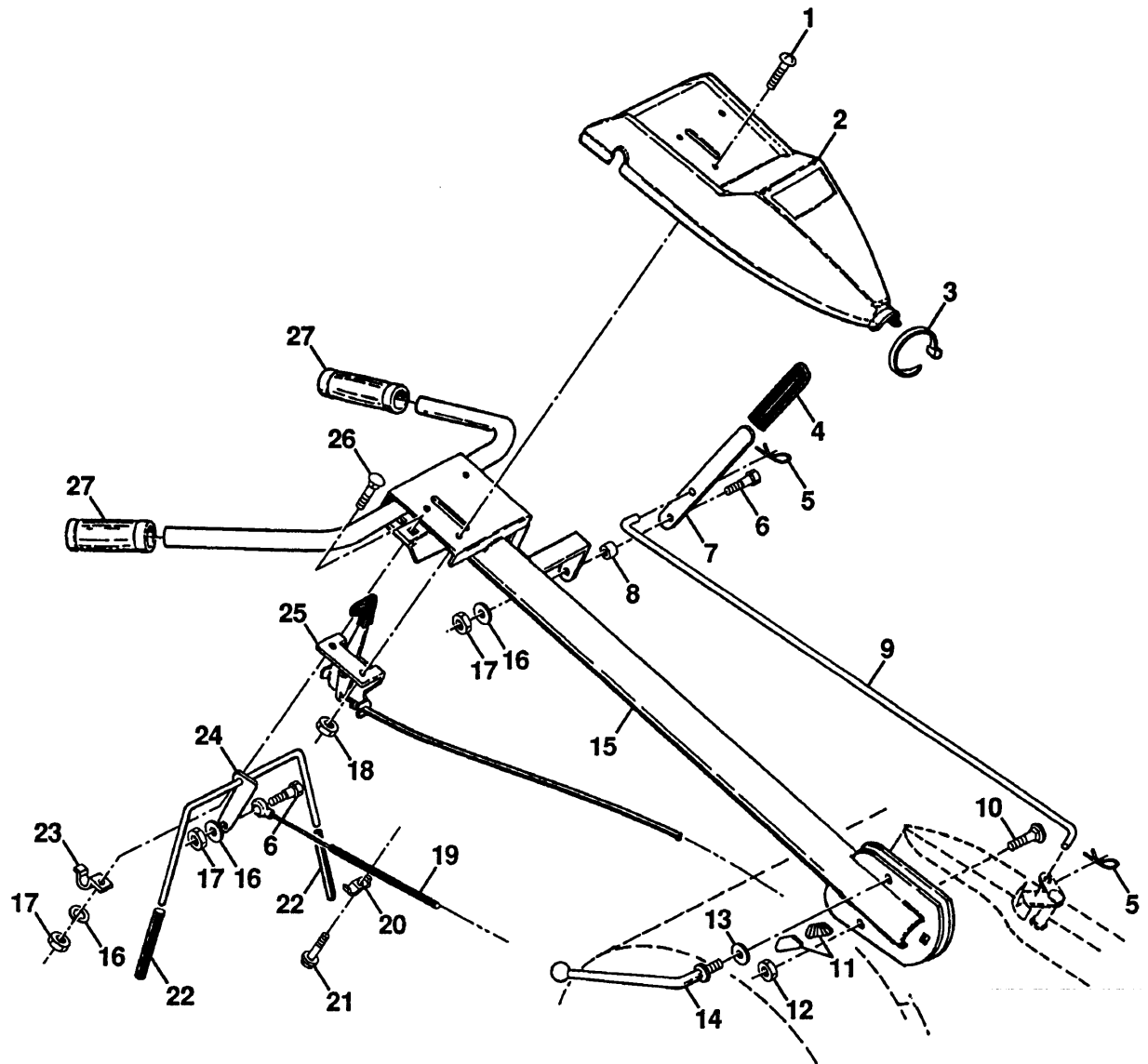

KEY NO.	PART NO.	DESCRIPTION	KEY NO.	PART NO.	DESCRIPTION
1	871 09 10-08	Screw TrussHd. #10-2i UNC x 1/2	16	810 04 04-00	Washer, Lock 1/4
2	532 12 69-56	Panel,Control	17	873 22 04-00	Nut, Hex 1/4-20
3	532 10 41-64	Tie, Cable	18	873 73 10-00	Nut,Keps #10-24 UNC
4	532 12 47-97	Grip, Handle	19	532 10 21-62	Cable, Clutch
5	532 12 47-88	Clip, Hairpin	20	532 00 94-84	Clip
6	532 08 13-28	Bolt, Shoulder	21	874 19 10-08	Screw, Hex WasherHd. Slotted #10-24 x 1/2
7	532 10 93-35	Handle, Shift	22	532 10 26-04	Grip, Bar, Control
8	532 10 93-13	Grommet, Rubber	23	532 10 27-44	Clamp, Bar, Control
9	532 10 93-37	Rod, Shift	24	532 10 52-16	Bar Assembly, Control
10	872 11 06-08	Bolt, Carriage 3/8-16x 1 Gr. 5	25	532 12 70-12	Control, Throttle
11	532 10 92-29	Lock, Handle	26	872 14 04-04	Bolt, Carriage 1/4-20 UNC x 1/2
12	873 93 06-00	Nut, Centerlock 3/8-16	27	532 14 05-28	Grip, Handle
13	819 13 16-11	Washer 13/32x 1 x 11Ga.			
14	532 10 92-28	Lever, Lock, Handle			
15	532 12 50-11	Handle			

NOTE: All component dimensions given in U.S. inches.  
1 inch = 25.4 mm

**B**

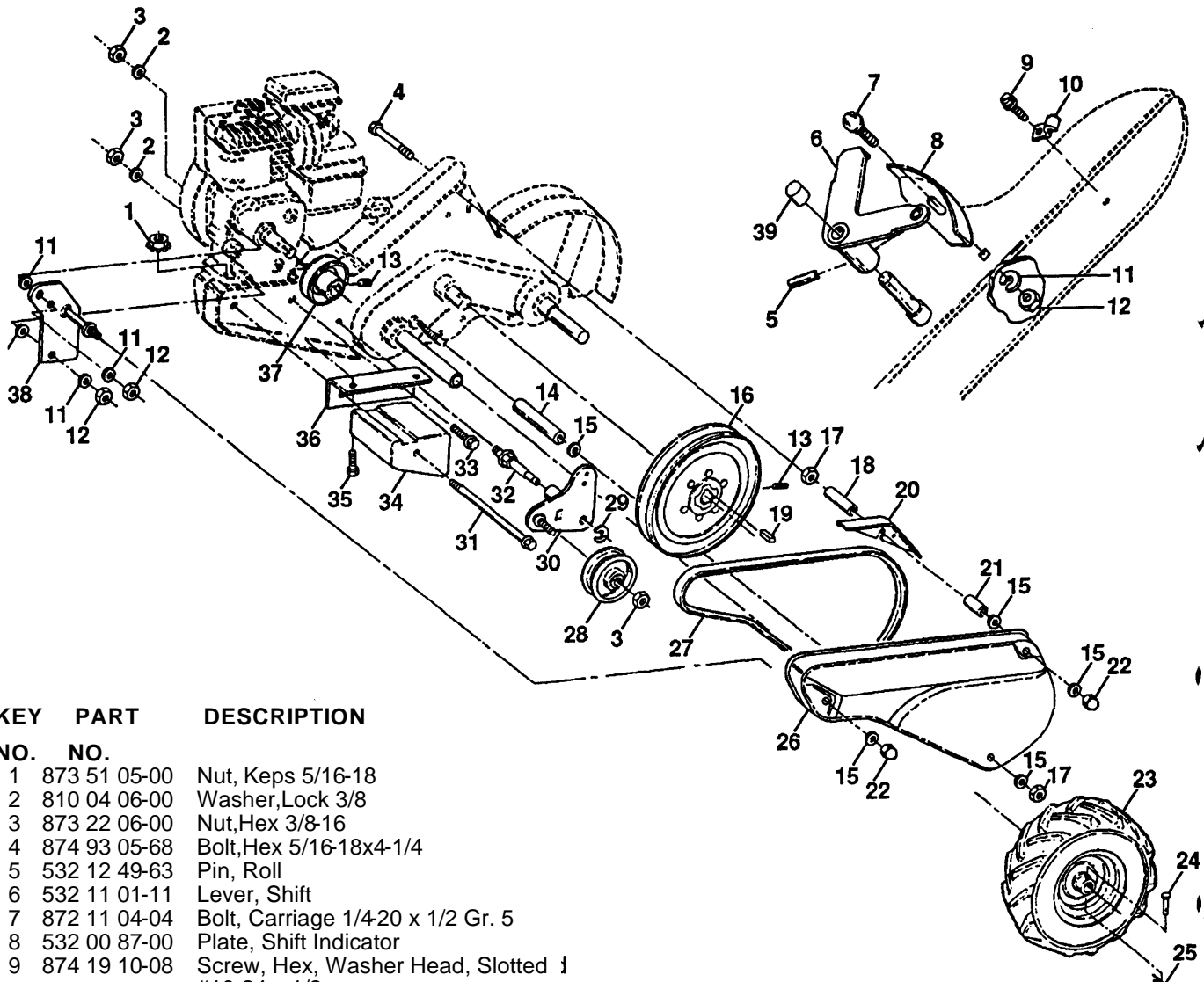

KEY NO.	PART NO.	DESCRIPTION
1	873 51 05-00	Nut, Keps 5/16-18
2	810 04 06-00	Washer, Lock 3/8
3	873 22 06-00	Nut, Hex 3/8-16
4	874 93 05-68	Bolt, Hex 5/16-18x4-1/4
5	532 12 49-63	Pin, Roll
6	532 11 01-11	Lever, Shift
7	872 11 04-04	Bolt, Carriage 1/4-20 x 1/2 Gr. 5
8	532 00 87-00	Plate, Shift Indicator
9	874 19 10-08	Screw, Hex, Washer Head, Slotted J #10-24 x 1/2
10	532 00 94-84	Clip
11	810 04 04-00	Washer, Lock 1/4
12	873 22 04-00	Nut, Hex 1/4-20
13	823 23 05-06	Screw, Set, Hex 5/16-18 x 3/8
14	532 12 09-38	Spacer, Split 0.327 x 0.42 x 2.68
15	819 11 11-16	Washer 11/32 x 11/16 x 16Ga.
16	532 10 04-73	Sheave, Transmission
17	873 22 05-00	Nut, Hex 5/16-18
18	532 11 06-51	Spacer, Split 0.327 x 0.42 x 1.75
19	532 00 26-49	Key, Square 3/16x1-1/8
20	532 11 06-53	Guard, Pinch Point
21	532 13 16-91	Spacer, Split 0.327 x 0.42 x 1.627
22	873 68 05-00	Nut, 5/16-18
23	532 10 21-90	Tire
	532 12 42-58	Rim
	532 12 47-18	Tire Valve
24	532 12 68-75	Rivet, Drilled
25	532 12 47-88	Clip, Hairpin
26	532 12 53-39	Guard, Belt

KEY NO.	PART NO.	DESCRIPTION
27	532 13 26-72	Belt, V
28	532 10 46-79	Pulley, Idler
29	812 00 00-32	Ring, Klip
30	532 10 56-11	Bracket, Idler
31	532 10 23-84	Bolt, Hex 5/16-16 x 12
32	532 10 21-41	Shaft, Idler Arm
33	874 76 06-16	Bolt, Hex 3/8-16x1
34	532 10 23-83	Counterweight, L. H.
35	874 76 05-24	Bolt, Hex 5/16-18 x 1-1/2
36	532 10 23-31	Bracket, Reinforcement, L. H.
37	532 13 08-16	Sheave, Engine
38	532 13 15-58	Bracket, Guard Belt
39	532 14 00-62	Cap Plunger

NOTE: All component dimensions given in U.S. inches.  
1 inch = 25.4 mm

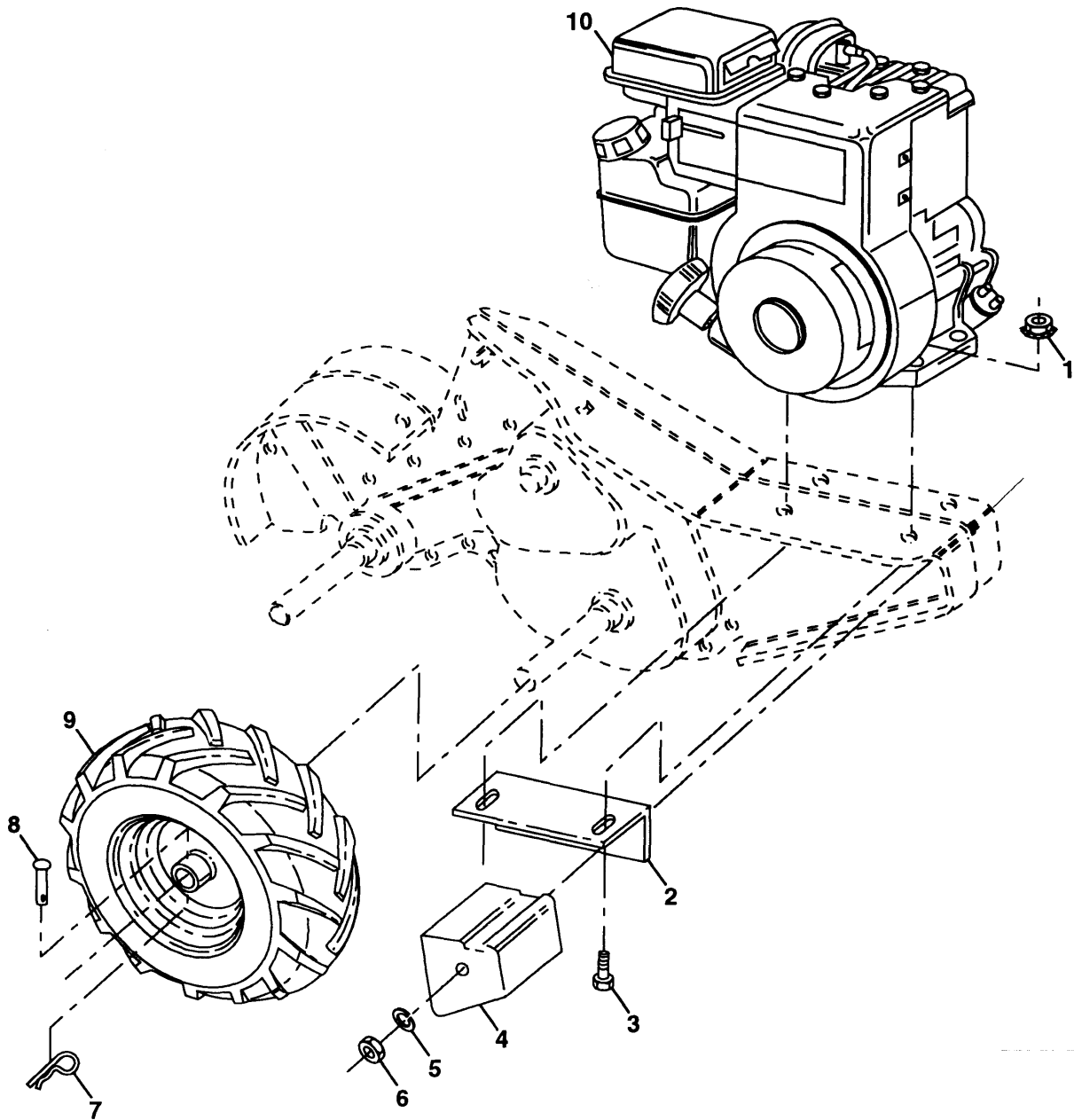

KEY PART NO.	NO.	DESCRIPTION
1	873 51 05-00	Nut, Keps 5/16-18
2	532 10 23-32	Bracket, Reinforcement
3	874 76 05-24	Bolt, Hex 5/16-18x1-1/2
4	532 10 21-73	Counter Weight, R.H.
5	810 04 06-00	Washer, Lock 3/8
6	873 22 06-00	Nut, Hex 3/8-16
7	532 12 47-88	Clip, Hairpin
8	532 12 68-75	Rivet, Drilled

KEY PART NO.	NO.	DESCRIPTION
9	532 10 21-90	Tire
	532 12 42-58	Rim
	532 12 47-18	Tire Valve
10	-----	Engine, Briggs & Stratton Model No.135202

NOTE: All component dimensions given in U.S.inches.  
1 inch = 25.4 mm

# D

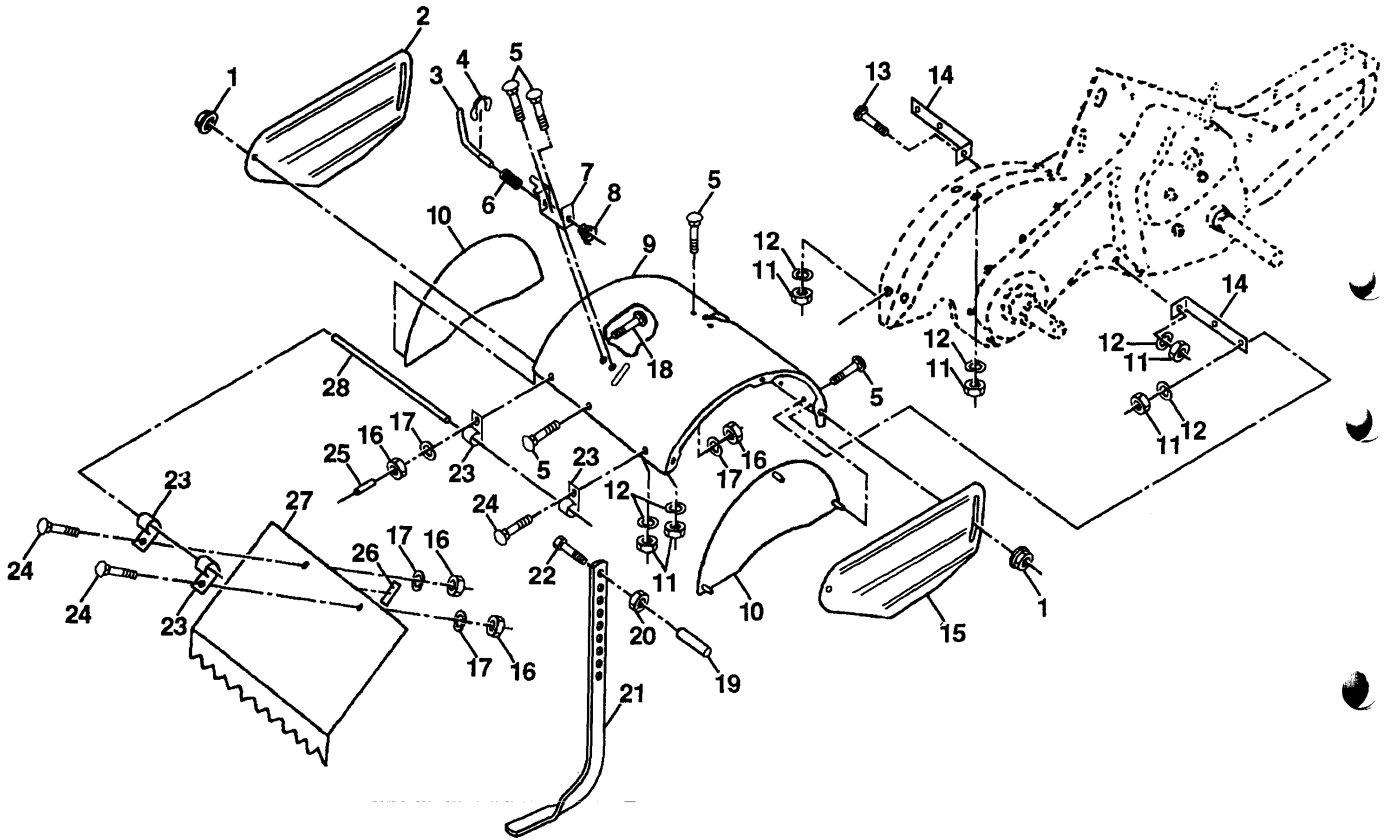

KEY NO.	PART NO.	DESCRIPTION
1	898 00 01-29	Nut, Flange 5/16-18
2	532 12 50-12	Shield, Side, Outer L. H.
3	532 00 83-93	Pin, Stake, Depth
4	812 00 00-36	Ring, Klip
5	872 14 05-06	Bolt, Carriage 5/16-18x3/4 Gr 5
6	532 00 83-94	Spring
7	532 00 83-92	Bracket, Latch
8	532 10 92-30	Spring, Depth Stake
9	532 13 88-63	Shield Tine
10	532 12 50-13	Shield Side
11	873 22 05-00	Nut, Hex 5/16-18
12	810 04 05-00	Washer, Lock 5/16
13	872 11 05-10	Bolt, Carriage 5/16-18 x 1 - 1/4
14	532 12 43-43	Bracket, Shield Tine
15	532 12 50-15	Shield, Side, Outer R.H.
16	873 22 04-00	Nut, Hex 1/4

KEY NO.	PART NO.	DESCRIPTION
17	810 04 04-00	Washer, Lock 1/4 L, 6
18	872 04 04-10	Bolt, Carriage 1/4-20 x 1 - 1/4 Gr.
19	532 10 27-01	Grip
20	873 22 06-00	Nut, Hex 3/8-16
21	532 10 21-56	Stake, Depth
22	874 93 06-32	Bolt, Hex 3/8-16x2
23	532 00 44-40	Hinge
24	872 14 04-04	Bolt, Carriage 1/4-20 x 1/2 Gr. 5
25	532 12 47-17	Cap, Vinyl
26	532 10 92-27	Pad, Idler
27	532 12 50-16	Shield, Leveling
28	532 12 05-88	Pin, Hinge

NOTE. All component dimensions given in U.S. inches.  
1 inch = 25.4 mm

**E**

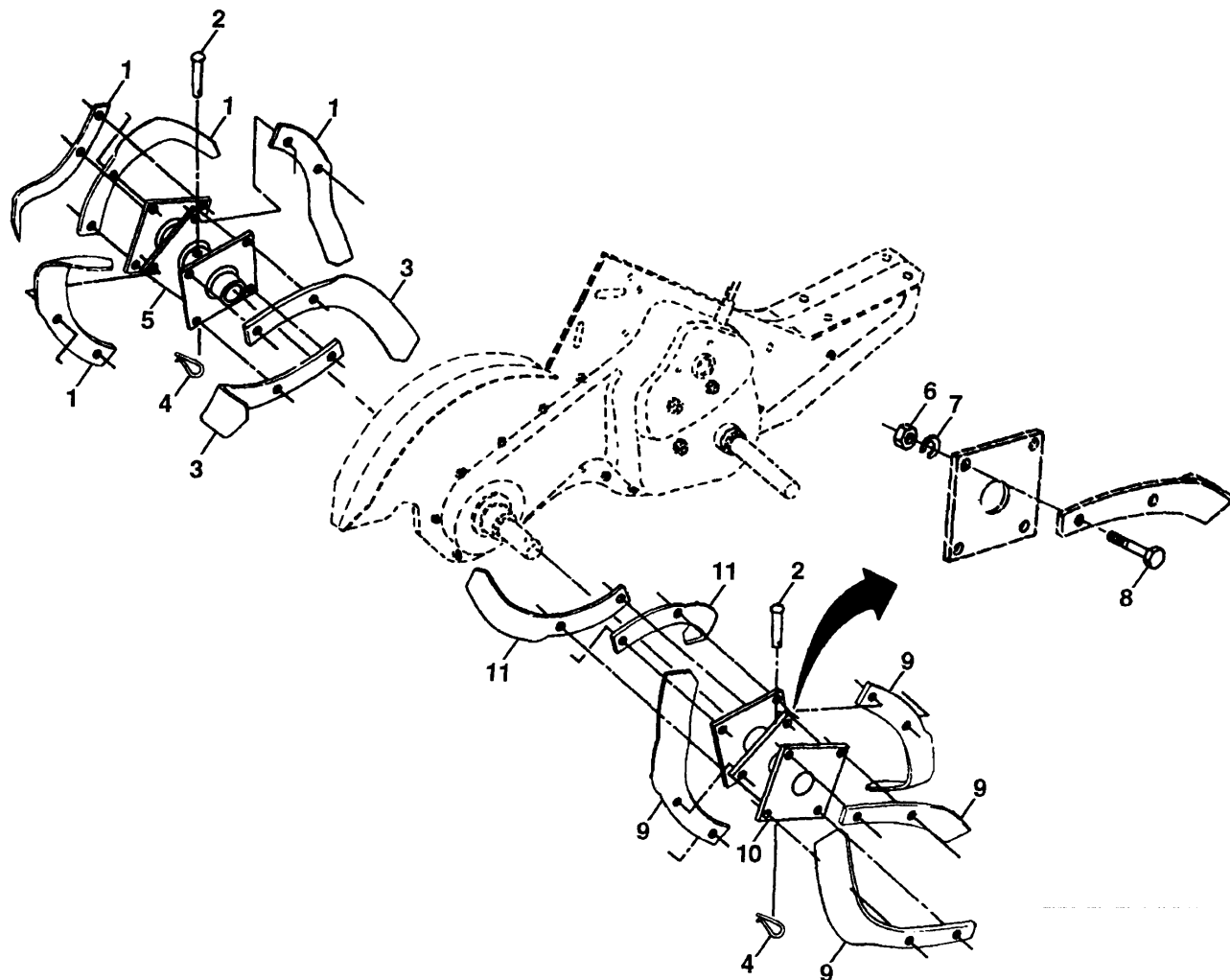

KEY NO.	PART NO.	DESCRIPTION
1	532 00 65-55	Tine, Outer, L.H.
2	532 13 26-73	Clevis Pin
3	532 00 65-54	Tine, Inner, L.H.
4	532 12 46-60	Clip, Hairpin
5	532 13 27-27	Assembly, Hub and Plate, L.H.
6	873 61 06-00	Nut, Hex 3/8-24
7	810 04 06-00	Washer, Lock 3/8

KEY NO.	PART NO.	DESCRIPTION
8	874 61 06-16	Bolt, Hex 3/8-24x 1
9	532 00 65-54	Tine, Outer, R.H.
10	532 13 27-28	Assembly, Hub and Plate, R.H.
11	532 00 65-55	Tine, Inner, R.H.

NOTE: All component dimensions given in U.S. inches.  
1 inch = 25.4 mm

F

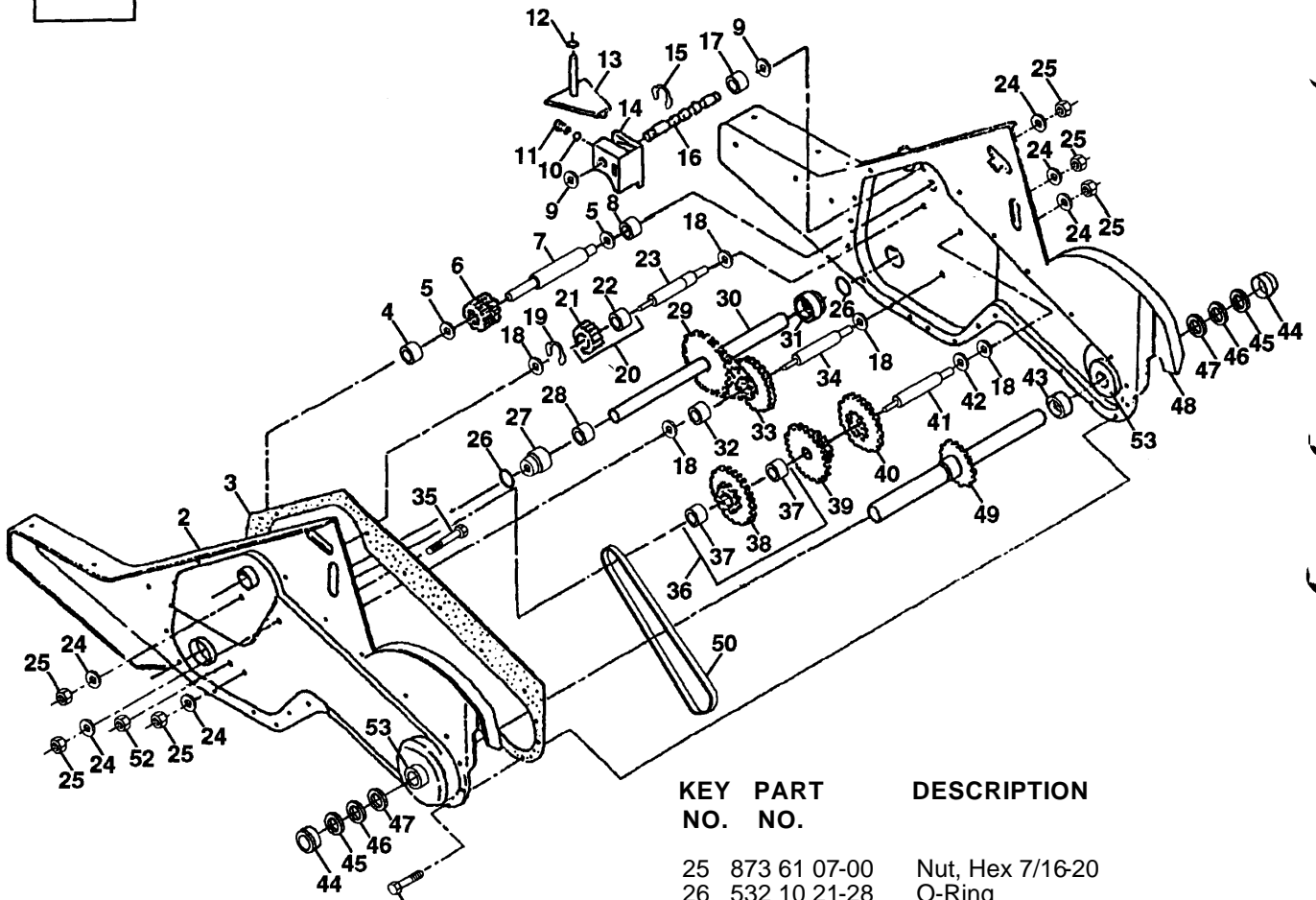

KEY PART NO.	PART NO.	DESCRIPTION
1	532 14 05-24	Transmission Assembly (Includes Key Nos. 2-53)
2	532 13 95-44	Gearcase, L.H. w/Bearing (Includes Key No. 4)
3	532 10 62-11	Gasket, Gearcase
4	532 00 50-20	Bearing, Needle
5	532 00 13-70	Washer, Thrust 5/8 x 1.10 x 1/32
6	532 10 21-13	Pinion, Input
7	532 10 21-10	Shaft, Input
8	532 12 47-92	Bearing, Needle
9	532 10 21-36	Washer, Seal
10	532 12 46-97	Ball, Steel
11	532 10 03-71	Spring, Shift, Fork
12	532 10 61-60	O-Ring
13	532 13 99-68	Arm, Shift
14	532 00 83-53	Fork, Shift
15	812 00 00-39	Ring, Klip
16	532 10 21-09	Shaft, Shift
17	532 10 41-59	Spacer, Split
18	532 00 43-58	Washer
19	812 00 00-40	Ring, Klip
20	532 10 21-14	Gear, Assembly, Reverse Idler (Includes Key Nos. 21 and 22)
21	532 10 21-15	Gear, Reverse Idler
22	532 00 68-03	Bearing, Needle
23	532 10 21-11	Shaft, Reverse Idler
24	810 04 07-00	Washer, Lock 7/16

KEY PART NO.	PART NO.	DESCRIPTION
25	873 61 07-00	Nut, Hex 7/16-20
26	532 10 21-28	O-Ring
27	532 10 21-00	Bearing, Shaft, Ground Drive
28	532 10 63-90	Spacer 0.765 x 1.125 x 1.23
29	532 10 21-34	Chain #35-50 Pitch
30	532 10 92-04	Ground Shaft Assembly
31	532 10 21-06	Bearing, Shaft, Ground Drive
32	532 10 63-88	Spacer 0.70x1.00x1.150
33	532 10 21-21	Sprocket and Gear Assembly
34	532 10 21-12	Shaft, Reduction (2nd)
35	532 10 21-01	Screw, Whiz, Lock 5/16-18 x 3-1/2
36	532 13 73-00	Sprocket Assembly w/Bearing (Includes Key Nos. 37 and 38)
37	532 12 47-91	Bearing, Needle
38	532 13 73-01	Sprocket, Tine
39	532 10 53-45	Gear, Cluster, Red 1st & 2nd
40	532 10 53-46	Gear, Reverse
41	532 00 83-58	Shaft, Reduction (1st)
42	532 00 42-20	Washer, Thrust
43	532 10 61-46	Spacer 1.01 x 1.75 x 0.760
44	532 00 96-72	Cup, Formed
45	532 10 21-44	Ring, Spiral
46	532 14 05-76	Seal, Ring, Rubber
47	532 12 46-98	Seal, Oil
48	532 13 95-46	Gearcase, R.H. w/Bearing (Includes Key No. 8)
49	532 13 26-88	Shaft, Tine
50	532 10 61-47	Chain, Roller #50-50 Pitch
51	817 58 04-08	Screw 1/4-20 x 1/2
52	873 22 05-00	Nut, Hex 5/16-18
53	532 12 22-04	Kit Bearing
--	532 00 60-66	Grease, Plastilube #1

NOTE: All component dimensions given in U.S. inches.  
1 inch = 25.4 mm

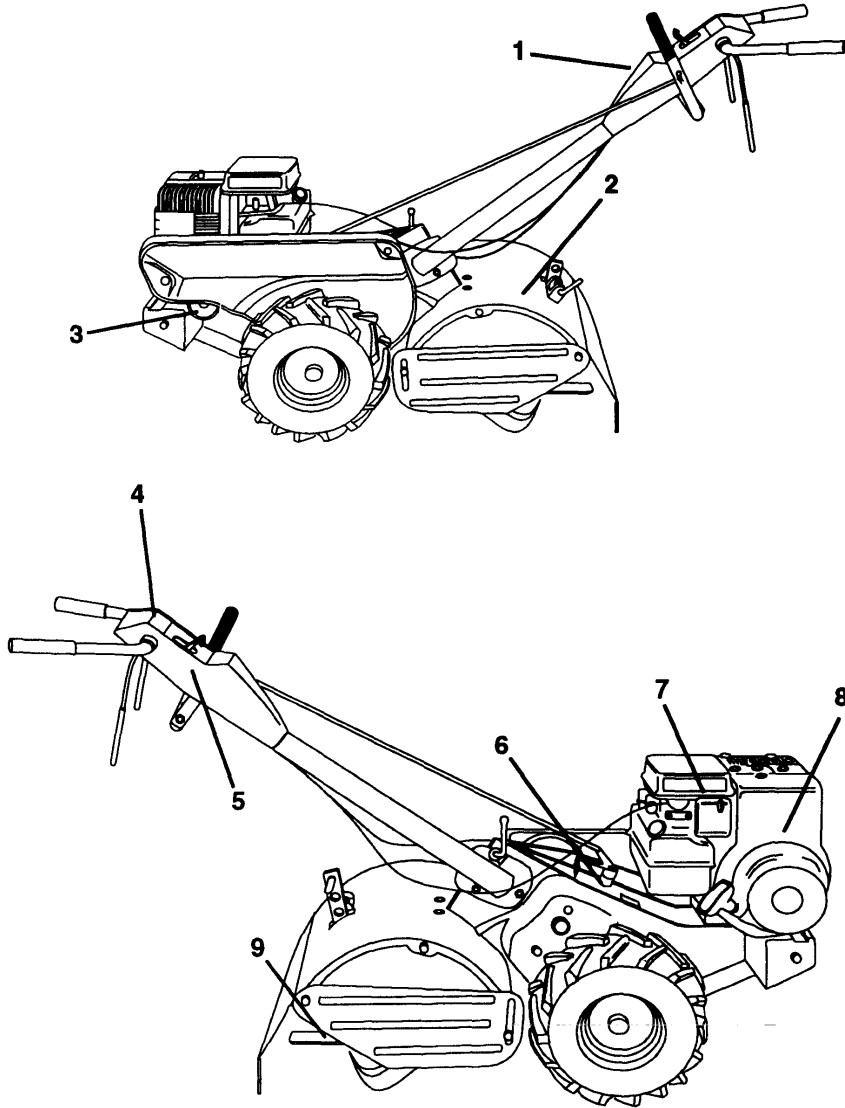

KEY PART NO.	PART NO.	DESCRIPTION
1	532 13 73-81	Decal, Logo
2	532 12 42-63	Decal, Logo
3	532 13 73-82	Decal, Logo
4	532 13 69-42	Decal, Instruction, Tilling
5	532 11 06-14	Decal, Hand Placement
6	532 10 43-23	Decal, Shift Indicator
7	532 11 06-12	Decal, Caution
8	532 12 15-43	Decal, Briggs & Stratton
9	532 12 00-76	Decal, Warning, Rotating Tines



MODEL NUMBER CRT50

PART NUMBER	SQUARE	NOTE	PART NUMBER	SQUARE	NOTE	PART NUMBER	SQUARE	NOTE	PART NUMBER	SQUARE
532 00 13-70	F	N	532 11 01-11	B	N	872 14 04-04	AD			
532 00 26-49	B		532 11 06-12	G	N	872 14 05-06	D			
532 00 42-20	F	N	532 11 06-14	G	N	873 22 04-00	ABD			
532 00 43-58	F		532 11 06-51	B	N	873 22 05-00	BDF			
532 00 44-40	D	N	532 11 06-53	B	N	873 22 06-00	BCD			
532 00 50-20	F	N	532 12 00-76	G	N	873 51 05-00	BC			
532 00 60-66	F	N	532 12 05-88	D	N	873 61 06-00	D			
532 00 65-54	D	N	532 12 09-38	B	N	873 61 07-00	F			
532 00 65-55	E	N	532 12 15-43	G	N	873 68 05-00	B			
532 00 68-03	F	N	532 12 22-04	F	N	873 73 10-00	A			
532 00 83-53	F	N	532 12 42-58	BC	N	873 93 06-00	A			
532 00 83-58	F	N	532 12 42-63	G	N	874 19 10-08	AB			
532 00 83-92	D	N	532 12 43-43	D	N	874 61 06-16	D			
532 00 83-93	D	N	532 12 46-60	D	N	874 76 05-24	BC			
532 00 83-94	D	N	532 12 46-97	F	N	874 76 06-16	B			
532 00 87-00	B	N	532 12 46-98	F	N	874 93 05-68	B			
532 00 94-84	AB	N	532 12 47-17	D	N	874 93 06-32	D			
532 00 96-72	F		532 12 47-18	BC	N	898 00 01-29	D			
532 08 13-28	A	N	532 12 47-88	ABC						
532 10 03-71	F	N	532 12 47-91	F	N					
532 10 04-73	B	N	532 12 47-92	F	N					
532 10 21-00	F	N	532 12 47-97	A	N					
532 10 21-01	F	N	532 12 49-63	B	N					
532 10 21-06	F	N	532 12 50-11	A	N					
532 10 21-09	F	N	532 12 50-12	D	N					
532 10 21-10	F	N	532 12 50-13	D	N					
532 10 21-11	F	N	532 12 50-15	D	N					
532 10 21-12	F	N	532 12 50-16	D	N					
532 10 21-13	F	N	532 12 53-39	B	N					
532 10 21-14	F	N	532 12 68-75	BC	N					
532 10 21-15	F	N	532 12 69-56	A	N					
532 10 21-21	F	N	532 12 70-12	A	N					
532 10 21-28	F	N	532 13 08-16	B	N					
532 10 21-34	F	N	532 13 15-58	B	N					
532 10 21-36	F	N	532 13 16-91	B	N					
532 10 21-41	B	N	532 13 26-72	B	N					
532 10 21-44	F	N	532 13 26-73	E	N					
532 10 21-56	D	N	532 13 26-88	F	N					
532 10 21-62	A	N	532 13 27-27	D	N					
532 10 21-73	C	N	532 13 27-28	D	N					
532 10 21-90	BC	N	532 13 69-42	G	N					
532 10 23-31	B	N	532 13 73-00	F	N					
532 10 23-32	C	N	532 13 73-01	F	N					
532 10 23-83	B	N	532 13 73-81	G	N					
532 10 23-84	B	N	532 13 73-82	G	N					
532 10 26-04	A	N	532 13 88-63	D	N					
532 10 27-01	D	N	532 13 95-44	F	N					
532 10 27-44	A	N	532 13 95-46	F	N					
532 10 41-59	F	N	532 13 99-68	F	N					
532 10 41-64	A	N	532 14 00-62	B	N					
532 10 43-23	G	N	532 14 05-24	F	N					
532 10 46-79	B	N	532 14 05-28	A	N					
532 10 52-16	A	N	532 14 05-76	F	N					
532 10 53-45	F	N	810 04 04-00	ABD						
532 10 53-46	F	N	810 04 05-00	D						
532 10 56-11	B		810 04 06-00	BCD						
532 10 61-46	F	N	810 04 07-00	F	N					
532 10 61-47	F	N	812 00 00-32	B						
532 10 61-60	F	N	812 00 00-36	D						
532 10 62-11	F	N	812 00 00-39	F						
532 10 63-88	F	N	812 00 00-40	F						
532 10 63-90	F	N	817 58 04-08	F	N					
532 10 92-04	F	N	819 11 11-16	B						
532 10 92-27	D	N	819 13 16-11	A						
532 10 92-28	A	N	823 23 05-06	B	N					
532 10 92-29	A	N	871 09 10-08	A						
532 10 92-30	D	N	872 04 04-10	D						
532 10 93-13	A	N	872 11 04-04	B						
532 10 93-35	A	N	872 11 05-10	D	N					
532 10 93-37	A	N	872 11 06-08	A						

N=New part  
 Neues teil  
 Nouvelle piece  
 Nueva pieza  
 Nv detali