

IPL-GT200

954 00 20-12A

TRACTOR - MODEL NUMBER GT200 (954002012A)

SCHEMATIC

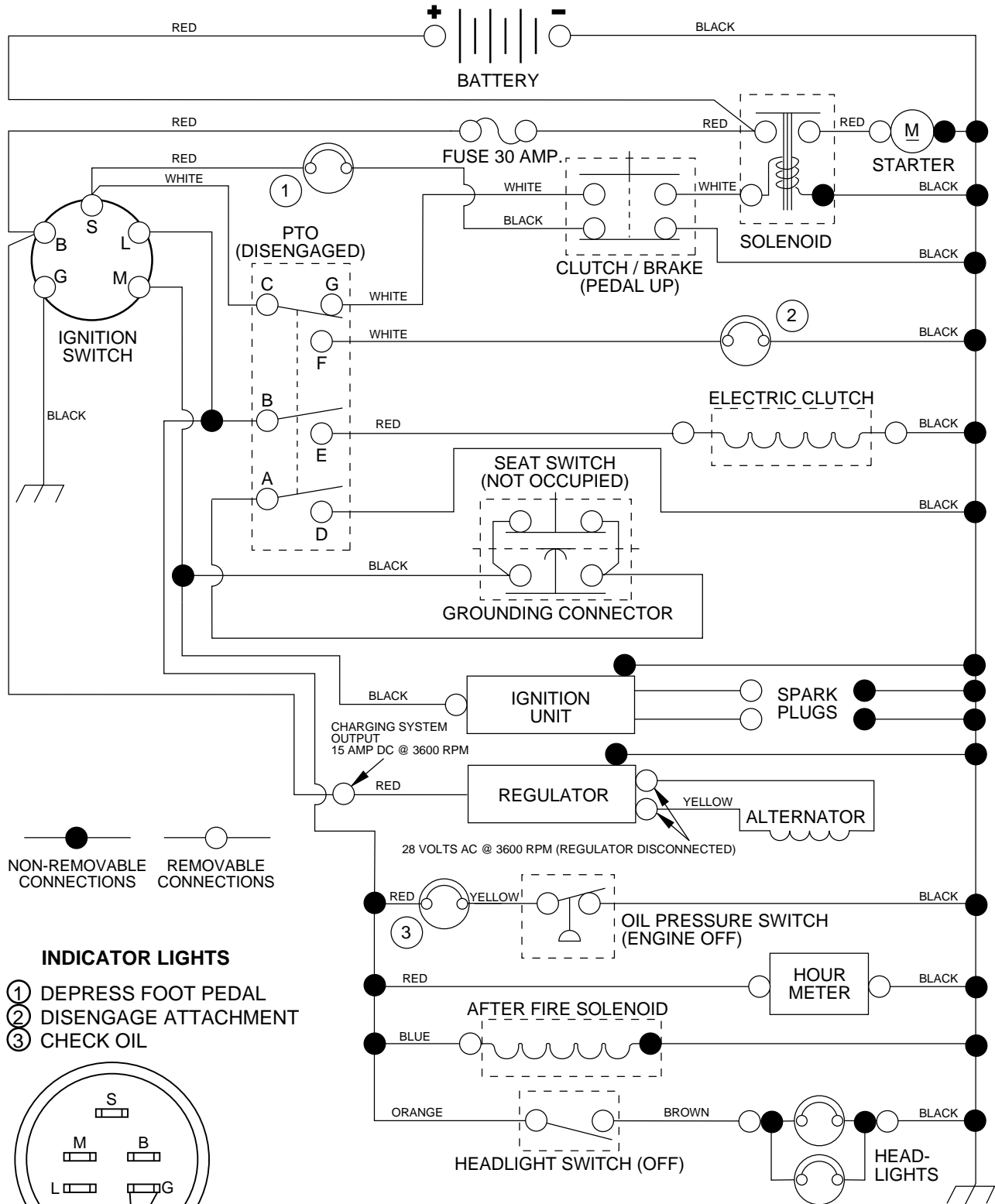

NON-REMOVABLE CONNECTIONS (solid black dot)
REMOVABLE CONNECTIONS (open circle)

INDICATOR LIGHTS

- ① DEPRESS FOOT PEDAL
- ② DISENGAGE ATTACHMENT
- ③ CHECK OIL

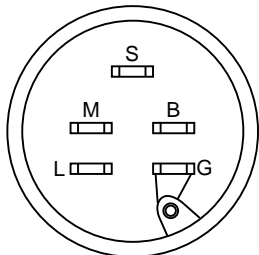

IGNITION SWITCH

POSITION	CIRCUIT
OFF	M + G
ON	B + L
START	B + S + L

WIRING INSULATED CLIPS

NOTE: IF WIRING INSULATED CLIPS WERE REMOVED FOR SERVICING OF UNIT, THEY SHOULD BE REPLACED TO PROPERLY SECURE YOUR WIRING.

PTO SWITCH

POSITION	CIRCUIT
OFF	C + G
ON	C + F, B + E, A + D

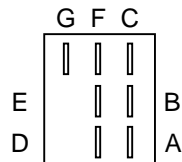

REPAIR PARTS

TRACTOR - MODEL NUMBER GT200 (954002012A)

DECALS

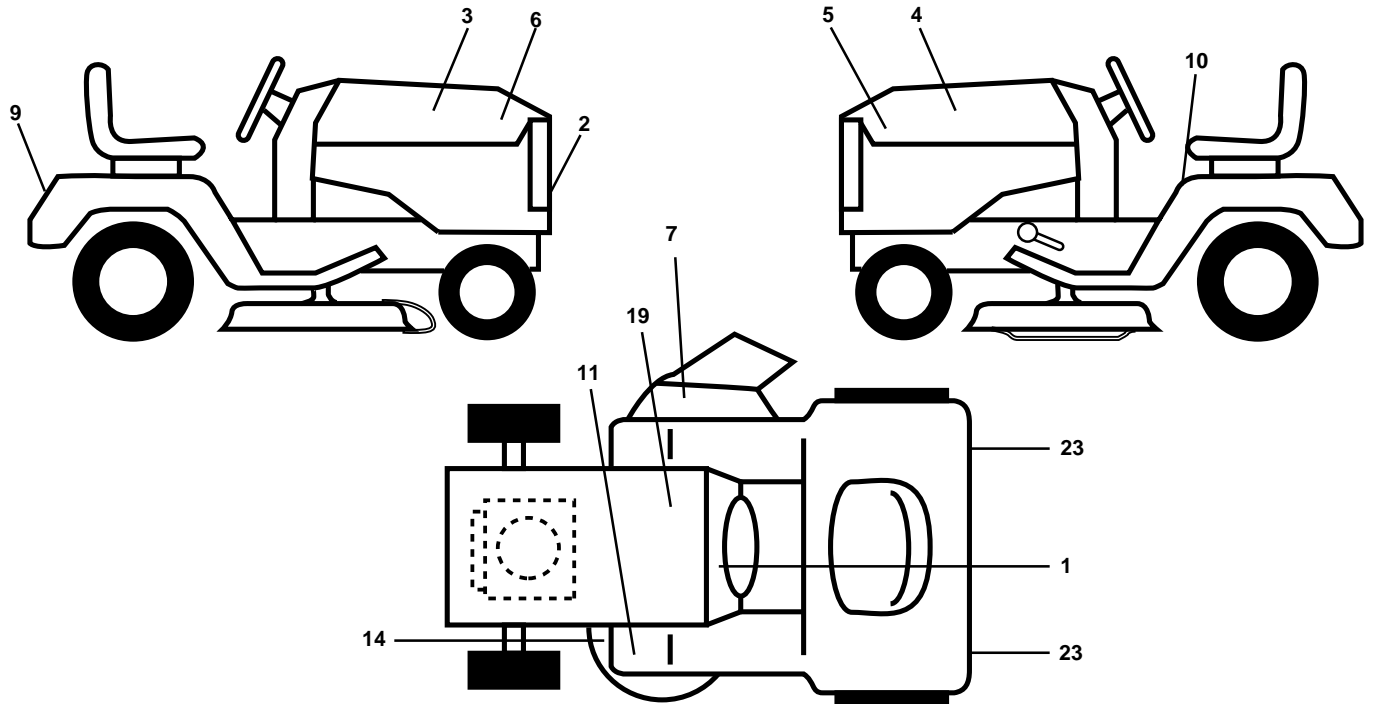

KEY NO.	PART NO.	DESCRIPTION
1	532138956	Decal, Operating Instruction
2	532125989	Decal, Grille Husqvarna "H" Logo
3	532140728	Decal, Hood, RH
4	532140729	Decal, Hood, LH
5	532140856	Decal, Insert Hood LH GT200 6Sp
6	532140857	Decal, Insert Hood RH GT200 6Sp
7	532137259	Decal, Warning Multi-Language
9	532131582	Decal, Fender
10	532133795	Decal, Caution
11	532101892	Decal, Clutch/Brake
14	532139346	Decal, V-Belt Schematic
19	532145005	Decal, Battery

KEY NO.	PART NO.	DESCRIPTION
23	532106202	Reflector, Taillight
--	532150187	Manual, Owner's (English)
--	532150188	Manual, Owner's (French)
--	532138311	Decal, Handle Lift Height Adjust (Lift Handle)
--	532145246	Pad Footrest Rbr Sq Generic 95
--	532145247	Fastener Pop-In Footrest (8 per)
Accessories not included with tractor:		
--	SH10	Sleeve Hitch
--	TA128	Tire Chains
--	GBD48	48" Snow Blade
--	TA321	#55 Wheel Weights
--	EA20	Electric Assist Kit
--	GSB42	42" Snow Blower

WHEELS & TIRES

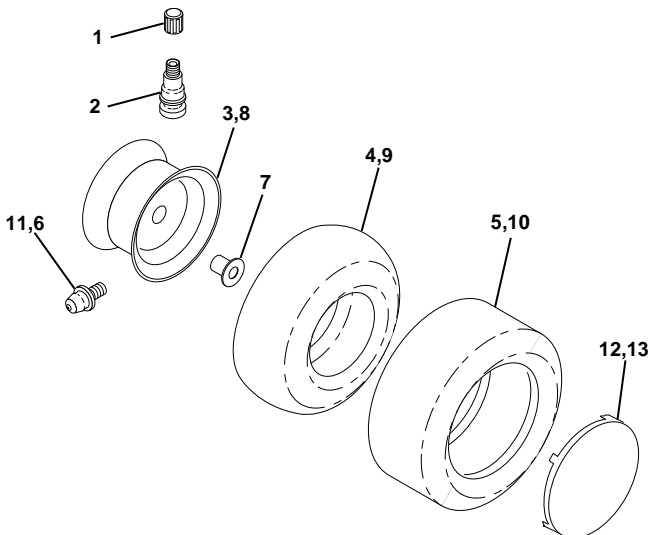

KEY NO.	PART NO.	DESCRIPTION
1	532059192	Cap, Valve, Tire
2	532065139	Stem, Valve
3	532141624	Rim Assembly, Front
4	532008134	Tube, Front (Service Item Only)
5	532106230	Tire, Front
6	532124957	Fitting, Grease
7	532124959	Bearing, Flange (Front Wheel Only)
8	532141625	Rim Assembly, Rear
9	532007154	Tube, Rear (Service Item Only)
10	532105588	Tire, Rear
11	532124860	Fitting, Grease
12	532124578	Cover Wheel 8" White
13	532124579	Cover, Wheel 12" White
--	532144344	Sealant, Tire (10 oz. Tube)

NOTE: All component dimensions given in U.S. inches
1 inch = 25.4 mm

REPAIR PARTS

TRACTOR - MODEL NUMBER GT200 (954002012A)

ELECTRICAL

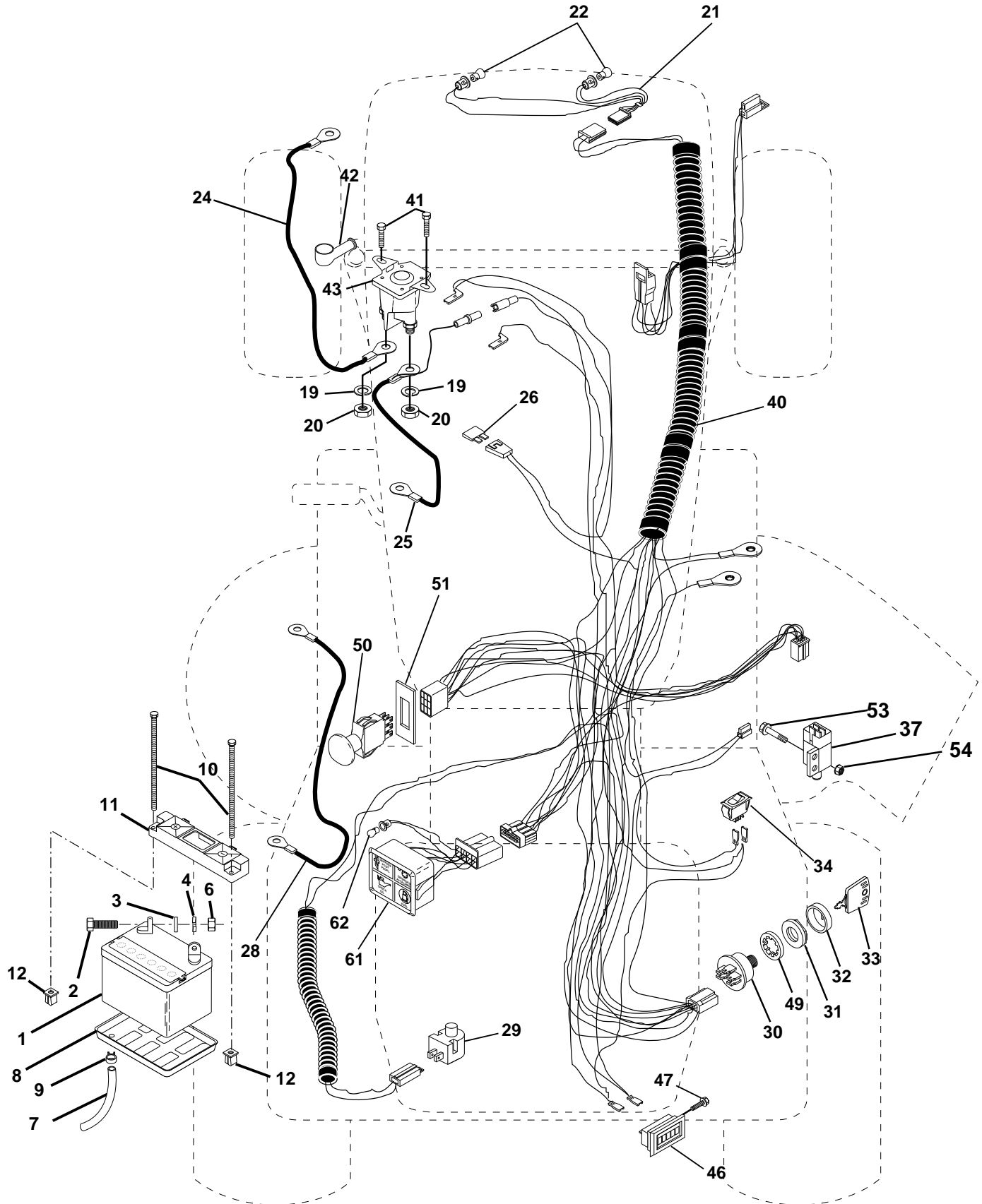

REPAIR PARTS

TRACTOR - MODEL NUMBER GT200 (954002012A)

ELECTRICAL

KEY NO.	PART NO.	DESCRIPTION
1	532144927	Battery
2	874760412	Bolt Hex Head 1/4-20 x 3/4
3	810040400	Washer, Lock 1/4
4	819091016	Washer 9/32 x 5/8 x 16 Ga
6	873220400	Nut Fin Hex 1/4-20
7	532007697	Tube, Plastic
8	532124886	Tray, Battery
9	532109596	Clamp, Hose
10	532145211	Bolt, Battery Frt. 1/4-20 x 7-1/2 Zinc
11	532145209	Holddown Battery Dash Mount
12	532145769	Nut Push Nylon 1/4" Battery Frt.
19	810090400	Washer, Lock 1/4
20	873350400	Nut, Jam Hex 1/4-20
21	532136850	Harness, Socket, Light w/4152
22	532004152	Bulb, Light
24	532004014	Cable, Starter
25	532146686	Cable, Battery Red 4 Ga. w/16 Wire
26	532108824	Fuse
28	532006408	Cable, Ground
29	532121305	Switch, Plunger
30	532144921	Switch, Ign
31	532140400	Nut, Ignition Switch
32	532141226	Cover, Switch Key
33	532140401	Key
34	532110712	Switch, Light
37	532109553	Intlk Switch
40	532147341	Harness, Ign.
41	817720408	Screw 1/4-20 x 1/2
42	532131563	Cover, Terminal Red
43	532145673	Solenoid
46	532110940	Meter, Hour
47	817011008	Screw #10-24 x 1/2
49	811151000	Washer, Lock Internal Tooth 5/8
50	532140404	Switch, PTO
51	532140405	Ring, Retainer, PTO
61	532138101	Light Pkg Asm
62	532110143	Bulb, Light Pkg.

NOTE: All component dimensions given in U.S. inches
1 inch = 25.4 mm

REPAIR PARTS

TRACTOR - MODEL NUMBER GT200 (954002012A)

CHASSIS AND ENCLOSURES

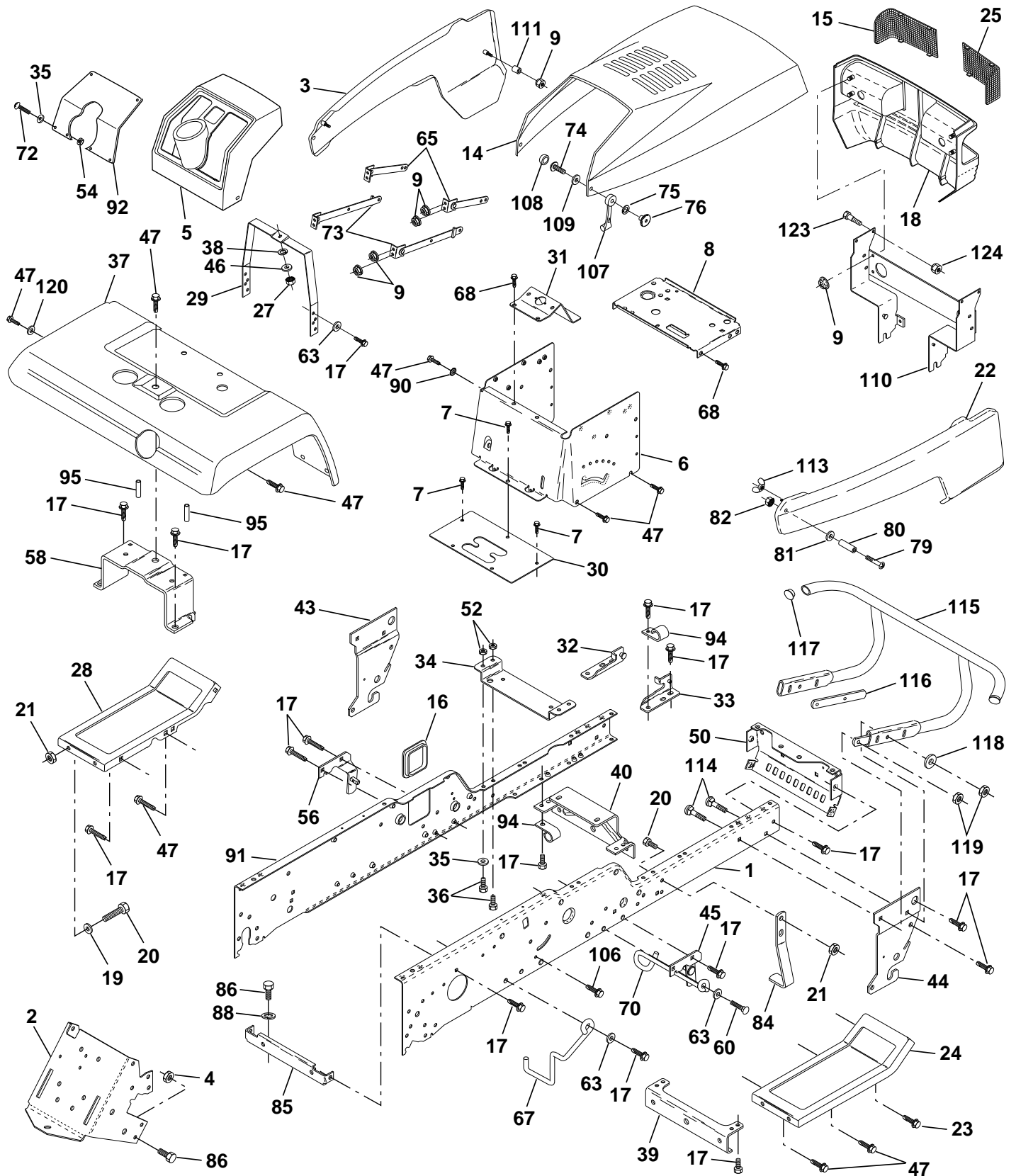

REPAIR PARTS

TRACTOR - MODEL NUMBER GT200 (954002012A)

CHASSIS AND ENCLOSURES

KEY NO.	PART NO.	DESCRIPTION	KEY NO.	PART NO.	DESCRIPTION
1	532144737	Rail, Frame RH	58	532137113	Bracket Asm., Fender
2	532140506	Drawbar, Gt	60	817490620	Screw Thdrol 3/8-16 x 1-1/4
3	532143364	Panel Asm., Side LH	63	819131614	Washer 13/32 x 3/4 x 14 Ga.
4	873680700	Nut, Crownlock 7/16-14 Unc	65	532149577	Strap, Asm. Hinge Front
5	532140452	Dash, Plastic Black	67	532140737	Guide, Belt
6	532145053	Dash 1-Pcs., Lower	68	817490508	Screw, Thdrol 5/16-18 x 1/2
7	817720408	Screw, Thd Cut 1/4-20 x 1/2	70	532137159	Guide, Belt Mid Span
8	532145166	Support, Battery	72	874180512	Screw, Mach Trhd 5/16-18 x 3/4
14	532125454	Hood Asm., Pnt	73	532406784	Strap, Asm. Hinge Rear
15	532124250	Lens, Headlight LH	74	874191008	Screw, Machine #10-24
16	532121794	Cover, Access	75	810071000	Washer, Lock #10
17	817490612	Screw, Thdrol 3/8-16 x 3/4	76	532125004	Nut, Weld #10-24
18	532127320	Grille	79	874981020	Screw, Machine #10-24 x 1/4
19	819131312	Washer 13/32 x 13/16 x 12 Ga.	80	532007206	Spacer, Split
20	874760616	Bolt, Fin Hex 3/8-16 x 1	81	819070818	Washer 7/32 x 1/2 x 18 Ga.
21	873680600	Nut, Crownlock 3/8-16 Unc	82	873731000	Nut #10-24
22	532143365	Panel Asm., Side RH	84	532142992	Stop, Over Center Mower
23	817490616	Screw, Thdrol. 3/8-16 x 1 Ty-Tt	85	532144911	Bracket, Support
24	532147202	Footrest, RH	86	874760716	Bolt, Fin Hex 7/16-14 Unc x 1
25	532124251	Lens Headlight RH	88	810040700	Washer, Lock Hvy Hld Sp 7/16
27	873220400	Nut, Fin Hex 1/4-20	90	811050600	Washer, Lock External Tooth 3/8
28	532127203	Footrest, LH	91	532144735	Rail, Frame Lh
29	532145205	Bracket, Support Dash	92	532141626	Plate, Silkscreen Dash
30	532148411	Saddle	94	532100207	Clip, Fuel Line
31	532145183	Bracket, Support Steering	95	532105531	Push Nut, Nylon
32	532141315	Bracket Asm., Frame Pivot Lh	106	532138776	Bolt 5/16 - 18 Type TT
33	532141314	Bracket Asm., Frame Pivot Rh	107	532109808	Latch, Chute Blk
34	532142131	Bracket, Engine Support Rear	108	532110356	Cap, Snap Black
35	819111116	Washer 11/32 x 11/16 x 16 Ga.	109	532110357	Cap, Washer Snap
36	874780512	Bolt, Fin Hex 5/16-18 x 3/4	110	532140625	Support Asm. Grille
37	532124927	Fender, Pnt.	111	532127316	Retainer
38	810040400	Washer, Lock 1/4	113	532123198	Nut, Plastic Locking Wing 1/4-20
39	532136961	Bracket, Axle Front	114	872140610	Bolt, Carriage 3/8-16 x 1-1/4
40	532142132	Bracket, Support Axle/Engine	115	532141460	Bumper Asm.
43	532136939	Bracket, Spnsn Front Lh	116	532141461	Bracket, Extension, Bumper
44	532136940	Bracket, Spnsn Front Rh	117	532143679	Plug, Plastic
45	532138460	Bracket Asm., Susp Chassis Rh	118	819131316	Washer 13/32 x 13/16 x 16 Ga.
46	819091216	Washer 9/32 x 3/4 x 16 Ga.	119	873680600	Nut Crownlock 3/8-16 UNC
47	817490608	Screw Thdrol 3/8-16 x 1/2	120	819131616	Washer 13/32 x 1 x 16 Ga.
50	532136575	Bracket, Chassis Front	123	532123481	Bolt Shoulder 1/4-20
52	873800500	Locknut, Hex W/Ins 5/16-18 Unc	124	873800400	Nut, Lock W/Ins 1/4-20
54	873510500	Nut 5/16-18	--	532125085	Plug, Hole
56	532138461	Bracket Asm., Susp Chassis Lh			
57	532108067	Nut, Pal			

NOTE: All component dimensions given in U.S. inches
1 inch = 25.4 mm

REPAIR PARTS

TRACTOR - MODEL NUMBER GT200 (954002012A)

GROUND DRIVE

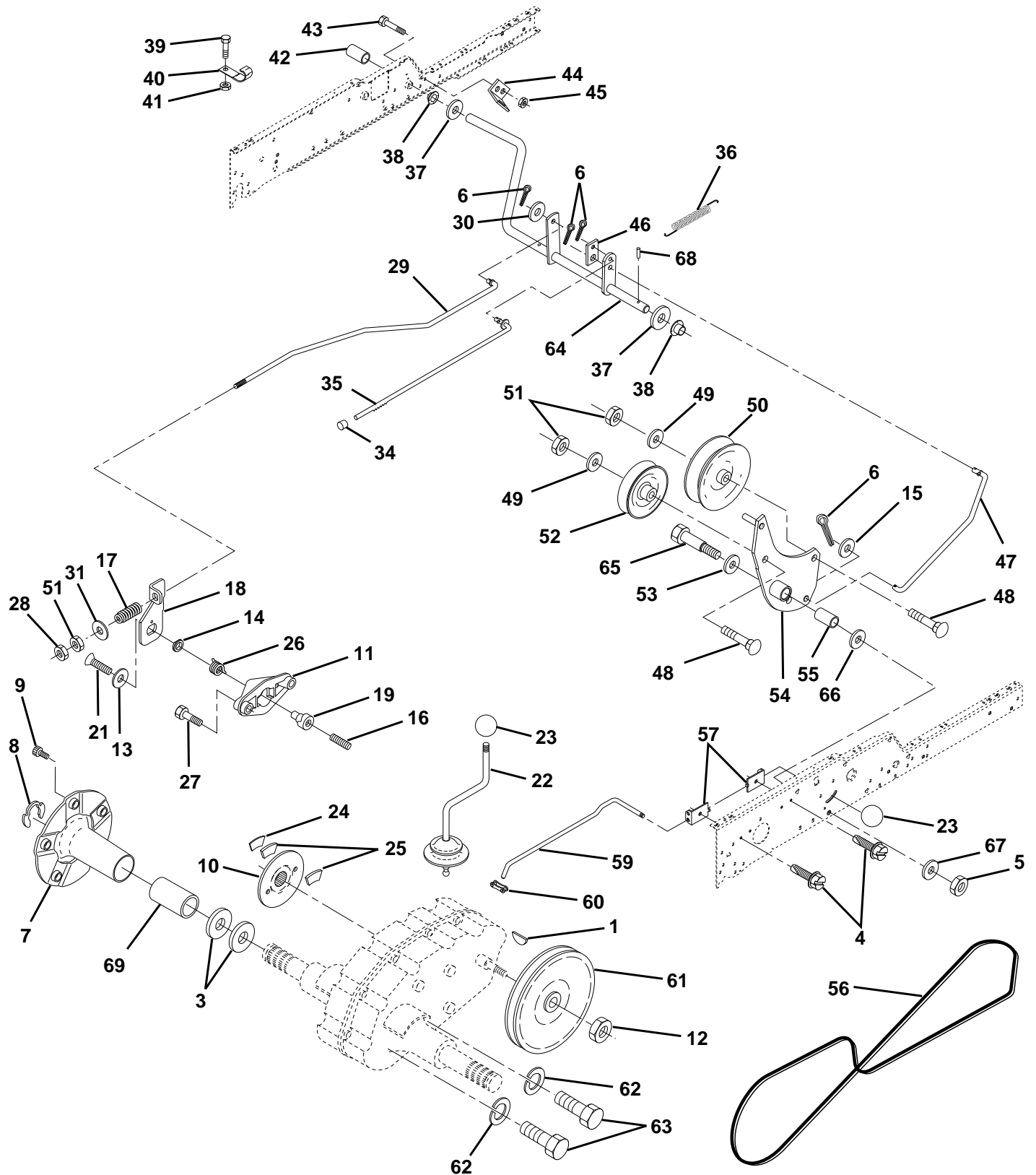

REPAIR PARTS

TRACTOR - MODEL NUMBER GT200 (954002012A)

GROUND DRIVE

KEY NO.	PART NO.	DESCRIPTION	KEY NO.	PART NO.	DESCRIPTION
1	532124708	Key Woodruff	38	532110895	Nyliner
3	532007563	Washer Thrust Axle Harden	39	874321016	Screw Fin #10-24 x 1
4	817490508	Screw Thdrol 5/16-18 x 1/2 TYT	40	532005304	Actuator Interlock Switch
5	873680600	Nut Crownlock 3/8-16	41	873631000	Nut Lock #10-24
6	876020412	Pin Cotter 1/8 x 3/4	42	532123533	Cover Pedal
7	532149176	Wheel Hub Asm.	43	874760412	Bolt Hex Head 1/4-20 x 3/4
8	812000034	Ring Klip	44	532104601	Bracket Interlock
9	532140080	Bolt Hub	45	873800400	Nut Lock W/Insert 1/4-20
10	532142509	Disc Brake	46	532145170	Retainer Spring
11	532136927	Yoke Brake Disc	47	532138228	Clutch Rod
12	532009204	Locknut 1/2-20	48	872110614	Bolt Carriage 3/8-16 x 1-3/4 Gr 5
13	532139419	Washer Special	49	819131413	Washer 13/32 x 7/8 x 13 Ga
14	532138901	Bushing	50	532131494	Pulley Idler Flat
15	819131316	Washer 13/32 x 13/16 x 16 Ga	51	873680600	Nut, Crownlock 3/8-16 Unc
16	532143012	Set Screw 1/4-28 x 3/4	52	532139123	Pulley Idler Grooved
17	532126909	Spring	53	532000207	Washer Hardened
18	532137104	Lever Brake	54	532138390	Clutch Arm Asm
19	532136926	Cam Brake Disc	55	532105706	Bearing, Idler
21	823260412	Screw Flat Head 1/4-28 x 3/4	56	532137153	V-Belt
22	532124863	Gearshift Lever Assembly	57	532141756	Bracket Shift Rod Hi-Lo
23	532121466	Knob	59	532122253	Shift RodHi-Lo
24	532136925	Support Puck Brake	60	532122268	Spring Clip Connecting Link
25	532136923	Puck Brake Top	61	532137524	Pulley Transaxle
26	532137552	Spring Return	62	810040700	Washer Lock 7/16
27	817490528	Screw Hex Wsh Thd 5/16-18 x 1-3/4	63	874760720	Bolt Fin Hex 7/16-14 x 1-1/4
28	873350600	Nut Hex Jam 3/8-16	64	532137649	Shaft Clutch/Brake Pedal
29	532137213	Brake Rod	65	532067609	Bolt Shoulder
31	819131616	Washer 13/32 x 1 x 16 Ga	66	532140296	Washer Hardened
34	532071673	Cap Plunger	67	819131312	Washer 13/32 x 13/16 x 12 Ga.
35	532137648	Rod Parking Brake	68	532005142	Pin Roll
36	532138364	Spring Extension	69	532136327	Hub Cover
37	532121749	Washer 25/32 x 1-1/4 x 16 Ga			

NOTE: All component dimensions given in U.S. inches
1 inch = 25.4 mm

REPAIR PARTS

TRACTOR - MODEL NUMBER GT200 (954002012A)

STEERING ASSEMBLY

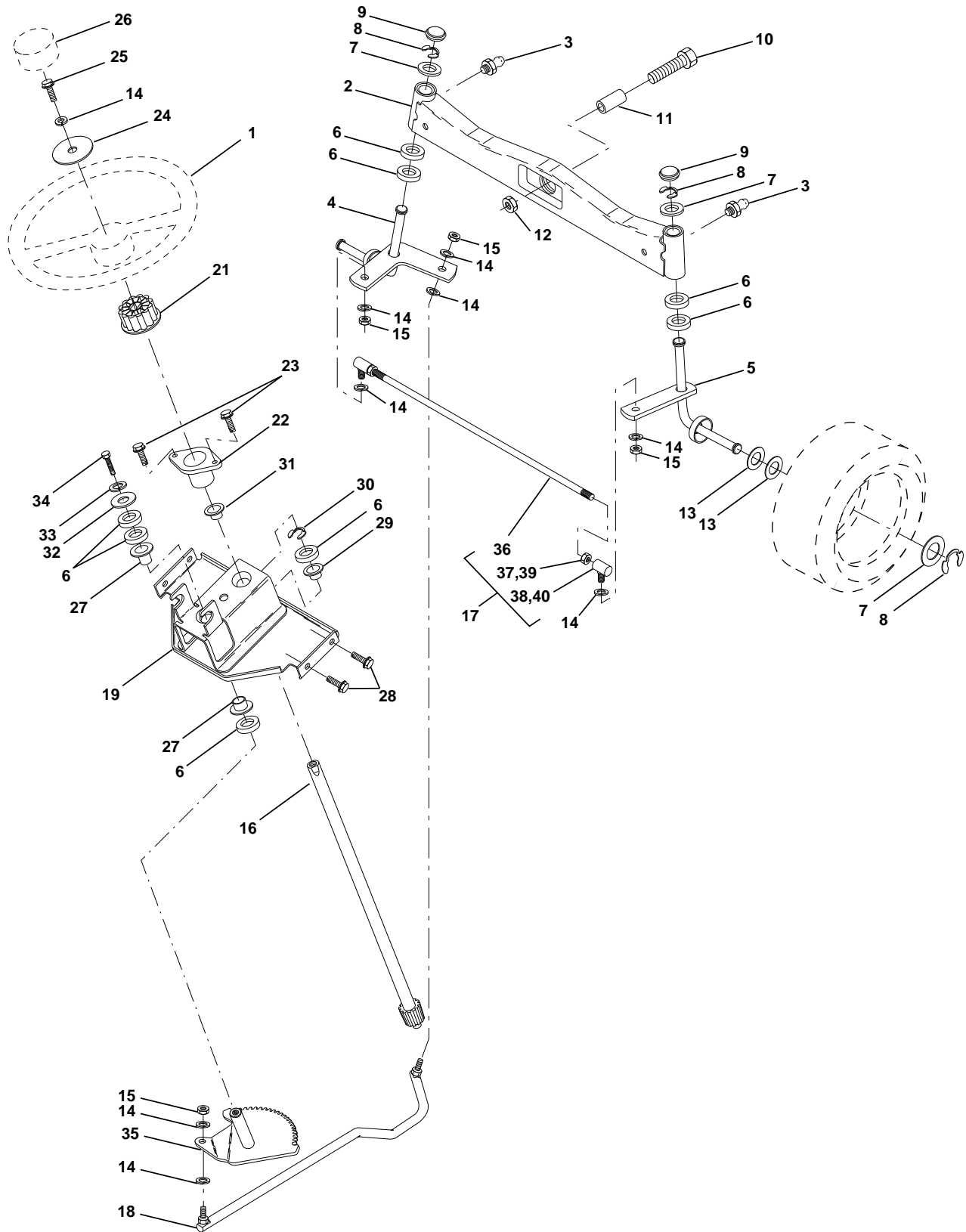

REPAIR PARTS

TRACTOR - MODEL NUMBER GT200 (954002012A)

STEERING ASSEMBLY

KEY NO.	PART NO.	DESCRIPTION
1	532124415	Wheel, Steering
2	532137094	Axle Asm., Front
3	532124836	Fitting, Grease
4	532136960	Spindle Asm, LH
5	532136959	Spindle Asm., RH
6	532124956	Bearing, Race Thrust Harden
7	532121748	Washer 25/32 x 1-5/8 x 16 Ga.
8	812000029	Ring, Klip #T5304-75
9	532121232	Cap, Spindle
10	874781044	Bolt, Fin Hex 5/8-11 x 2-3/4
11	532136518	Spacer, Brg. Axle Front
12	873901000	Nut, Lock Flange 5/8-11 Unc
13	532121749	Washer 25/32 x 1-1/4 x 16 Ga.
14	810040600	Washer, Lock Hvy Hlcl Spr 3/8
15	873610600	Nut, Fin Hex 3/8-24 Unf
16	532145103	Shaft Asm., Steering
17	532137347	Rod Asm., Tie Ball J Ball Vgt (Inc. Key No. 36-40)
18	532137155	Draglink, Ball Joint Solid Vgt
19	532146611	Support Asm., Steering Vgt
21	532100711	Adapter, Wheel Steering
22	532124720	Bushing, Strg. Blk
23	817431008	Screw, Slftp #10-16 x 1/2 Ty-b
24	819133808	Washer 13/32 x 2-3/8 x 8 Ga.
25	874780616	Bolt, Fin Hex 3/8-16 x 1 Gr. 5
26	532124416	Cap, Wheel Steering
27	532124937	Bearing, Col. Strg.
28	817490612	Screw Thdrol. 3/8-16 x 3/4 TY-TT
29	532104239	Bearing, Flange
30	812000034	Ring, Klip Truarc #5304-75
31	532138136	Bushing, Nyliner Snap
32	819111610	Washer 11/32 x 1 x 10 Ga.
33	810040500	Washer, Lock Hvy Hlcl Spr 5/16
34	874760512	Bolt, Hex Hd 5/16-18 x 3/4
35	532138059	Gear, Sector Steering
36	532137156	Tie Rod
37	873360600	Jam Nut RH Thread
38	532109850	Joint Asm. Ball RH Thread
39	873700600	Jam Nut LH Thread
40	532109851	Joint Asm. Ball LH Thread

NOTE: All component dimensions given in U.S. inches
1 inch = 25.4 mm

REPAIR PARTS

TRACTOR - MODEL NUMBER GT200 (954002012A)

ENGINE

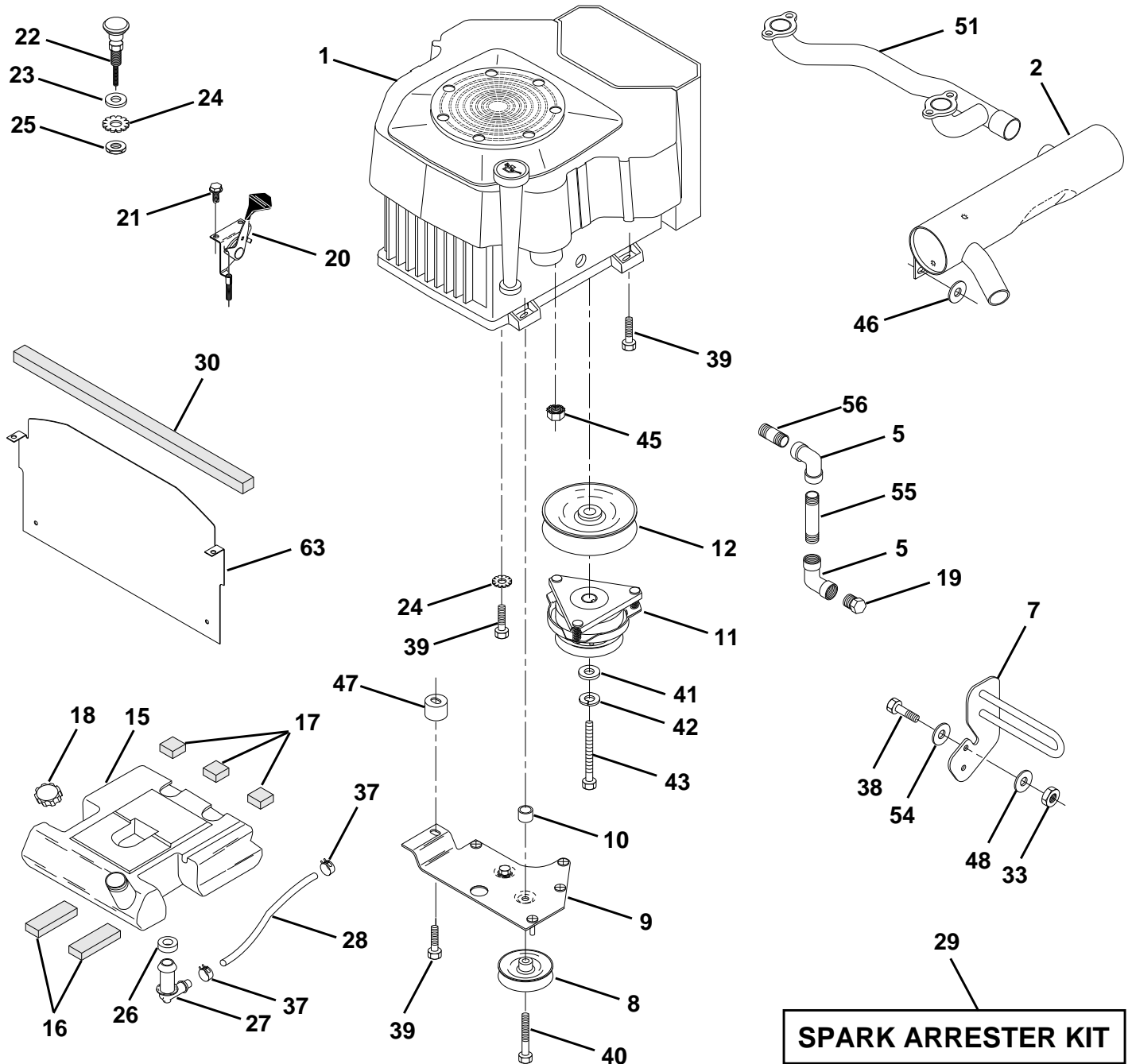

REPAIR PARTS

TRACTOR - MODEL NUMBER GT200 (954002012A)

ENGINE

KEY NO.	PART NO.	DESCRIPTION
1	-----	Engine Kohler, Model No. CV20S
2	532144636	Muffler VGT Cylinder
5	813200300	Elbow STD 90 Degree 3/8 - 18 NPT
7	532143599	Muffler Assembly Guard
8	532121361	Pulley V-Idler
9	532145109	Stop Keeper Asm VGT
10	532105432	Bushing
11	532140923	Clutch Electric
12	532143996	Pulley Engine VGT Elect Clutch
15	532141069	Tank Fuel W/Sym Vented
16	532109227	Pad Spacer
17	532106082	Pad Spacer
18	532140527	Cap Asm Fuel W/Sym Vented
19	813290300	Plug Oil Drain (Order From Engine Manufacturer)
20	532132747	Control Throttle
21	817720410	Screw Hex Thd Cut 1/4 - 20 X 5/8
22	532132781	Control Choke
23	819131316	Washer 13/32 X 13/16 x 16 Ga
24	811050600	Washer Ext Tooth 3/8
25	873610600	Nut Fin Hex 3/8 - 24 UNF
26	532124952	Bushing
27	532139277	Stem Tank Fuel
28	532124703	Fuel Line
29	532132920	Spark Arrester Kit
30	532105037	Strip Foam 18"
33	873800600	Nut, Hex W/Ins. 3/8-16 UNC
37	532123487	Clamp Hose
38	874780624	Bolt, Fin Hex 3/8-16 UNC x 1-1/2
39	817490636	Screw TT 3/8-16 x 2-1/4 UNC
40	817490664	Screw TT 3/8-16 x 4 UNC
41	532126197	Washer 1-1/2 OD X 15/32 ID X .250
42	810040700	Washer Lock 7/16
43	871170768	Bolt Hex 7/16-20 X 4-1/4 Ga 5
45	532128861	Nut, Flange 1/4-20 Starter Nut
46	819131616	Washer 13/32 x 1 x 16 Ga.
47	532142040	Spacer Engine CV22 Round PM
48	819132007	Washer 13/32 x 1-1/4 x 7 Ga.
51	532140787	Pipe Crossover CV22
54	819131414	Washer Flat 13/32 x 7/8 x 14 Ga.
55	813090336	Nipple, Pipe 3/8 N.P.T. x 4-1/2
56	813090308	Nipple, Pipe 3/8 NPT x 1.00
63	532145549	Shield, Heat VGT 22 HP YP/Husq.

NOTE: All component dimensions given in U.S. inches
1 inch = 25.4 mm

REPAIR PARTS

TRACTOR - MODEL NUMBER GT200 (954002012A)

SEAT ASSEMBLY

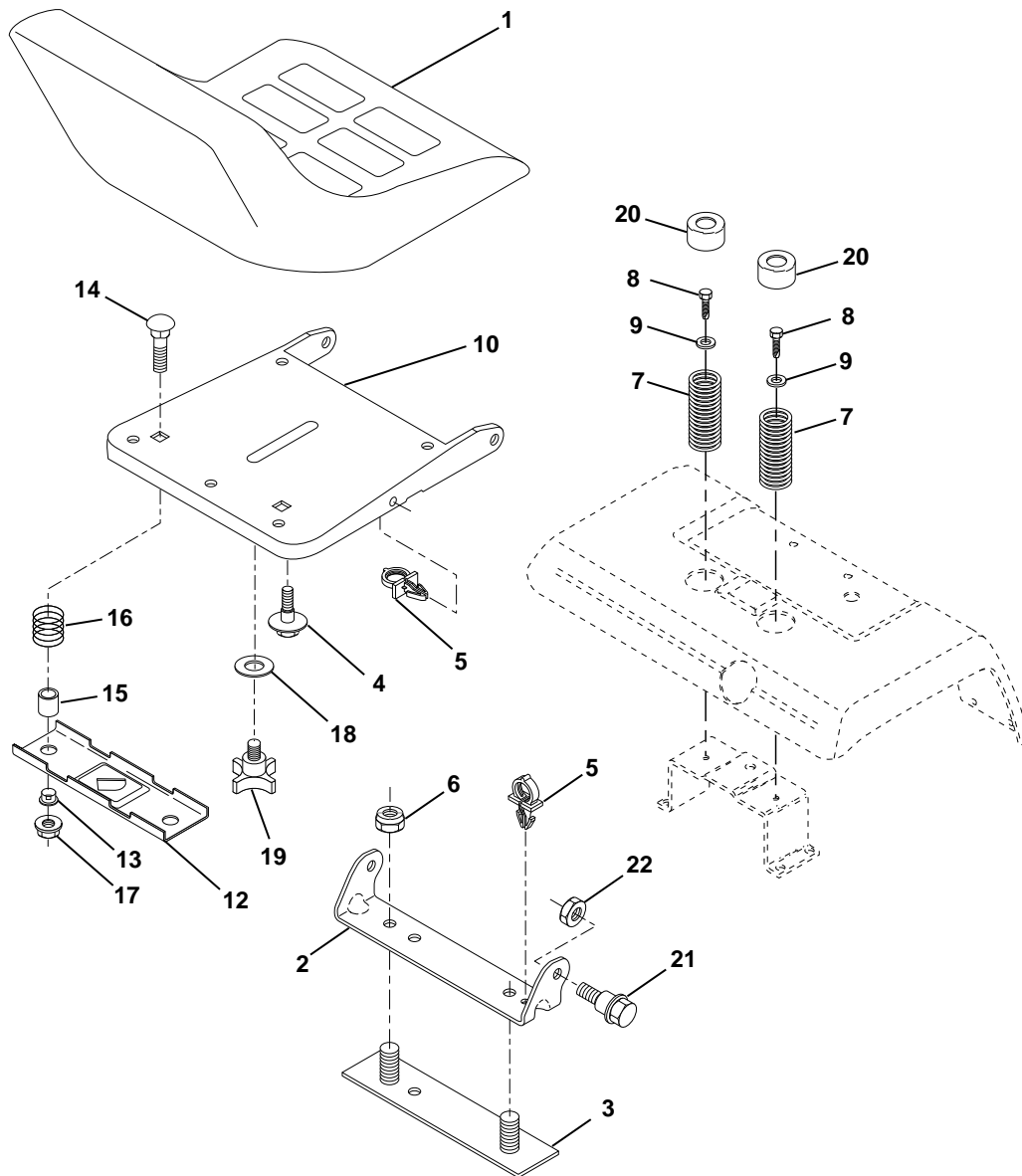

KEY NO.	PART NO.	DESCRIPTION
1	532141525	Seat
2	532140551	Bracket, Pivot Seat
3	532140675	Strap, Fender
4	532127018	Bolt, Shoulder 5/16-18 X .62
5	532145006	Clip, Push In Hinged
6	873800600	Locknut 3/8-16 Unc
7	532124181	Spring, Seat Cprsn
8	817490508	Screw, Thdrol 5/16-18 X 1/2
9	819131614	Washer 13/32 X 1 X 14 Ga.
10	532140552	Pan, Seat
12	532121246	Bracket, Mounting Switch
13	532121248	Bushing, Snap

KEY NO.	PART NO.	DESCRIPTION
14	872050411	Bolt, Carriage 1/4-20 X 1-3/8
15	532121249	Spacer, Split
16	532123740	Spring, Cprsn
17	532123976	Nut, Lock 1/4 Lge Flg Gr. 5
18	819171912	Washer 17/32 X 1-3/16 X 12 Ga.
19	532120068	Knob, Seat 1/2-13 Unc
20	532124238	Cap, Spring Seat
21	532139888	Bolt, Shoulder 5/16-18 Unc
22	873680500	Nut, Crownlock 5/16-18 Unc

NOTE: All component dimensions given in U.S. inches
1 inch = 25.4 mm

REPAIR PARTS

TRACTOR - MODEL NUMBER GT200 (954002012A)

MOWER LIFT

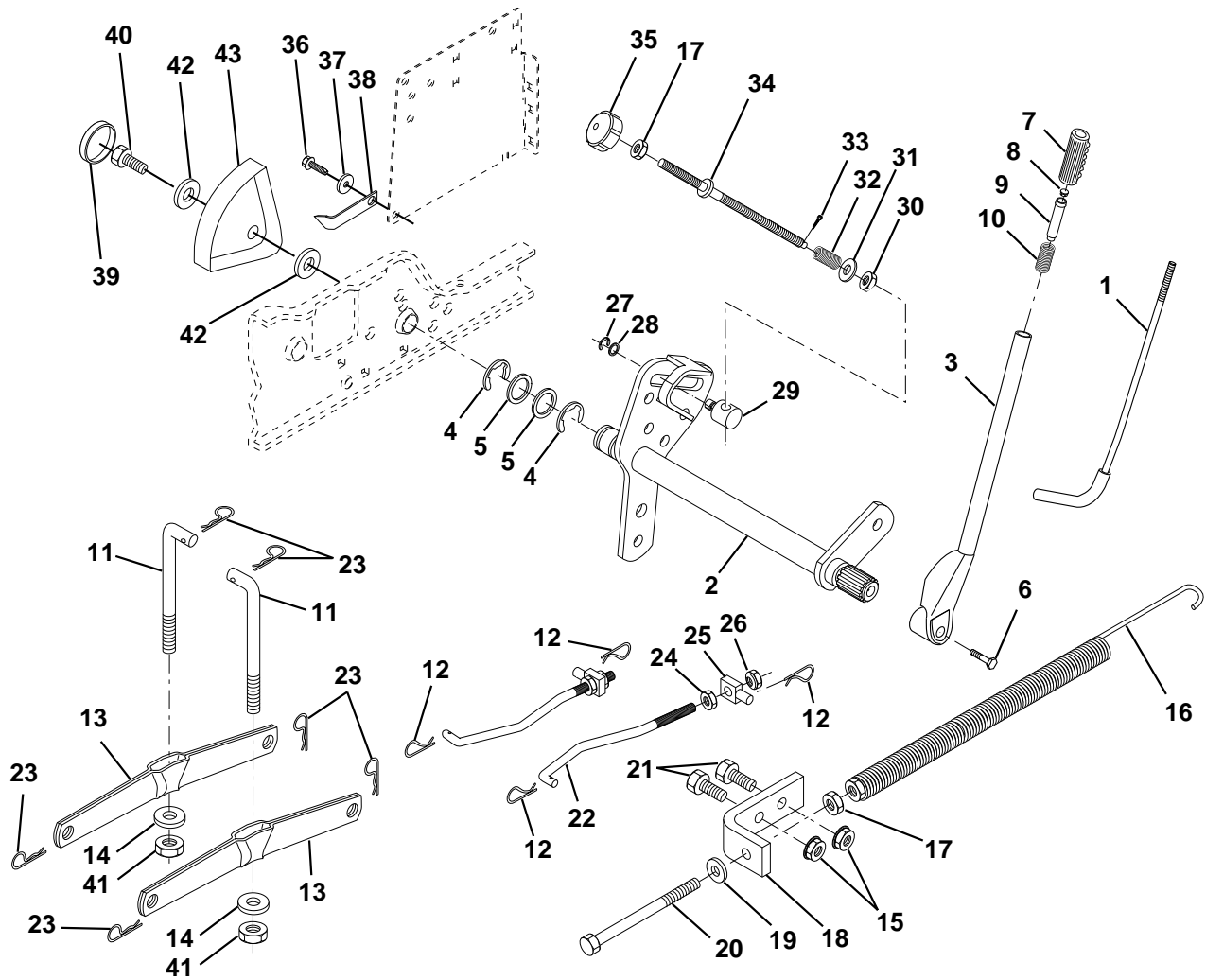

KEY NO.	PART NO.	DESCRIPTION	KEY NO.	PART NO.	DESCRIPTION
1	532121006	Rod Asm., Lever	24	873350800	Nut, Jam Hex 1/2-13 Unc
2	532145542	Shaft Asm., Lift Vgt	25	532130171	Trunnion
3	532121002	Lever Asm., Lift Rh	26	873800800	Nut, Lock W/Wsh 1/2-13 Unc
4	812000022	E-Ring Truarc #5133-87	27	812000037	Ring, Klip #T5304-37
5	819292016	Washer 29/32 x 1-1/4 x 16 Ga.	28	819151216	Washer 15/32 x 3/4 x 16 Ga.
6	874780624	Bolt, Fin Hex 3/8-16 x 1-1/2	29	532110810	Trunnion, Dp Stop Dbl Thds Plt
7	532125631	Grip, Handle Fluted	30	532110807	Nut, Special
8	532124526	Button, Plunger	31	819131016	Washer 13/32 x 5/8 x 16 Ga.
9	532122364	Plunger, Lever Lift	32	532137150	Spring, Compression Inf Hgt
10	532124874	Spring 2-1/8"	33	876020308	Pin, Cotter 3/32 x 1/2
11	532146704	Link Lift	34	532137167	Rod, Adj Lift
12	532124660	Retainer, Spring	35	532138057	Knob, Inf 3/8-16 Unc
13	532139868	Arm, Suspension Vgt	36	817490612	Screw, Thdrol 3/8-16 x 3/4
14	532140302	Bearing	37	532120529	Washer, Nylon
15	873680600	Nut, Crownlock 3/8-16 Unc	38	532138346	Pointer, Ntl Height Indicator
16	532124687	Spring Asm., Assist Lift	39	532123935	Plug, Hole
17	873350600	Nut, Hex Jam 3/8-16 Unc	40	817490512	Screw Thdrol. 5/16-18 x 3/4
18	532143363	Bracket, Spring Assist	41	873540600	Nut, Crownlock 3/8-24
19	819131316	Washer 13/32 x 13/16 x 16 Ga.	42	819112410	Washer 11/32 x 1-1/2 x 10 Ga.
20	532005328	Bolt, Adjust Spring Assist	43	532123934	Scale, Indicator Height
21	874760616	Bolt, Fin Hex 3/8-16 x 1			
22	532127218	Link, Front			
23	532124670	Retainer, Spring			

NOTE: All component dimensions given in U.S. inches
1 inch = 25.4 mm

REPAIR PARTS

TRACTOR - MODEL NUMBER GT200 (954002012A)

MOWER DECK

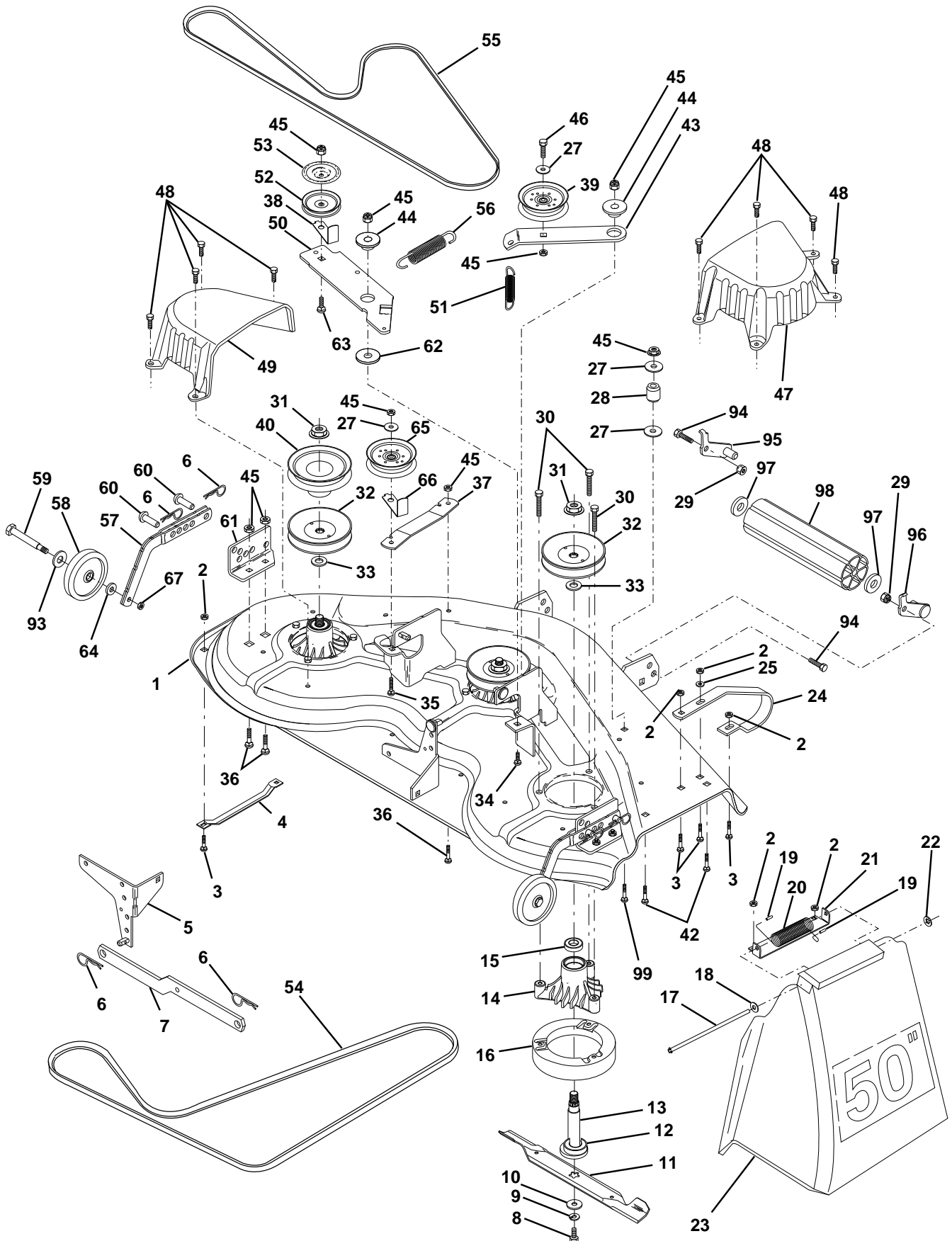

REPAIR PARTS

TRACTOR - MODEL NUMBER GT200 (954002012A)

MOWER DECK

KEY NO.	PART NO.	DESCRIPTION	KEY NO.	PART NO.	DESCRIPTION
1	532136457	Deck Asm., Mower 50" Vented	42	872140506	Bolt, Carriage 5/16-18 Unc x 3/4
2	873680500	Nut, Crownlock 5/16-18	43	532136460	Arm, Idler Secondary
3	872110506	Bolt, Carriage 5/16-18 x 3/4	44	532122052	Spacer, Retainer
4	532125074	Runner, Mower LH	45	873680600	Nut, Crownlock 3/8-16 Unc
5	532138457	Bracket Asm., Sway Bar	46	874760628	Bolt, Fin Hex 3/8-16 Unc x 1-3/4
6	532124670	Retainer, Spring	47	532137200	Cover, Mandrel RH
7	532130832	Arm Suspension, Rear	48	532137729	Screw, Thd Roll 1/4-20 x 5/8
8	532850857	Bolt 3/8-24 x 1.25 Gr. 8 Patched	49	532136574	Cover, Mandrel LH
9	810030600	Washer, Lock Hvy 3/8 Unplated	50	532137272	Arm, Idler Primary
10	532140296	Washer, Hard Blade Mower Vented	51	532137273	Spring, Secondary
11	532137380	Blade (3 Required)	52	532139245	Pulley, Idler V Groove
12	532129895	Bearing, Ball #6204 (Mandrel)	53	532137789	Shield, Idler
13	532137553	Shaft Asm., W/Lower Brg (Includes Key No. 12)	54	532139573	V-Belt, Mower Primary
14	532137152	Housing, Mandrel 50" Vent	55	532144959	V-Belt, Mower Secondary
15	532110485	Bearing, Ball Mandrel	56	532138687	Spring, Primary
16	532140329	Stripper, Mower Vented	57	532136577	Bar Asm., Wheel Gauge
17	532106735	Rod, Hinge	58	532105455	Wheel, Gauge
18	819111016	Washer 11/32 x 5/8 x 16 Ga.	59	532124842	Bolt, Shoulder
19	532105304	Cap, Sleeve	60	532139031	Pin, Clevis
20	532123713	Spring, Torsion Deflector	61	532136573	Bracket, Wheel Gauge
21	532137607	Bracket, Deflector	62	532133943	Washer Hardened
22	532110452	Nut, Push	63	872110612	Bolt Carriage 3/8-16 x 1-1/2
23	532110509	Shield, Deflector Mower	64	819121414	Washer 3/8 x 7/8 x 14 Ga.
24	532136320	Runner, RH	65	532102403	Pulley Idler Flat Mower
25	819111216	Washer 11/32 x 3/4 x 16 Ga.	66	532139622	Keeper, Belt Idler 50" Vent
27	819131316	Washer 13/32 x 13/16 x 16 Ga.	67	873930600	Nut, Center Lock 3/8-16
28	532132823	Spacer, Spring Stop Idler	93	819171512	Washer 17/32 x 15/16 x 12 Ga.
29	873800600	Nut, Lock Hex W/Wsh 3/8-16 Unc	94	874760616	Bolt, Fin Hex 3/8-16 x 1
30	532138776	Screw Thdrol Hex Head	95	532132274	Bracket, Asm. Noseroller LH
31	532137266	Nut, Flg Top Lock Cntr 9/16	96	532132273	Bracket, Asm. Noseroller RH
32	532129861	Pulley, Mandrel	97	819171416	Washer 17/32 x 7/8 x 16 Ga.
33	532129963	Washer, Spacer Mower Vented	98	532132264	Roller, Nose
34	872140610	Bolt, Carriage 3/8-16 x 1-1/4	99	872110614	Bolt, Carriage 3/8-16 x 1-3/4 Gr. 5
35	872110616	Bolt, Carriage 3/8-16 x 2	--	532143651	Mandrel Asm - Service (Includes Key Nos. 8-10, 12-15, 31 and 33)
36	872110608	Bolt, Carriage 3/8-16 x 1 Gr. 5	--	532141051	Mower Asm - Service (Standard Deck - Order separately all gauge wheel and nose roller components)
37	532137166	Stiffener, Arm Idler			
38	532137554	Keeper, Belt Idler			
39	532131494	Pulley, Idler Flat			
40	532136572	Pulley, Driven			

NOTE: All component dimensions given in U.S. inches
1 inch = 25.4 mm

REPAIR PARTS

TRACTOR - MODEL NUMBER GT200 (954002012A)

TRANSAXLE

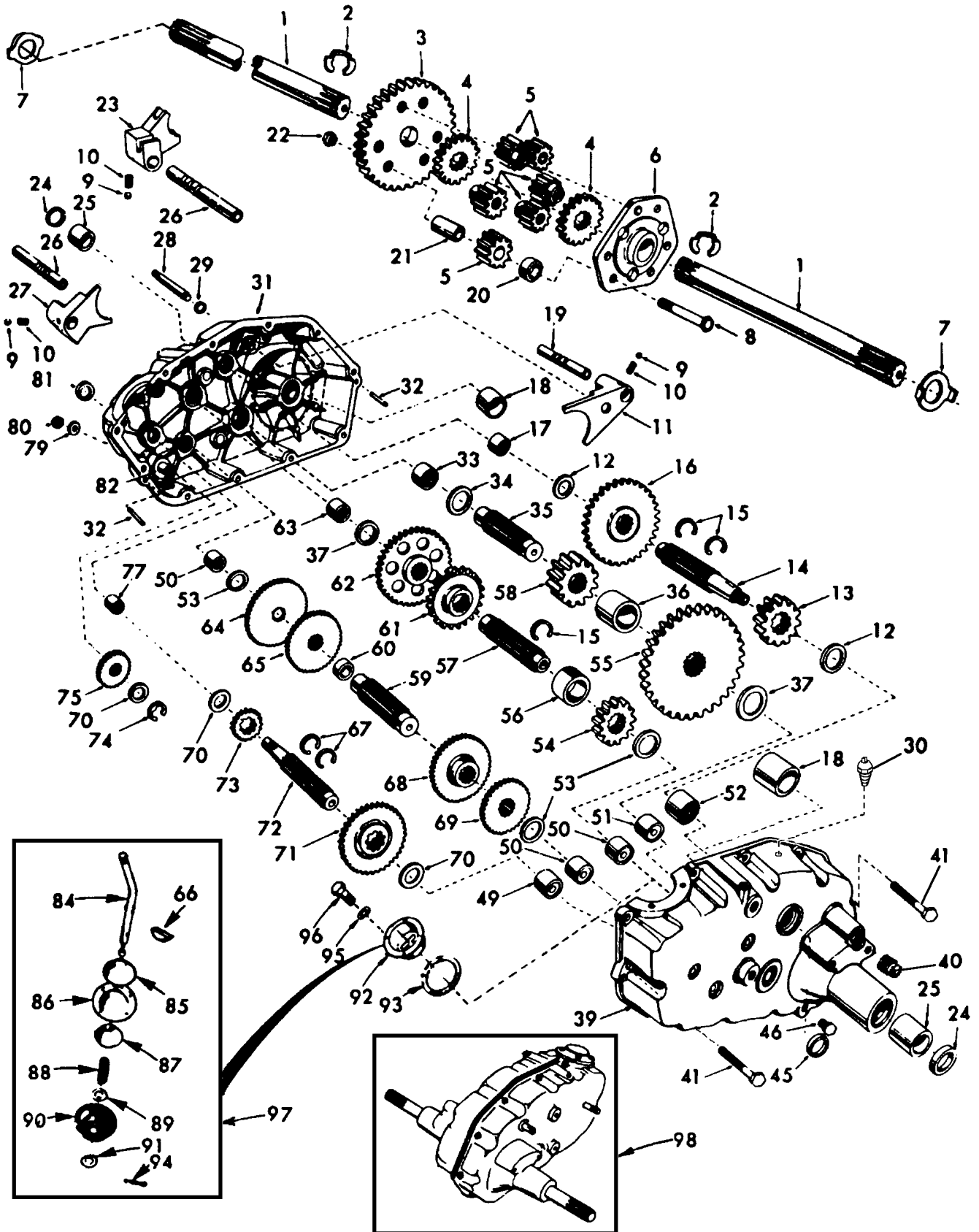

REPAIR PARTS

TRACTOR - MODEL NUMBER GT200 (954002012A)

TRANSAXLE

KEY PART NO.	NO.	DESCRIPTION	KEY PART NO.	NO.	DESCRIPTION
1	532124662	Axle Shaft	52	532008119	Needle Bearing
2	812000034	Retaining Ring	53	532004220	Thrust Bearing Race
3	532004199	Final Drive Gear	54	532004209	3rd Reduction Pinion, Low
4	532004216	Differential Gear	55	532124668	4th Reduction Gear
5	532004215	Differential Pinion	56	532004442	3rd Reduction Pinion Spacer
6	532004217	Differential Carrier	57	532004195	2nd Reduction Gear Shaft
7	532124674	Axle Thrust Washer	58	532004214	Final Drive Pinion
8	874020652	Bolt, Hex Head 3/8-24 x 3-1/4 (1" Thread Length)	59	532004194	1st Reduction Gear Shaft
9	532124697	Steel Ball	60	532007528	1st Reduction Shaft Spacer
10	532137261	Spring Shift Fork Detent	61	532124666	3rd Reduction Pinion High
11	532004985	Shift Fork, High-Low Range	62	532124665	2nd Reduction Gear
12	532124931	Thrust Bearing Race	63	532007398	Needle Bearing
13	532124667	4th Reduction Pinion	64	532124664	Low Speed Gear and 2nd Reduction Pinion Cluster
14	532137125	3rd Reduction Gear Shaft	65	532004204	Reverse Gear
15	532124677	Snap Ring, Crescent Type	66	532002898	Key, Hi-Pro 1/8 x 17/32
16	532124679	High-Low Range Gears	67	812000033	Snap Ring, Crescent Type
17	532008118	Needle Bearing	68	532004205	Intermediate Speed Gear
18	532124705	Sintered Iron Bearing	69	532125099	High Speed Gear
19	532122238	Shift Fork Shaft, High-Low Range	70	532001370	Thrust Bearing Race
20	532004218	Differential Pinion Spacer	71	532124681	Intermediate and High Speed Cluster Pinions
21	532124673	Differential Pinion Bushing	72	532139120	Input Shaft
22	532124701	Gripco Centerlock Nut 3/8-24	73	532004201	Low Speed Pinion
23	532006262	Shift Fork, R.H.	74	812000008	E-Ring
24	532124698	Oil Seal	75	532001153	Reverse Idler Gear
25	532124709	Sintered Iron Bearing	77	532006803	Needle Bearing
26	532139111	Shift Fork Shaft	79	532001167	Sealing Washer
27	532004986	Shift Fork, L.H.	80	873360700	Nut, Hex, Jam 7/16-20
28	532122254	Shift Shaft, High-Low Range	81	532124675	Oil Seal
29	532006269	Oil Seal	82	532136984	Reverse Idler Shaft
30	532005855	Pressure Relief Valve	84	532005384	Gearshift Lever, Bent
31	532139538	Gearcase, Reverse Idler Shaft and Bearings, R.H. (Includes Key No.'s 17, 18, 25, 33, 50, 63, 77 and 82)	85	532002978	Gearshift Cap
32	532006277	Dowel Pin	86	532124682	Gearshift Ball Cover and Pin
33	532004225	Needle Bearing	87	532124704	Shift Lever Guide Ball, Keyed
34	532007396	Thrust Bearing Race	88	532004924	Spring
35	532004198	4th Reduction Gear Shaft	89	819151516	Washer 15/32 x 15/16 x 16 Gauge
36	532124663	4th Reduction Gear Spacer	90	532110542	Shift Mechanism Seal
37	532007395	Thrust Bearing Race	91	819181511	Washer 9/16 x 15/16 x 12 Gauge
39	532139536	Gearcase and Bearings, L.H. (Includes Key Numbers 18, 25, 49, 50 (2), 51 and 52)	92	532000075	Gearshift Gate and Reinforcement
40	813320400	Pipe Plug 1/2-14 N.P.T.	93	532006274	Shift Ball Cover Gasket
41	817580520	Bolt, Hex 5/16-18 UNC x 1-1/4	94	876020412	Cotter Pin 1/8 x 3/4
45	532006271	Oil Seal	95	810040500	Washer, Lock 5/16
46	813060200	Pipe Plug 1/4-18 N.P.T.	96	874760514	Bolt, Hex Head 5/16-18 UNC x 7/8
49	532124792	Needle Bearing	97	532124863	Gear Shift Lever Assembly
50	532004222	Needle Bearing	98	532140332	Transaxle, 6 Speed, Complete Assembly
51	532001529	Needle Bearing			

NOTE: All component dimensions given in U.S. inches
1 inch = 25.4 mm