

GTH 200

(954001122VA), 954001992

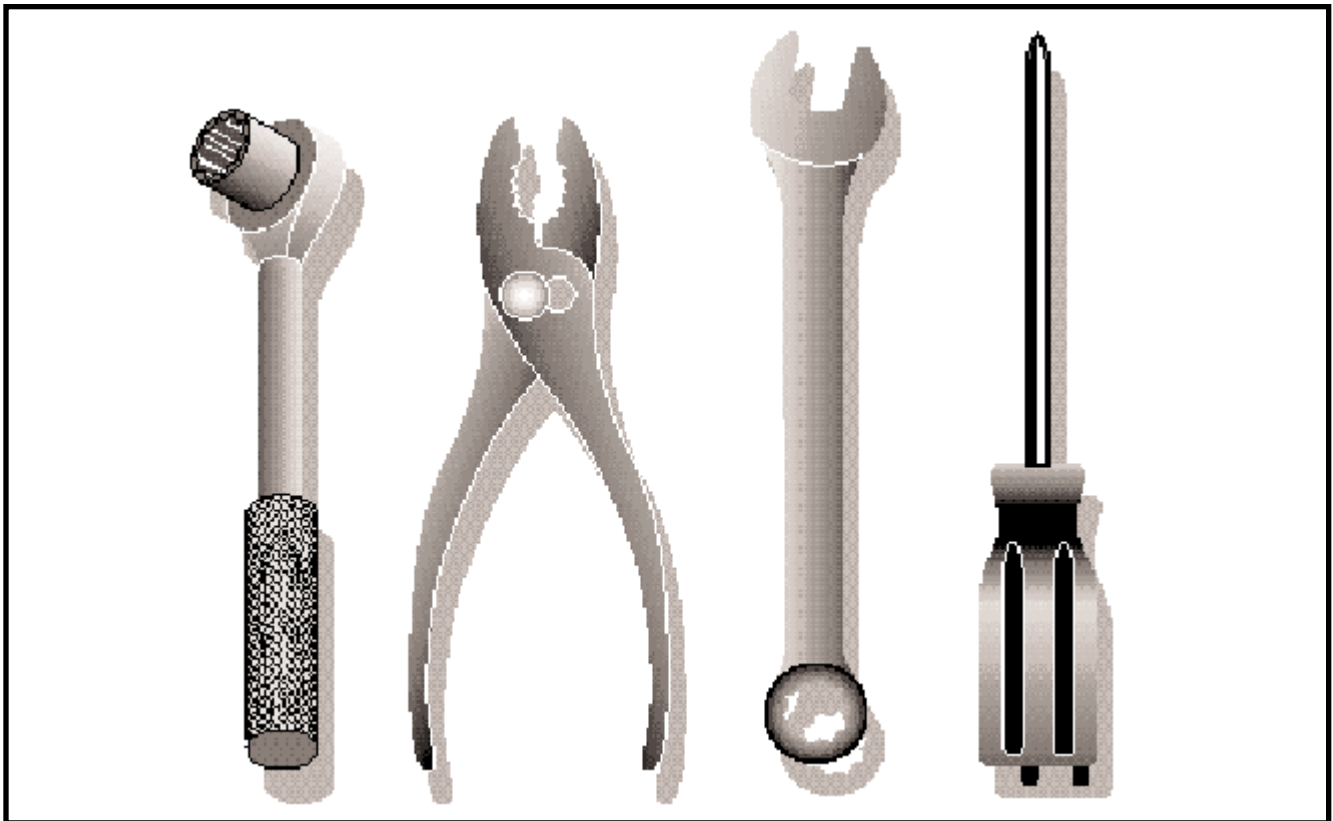

Repair Parts Manual

Ride Mower

TRACTOR - - MODEL NO. GTH200 (954001122VA), PRODUCT NO. 954 00 19-92

SCHEMATIC

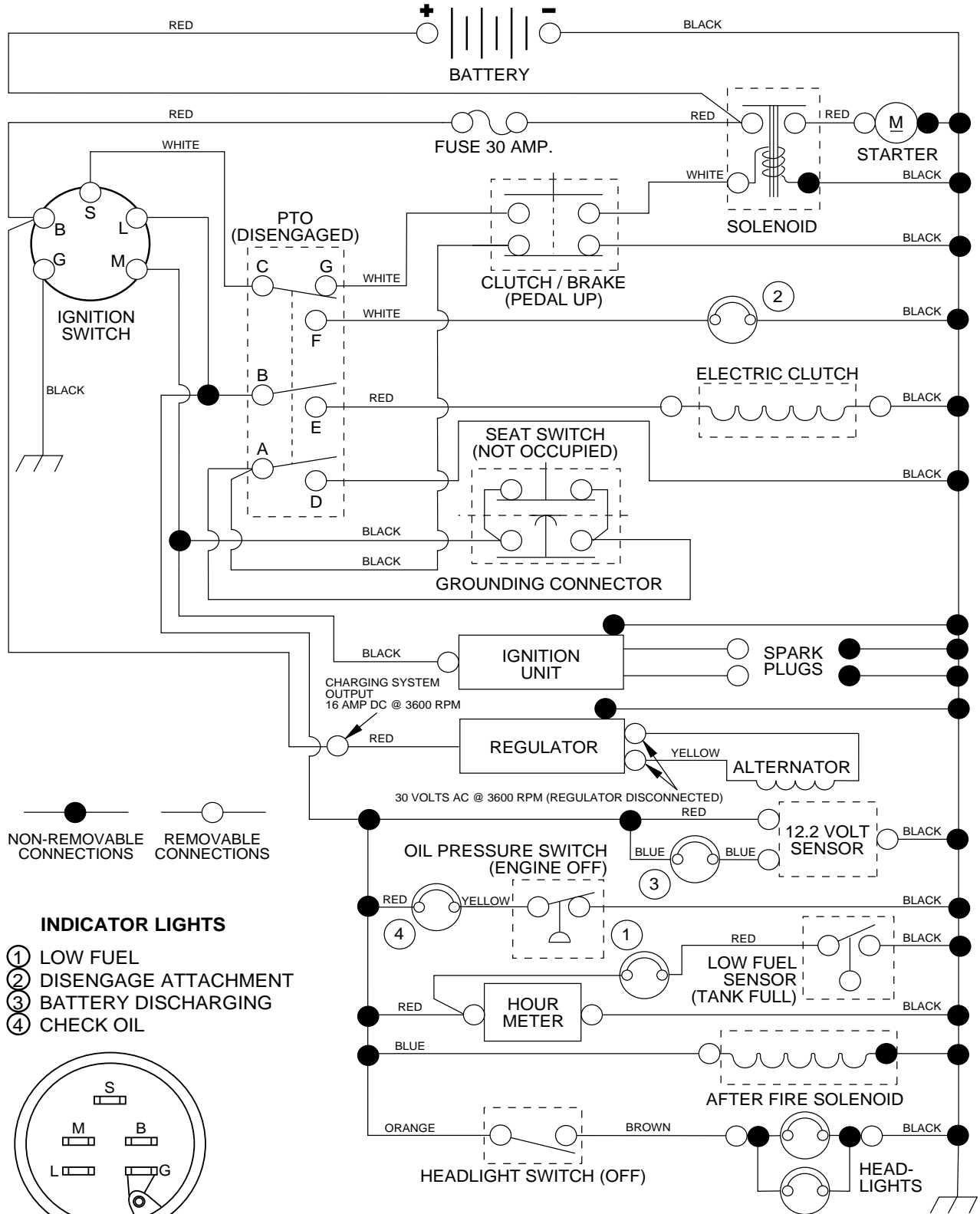

NON-REMOVABLE CONNECTIONS REMOVABLE CONNECTIONS

INDICATOR LIGHTS

- ① LOW FUEL
- ② DISENGAGE ATTACHMENT
- ③ BATTERY DISCHARGING
- ④ CHECK OIL

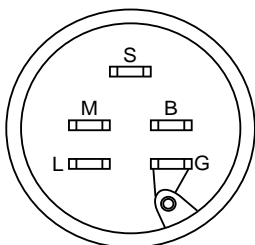

IGNITION SWITCH

POSITION	CIRCUIT
OFF	M + G
ON	B + L
START	B + S + L

WIRING INSULATED CLIPS
NOTE: IF WIRING INSULATED CLIPS WERE REMOVED FOR SERVICING OF UNIT, THEY SHOULD BE REPLACED TO PROPERLY SECURE YOUR WIRING.

PTO SWITCH

POSITION	CIRCUIT
OFF	C + G
ON	C + F, B + E, A + D

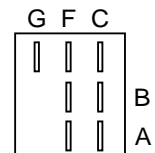

REPAIR PARTS

TRACTOR - - MODEL NO. GTH200 (954001122VA), PRODUCT NO. 954 00 19-92

DECALS

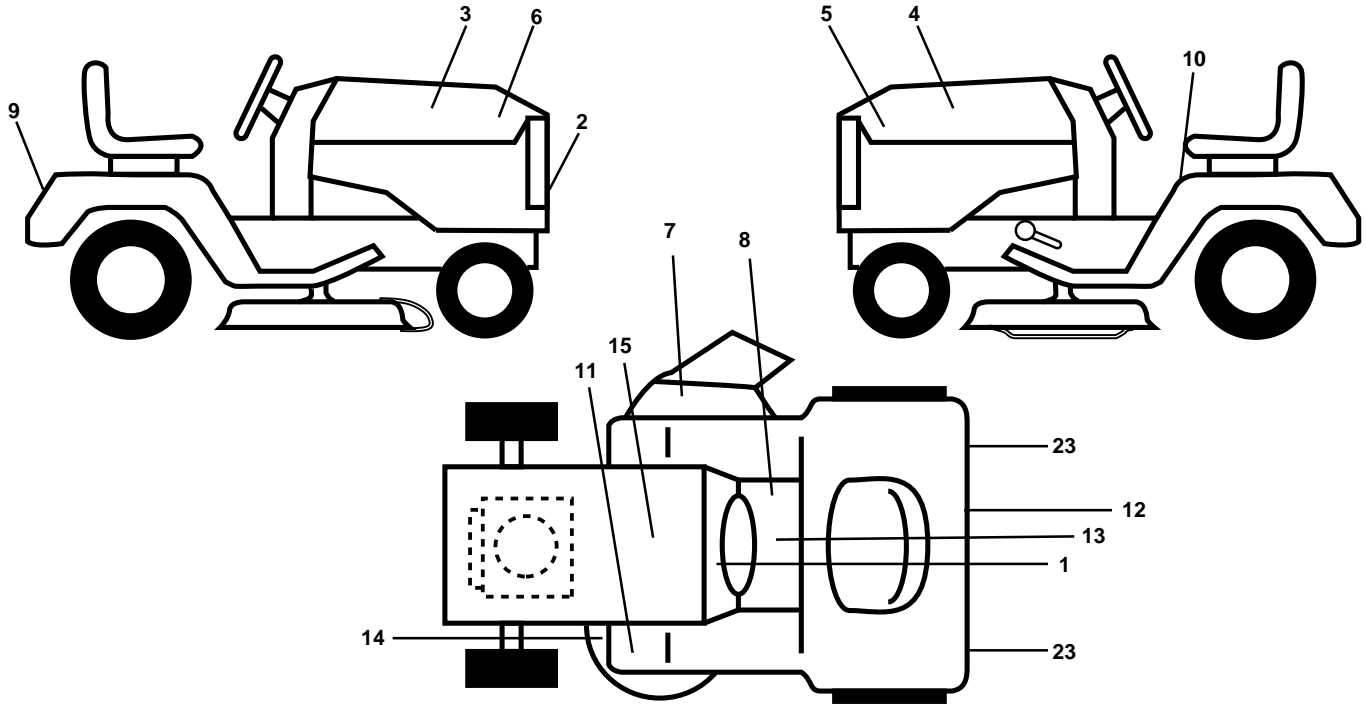

KEY NO.	PART NO.	DESCRIPTION	KEY NO.	PART NO.	DESCRIPTION
1	532138956	Decal, Operating Instruction	13	532142337	Decal, Cold Start
2	532125989	Decal, Grille Husqvarna "H" Logo	14	532139346	Decal, V-Belt Schematic
3	532140728	Decal, Hood, RH	15	532145005	Decal Bat Dan/Poi P/L Symbols
4	532140729	Decal, Hood, LH	23	532106202	Reflector, Taillight
5	532140869	Decal, Inst Hood LH GTH200 Hydro	--	532138311	Decal, Handle Lft Height Adjust (Lift Handle)
6	532140868	Decal, Insrt Hood RH GTH200 Hydro	--	532145246	Pad Footrest
7	532137259	Decal, Warning Multi-Language	--	532145247	Fastener Pop-In Footrest (8 per)
8	532140837	Decal, Brake Parking Saddle	--	532149883	Manual, Owner's (English)
9	532131582	Decal, Fender	--	532149884	Manual, Owner's (French)
10	532133795	Decal, Caution	Accessories not included with tractor:		
11	532101892	Decal, Clutch/Brake	--	SH10	Sleeve Hitch
12	532142342	Decal, D-Bar Ctrl. Mvt Hyd YT/GT	--	TA128	Tire Chains
			--	EA20	Electric Assist
			--	TA321	#55 Wheel Weights
			--	GBD48	Snow Blade
			--	GSB42	Snow blower

WHEELS & TIRES

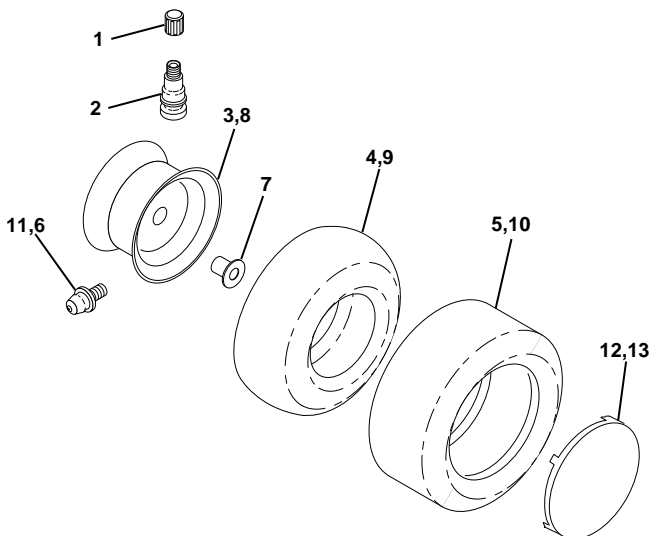

KEY NO.	PART NO.	DESCRIPTION
1	532059192	Cap, Valve, Tire
2	532065139	Stem, Valve
3	532141624	Rim Assembly, Front
4	532008134	Tube, Front (Service Item Only)
5	532106230	Tire, Front
6	532124957	Fitting, Grease
7	532124959	Bearing, Flange (Front Wheel Only)
8	532141625	Rim Assembly, Rear
9	532007154	Tube, Rear (Service Item Only)
10	532105588	Tire, Rear
11	532124860	Fitting, Grease
12	532124578	Cover Wheel 8" White
13	532124579	Cover, Wheel 12" White
--	532144334	Sealant, Tire (10 oz. Tube)

NOTE: All component dimensions given in U.S. inches
1 inch = 25.4 mm

REPAIR PARTS

TRACTOR - - MODEL NO. GTH200 (954001122VA), PRODUCT NO. 954 00 19-92
ELECTRICAL

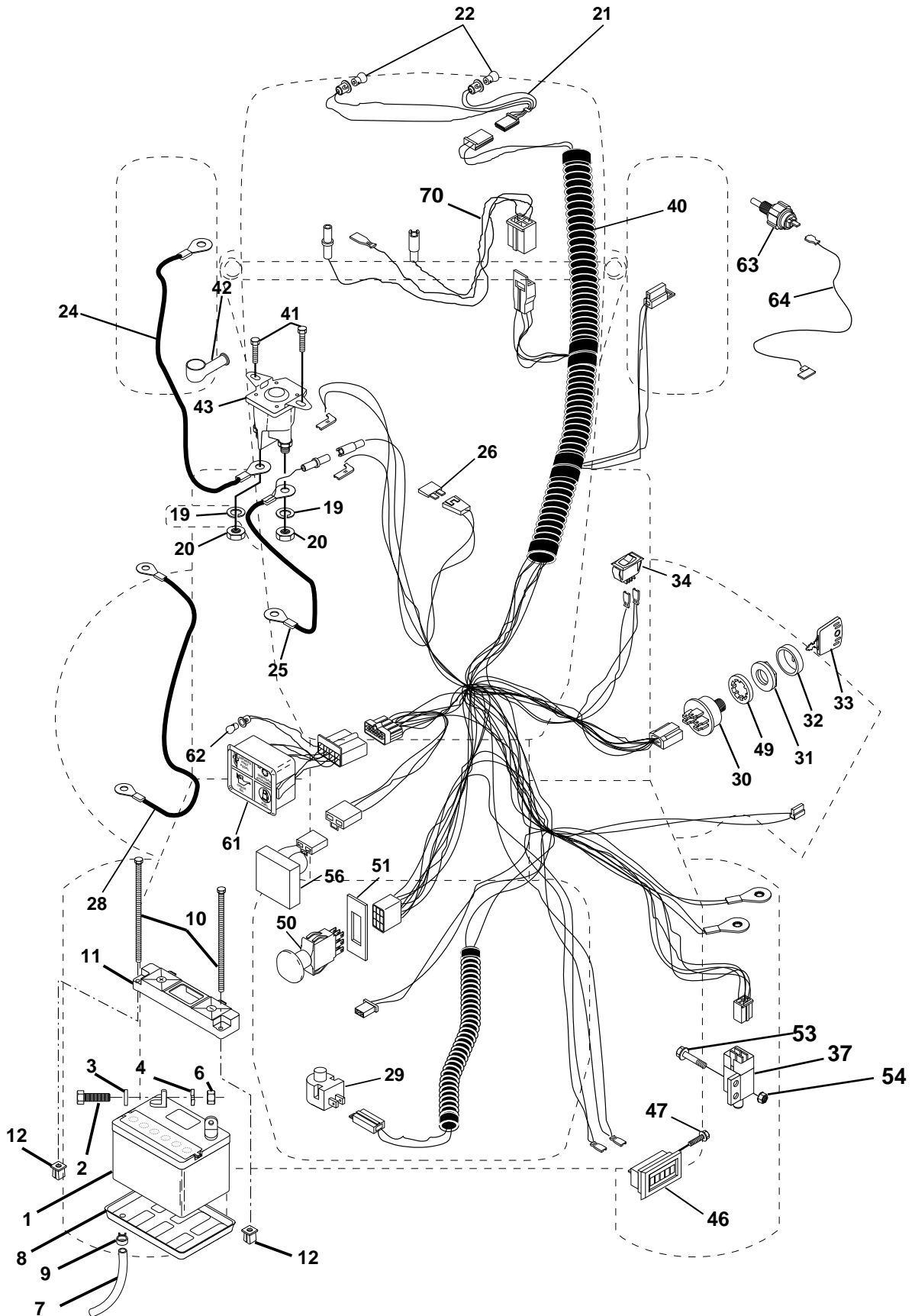

REPAIR PARTS

TRACTOR - - MODEL NO. GTH200 (954001122VA), PRODUCT NO. 954 00 19-92
ELECTRICAL

KEY NO.	PART NO.	DESCRIPTION
1	532144926	Battery
2	874760412	Bolt Hex Head 1/4-20 x 3/4
3	810040400	Washer, Lock 1/4
4	819091016	Washer 9/32 x 5/8 x 16 Ga
6	873220400	Nut Fin Hex 1/4-20
7	532007697	Tube Plastic
8	532124886	Tray, Battery
9	532109596	Clamp, Hose
10	532145211	Bolt, Battery Frt 1/4-20 x 7.5 Zinc
11	532145209	Holddown Battery Dash Mount
12	532145769	Nut, Push Nylon 1/4" Battery
19	810090400	Washer, Lock 1/4
20	873350400	Nut, Jam Hex 1/4-20
21	532136850	Harness Socket Light W/4152J
22	532004152	Bulb Light
24	532124770	Cable, Starter
25	532146149	Cable, Battery
26	532108824	Fuse
28	532124773	Cable, Ground
29	532121305	Switch, Plunger
30	532144921	Switch, Ign
31	532140400	Nut, Ignition Switch
32	532141226	Cover Switch Key
33	532140401	Key
34	532110712	Switch, Light
37	532109553	Intlk Switch
40	532146067	Harness Ign.
41	817720408	Screw 1/4-20 x 1/2
42	532131563	Cover, Terminal Red
43	532145673	Solenoid
46	532110940	Meter Hour
47	817011008	Screw #10-24 x 1/2
49	811151000	Washer, Lock Internal Tooth 5/8
50	532140404	Switch, PTO
51	532140405	Ring Retainer PTO
53	871031008	Screw Hex Washer Hd #10-32 x 1
54	873951000	Nut Keps #10-32
56	532127385	Sensor Lo-Volt
61	532126519	Light Pkg Asm
62	532110143	Bulb, Light Pkg.
63	532142320	Switch Engine Oil Pressure
64	532144222	Wire, Lead Sentry Oil Vanguard
70	532141983	harness Engine Vanguard II VGT

NOTE: All component dimensions given in U.S. inches
1 inch = 25.4 mm

REPAIR PARTS

TRACTOR - - MODEL NO. GTH200 (954001122VA), PRODUCT NO. 954 00 19-92
CHASSIS AND ENCLOSURES

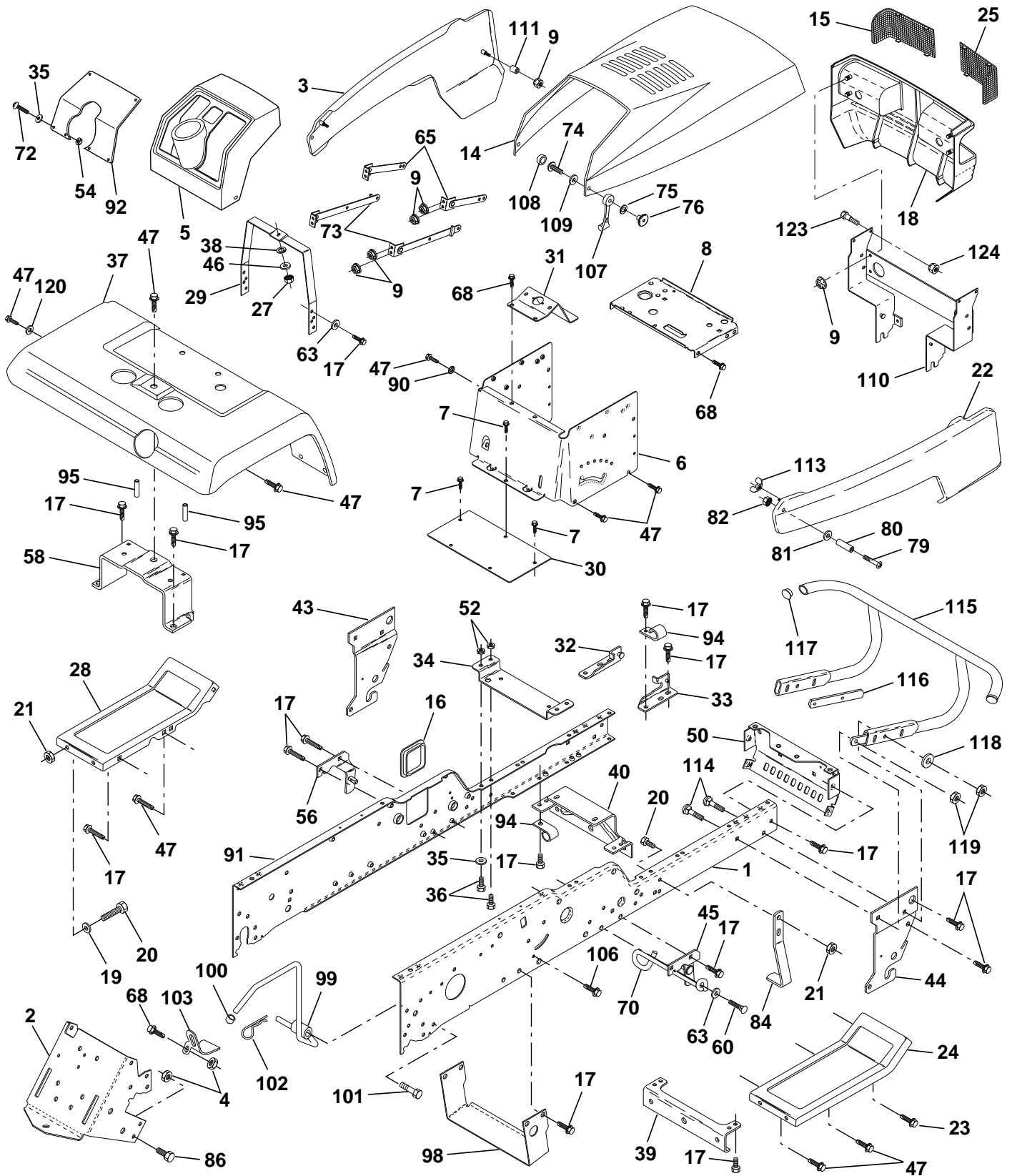

REPAIR PARTS

TRACTOR - - MODEL NO. GTH200 (954001122VA), PRODUCT NO. 954 00 19-92

CHASSIS AND ENCLOSURES

KEY NO.	PART NO.	DESCRIPTION	KEY NO.	PART NO.	DESCRIPTION
1	532144737	Rail, Frame RH	65	532104618	Strap, Asm. Hinge Front
2	532140506	Drawbar, Gt	68	817490508	Screw Thdrol. 5/16-18 x 1/2
3	532143364	Panel Asm., Side LH	70	532137159	Guide, Belt Mid Span
4	873800700	Nut, Lock Hex 7/16 Unc	72	874180512	Screw, Mach Trhd 5/16-18 x 3/4
5	532140452	Dash, Plastic Black	73	532106784	Strap, Asm. Hinge Rear
6	532145053	Dash Asm., Lower	74	874191008	Screw, Machine #10-24
7	817720408	Screw, Thd Cut 1/4-20 x 1/2	75	810071000	Washer, Lock #10
8	532145166	Support, Battery	76	532125004	Nut, Weld #10-24
14	532125454	Hood Asm., Pnt	79	874981020	Screw, Machine #10-24 x 1/4
15	532124250	Lens Headlight LH	80	532007206	Spacer, Split
16	532121794	Cover, Access	81	819070818	Washer 7/32 x 1/2 x 18 Ga.
17	817490612	Screw, Thdrol 3/8-16 x 3/4	82	873731000	Nut #10-24
18	532127325	Grille	84	532142992	Stop, Over Center Mower
19	819131312	Washer 13/32 x 13/16 x 12 Ga.	86	874760716	Bolt, Fin Hex 7/16-14 Unc x 1
20	874760616	Bolt, Fin Hex 3/8-16 x 1	90	811050600	Washer, Lock External Tooth 3/8
21	873680600	Nut, Crownlock 3/8-16	91	532144735	Rail, Frame Lh
22	532143365	Panel Asm., Side RH	92	532141626	Plate, Silkscreen Dash
24	532147202	Footrest, RH	94	532100207	Clip, Fuel Line
25	532124251	Lens, Headlight RH	95	532105531	Push Nut, Nylon
27	873220400	Nut, Fin Hex 1/4-20	98	532140503	Bracket Chassis Skid
28	532147203	Footrest, LH	99	532140871	Rod Asm. Bypass
29	532145205	Bracket, Support Dash	100	532071673	Cap Brake Parking Black
30	532145052	Saddle	101	817490628	Screw Thdrol. 3/8-16 x 1-3/4
31	532145183	Brace, Support Steering	102	532124788	Retainer Spring
32	532141315	Bracket Asm., Frame Pivot Lh	103	532142273	Bracket Lock Bypass
33	532141314	Bracket Asm., Frame Pivot Rh	106	532138776	Screw Thdrol Hex Head Zinc MWR
34	532142131	Bracket, Engine Support Rear	107	532109808	Latch, Chute Blk
35	819111116	Washer 11/32 x 11/16 x 16 Ga.	108	532110356	Cap, Snap Black
36	874780512	Bolt, Fin Hex 5/16-18 x 3/4	109	532110357	Cap, Washer Snap
37	532141449	Fender, Pnt.	110	532140625	Support Asm. Grille
38	810040400	Washer, Lock 1/4	111	532127316	Spacer
39	532136961	Bracket, Axle Front	113	532123198	Nut, Plastic Locking Wing 1/4-20
40	532142132	Bracket, Support Axle/Engine	114	872140610	Bolt, Carriage 3/8-16 x 1-1/4
43	532136939	Bracket, Spnsn Front Lh	115	532141460	Bumper Asm. W/Poly Bag
44	532136940	Bracket, Spnsn Front Rh	116	532141461	Bracket, Extension Bumper
45	532138460	Bracket Asm., Susp Chassis Rh	117	532143679	Plug Plastic
46	819091216	Washer 9/32 x 3/4 x 16 Ga.	118	819131316	Washer 13/32 x 13/16 x 16 Ga.
47	817490608	Screw Thdrol 3/8-16 x 1/2	119	873680600	Nut, Crownlock 3/8-16 UNC
50	532136575	Bracket, Chassis Front	120	819131616	Washer 13/32 x 1 x 16 Ga.
52	873680500	Nut, Crownlock 5/16-18	123	532123481	Bolt, Shoulder 1/4-20
54	873510500	Nut 5/16-18	124	873800400	Nut Crownlock 1/4-20
56	532138461	Bracket Asm., Susp Chassis Lh	--	532125085	Plug, Hole
57	532108067	Nut, Pal			
58	532137113	Bracket Asm., Fender			
60	817490620	Screw Thdrol 3/8-16 x 1-1/4			
63	819131614	Washer 13/32 x 1 x 14 Ga.			

NOTE: All component dimensions given in U.S. inches
1 inch = 25.4 mm

REPAIR PARTS

TRACTOR - - MODEL NO. GTH200 (954001122VA), PRODUCT NO. 954 00 19-92
GROUND DRIVE

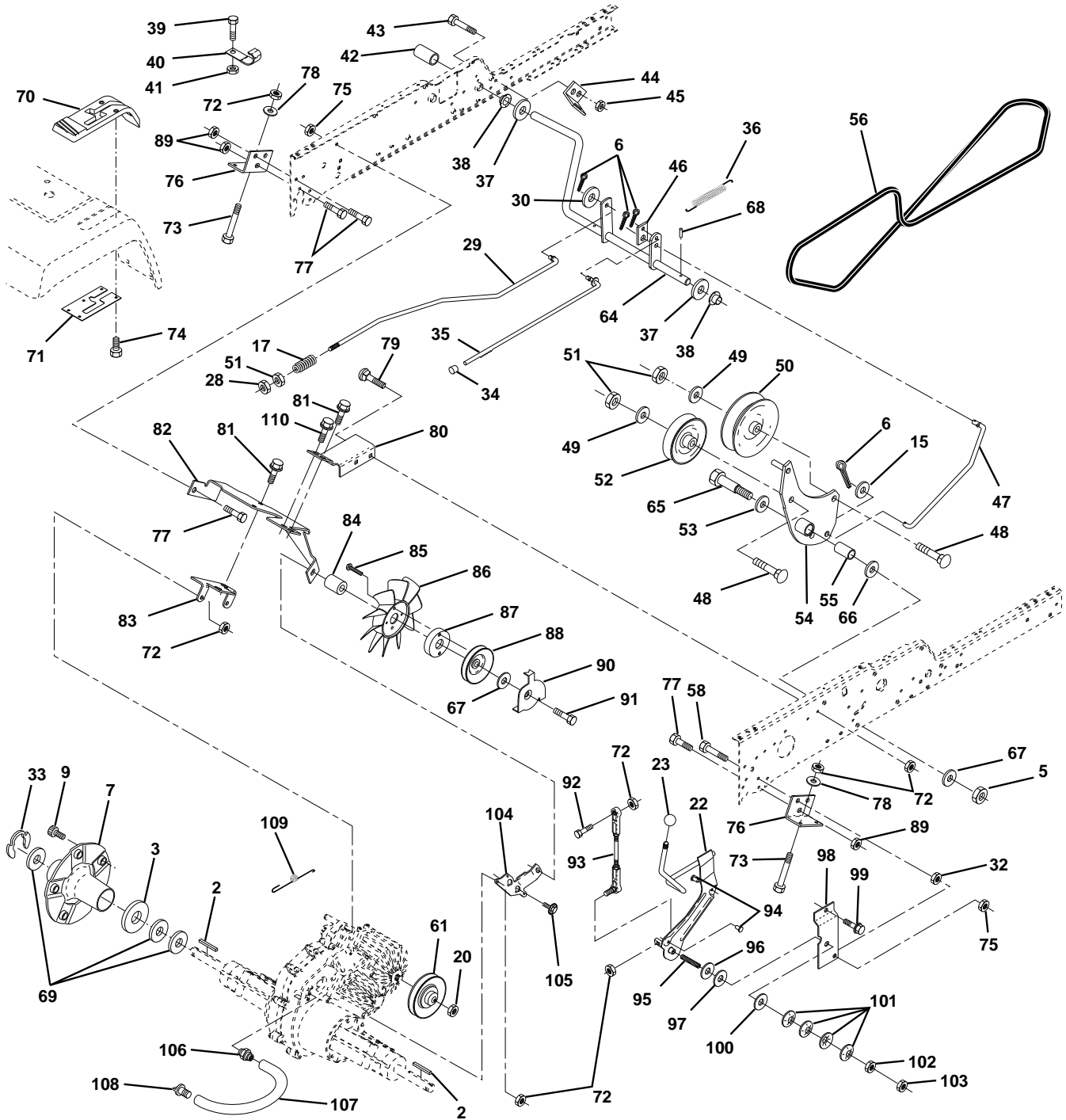

REPAIR PARTS

TRACTOR - - MODEL NO. GTH200 (954001122VA), PRODUCT NO. 954 00 19-92

GROUND DRIVE

KEY NO.	PART NO.	DESCRIPTION	KEY NO.	PART NO.	DESCRIPTION
2	532007070	Key 1/4 x 2.5	69	532123800	Washer
3	532007563	Washer Thrust Axle Harden	70	532139989	Console Hydro Fender
5	873680600	Nut Crownlock 3/8-16	71	532140927	Plate Console Shift
6	876020412	Pin Cotter 1/8 x 3/4	72	873680500	Nut Crownlock 5/16-18
7	532140507	Wheel Hub Asm.	73	874780548	Bolt Fin Hex 5/16-18 x 3
9	532140080	Bolt Hub	74	532142432	Screw, Hex Wsh Hi-Lo 1/4-1/2
15	819131316	Washer 13/32 x 13/16 x 16 Ga.	75	873800700	Nut Lock Hex 7/16
17	532140921	Spring Rod Brake	76	532140481	Bracket Transaxle
20	873940800	Nut Hex Jam Toplock 1/2-20	77	874760716	Bolt Fin Hex 7/16-14 x 1
22	532140498	Shaft Arm Asm	78	819111212	Washer 11/32 x 3/4 x 12 Ga.
23	532140845	Knob	79	872110505	Bolt Carriage 5/16-18 x 5/8
28	873350600	Nut, Hex Jam 3/8-16	80	532140484	Bracket Torque RH
29	532140494	Brake Rod	81	817490612	Screw Thdrol 3/8-16 x 3/4
30	819131616	Washer 13/32 x 1 x 16 Ga	82	532140482	Bracket Mount Torque/Fan
32	873220700	Nut Hex 7/16-14	83	532140479	Strap Torque Mid
33	812000053	Ring E	84	532140490	Spacer
34	532124236	Cap Plunger	85	817541020	Screw #10-24 x 1-1/4
35	532137648	Rod Parking Brake	86	532140462	Fan 7" Hydro
36	532138364	Spring Extension	87	532140491	Adapter Fan
37	532121749	Washer 25/32 x 1-1/4 x 16 Ga.	88	532140492	Pulley Idler
38	532110895	Nyliner	89	873680700	Nut, Crownlock 7/16-14
39	874321016	Screw Fin #10-24 x 1	90	532140489	Keeper Belt
40	532005304	Actuator Interlock Switch	91	817490644	Screw Thdrol 3/8-16 x 2-3/4
41	873631000	Nut Lock #10-24	92	874760520	Bolt Fin Hex 5/16-18 x 1.75
42	532123533	Cover Pedal	93	532140502	Link Shift Asm
43	874760412	Bolt Hex Head 1/4-20 x 3/4	94	532133835	Fastner Christmas Tree
44	532104601	Bracket Interlock	95	823200528	Screw Set 5/16-18 x 1.75
45	873800400	Nut Lock W/Insert 1/4-20	96	532141103	Washer Nickel Plated
46	532145170	Retainer Spring	97	532126874	Bearing Trust
47	532138228	Clutch Rod	98	532141004	Bracket Shift
48	872110614	Bolt Carriage 3/8-16 x 1-3/4 Gr. 5	99	817490624	Screw Thdrol 3/8-16 x 1-1/2
49	819131413	Washer 13/32 x 7/8 x 13 Ga	100	532126881	Washer Compression
50	532131494	Pulley Idler Flat	101	532059285	Washer Bellville
51	873680600	Nut Crownlock 3/8-16 UNC	102	873560500	Nut Hex Nylok
52	532139123	Pulley Idler Grooved	103	873350500	Nut Hex Jam 5/16-18
53	532000207	Washer Hardened	104	532140480	Bracket Idler
54	532138390	Clutch Arm Asm	105	817580408	Screw Tap 1/4-20 x 1/2
55	532105706	Bearing, Idler	106	532142576	Fitting Vent Hose
56	532140218	V-Belt	107	532142577	Vent Hose
58	874760724	Bolt Fin Hex 7/16-14 x 1-1/2	108	532142578	Cap Vent
61	532140488	Pullery Transaxle	109	532140929	Spring Return Brake
64	532137649	Shaft Asm Brake Parking Clutch	110	532088652	Screw, Hinge
65	532067609	Bolt Shoulder	--	532140343	Transaxle Hydro
66	532140296	Washer Hardened			
67	819131312	Washer 13/32 x 13/16 x 12 Ga			
68	532005142	Pin Roll			

NOTE: All component dimensions given in U.S. inches
1 inch = 25.4 mm

REPAIR PARTS

TRACTOR - - MODEL NO. GTH200 (954001122VA), PRODUCT NO. 954 00 19-92
STEERING ASSEMBLY

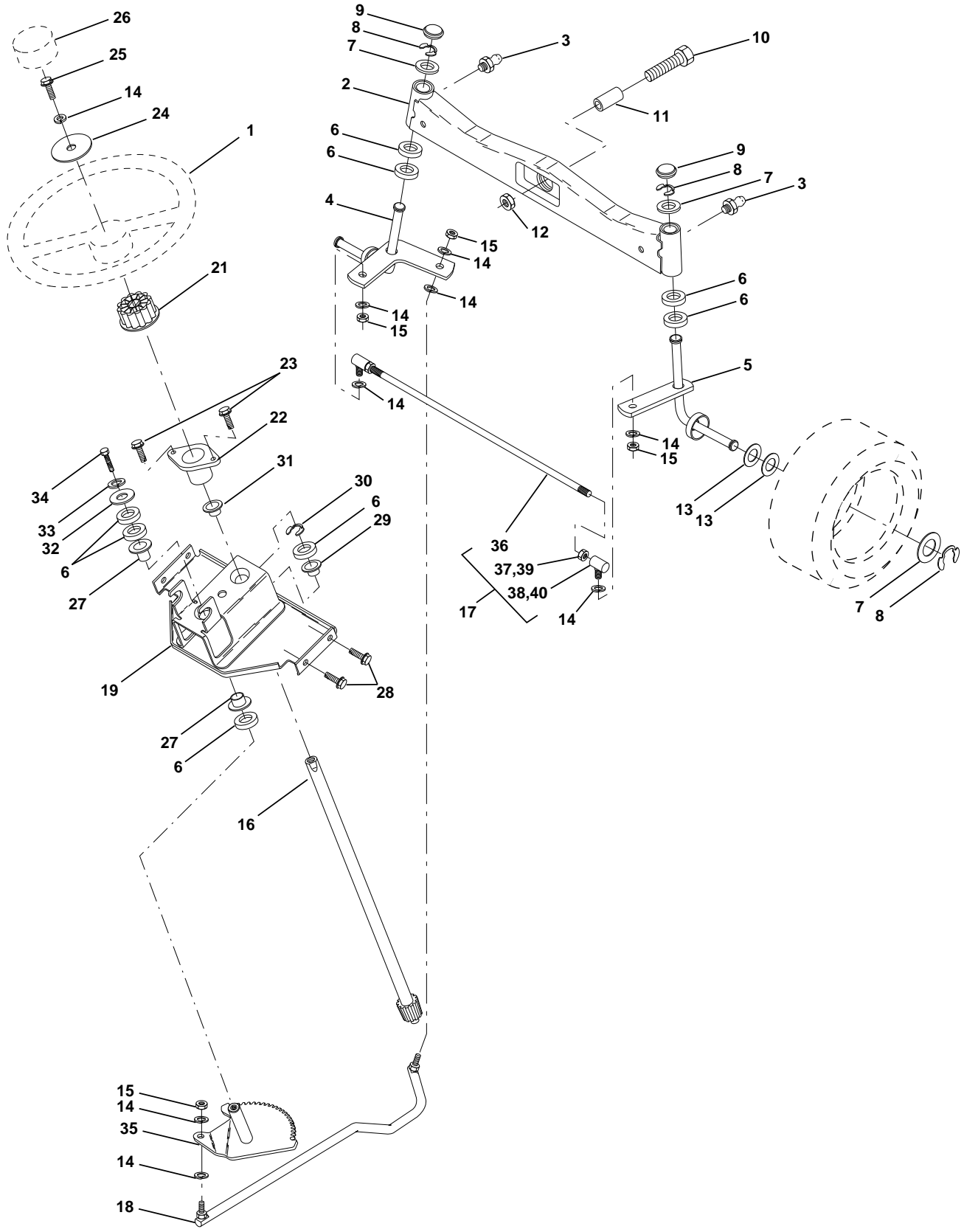

REPAIR PARTS

TRACTOR - - MODEL NO. GTH200 (954001122VA), PRODUCT NO. 954 00 19-92 STEERING ASSEMBLY

KEY NO.	PART NO.	DESCRIPTION
1	532124415	Wheel, Steering
2	532137094	Axle Asm., Front
3	532124836	Fitting, Grease
4	532136960	Spindle Asm, LH
5	532136959	Spindle Asm., RH
6	532124956	Bearing, Race Thrust Harden
7	532121748	Washer 25/32 x 1-5/8 x 16 Ga.
8	812000029	Ring, Klip #T5304-75
9	532121232	Cap, Spindle
10	874781044	Bolt, Fin Hex 5/8-11 x 2-3/4
11	532136518	Spacer, Brg. Axle Front
12	873901000	Nut, Lock Flange 5/8-11 Unc
13	532121749	Washer 25/32 x 1-1/4 x 16 Ga.
14	810040600	Washer, Lock Hvy Hlcl Spr 3/8
15	873610600	Nut, Fin Hex 3/8-24 Unf
16	532145103	Shaft Asm., Steering
17	532137347	Rod Asm., Tie Ball J Ball Vgt (Inc. Key No. 36-40)
18	532137155	Draglink, Ball Joint Solid Vgt
19	532146611	Support Asm., Steering Vgt
21	532100711	Adapter, Wheel Steering
22	532124720	Bushing, Strg. Blk
23	817431008	Screw, Slftp #10-16 x 1/2 Ty-b
24	819133808	Washer 13/32 x 2-3/8 x 8 Ga.
25	874780616	Bolt, Fin Hex 3/8-16 x 1 Gr. 5
26	532124416	Cap, Wheel Steering
27	532124937	Bearing, Col. Strg.
28	817490612	Screw, Thdrol. 3/8-16 x 3/4 Ty-TT
29	532104239	Bearing, Flange
30	812000034	Ring, Klip Truarc #5304-75
31	532138136	Bushing, Nyliner Snap
32	819111610	Washer 11/32 x 1 x 10 Ga.
33	810040500	Washer, Lock Hvy Hlcl Spr 5/16
34	874760512	Bolt, Hex Hd 5/16-18 x 3/4
35	532138059	Gear, Sector Steering
36	532137156	Tie Rod
37	873360600	Jam Nut RH Thread
38	532109850	Joint Asm. Ball RH Thread
39	873700600	Jam Nut LH Thread
40	532109851	Joint Asm. Ball LH Thread

NOTE: All component dimensions given in U.S. inches
1 inch = 25.4 mm

REPAIR PARTS

TRACTOR - - MODEL NO. GTH200 (954001122VA), PRODUCT NO. 954 00 19-92
ENGINE

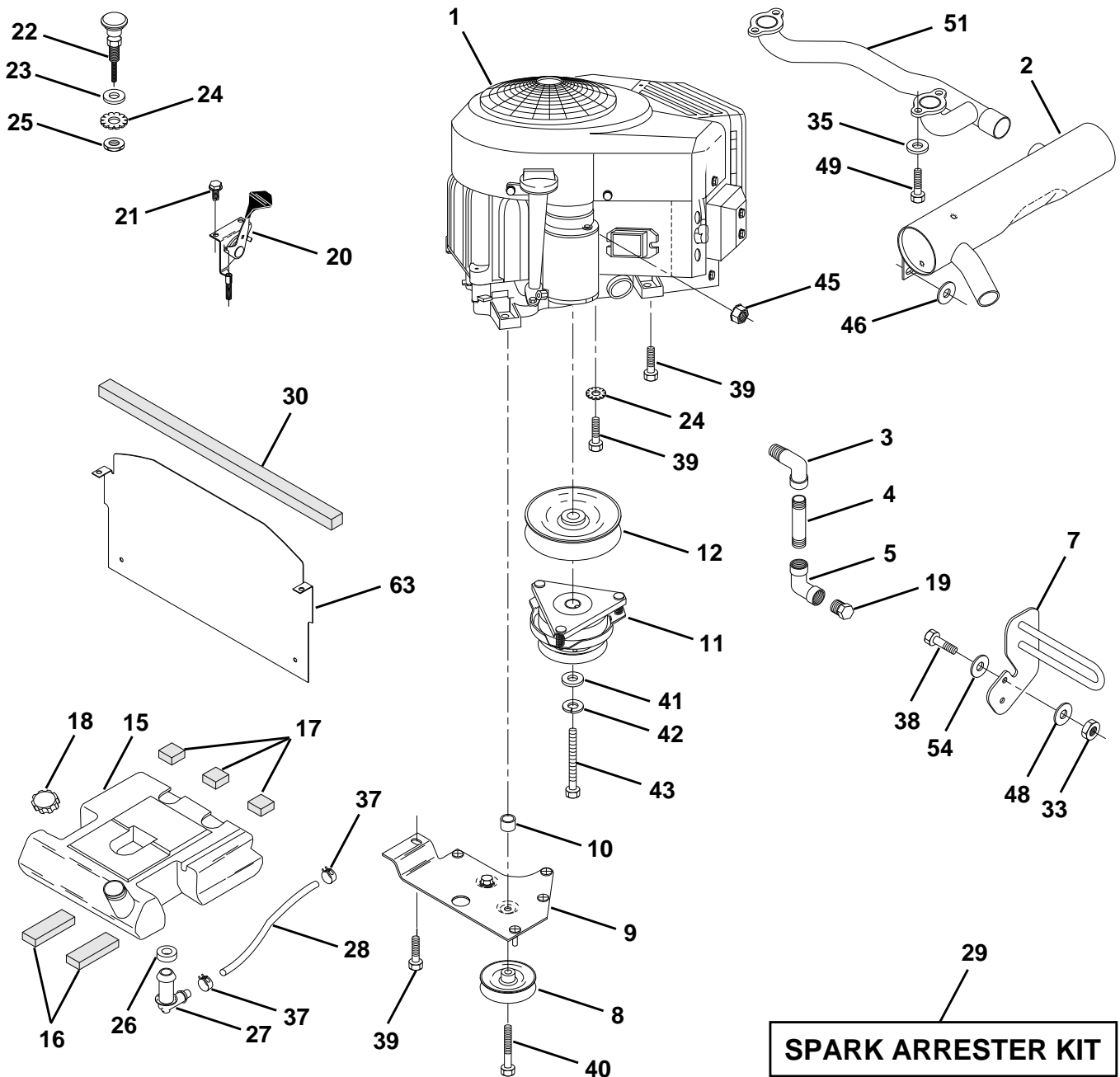

REPAIR PARTS

TRACTOR - - MODEL NO. GTH200 (954001122VA), PRODUCT NO. 954 00 19-92

ENGINE

KEY NO.	PART NO.	DESCRIPTION
1	-----	Engine B&S, Model No. 351777
2	532144636	Muffler VGT Cylinder
3	813240300	Elbow Street 3/8 NPT
4	813280328	Nipple Pipe 3/8NPT X 3 - 1/2
5	813200300	Elbow STD 90 Degree 3/8 - 18 NPT
7	532143599	Muffle Asm. Guard
8	532121361	Pulley V-Idler
9	532145109	Stop Keeper Asm VGT
10	532105432	Bushing
11	532137140	Clutch Electric
12	532136907	Pulley Engine VGT Elect Clutch
15	532141070	Tank Fuel W/Sym Vented
16	532109227	Pad Spacer
17	532106082	Pad Spacer
18	532140527	Cap Asm Fuel W/Sym Vented
19	813290300	Plug Oil Drain (Order From Engine Manufacturer)
20	532132747	Control Throttle
21	817720410	Screw Hex Thd Cut 1/4 - 20 X 5/8
22	532132782	Control Choke
23	819131316	Washer 13/32 x 13/16 x 16 Ga.
24	811050600	Washer Ext Tooth 3/8
25	873610600	Nut Fin Hex 3/8 - 24 UNF
26	532124952	Bushing
27	532139277	Stem Tank Fuel
28	532124703	Fuel Line
29	532132920	Spark Arrester Kit
30	532105037	Strip Foam
33	873800600	Nut Lock Hex w/Ins 3/8 - 16
35	810040500	Washer Lock Hvy HLCL Spr 5/16
37	532123487	Clamp Hose
38	874780624	Bolt Fin Hex 3/8 - 16 x 1-1/2
39	817490624	Screw Thdrol 3/8 - 16 X 1 - 1/2 TT
40	817490652	Screw Thdrol 3/8 - 16 X 3 - 1/4
41	532126197	Washer 1-1/2 OD X 15/32 ID X .250
42	810040700	Washer Lock 7/16
43	871170768	Bolt Hex 7/16-20 X 4-1/4 Ga 5
45	873510400	Nut Keps Hex 1/4-20 UNC
46	819131616	Washer 13/32 x 1 x 16 Ga.
48	819132007	Washer 13/32 x 1-1/4 x 7 Ga.
49	532144476	Bolt Socket Hd 8 x 1.25 x 20 mm
51	532140805	Pipe Exhaust
54	819131414	Washer Flat 13/32 x 7/8 x 14 Ga.
63	532141947	Shield, Heat VGT HUSQ/Vanguard

NOTE: All component dimensions given in U.S. inches
1 inch = 25.4 mm

REPAIR PARTS

TRACTOR - - MODEL NO. GTH200 (954001122VA), PRODUCT NO. 954 00 19-92

SEAT ASSEMBLY

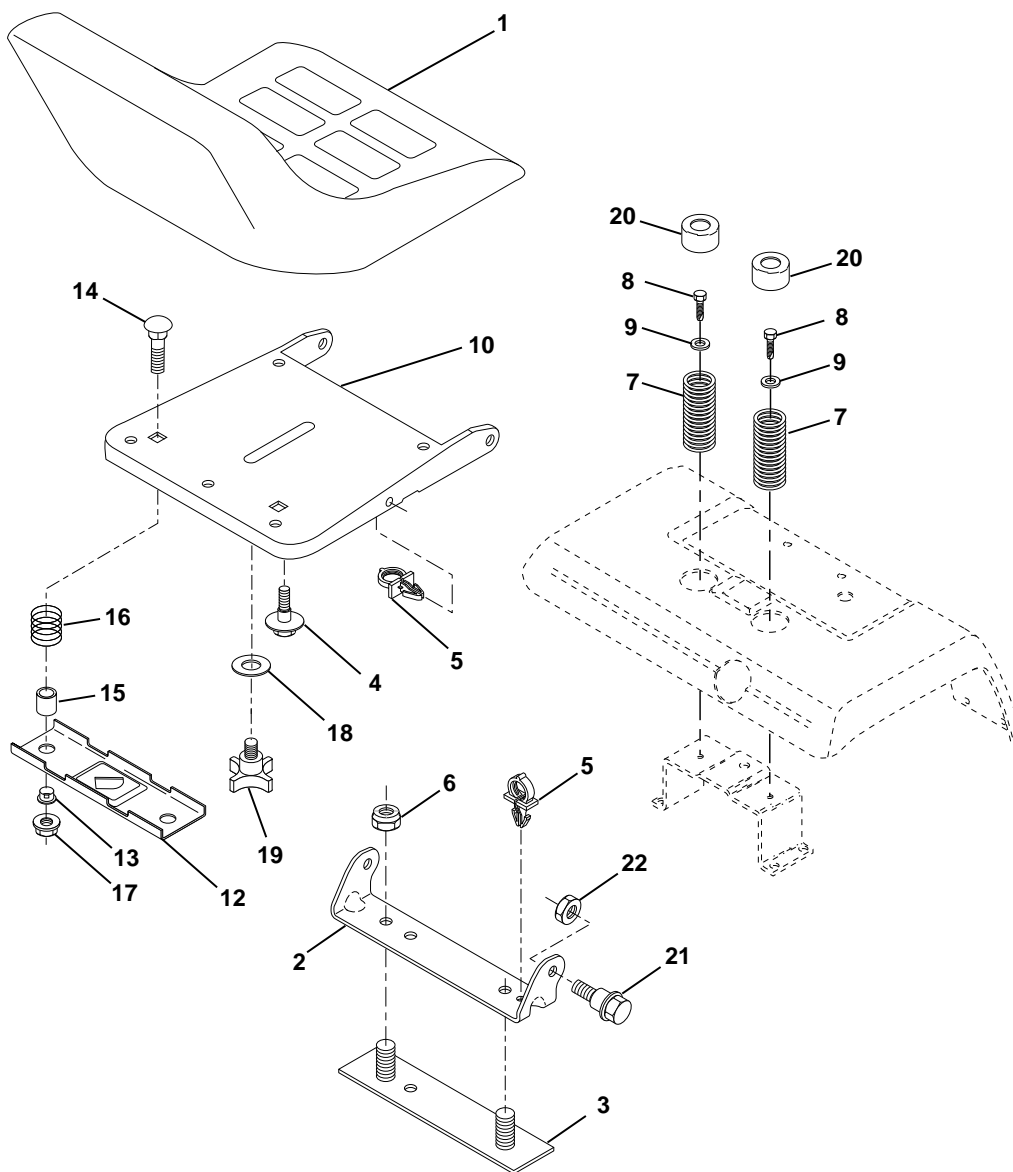

KEY NO.	PART NO.	DESCRIPTION
1	532141525	Seat
2	532140551	Bracket, Pivot Seat
3	532140675	Strap, Fender
4	532127018	Bolt, Shoulder 5/16-18 X .62
5	532145006	Clip, Push In Hinged
6	873800600	Locknut 3/8-16 Unc
7	532124181	Spring, Seat Cprsn
8	817490508	Screw, Thdrol 5/16-18 X 1/2
9	819131614	Washer 13/32 X 1 X 14 Ga.
10	532140552	Pan, Seat
12	532121246	Bracket, Mounting Switch
13	532121248	Bushing, Snap

KEY NO.	PART NO.	DESCRIPTION
14	872050411	Bolt, Carriage 1/4-20 X 1-3/8
15	532121249	Spacer, Split
16	532123740	Spring, Cprsn
17	532123976	Nut, Lock 1/4 Lge Flg Gr. 5
18	819171912	Washer 17/32 X 1-3/16 X 12 Ga.
19	532120068	Knob, Seat 1/2-13 Unc
20	532124238	Cap, Spring Seat
21	532139888	Bolt, Shoulder 5/16-18 Unc
22	873680500	Nut, Crownlock 5/16-18 Unc

NOTE: All component dimensions given in U.S. inches
1 inch = 25.4 mm

REPAIR PARTS

TRACTOR -- MODEL NO. GTH200 (954001122VA), PRODUCT NO. 954 00 19-92

LIFT ASSEMBLY

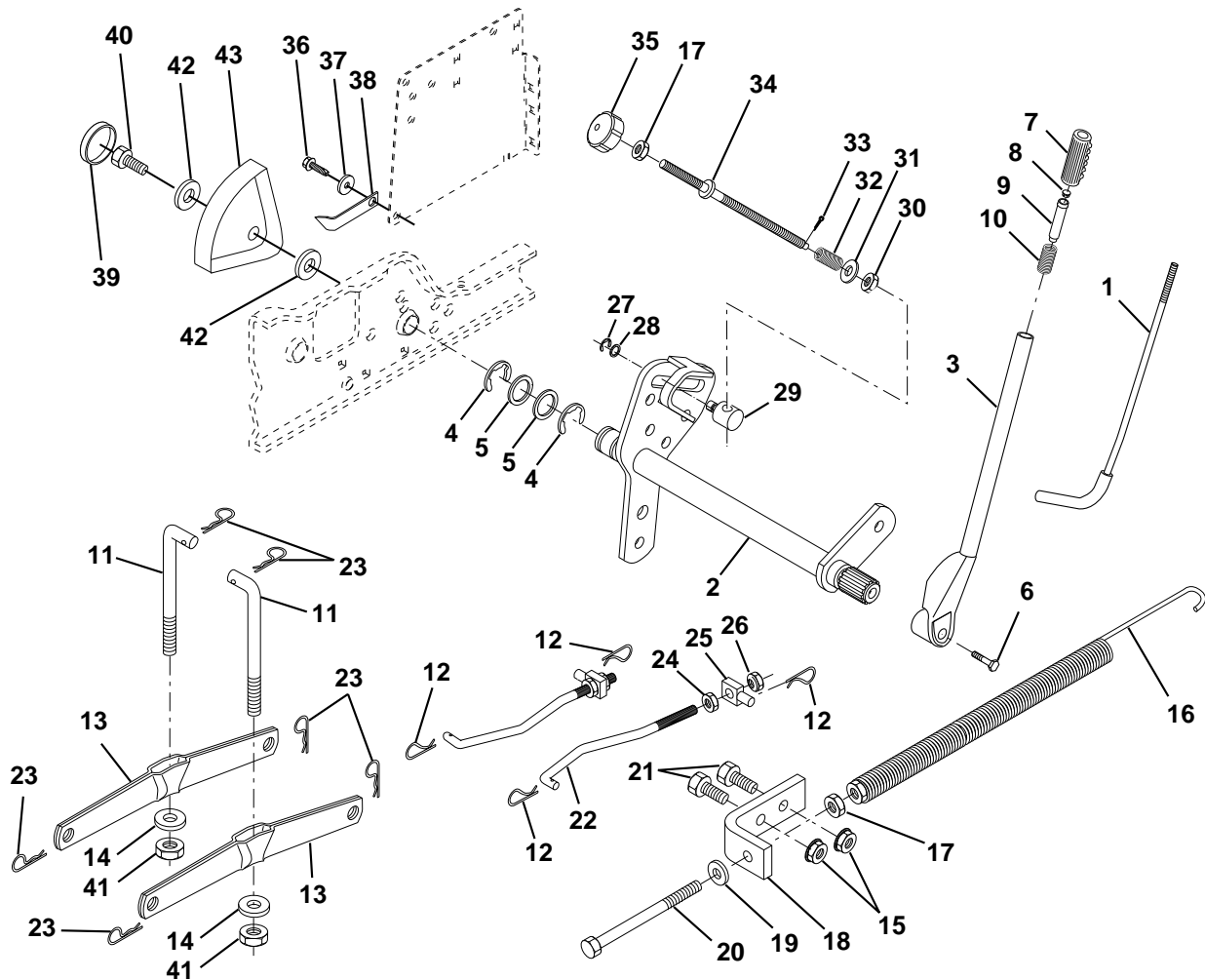

KEY NO.	PART NO.	DESCRIPTION	KEY NO.	PART NO.	DESCRIPTION
1	532121006	Rod Asm., Lever	24	873350800	Nut, Jam Hex 1/2-13 Unc
2	532145542	Shaft Asm., Lift Vgt	25	532130171	Trunnion
3	532121002	Lever Asm., Lift Rh	26	873800800	Nut, Lock W/Wsh 1/2-13 Unc
4	812000022	E-Ring Truarc #5133-87	27	812000037	Ring, Klip #T5304-37
5	819292016	Washer 29/32 x 1-1/4 x 16 Ga.	28	819151216	Washer 15/32 x 3/4 x 16 Ga.
6	874780624	Bolt, Fin Hex 3/8-16 x 1-1/2	29	532110810	Trunnion, Dp Stop Dbl Thds Plt
7	532125631	Grip, Handle Fluted	30	532110807	Nut, Special
8	532124526	Button, Plunger	31	819131016	Washer 13/32 x 5/8 x 16 Ga.
9	532122364	Plunger, Lever Lift	32	532137150	Spring, Compression Inf Hgt
10	532124874	Spring 2-1/8"	33	876020308	Pin, Cotter 3/32 x 1/2
11	532146704	Link Lift	34	532137167	Rod, Adj Lift
12	532124660	Retainer, Spring	35	532138057	Knob, Inf 3/8-16 Unc
13	532139868	Arm, Suspension Vgt	36	817490612	Screw, Thdrol 3/8-16 x 3/4
14	532140302	Bearing	37	532120529	Washer, Nylon
15	873680600	Nut, Crownlock 3/8-16 Unc	38	532138346	Pointer, Nrlt Height Indicator
16	532124687	Spring Asm., Assist Lift	39	532123935	Plug, Hole
17	873350600	Nut, Hex Jam 3/8-16 Unc	40	817490512	Screw, Thdrol 5/16-18 x 3/4 TYT
18	532143363	Bracket, Spring Assist	41	873540600	Nut, Crownlock 3/8-24
19	819131316	Washer 13/32 x 13/16 x 16 Ga.	42	819112410	Washer 11/32 x 1-1/2 x 10 Ga.
20	532005328	Bolt, Adjust Spring Assist	43	532123934	Scale, Indicator Height
21	874760616	Bolt, Fin Hex 3/8-16 x 1			
22	532127218	Link, Front			
23	532124670	Retainer, Spring			

NOTE: All component dimensions given in U.S. inches
1 inch = 25.4 mm

REPAIR PARTS

TRACTOR - - MODEL NO. GTH200 (954001122VA), PRODUCT NO. 954 00 19-92
MOWER DECK

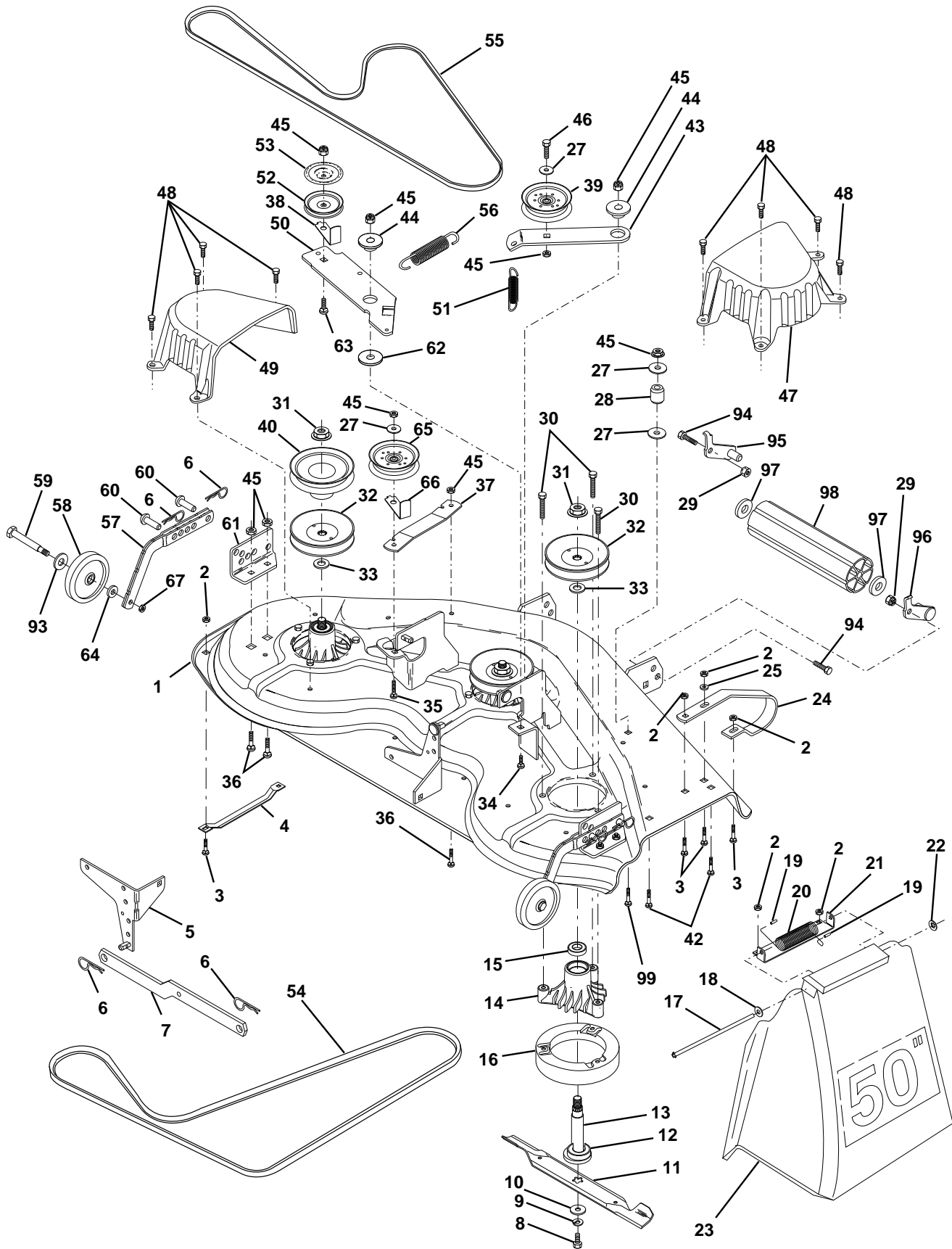

REPAIR PARTS

TRACTOR - - MODEL NO. GTH200 (954001122VA), PRODUCT NO. 954 00 19-92

MOWER DECK

KEY NO.	PART NO.	DESCRIPTION	KEY NO.	PART NO.	DESCRIPTION
1	532136457	Deck Asm., Mower 50" Vented	43	532136460	Arm, Idler Secondary
2	873680500	Nut, Crownlock 5/16-18	44	532122052	Spacer, Retainer
3	872110506	Bolt, Carriage 5/16-18 x 3/4	45	873680600	Nut, Crownlock 3/8-16 Unc
4	532125074	Runner, Mower LH	46	874760628	Bolt, Fin Hex 3/8-16 Unc x 1-3/4
5	532138457	Bracket Asm., Sway Bar	47	532137200	Cover, Mandrel RH
6	532124670	Retainer, Spring	48	532137729	Screw, Thd Roll 1/4-20 x 5/8
7	532130832	Arm Suspension, Rear	49	532136574	Cover, Mandrel LH
8	532850857	Bolt 3/8-24 x 1.25 Gr. 8 Patched	50	532137272	Arm, Idler Primary
9	810030600	Washer, Lock Hvy 3/8 Unplated	51	532137273	Spring, Secondary
10	532140296	Washer, Hard Blade Mower Vented	52	532139245	Pulley, Idler V Groove
11	532137380	Blade (3 Required)	53	532137789	Shield, Idler
12	532129895	Bearing, Ball #6204 (Mandrel)	54	532139573	V-Belt, Mower Primary
13	532137553	Shaft Asm., W/Lower Brg (Includes Key No. 12)	55	532144959	V-Belt, Mower Secondary
14	532137152	Housing, Mandrel 50" Vent	56	532138687	Spring, Primary
15	532110485	Bearing, Ball Mandrel	57	532136577	Bar Asm., Wheel Gauge
16	532140329	Stripper, Mower Round	58	532105455	Wheel, Gauge
17	532106735	Rod, Hinge	59	532124842	Bolt, Shoulder
18	819111016	Washer 11/32 x 5/8 x 16 Ga.	60	532139031	Pin, Clevis
19	532105304	Cap, Sleeve	61	532136573	Bracket, Wheel Gauge
20	532123713	Spring, Torsion Deflector	62	532133943	Washer Hardened
21	532137607	Bracket, Deflector	63	872110612	Bolt Carriage 3/8-16 x 1-1/2
22	532110452	Nut, Push	64	819121414	Washer 3/8 x 7/8 x 14 Ga.
23	532110509	Shield, Deflector Mower	65	532102403	Pulley Idler Flat Mower
24	532136320	Runner, RH	66	532139622	Keeper, Belt Idler 50" Vent
25	819111216	Washer 11/32 x 3/4 x 16 Ga.	67	873930600	Nut, Center Lock 3/8-16
27	819131316	Washer 13/32 x 13/16 x 16 Ga.	93	819171512	Washer 17/32 x 15/16 x 12 Ga.
28	532132823	Spacer, Spring Stop Idler	94	874760616	Bolt, Fin Hex 3/8-16 x 1
29	873800600	Nut, Lock Hex W/Wsh 3/8-16 Unc	95	532132274	Bracket, Asm. Noseroller LH
30	532138776	Screw Thdrol Hex Head	96	532132273	Bracket, Asm. Noseroller RH
31	532137266	Nut, Flg Top Lock Cntr 9/16	97	819171416	Washer 17/32 x 7/8 x 16 Ga.
32	532129861	Pulley, Mandrel	98	532132264	Roller, Nose
33	532129963	Washer, Spacer Mower Vented	99	872110614	Bolt, Carriage 3/8-16 x 1-3/4 Gr. 5
34	872140610	Bolt, Carriage 3/8-16 x 1-1/4	--	532143651	Mandrel Asm (Includes Key Nos. 8-10, 12-15, 31 and 33)
35	872110616	Bolt, Carriage 3/8-16 x 2	--	532141051	Mower Asm Service (Std. Deck - Order separately all Nose Roller and all Gauge Wheel components)
36	872110608	Bolt, Carriage 3/8-16 x 1 Gr. 5			
37	532137166	Stiffener, Arm Idler			
38	532137554	Keeper, Belt Idler			
39	532131494	Pulley, Idler Flat			
40	532136572	Pulley, Driven			
42	872140506	Bolt, Carriage 5/16-18 Unc x 3/4			

NOTE: All component dimensions given in U.S. inches
1 inch = 25.4 mm

REPAIR PARTS

TRACTOR - - MODEL NO. GTH200 (954001122VA), PRODUCT NO. 954 00 19-92
TRANSAXLE HYDRO GEAR MODEL NUMBER 214-3010

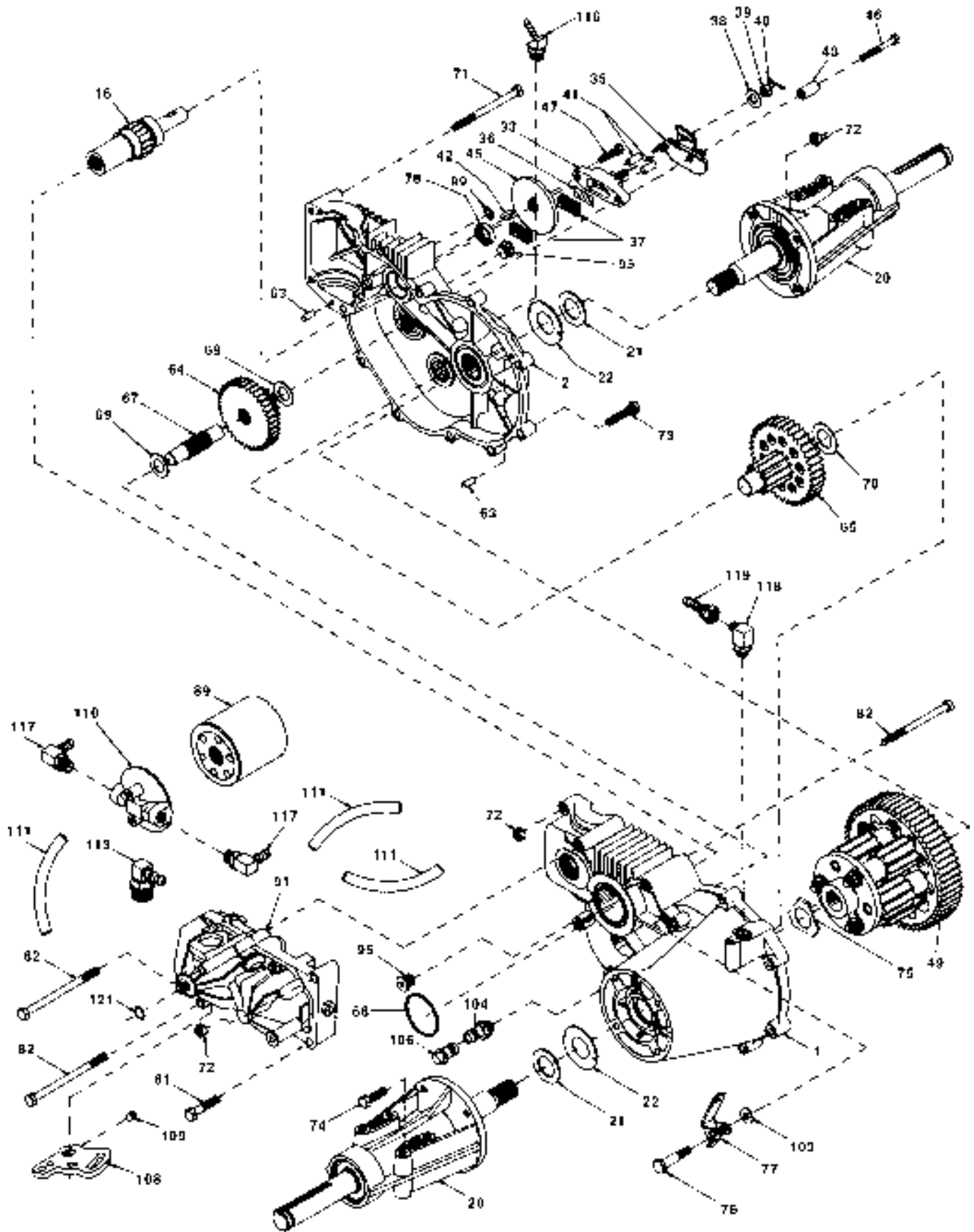

REPAIR PARTS

TRACTOR - - MODEL NO. GTH200 (954001122VA), PRODUCT NO. 954 00 19-92

TRANSAXLE HYDRO GEAR MODEL NUMBER 214-3010

ITEM NO.	AYP PART NO.	DESCRIPTION
1	532142874	Assembly, Lh Housing
2	532142875	Assembly, Rh Housing
16	532142876	Brake Shaft Assembly
20	532142877	Axle Mounting Horn Ass'y
21	532142878	Washer, 1.0x1.63x.08
22	532142879	Washer, 1.0x2.06x.09
33	532142929	Brake Yoke Assembly
35	532142880	Brake Arm
36	532142882	Puck Plate
37	532142883	Brake Puck
38	532142884	Washer, 7/8odx7/16x.060
39	532142885	Castle Nut, 5/16-24
40	532142886	Cotter Pin
41	532142887	Brake Actuating Pin
42	532142888	Hi Pro Key
43	532142889	Spacer
45	532142890	Brake Disc
46	532142891	Bolt, 1/4-20 X 1-1/2
47	532142892	Bolt, 1/4-20 X 1
49	532142893	Differential Assembly
63	532142894	Dowel Pin
64	532142896	14t-38t Reduction Gear
65	532142897	Final Drive Pinion Ass'y
67	532142898	Jack Shaft
68	532142899	O Ring
69	532142900	Washer, 5/8 X 1-5/32
70	532142901	Washer, 7/8 X 1-1/2
71	532142902	Bolt, Hex 5/16-18 X 3.5
72	532142903	Hex Lock Nut, 5/16-18
73	532142904	Bolt, Hex 5/16-18 X 1-1/2
74	532142905	Hex Cap Screw, 5/16-18 X 1
75	532142906	Washer, Differential
76	532142907	Shoulder Bolt
77	532142908	Freewheel Actuating Arm
78	532142909	Oil Seal, .625 X 1.0 X .25
81	532142910	Bolt, Hex 5/16-18 X 1-3/4
82	532142911	Bolt, 5/16-18 X 4-1/2
89	532142912	Spin On Filter
91	532142913	Bdu-10l-118
95	532142914	Straight Thread Plug
99	532142915	Washer, 11/32 X 9/16
103	532142916	Washer
104	532142917	Cap-Vent Assembly
106	532142918	Fitting-O Ring Assembly
108	532142919	Control Arm
109	532142920	Set Screw
110	532142921	Filter Head
111	532142922	Hose, 5/16 X 12" Long
113	532142923	90° 7/8 Sae Fitting
116	532142924	45° 9/16 Sae Fitting
117	532142925	90° 9/16 Sae Fitting
118	532142926	90° Sae #6 Flare Male Fitting
119	532142927	90° Sae #6 Flare Female Fitting
121	532142928	Wire Retaining Ring

REPAIR PARTS

TRACTOR - - MODEL NO. GTH200 (954001122VA), PRODUCT NO. 954 00 19-92

TRANSAXLE PUMP - - MODEL NUMBER BDU-10L-118

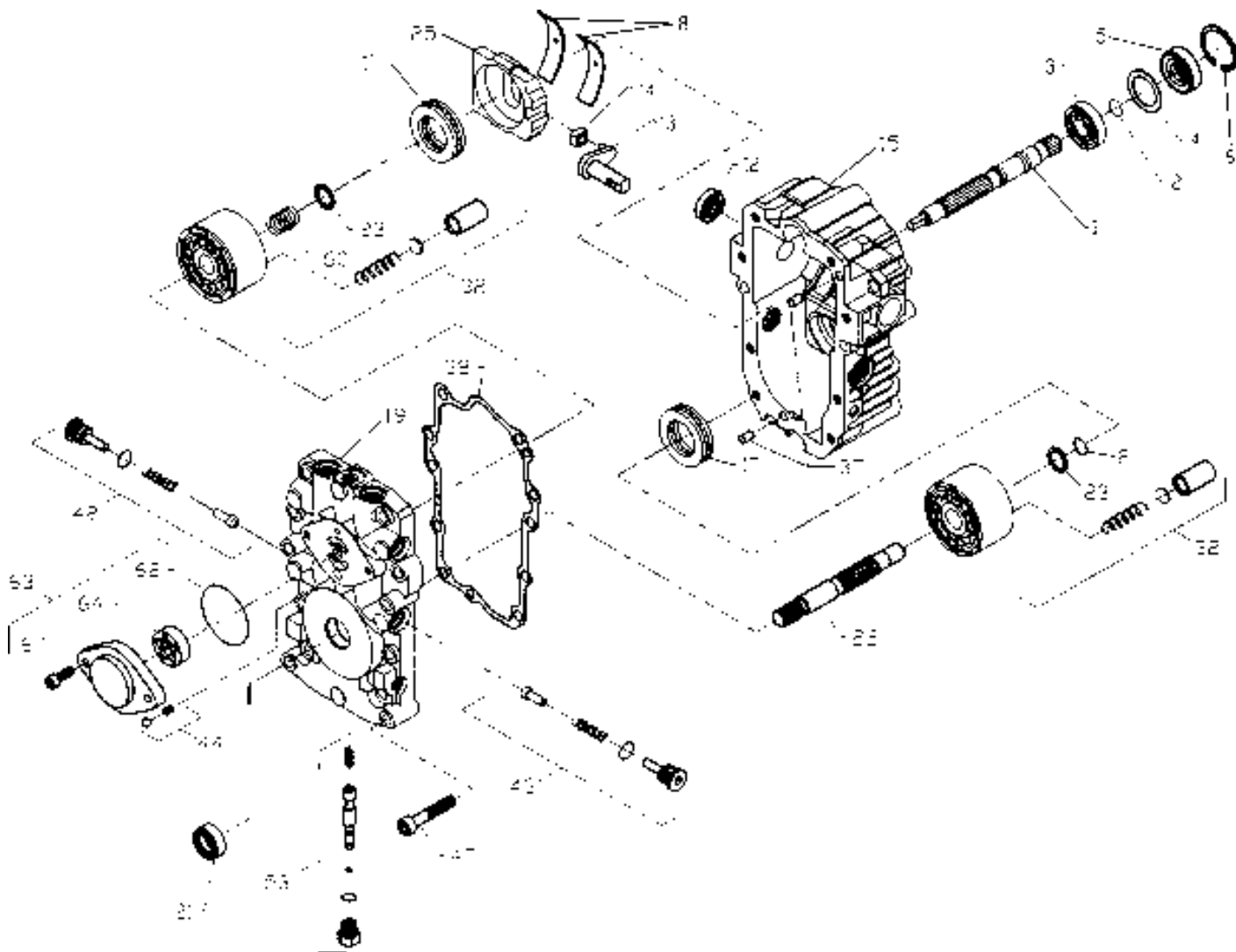

KEY PART NO. NO.

DESCRIPTION

1	532144569	Shaft, Pump
2	532122716	Ring, Retaining
3	532122745	Bearing, Ball
4	532122715	Spacer
5	532122700	Seal, Lip
6	532122699	Ring, Retaining
8	532122767	Bearing, Cradle
12	532122717	Seal, Lip
13	532122748	Arm, Trunnion
14	532122749	Guide, Slot
15	532144571	Housing Kit, Transmission
17	532122770	Bearing, Thrust, Ball
19	532144572	Center Section Kit
21	532122722	Seal, Lip
22	532144573	Shaft, Motor
23	532144574	Washer, Block Thrust

KEY PART NO. NO.

DESCRIPTION

25	532127148	Swashplate, Variable
32	532144577	Block Assembly
37	532122786	Pin, Stainless, Headless
38	532122718	Gasket, Center Section
42	532144578	Check Valve Kit
43	532144578	Check Valve Kit
44	532144579	Charge Relief Kit
47	532122752	Screw, Socket Head, Cap
53	532127153	Bypass Valve Kit
60	532144580	Block Spring
62	532144581	O-Ring
63	532144582	Charge Pump Kit
64	532144583	Gerotor Assembly
67	532144584	Screw, Socket Head, Cap
--	532144576	Pump Assembly, Complete