

GTH 200

954002022A

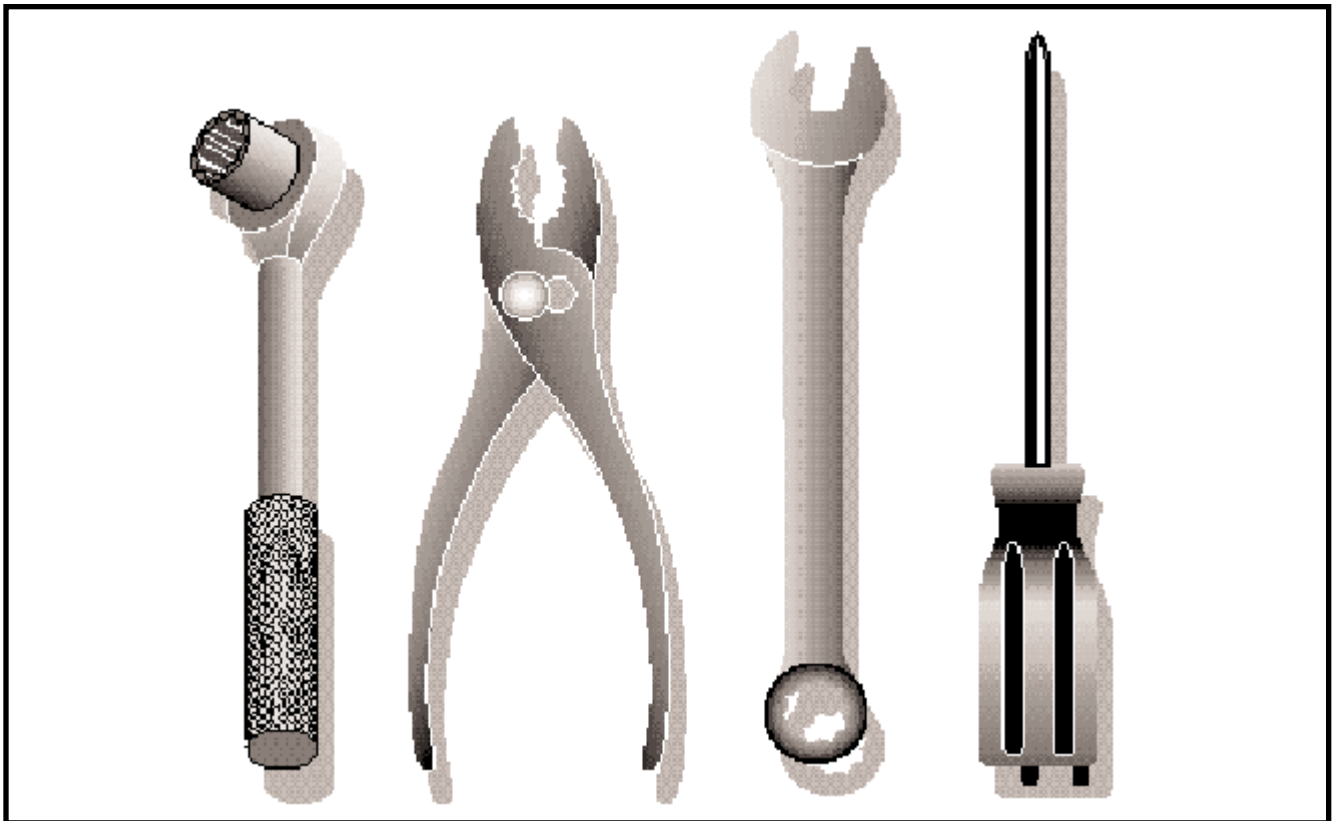

Repair Parts Manual

Ride Mower

TRACTOR - - MODEL NO. GTH200 (954002022A)

SCHEMATIC

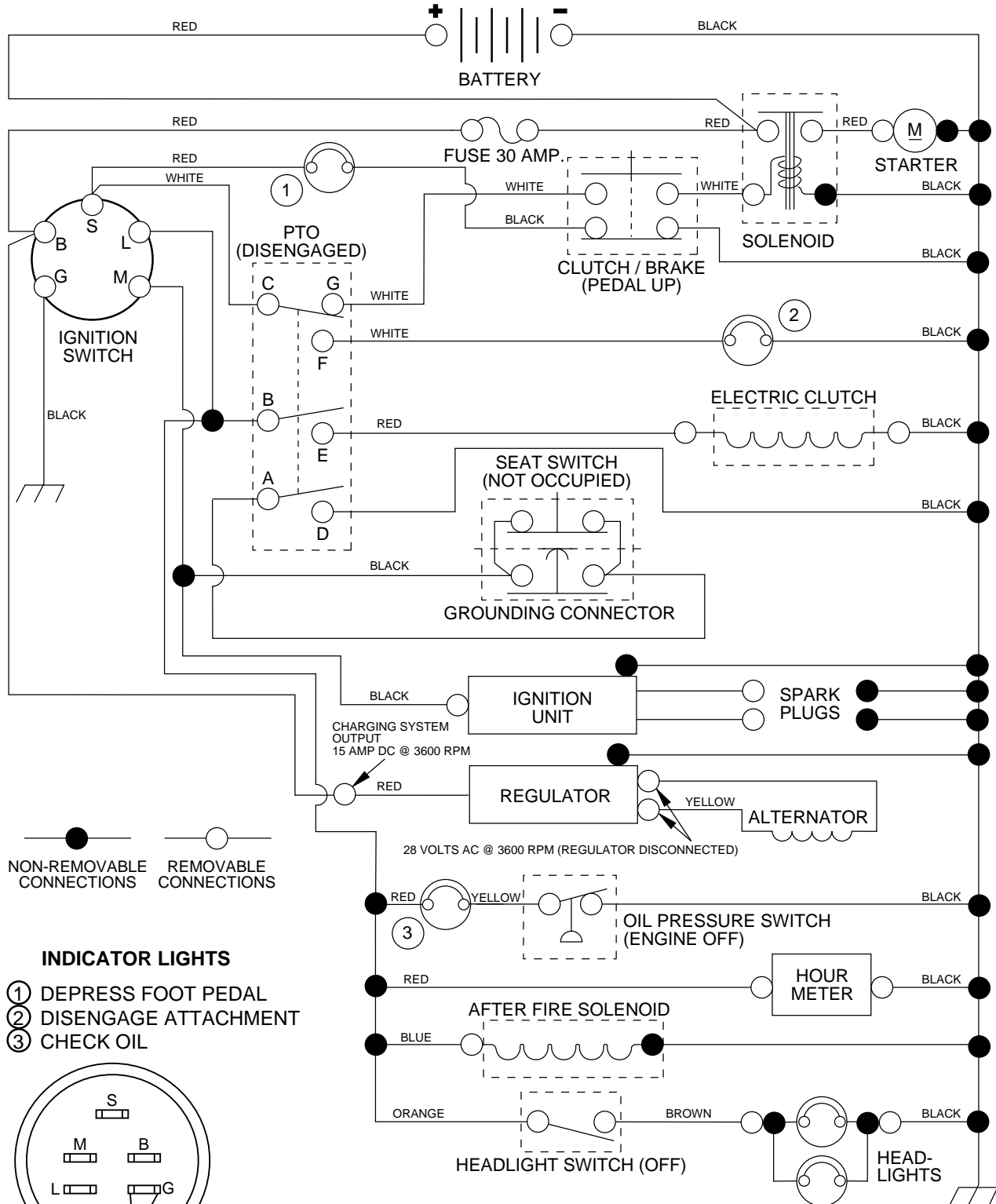

INDICATOR LIGHTS

- ① DEPRESS FOOT PEDAL
- ② DISENGAGE ATTACHMENT
- ③ CHECK OIL

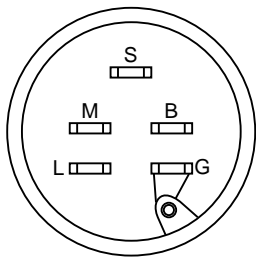

IGNITION SWITCH

| POSITION | CIRCUIT |
|----------|-----------|
| OFF | M + G |
| ON | B + L |
| START | B + S + L |

WIRING INSULATED CLIPS

NOTE: IF WIRING INSULATED CLIPS WERE REMOVED FOR SERVICING OF UNIT, THEY SHOULD BE REPLACED TO PROPERLY SECURE YOUR WIRING.

PTO SWITCH

| POSITION | CIRCUIT |
|----------|---------------------|
| OFF | C + G |
| ON | C + F, B + E, A + D |

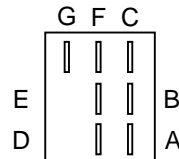

REPAIR PARTS

TRACTOR - - MODEL NO. GTH200 (954002022A)

DECALS

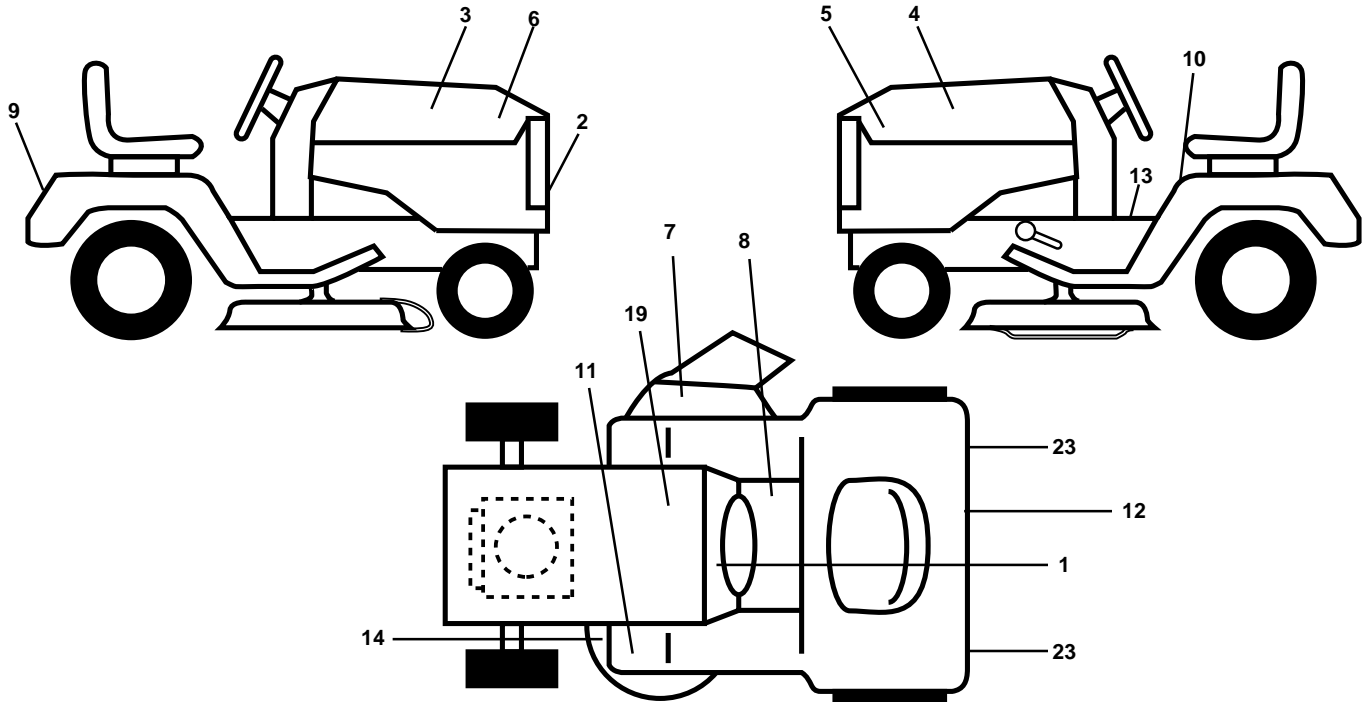

| KEY NO. | PART NO. | DESCRIPTION | KEY NO. | PART NO. | DESCRIPTION |
|---------|-----------|-----------------------------------|--|-----------|---|
| 1 | 532138956 | Decal, Operating Instruction | 23 | 532106202 | Reflector, Taillight |
| 2 | 532125989 | Decal, Grille Husqvarna "H" Logo | -- | 532138311 | Decal, Handle Lft Height Adjust (Lift Handle) |
| 3 | 532140728 | Decal, Hood, RH | -- | 532145246 | Pad Frest Rbr Sq Generic 95 |
| 4 | 532140729 | Decal, Hood, LH | -- | 532145247 | Fastener Pop-In Footrest (8 per) |
| 5 | 532140869 | Decal, Inst Hood LH GTH200 Hydro | -- | 532150183 | Manual, Owner's (English) |
| 6 | 532140868 | Decal, Insrt Hood RH GTH200 Hydro | -- | 532150184 | Manual, Owner's (French) |
| 7 | 532137259 | Decal, Warning Multi-Language | Accessories not included with tractor: | | |
| 8 | 532140837 | Decal, Brake Parking Saddle | -- | SH10 | Sleeve Hitch |
| 9 | 532131582 | Decal, Fender | -- | TA128 | Tire Chains |
| 10 | 532133795 | Decal, Caution | -- | GBD48 | Snow Blade |
| 11 | 532101892 | Decal, Clutch/Brake | -- | TA321 | #55 Wheel Weights |
| 12 | 532142342 | Decal, D-Bar Ctrl. Mvt Hyd YT/GT | -- | EA20 | Electric Assist Kit |
| 13 | 532142337 | Decal, Sdl Cold Start Hyd E/F | -- | GSB42 | Snow Blower |
| 14 | 532139346 | Decal, V-Belt Schematic | | | |
| 19 | 532145005 | Decal, Battery | | | |

WHEELS & TIRES

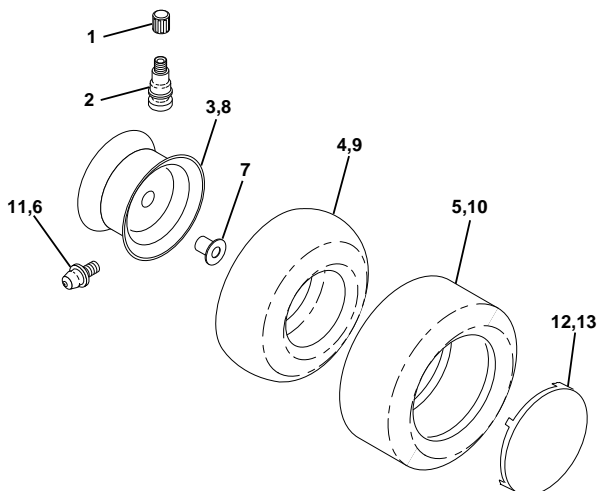

| KEY NO. | PART NO. | DESCRIPTION |
|---------|-----------|------------------------------------|
| 1 | 532059192 | Cap, Valve, Tire |
| 2 | 532065139 | Stem, Valve |
| 3 | 532141624 | Rim Assembly, Front |
| 4 | 532008134 | Tube, Front (Service Item Only) |
| 5 | 532106230 | Tire, Front |
| 6 | 532124957 | Fitting, Grease |
| 7 | 532124959 | Bearing, Flange (Front Wheel Only) |
| 8 | 532141625 | Rim Assembly, Rear |
| 9 | 532007154 | Tube, Rear (Service Item Only) |
| 10 | 532105588 | Tire, Rear |
| 11 | 532124860 | Fitting, Grease |
| 12 | 532124578 | Cover Wheel 8" White |
| 13 | 532124579 | Cover, Wheel 12" White |
| -- | 532144334 | Sealant, Tire (10 oz. Tube) |

NOTE: All component dimensions given in U.S. inches
1 inch = 25.4 mm

REPAIR PARTS

TRACTOR - - MODEL NO. GTH200 (954002022A)

ELECTRICAL

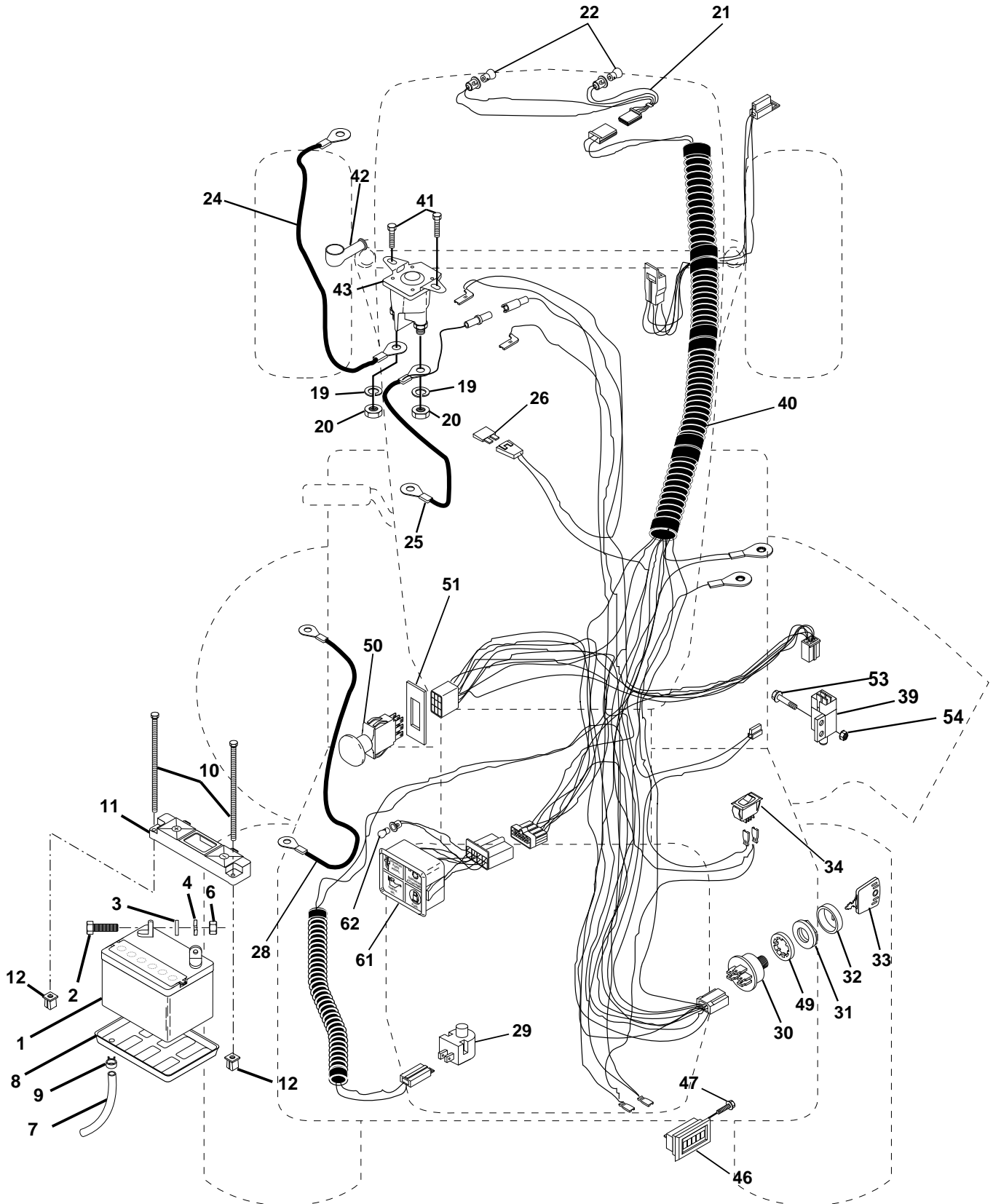

REPAIR PARTS

TRACTOR - - MODEL NO. GTH200 (954002022A)

ELECTRICAL

| KEY NO. | PART NO. | DESCRIPTION |
|---------|-----------|-----------------------------------|
| 1 | 532144927 | Battery |
| 2 | 874760412 | Bolt Hex Head 1/4-20 x 3/4 |
| 3 | 810040400 | Washer, Lock 1/4 |
| 4 | 819091016 | Washer 9/32 x 5/8 x 16 Ga |
| 6 | 873220400 | Nut Fin Hex 1/4-20 |
| 7 | 532007697 | Tube Plastic |
| 8 | 532124886 | Tray, Battery |
| 9 | 532109596 | Clamp, Hose |
| 10 | 532145211 | Bolt, Btr Frt 1/4-20 x 7-1/2 Zinc |
| 11 | 532145209 | Holddown Battery Dash Mount |
| 12 | 532145769 | Nut Push Nylon 1/4" Battery Frt. |
| 19 | 810090400 | Washer, Lock 1/4 |
| 20 | 873350400 | Nut, Jam Hex 1/4-20 |
| 21 | 532136850 | Harness Socket Light w/4152J |
| 22 | 532004152 | Bulb Light |
| 24 | 532004014 | Cable, Starter |
| 25 | 532146686 | Cable, Battery |
| 26 | 532108824 | Fuse |
| 28 | 532006408 | Cable, Ground |
| 29 | 532121305 | Switch, Plunger |
| 30 | 532144921 | Switch, Ign |
| 31 | 532140400 | Nut, Ignition Switch |
| 32 | 532141226 | Cover Switch Key |
| 33 | 532140401 | Key |
| 34 | 532110712 | Switch, Light |
| 39 | 532109553 | Intlk Switch |
| 40 | 532147341 | Harness Ign. |
| 41 | 817720408 | Screw 1/4-20 x 1/2 |
| 42 | 532131563 | Cover, Terminal Red |
| 43 | 532145673 | Solenoid |
| 46 | 532110940 | Meter Hour |
| 47 | 817011008 | Screw #10-24 x 1/2 |
| 49 | 811151000 | Washer, Lock Internal Tooth 5/8 |
| 50 | 532140404 | Switch, PTO |
| 51 | 532140405 | Ring Retainer PTO |
| 53 | 871031008 | Screw Hex Washer Hd #10-32 x 1 |
| 54 | 873951000 | Nut Keps #10-32 |
| 61 | 532138101 | Light Pkg Asm |
| 62 | 532110143 | Bulb, Light Pkg. |

NOTE: All component dimensions given in U.S. inches
1 inch = 25.4 mm

REPAIR PARTS

TRACTOR - - MODEL NO. GTH200 (954002022A)

CHASSIS AND ENCLOSURES

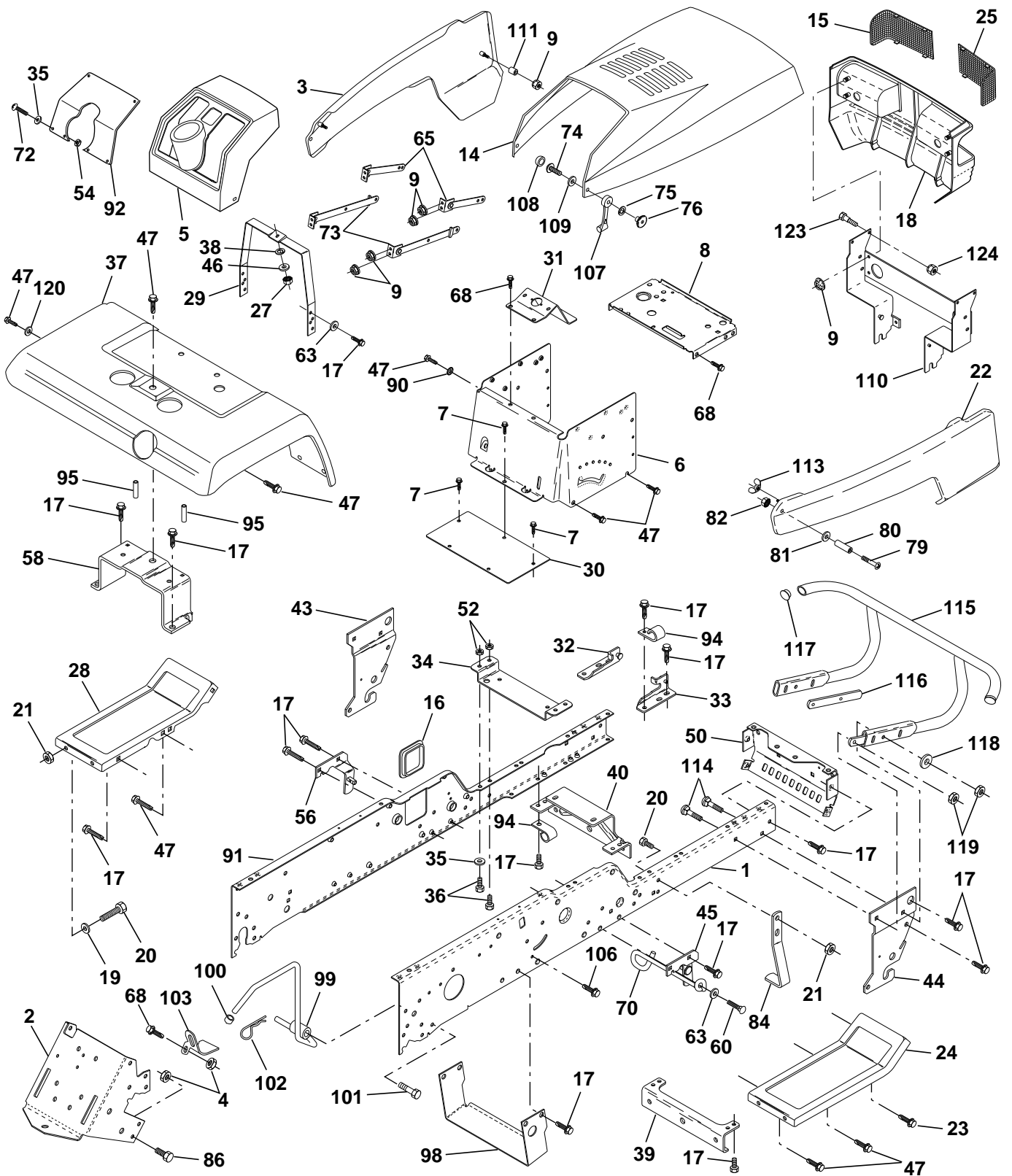

REPAIR PARTS

TRACTOR - - MODEL NO. GTH200 (954002022A)

CHASSIS AND ENCLOSURES

| KEY NO. | PART NO. | DESCRIPTION | KEY NO. | PART NO. | DESCRIPTION |
|---------|-----------|--------------------------------|---------|-----------|------------------------------------|
| 1 | 532144737 | Rail, Frame RH | 63 | 819131614 | Washer 13/32 x 1 x 14 Ga. |
| 2 | 532140506 | Drawbar, Gt | 65 | 532149577 | Strap, Asm. Hinge Front |
| 3 | 532143364 | Panel Asm., Side LH | 68 | 817490508 | Screw, Thdrol 5/16-18 x 1/2 |
| 4 | 873800700 | Nut, Lock Hex 7/16 Unc | 70 | 532137159 | Guide, Belt Mid Span |
| 5 | 532140452 | Dash, Plastic Black | 72 | 874180512 | Screw, Mach Trhd 5/16-18 x 3/4 |
| 6 | 532145053 | Dash 1-PCS, Lower | 73 | 532149580 | Strap, Asm. Hinge Rear |
| 7 | 817720408 | Screw, Thd Cut 1/4-20 x 1/2 | 74 | 874191008 | Screw, Machine #10-24 |
| 8 | 532145166 | Support, Battery | 75 | 810071000 | Washer, Lock #10 |
| 9 | 532108067 | Nut Pal | 76 | 532125004 | Nut, Weld #10-24 |
| 14 | 532125454 | Hood Asm., Pnt | 79 | 874981020 | Screw, Machine #10-24 x 1/4 |
| 15 | 532124251 | Lens, Headlight RH | 80 | 532007206 | Spacer, Split |
| 16 | 532121794 | Cover, Access | 81 | 819070818 | Washer 7/32 x 1/2 x 18 Ga. |
| 17 | 817490612 | Screw, Thdrol 3/8-16 x 3/4 | 82 | 873731000 | Nut #10-24 |
| 18 | 532127320 | Grille | 84 | 532142992 | Stop, Over Center 44" 20/23" T. 94 |
| 19 | 819131312 | Washer 13/32 x 13/16 x 12 Ga. | 86 | 874760716 | Bolt, Fin Hex 7/16-14 Unc x 1 |
| 20 | 874760616 | Bolt, Fin Hex 3/8-16 x 1 | 90 | 811050600 | Washer, Lock External Tooth 3/8 |
| 21 | 873800600 | Nut, Lock Hex W/Wsh 3/8-16 Unc | 91 | 532144735 | Rail, Frame Lh |
| 22 | 532143365 | Panel Asm., Side RH | 92 | 532141626 | Plate, Silkscreen Dash |
| 24 | 532147202 | Footrest, RH | 94 | 532100207 | Clip, Fuel Line |
| 25 | 532124250 | Lens Headlight LH | 95 | 532105531 | Push Nut, Nylon |
| 27 | 873220400 | Nut Fin Hex 1/4-20 | 98 | 532140503 | Bracket Chassis Skid |
| 28 | 532147203 | Footrest, LH | 99 | 532140871 | Rod Asm. Bypass |
| 29 | 532145205 | Bracket, Support Dash | 100 | 532124236 | Cap Brake Parking Red |
| 30 | 532145052 | Saddle | 101 | 817490628 | Screw Thdrol. 3/8-16 x 1-3/4 |
| 31 | 532145183 | Brace, Support Steering | 102 | 532124788 | Retainer Spring 1" |
| 32 | 532141315 | Bracket Asm., Frame Pivot Lh | 103 | 532142273 | Bracket Lock Bypass |
| 33 | 532141314 | Bracket Asm., Frame Pivot Rh | 106 | 532138776 | Screw Thdrol. Hex Hd Zinc Mur |
| 34 | 532142131 | Bracket, Engine Support Rear | 107 | 532109808 | Latch, Chute Blk |
| 35 | 819111116 | Washer 11/32 x 11/16 x 16 Ga. | 108 | 532110356 | Cap, Snap Black |
| 36 | 874780512 | Bolt, Fin Hex 5/16-18 x 3/4 | 109 | 532110357 | Cap, Washer Snap |
| 37 | 532141449 | Fender, Pnt. | 110 | 532140625 | Support Asm. Grille |
| 38 | 810040400 | Washer, Lock 1/4 | 111 | 532127316 | Retainer |
| 39 | 532136961 | Bracket, Axle Front | 113 | 532123198 | Nut, Plastic Locking Wing 1/4-20 |
| 40 | 532142132 | Bracket, Support Axle/Engine | 114 | 872140610 | Bolt, Carriage 3/8-16 x 1-1/4 |
| 43 | 532136939 | Bracket, Spnsn Front Lh | 115 | 532141460 | Bumper Asm. |
| 44 | 532136940 | Bracket, Spnsn Front Rh | 116 | 532141461 | Bracket Extension Bumper |
| 45 | 532138460 | Bracket Asm., Susp Chassis Rh | 117 | 532143679 | Plug Plastic |
| 46 | 819091216 | Washer 9/32 x 3/4 x 16 Ga. | 118 | 819131316 | Washer 13/32 x 13/16 x 16 Ga. |
| 47 | 817490608 | Screw Thdrol 3/8-16 x 1/2 | 119 | 873680600 | Nut Crownlock 3/8-16 UNC |
| 50 | 532136575 | Bracket, Chassis Front | 120 | 819131616 | Washer 13/32 x 1 x 16 Ga. |
| 52 | 873800500 | Locknut, Hex W/Ins 5/16-18 Unc | 123 | 532123481 | Bolt Shoulder 1/4-20 |
| 54 | 873510500 | Nut 5/16-18 | 124 | 873800400 | Nut Crownlock 1/4-20 |
| 56 | 532138461 | Bracket Asm., Susp Chassis Lh | -- | 532125085 | Plug, Hole |
| 58 | 532137113 | Bracket Asm., Fender | | | |
| 60 | 817490620 | Screw Thdrol 3/8-16 x 1-1/4 | | | |

NOTE: All component dimensions given in U.S. inches
1 inch = 25.4 mm

REPAIR PARTS

TRACTOR - - MODEL NO. GTH200 (954002022A)

GROUND DRIVE

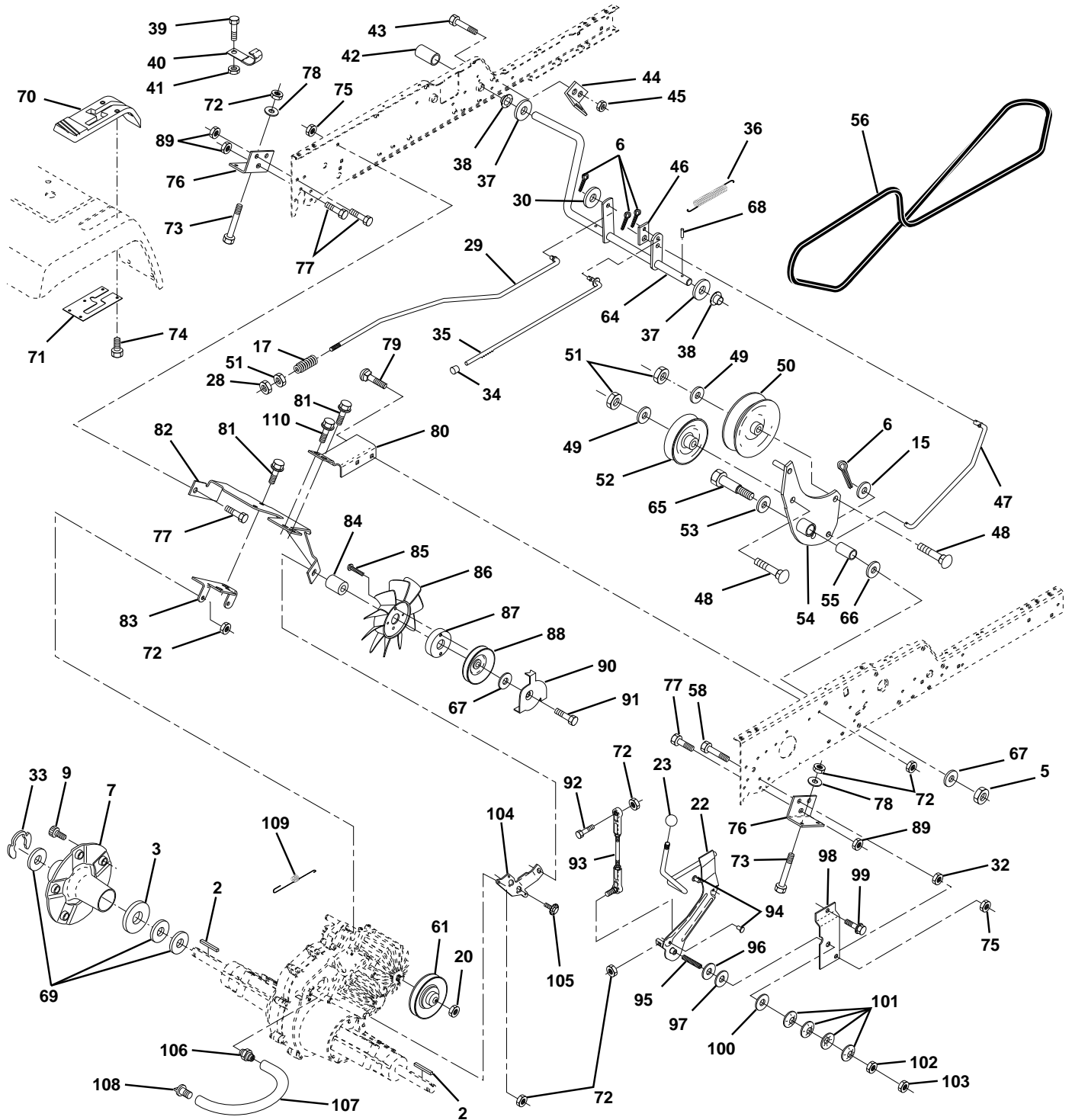

REPAIR PARTS

TRACTOR - - MODEL NO. GTH200 (954002022A)

GROUND DRIVE

| KEY NO. | PART NO. | DESCRIPTION | KEY NO. | PART NO. | DESCRIPTION |
|---------|-----------|------------------------------------|---------|-----------|------------------------------|
| 2 | 532007070 | Key 1/4 x 2.5 | 69 | 532123800 | Washer |
| 3 | 532007563 | Washer Thrust Axle Harden | 70 | 532139989 | Console Hydro Fender |
| 5 | 873680600 | Nut Crownlock 3/8-16 | 71 | 532140927 | Plate Console Shift |
| 6 | 876020412 | Pin Cotter 1/8 x 3/4 | 72 | 873800500 | Locknut Hex W/Washer Insert |
| 7 | 532140507 | Wheel Hub Asm. | 73 | 874780548 | Bolt Fin Hex 5/16-18 x 3 |
| 9 | 532140080 | Bolt Hub | 74 | 532142432 | Screw, Hex Wsh Hi-Lo 1/4-1/2 |
| 15 | 819131316 | Washer 13/32 x 13/16 x 16 Ga. | 75 | 873800700 | Nut Lock Hex 7/16 |
| 17 | 532140921 | Spring Rod Brake | 76 | 532140481 | Bracket Transaxle |
| 20 | 873940800 | Nut Hex Jam Toplock 1/2-20 | 77 | 874760716 | Bolt Fin Hex 7/16-14 x 1 |
| 22 | 532140498 | Shaft Arm Asm | 78 | 819111212 | Washer 11/32 x 3/4 x 12 Ga. |
| 23 | 532140845 | Knob | 79 | 872110505 | Bolt Carriage 5/16-18 x 5/8 |
| 28 | 873350600 | Nut, Hex Jam 3/8-16 | 80 | 532140484 | Bracket Torque RH |
| 29 | 532140494 | Brake Rod | 81 | 817490612 | Screw Thdrol 3/8-16 x 3/4 |
| 30 | 819131616 | Washer 13/32 x 1 x 16Ga | 82 | 532140482 | Bracket Mount Torque/Fan |
| 32 | 873220700 | Nut Hex 7/16-14 | 83 | 532140479 | Strap Torque Mid |
| 33 | 812000053 | Ring E | 84 | 532140490 | Spacer |
| 34 | 532071673 | Cap Plunger | 85 | 817541020 | Screw #10-24 x 1-1/4 |
| 35 | 532137648 | Rod Parking Brake | 86 | 532140462 | Fan 7" Hydro |
| 36 | 532149412 | Spring Extension | 87 | 532140491 | Adapter Fan |
| 37 | 532121749 | Washer 25/32 x 1-1/4 x 16 Ga. | 88 | 532140492 | Pulley Idler |
| 38 | 532110895 | Nyliner | 89 | 873680700 | Nut, Crownlock 7/16-14 |
| 39 | 874321016 | Screw Fin #10-24 x 1 | 90 | 532140489 | Keeper Belt |
| 40 | 532005304 | Actuator Interlock Switch | 91 | 817490644 | Screw Thdrol 3/8-16 x 2-3/4 |
| 41 | 873631000 | Nut Lock #10-24 | 92 | 874760520 | Bolt Fin Hex 5/16-18 x 1.75 |
| 42 | 532123533 | Cover Pedal | 93 | 532140502 | Link Shift Asm |
| 43 | 874760412 | Bolt Hex Head 1/4-20 x 3/4 | 94 | 532133835 | Fastner Christmas Tree |
| 44 | 532104601 | Bracket Interlock | 95 | 823200528 | Screw Set 5/16-18 x 1.75 |
| 45 | 873800400 | Nut Lock W/Insert 1/4-20 | 96 | 532141103 | Washer Nickel Plated |
| 46 | 532145170 | Retainer Spring | 97 | 532126874 | Bearing Trust |
| 47 | 532138228 | Clutch Rod | 98 | 532141004 | Bracket Shift |
| 48 | 872110614 | Bolt Carriage 3/8-16 x 1-3/4 Gr. 5 | 99 | 817490624 | Screw Thdrol 3/8-16 x 1-1/2 |
| 49 | 819131413 | Washer 13/32 x 7/8 x 13 Ga | 100 | 532126881 | Washer Compression |
| 50 | 532131494 | Pulley Idler Flat | 101 | 532059285 | Washer Bellville |
| 51 | 873800600 | Nut Lock Hex 3/8-16 | 102 | 873560500 | Nut Hex Nylok |
| 52 | 532139123 | Pulley Idler Grooved | 103 | 873350500 | Nut Hex Jam 5/16-18 |
| 53 | 532000207 | Washer Hardened | 104 | 532140480 | Bracket Idler |
| 54 | 532138390 | Clutch Arm Asm | 105 | 817580408 | Screw Tap 1/4-20 x 1/2 |
| 55 | 532105706 | Bearing, Idler | 106 | 532142576 | Fitting Vent Hose |
| 56 | 532140218 | V-Belt | 107 | 532142577 | Vent Hose |
| 58 | 874760724 | Bolt Fin Hex 7/16-14 x 1-1/2 | 108 | 532142578 | Cap Vent |
| 61 | 532140488 | Pullery Transaxle | 109 | 532140929 | Spring Return Brake |
| 64 | 532137649 | Shaft Asm Brake Parking Clutch | 110 | 532088652 | Screw, Hinge |
| 65 | 532067609 | Bolt Shoulder | -- | 532140343 | Transaxle Hydro |
| 66 | 532140296 | Washer Hardened | | | |
| 67 | 819131312 | Washer 13/32 x 13/16 x 12 Ga | | | |
| 68 | 532005142 | Pin Roll | | | |

NOTE: All component dimensions given in U.S. inches
1 inch = 25.4 mm

REPAIR PARTS

TRACTOR -- MODEL NO. GTH200 (954002022A)

STEERING ASSEMBLY

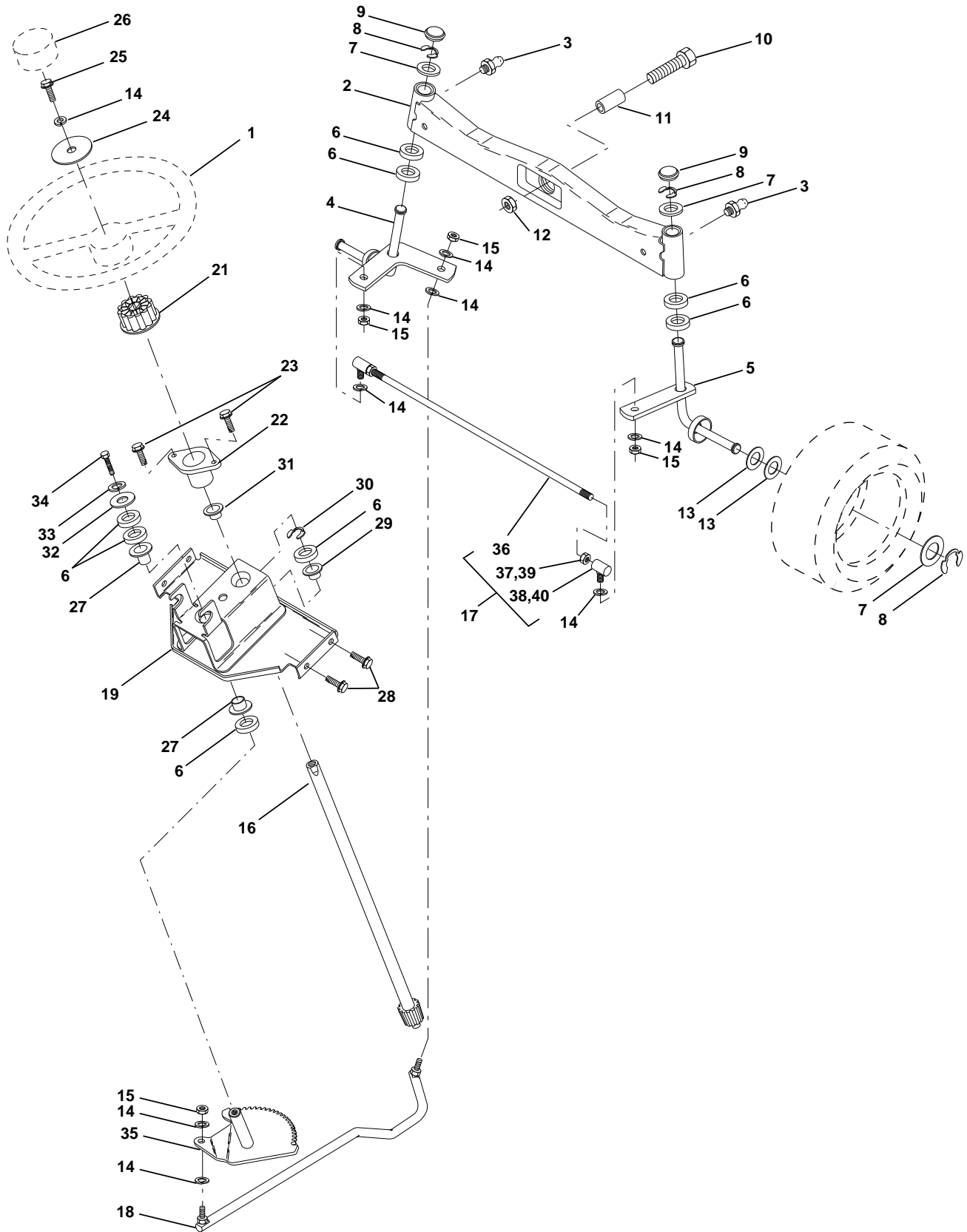

REPAIR PARTS

TRACTOR - - MODEL NO. GTH200 (954002022A)

STEERING ASSEMBLY

| KEY NO. | PART NO. | DESCRIPTION |
|---------|-----------|--|
| 1 | 532124415 | Wheel, Steering |
| 2 | 532137094 | Axle Asm., Front |
| 3 | 532124836 | Fitting, Grease |
| 4 | 532136960 | Spindle Asm, LH |
| 5 | 532136959 | Spindle Asm., RH |
| 6 | 532124956 | Bearing, Race Thrust Harden |
| 7 | 532121748 | Washer 25/32 x 1-5/8 x 16 Ga. |
| 8 | 812000029 | Ring, Klip #T5304-75 |
| 9 | 532121232 | Cap, Spindle |
| 10 | 874781044 | Bolt, Fin Hex 5/8-11 x 2-3/4 |
| 11 | 532136518 | Spacer, Brg. Axle Front |
| 12 | 873901000 | Nut, Lock Flange 5/8-11 Unc |
| 13 | 532121749 | Washer 25/32 x 1-1/4 x 16 Ga. |
| 14 | 810040600 | Washer, Lock Hvy Hlcl Spr 3/8 |
| 15 | 873610600 | Nut, Fin Hex 3/8-24 Unf |
| 16 | 532145103 | Shaft Asm., Steering |
| 17 | 532137347 | Rod Asm., Tie Ball J Ball Vgt (Inc. Key No. 36-40) |
| 18 | 532137155 | Draglink, Ball Joint Solid Vgt |
| 19 | 532146611 | Support Asm., Steering Vgt |
| 21 | 532100711 | Adapter, Wheel Steering |
| 22 | 532124720 | Bushing, Strg. Blk |
| 23 | 817431008 | Screw, Slftp #10-16 x 1/2 Ty-b |
| 24 | 819133808 | Washer 13/32 x 2-3/8 x 8 Ga. |
| 25 | 874780616 | Bolt, Fin Hex 3/8-16 x 1 Gr. 5 |
| 26 | 532124416 | Cap , Wheel Steering |
| 27 | 532124937 | Bearing, Col. Strg. |
| 28 | 817490612 | Screw Thdrol 3/8-16 x 3/4 |
| 29 | 532104239 | Bearing, Flange |
| 30 | 812000034 | Ring, Klip Truarc #5304-75 |
| 31 | 532138136 | Bushing, Nyliner Snap |
| 32 | 819111610 | Washer 11/32 x 1 x 10 Ga. |
| 33 | 810040500 | Washer, Lock Hvy Hlcl Spr 5/16 |
| 34 | 874760512 | Bolt, Hex Hd 5/16-18 x 3/4 |
| 35 | 532138059 | Gear, Sector Steering |
| 36 | 532137156 | Tie Rod |
| 37 | 873360600 | Jam Nut RH Thread |
| 38 | 532109850 | Joint Asm. Ball RH Thread |
| 39 | 873700600 | Jam Nut LH Thread |
| 40 | 532109851 | Joint Asm. Ball LH Thread |

NOTE: All component dimensions given in U.S. inches
1 inch = 25.4 mm

REPAIR PARTS

TRACTOR - - MODEL NO. GTH200 (954002022A)

ENGINE

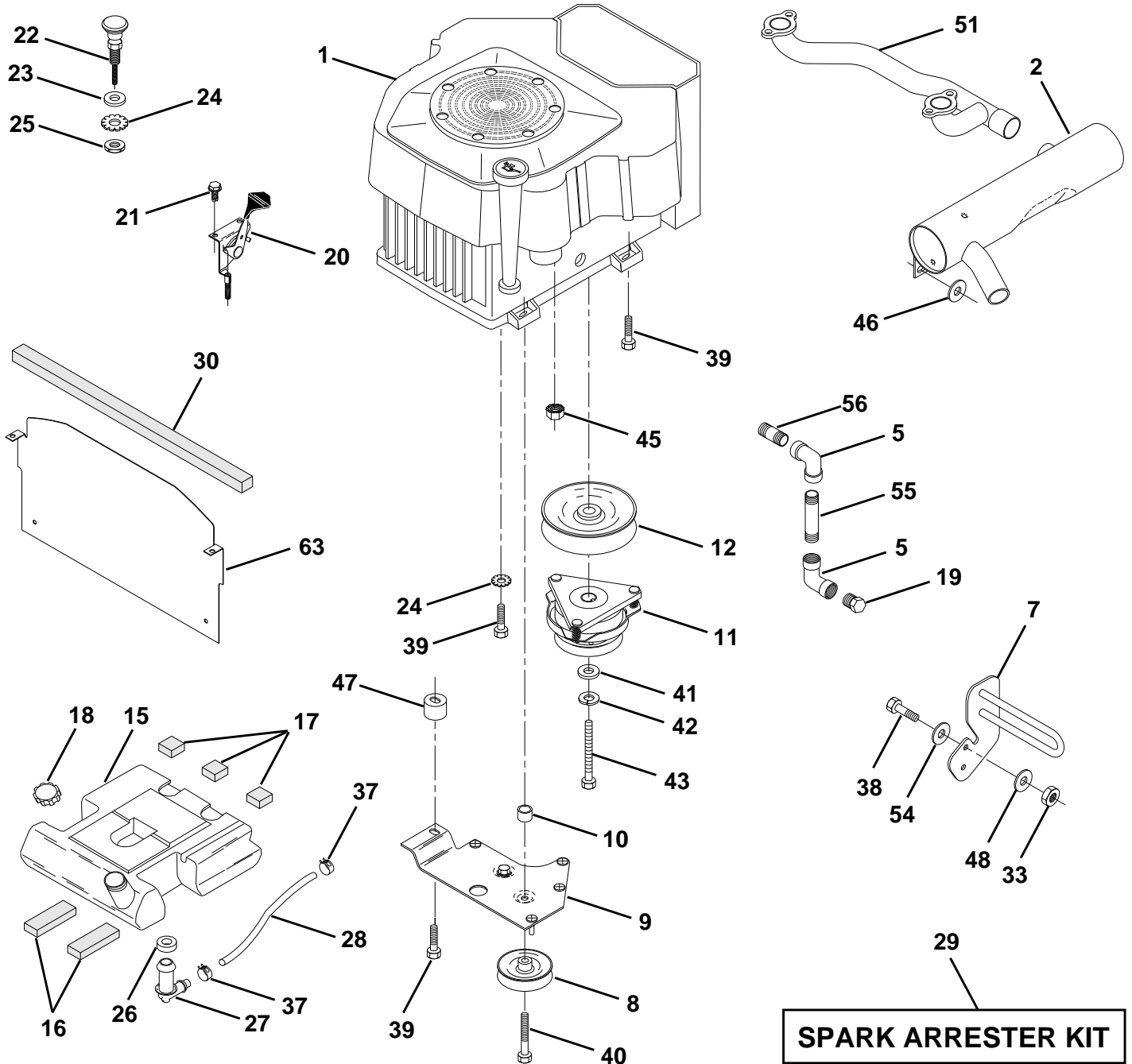

REPAIR PARTS

TRACTOR - - MODEL NO. GTH200 (954002022A)

ENGINE

| KEY NO. | PART NO. | DESCRIPTION |
|---------|-----------|--|
| 1 | ----- | Engine Kohler, Model No. CV20S |
| 2 | 532144636 | Muffler VGT Cylinder |
| 5 | 813200300 | Elbow STD 90 Degree 3/8-18 NPT |
| 7 | 532143599 | Muffler Assembly Guard |
| 8 | 532121361 | Pulley V-Idler |
| 9 | 532145109 | Stop Keeper Asm VGT |
| 10 | 532105432 | Bushing |
| 11 | 532140923 | Clutch Electric |
| 12 | 532143996 | Pulley Engine VGT Elect Clutch |
| 15 | 532141069 | Tank Fuel W/Sym Vented |
| 16 | 532109227 | Pad Spacer |
| 17 | 532106082 | Pad Spacer |
| 18 | 532140527 | Cap Asm Fuel W/Sym Vented |
| 19 | 813290300 | Plug Oil Drain (Order From Engine Manufacturer) |
| 20 | 532132747 | Control Throttle |
| 21 | 817720410 | Screw Hex Thd Cut 1/4-20 X 5/8 |
| 22 | 532132781 | Control Choke |
| 23 | 819131316 | Washer 13/32 X 13/16 x 16 Ga |
| 24 | 811050600 | Washer Ext Tooth 3/8 |
| 25 | 873610600 | Nut Fin Hex 3/8 - 24 UNF |
| 26 | 532124952 | Bushing |
| 27 | 532139277 | Stem Tank Fuel |
| 28 | 532124703 | Fuel Line |
| 29 | 532132920 | Spark Arrester Kit |
| 30 | 532105037 | Strip Foam 18" |
| 33 | 873800600 | Nut, Hex W/Ins. 3/8-16 UNC |
| 37 | 532123487 | Clamp Hose |
| 38 | 874780624 | Bolt, Fin Hex 3/8-16 UNC x 1-1/2 |
| 39 | 817490636 | Screw TT 3/8-16 x 2-1/4 UNC |
| 40 | 817490664 | Screw TT 3/8-16 x 4 UNC |
| 41 | 532126197 | Washer 1-1/2 OD X 15/32 ID X .250 |
| 42 | 810040700 | Washer Lock 7/16 |
| 43 | 871170768 | Bolt Hex 7/16-20 X 4-1/4 Ga 5 |
| 45 | 532128861 | Nut Flange 1/4-20 Starter Nut |
| 46 | 819131616 | Washer 13/32 x 1 x 16 Ga. |
| 47 | 532142040 | Spacer Engine |
| 48 | 819132007 | Washer 13/32 x 1-1/4 x 7 Ga. |
| 51 | 532140787 | Pipe Crossover |
| 54 | 819131414 | Washer Flat 13/32 x 7/8 x 14 Ga. |
| 55 | 813090336 | Nipple, Pipe 3/8 NPT x 4-1/2 |
| 56 | 813090308 | Nipple, Pipe 3/8 NPT x 1.00 |
| 63 | 532145549 | Shield, Heat VGT YP/Husq. |

NOTE: All component dimensions given in U.S. inches
1 inch = 25.4 mm

REPAIR PARTS

TRACTOR - - MODEL NO. GTH200 (954002022A)

MOWER DECK

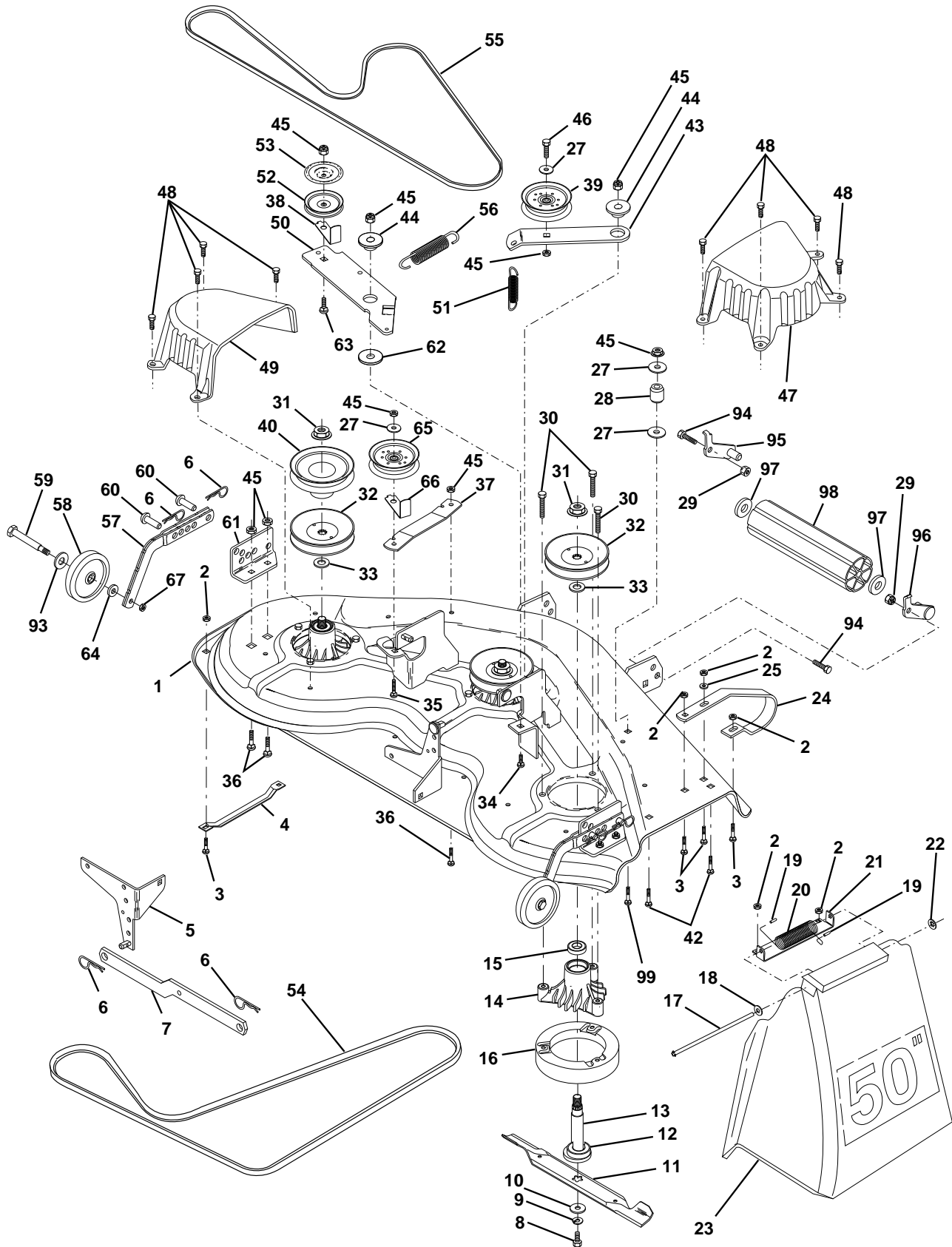

REPAIR PARTS

TRACTOR - - MODEL NO. GTH200 (954002022A)

MOWER DECK

| KEY NO. | PART NO. | DESCRIPTION | KEY NO. | PART NO. | DESCRIPTION |
|---------|-----------|---|---------|-----------|---|
| 1 | 532136457 | Deck Asm., Mower 50" Vented | 43 | 532136460 | Arm, Idler Secondary |
| 2 | 873680500 | Nut, Crownlock 5/16-18 Unc | 44 | 532122052 | Spacer, Retainer |
| 3 | 872110506 | Bolt, Carriage 5/16-18 x 3/4 | 45 | 873680600 | Nut, Crownlock 3/8-16 Unc |
| 4 | 532125074 | Runner, Mower LH | 46 | 874760628 | Bolt, Fin Hex 3/8-16 Unc x 1-3/4 |
| 5 | 532138457 | Bracket Asm., Sway Bar | 47 | 532137200 | Cover, Mandrel RH |
| 6 | 532124670 | Retainer, Spring | 48 | 532137729 | Screw, Thd Roll 1/4-20 x 5/8 |
| 7 | 532130832 | Arm Suspension, Rear | 49 | 532136574 | Cover, Mandrel LH |
| 8 | 532850857 | Bolt 3/8-24 x 1.25 Gr. 8 Patched | 50 | 532137272 | Arm, Idler Primary |
| 9 | 810030600 | Washer, Lock Hvy 3/8 Unplated | 51 | 532137273 | Spring, Secondary |
| 10 | 532140296 | Washer, Hard Blade Mower Vented | 52 | 532139245 | Pulley, Idler V Groove |
| 11 | 532137380 | Blade (3 Required) | 53 | 532137789 | Shield, Idler |
| 12 | 532129895 | Bearing, Ball #6204 (Mandrel) | 54 | 532139573 | V-Belt, Mower Primary |
| 13 | 532137553 | Shaft Asm., W/Lower Brg (Includes Key No. 12) | 55 | 532144959 | V-Belt, Mower Secondary |
| 14 | 532137152 | Housing, Mandrel 50" Vent | 56 | 532138687 | Spring, Primary |
| 15 | 532110485 | Bearing, Ball Mandrel | 57 | 532136577 | Bar Asm., Wheel Gauge |
| 16 | 532140329 | Stripper, Mower Vented | 58 | 532105455 | Wheel, Gauge |
| 17 | 532106735 | Rod, Hinge | 59 | 532124842 | Bolt, Shoulder |
| 18 | 819111016 | Washer 11/32 x 5/8 x 16 Ga. | 60 | 532139031 | Pin, Clevis |
| 19 | 532105304 | Cap, Sleeve | 61 | 532136573 | Bracket, Wheel Gauge |
| 20 | 532123713 | Spring, Torsion Deflector | 62 | 532133943 | Washer Hardened |
| 21 | 532137607 | Bracket, Deflector | 63 | 872110612 | Bolt Carriage 3/8-16 x 1-1/2 |
| 22 | 532110452 | Nut, Push | 64 | 819121414 | Washer 3/8 x 7/8 x 14 Ga. |
| 23 | 532110509 | Shield, Deflector Mower | 65 | 532102403 | Pulley Idler Flat Mower |
| 24 | 532136320 | Runner, RH | 66 | 532139622 | Keeper, Belt Idler 50" Vent |
| 25 | 819111216 | Washer 11/32 x 3/4 x 16 Ga. | 67 | 873930600 | Nut, Center Lock 3/8-16 |
| 27 | 819131316 | Washer 13/32 x 13/16 x 16 Ga. | 93 | 819171512 | Washer 17/32 x 15/16 x 12 Ga. |
| 28 | 532132823 | Spacer, Spring Stop Idler | 94 | 874760616 | Bolt, Fin Hex 3/8-16 UNC x 1 |
| 29 | 873800600 | Nut, Lock Hex W/Wsh 3/8-16 Unc | 95 | 532132274 | Bracket, Asm. Noseroller LH |
| 30 | 532138776 | Screw Thdrol Hex Head | 96 | 532132273 | Bracket, Asm. Noseroller RH |
| 31 | 532137266 | Nut, Flg Top Lock Cntr 9/16 | 97 | 819171416 | Washer 17/32 x 7/8 x 16 Ga. |
| 32 | 532129861 | Pulley, Mandrel | 98 | 532132264 | Roller, Nose |
| 33 | 532129963 | Washer, Spacer Mower Vented | 99 | 872110614 | Bolt, Carriage 3/8-16 x 1-3/4 Gr. 5 |
| 34 | 872140610 | Bolt, Carriage 3/8-16 x 1-1/4 | -- | 532143651 | Mandrel Asm (Includes Key Nos. 8-10, 12-15, 31 and 33) |
| 35 | 872110616 | Bolt, Carriage 3/8-16 x 2 | -- | 532141051 | Mower Asm Service (Std. Deck - Order separately all Nose Roller and all Gauge Wheel components) |
| 36 | 872110608 | Bolt, Carriage 3/8-16 x 1 Gr. 5 | | | |
| 37 | 532137166 | Stiffener, Arm Idler | | | |
| 38 | 532137554 | Keeper, Belt Idler | | | |
| 39 | 532131494 | Pulley, Idler Flat | | | |
| 40 | 532136572 | Pulley, Driven | | | |
| 42 | 872140506 | Bolt, Carriage 5/16-18 Unc x 3/4 | | | |

NOTE: All component dimensions given in U.S. inches
1 inch = 25.4 mm

REPAIR PARTS

TRACTOR - - MODEL NO. GTH200 (954002022A)

LIFT ASSEMBLY

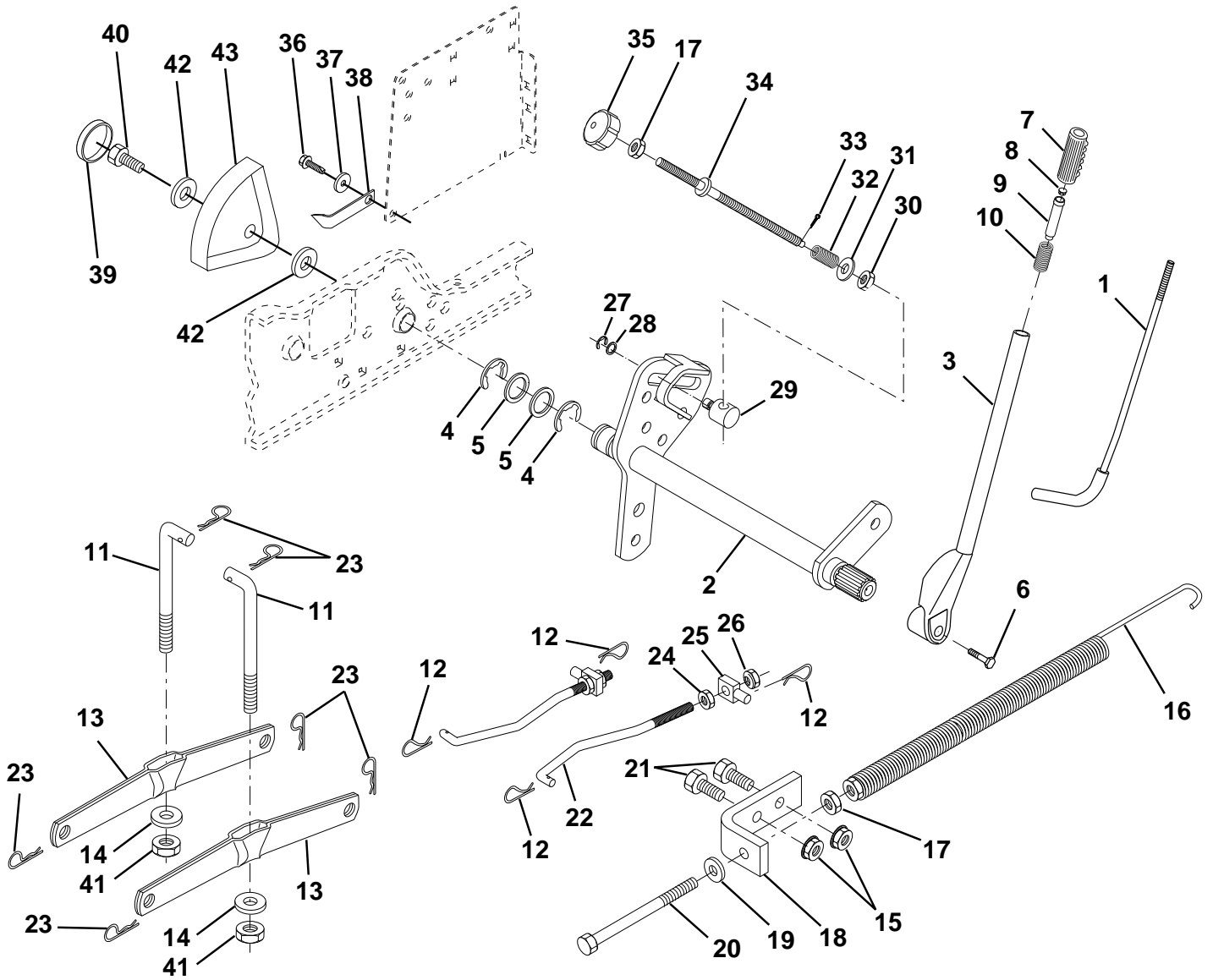

REPAIR PARTS

TRACTOR - - MODEL NO. GTH200 (954002022A)

LIFT ASSEMBLY

| KEY NO. | PART NO. | DESCRIPTION |
|---------|-----------|--------------------------------|
| 1 | 532121006 | Rod Asm., Lever |
| 2 | 532145542 | Shaft Asm., Lift Vgt |
| 3 | 532121002 | Lever Asm., Lift Rh |
| 4 | 812000022 | E-Ring Truarc #5133-87 |
| 5 | 819292016 | Washer 29/32 x 1-1/4 x 16 Ga. |
| 6 | 874780624 | Bolt, Fin Hex 3/8-16 x 1-1/2 |
| 7 | 532125631 | Grip, Handle Fluted |
| 8 | 532124526 | Button, Plunger |
| 9 | 532122364 | Plunger, Lever Lift |
| 10 | 532124874 | Spring 2-1/8" |
| 11 | 532146704 | Link Lift |
| 12 | 532124660 | Retainer, Spring |
| 13 | 532139868 | Arm, Suspension Vgt |
| 14 | 532140302 | Bearing |
| 15 | 873800600 | Nut, Lock Hex W/Wsh 3/8-16 Unc |
| 16 | 532124687 | Spring Asm., Assist Lift |
| 17 | 873350600 | Nut, Hex Jam 3/8-16 Unc |
| 18 | 532143363 | Bracket, Spring Assist |
| 19 | 819131316 | Washer 13/32 x 13/16 x 16 Ga. |
| 20 | 532005328 | Bolt, Adjust Spring Assist |
| 21 | 874760616 | Bolt, Fin Hex 3/8-16 x 1 |
| 22 | 532127218 | Link, Front |
| 23 | 532124670 | Retainer, Spring |
| 24 | 873350800 | Nut, Jam Hex 1/2-13 Unc |
| 25 | 532130171 | Trunnion |
| 26 | 873800800 | Nut, Lock W/Wsh 1/2-13 Unc |
| 27 | 812000037 | Ring, Klip #T5304-37 |
| 28 | 819151216 | Washer 15/32 x 3/4 x 16 Ga. |
| 29 | 532110810 | Trunnion, Dp Stop Dbl Thds Plt |
| 30 | 532110807 | Nut, Special |
| 31 | 819131016 | Washer 13/32 x 5/8 x 16 Ga. |
| 32 | 532137150 | Spring, Compression Inf Hgt |
| 33 | 876020308 | Pin, Cotter 3/32 x 1/2 |
| 34 | 532137167 | Rod, Adj Lift |
| 35 | 532138057 | Knob, Inf 3/8-16 Unc |
| 36 | 817490612 | Screw, Thdrol 3/8-16 x 3/4 |
| 37 | 532120529 | Washer, Nylon |
| 38 | 532138346 | Pointer, Pnt Height Indicator |
| 39 | 532123935 | Plug, Hole |
| 40 | 817490512 | Screw Thdrol 5/16-18 x 3/4 |
| 41 | 873540600 | Nut, Crownlock 3/8-24 |
| 42 | 819112410 | Washer 11/32 x 1-1/2 x 10 Ga. |
| 43 | 532123934 | Scale, Indicator Height |

NOTE: All component dimensions given in U.S. inches
1 inch = 25.4 mm

REPAIR PARTS

TRACTOR - - MODEL NO. GTH200 (954002022A)

SEAT ASSEMBLY

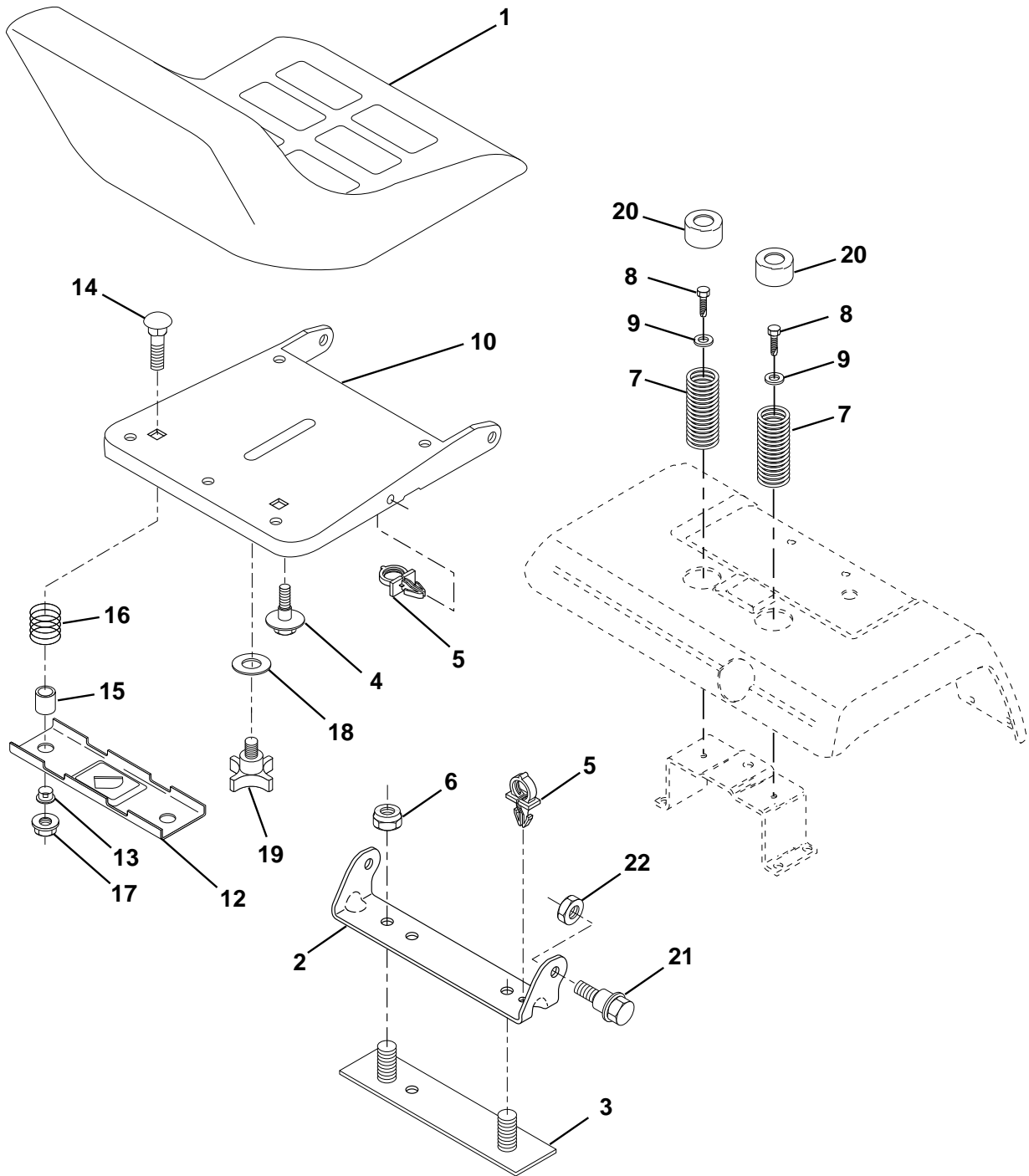

REPAIR PARTS

TRACTOR - - MODEL NO. GTH200 (954002022A)

SEAT ASSEMBLY

| KEY NO. | PART NO. | DESCRIPTION |
|---------|-----------|---------------------------------|
| 1 | 532141525 | Seat |
| 2 | 532140551 | Bracket, Pivot Seat |
| 3 | 532140675 | Strap, Fender |
| 4 | 532127018 | Bolt, Shoulder 5/16-18 X .62 |
| 5 | 532145006 | Clip, Push In Hinged |
| 6 | 873800600 | Nut, Lock Hex W/Ins. 3/8-16 Unc |
| 7 | 532124181 | Spring, Seat Cprsn |
| 8 | 817490508 | Screw, Thdrol 5/16-18 X 1/2 |
| 9 | 819131614 | Washer 13/32 X 1 X 14 Ga. |
| 10 | 532140552 | Pan, Seat |
| 12 | 532121246 | Bracket, Mounting Switch |
| 13 | 532121248 | Bushing, Snap |
| 14 | 872050411 | Bolt, Carriage 1/4-20 X 1-3/8 |
| 15 | 532121249 | Spacer, Split |
| 16 | 532123740 | Spring, Cprsn |
| 17 | 532123976 | Nut, Lock 1/4 Lge Flg Gr. 5 |
| 18 | 819171912 | Washer 17/32 X 1-3/16 X 12 Ga. |
| 19 | 532120068 | Knob, Seat 1/2-13 Unc |
| 20 | 532124238 | Cap, Spring Seat |
| 21 | 532139888 | Bolt, Shoulder 5/16-18 Unc |
| 22 | 873680500 | Nut, Crownlock 5/16-18 Unc |

NOTE: All component dimensions given in U.S. inches
1 inch = 25.4 mm

REPAIR PARTS

TRACTOR - - MODEL NO. GTH200 (954002022A)

TRANSAXLE HYDRO GEAR MODEL NUMBER 210-3010

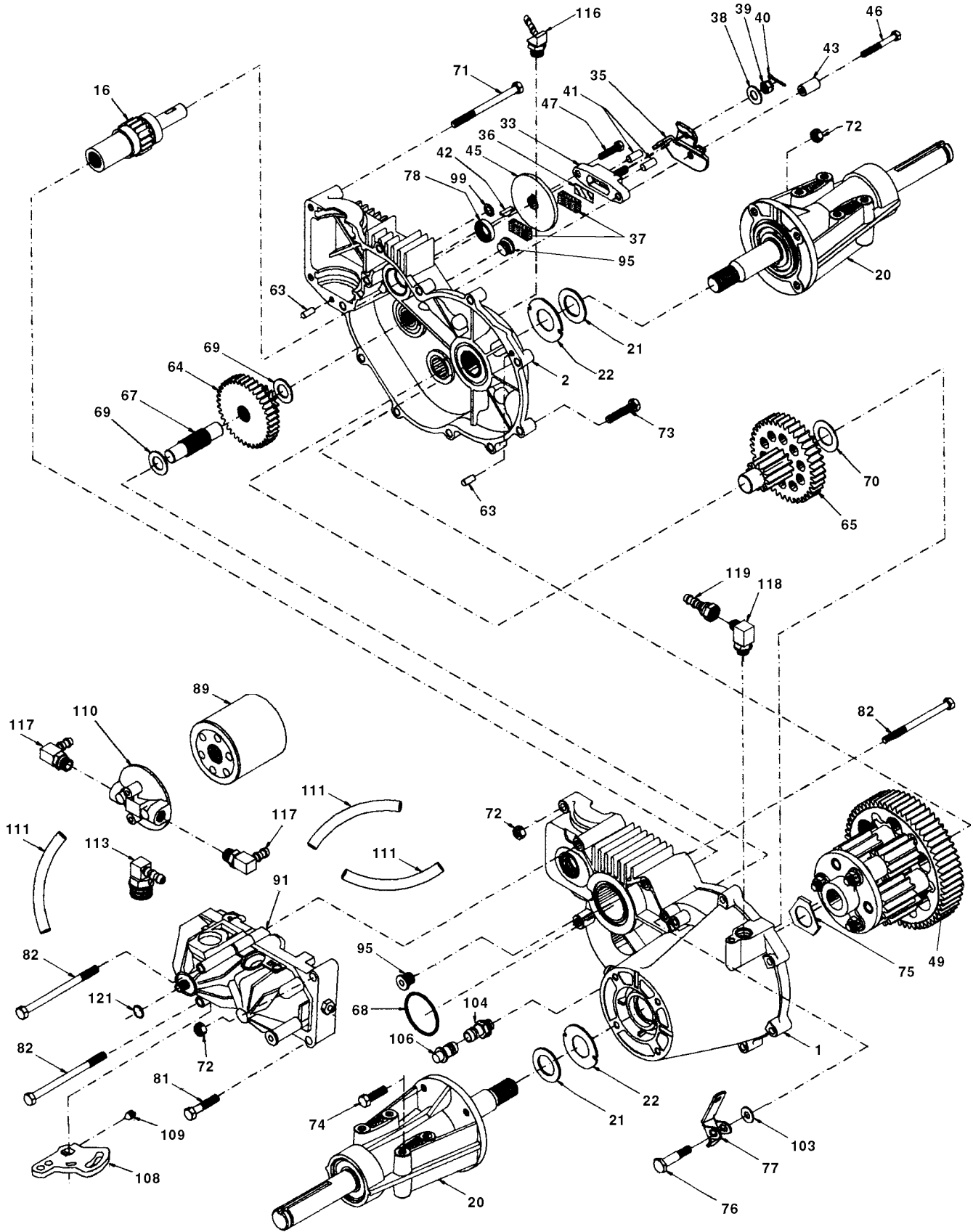

REPAIR PARTS

TRACTOR - - MODEL NO. GTH200 (954002022A)

TRANSAXLE HYDRO GEAR MODEL NUMBER 210-3010

| ITEM NO. | AYP PART NO. | DESCRIPTION | ITEM NO. | AYP PART NO. | DESCRIPTION |
|----------|--------------|--------------------------|----------|--------------|---------------------------------|
| 1 | 532142874 | Assembly, Lh Housing | 71 | 532142902 | Bolt, Hex 5/16-18 X 3.5 |
| 2 | 532142875 | Assembly, Rh Housing | 72 | 532142903 | Hex Lock Nut, 5/16-18 |
| 16 | 532142876 | Brake Shaft Assembly | 73 | 532142904 | Bolt, Hex 5/16-18 X 1-1/2 |
| 20 | 532142877 | Axle Mounting Horn Ass'y | 74 | 532142905 | Hex Cap Screw, 5/16-18 X 1 |
| 21 | 532142878 | Washer, 1.0x1.63x.08 | 75 | 532142906 | Washer, Differential |
| 22 | 532142879 | Washer, 1.0x2.06x.09 | 76 | 532142907 | Shoulder Bolt |
| 33 | 532142929 | Brake Yoke Assembly | 77 | 532142908 | Freewheel Actuating Arm |
| 35 | 532142880 | Brake Arm | 78 | 532142909 | Oil Seal, .625 X 1.0 X .25 |
| 36 | 532142882 | Puck Plate | 81 | 532142910 | Bolt, Hex 5/16-18 X 1-3/4 |
| 37 | 532142883 | Brake Puck | 82 | 532142911 | Bolt, 5/16-18 X 4-1/2 |
| 38 | 532142884 | Washer, 7/8odx7/16x.060 | 89 | 532142912 | Spin On Filter |
| 39 | 532142885 | Castle Nut, 5/16-24 | 91 | 532142913 | Bdu-10I-118 |
| 40 | 532142886 | Cotter Pin | 95 | 532142914 | Straight Thread Plug |
| 41 | 532142887 | Brake Actuating Pin | 99 | 532142915 | Washer, 11/32 X 9/16 |
| 42 | 532142888 | Hi Pro Key | 103 | 532142916 | Washer |
| 43 | 532142889 | Spacer | 104 | 532142917 | Cap-Vent Assembly |
| 45 | 532142890 | Brake Disc | 106 | 532142918 | Fitting-O Ring Assembly |
| 46 | 532142891 | Bolt, 1/4-20 X 1-1/2 | 108 | 532142919 | Control Arm |
| 47 | 532142892 | Bolt, 1/4-20 X 1 | 109 | 532142920 | Set Screw |
| 49 | 532142893 | Differential Assembly | 110 | 532142921 | Filter Head |
| 63 | 532142894 | Dowel Pin | 111 | 532142922 | Hose, 5/16 X 12" Long |
| 64 | 532142896 | 14t-38t Reduction Gear | 113 | 532142923 | 90° 7/8 Sae Fitting |
| 65 | 532142897 | Final Drive Pinion Ass'y | 116 | 532142924 | 45° 9/16 Sae Fitting |
| 67 | 532142898 | Jack Shaft | 117 | 532142925 | 90° 9/16 Sae Fitting |
| 68 | 532142899 | O Ring | 118 | 532142926 | 90° Sae #6 Flare Male Fitting |
| 69 | 532142900 | Washer, 5/8 X 1-5/32 | 119 | 532142927 | 90° Sae #6 Flare Female Fitting |
| 70 | 532142901 | Washer, 7/8 X 1-1/2 | 121 | 532142928 | Wire Retaining Ring |

REPAIR PARTS

TRACTOR - - MODEL NO. GTH200 (954002022A)

TRANSAXLE PUMP- - MODEL NUMBER BDU-10L-118

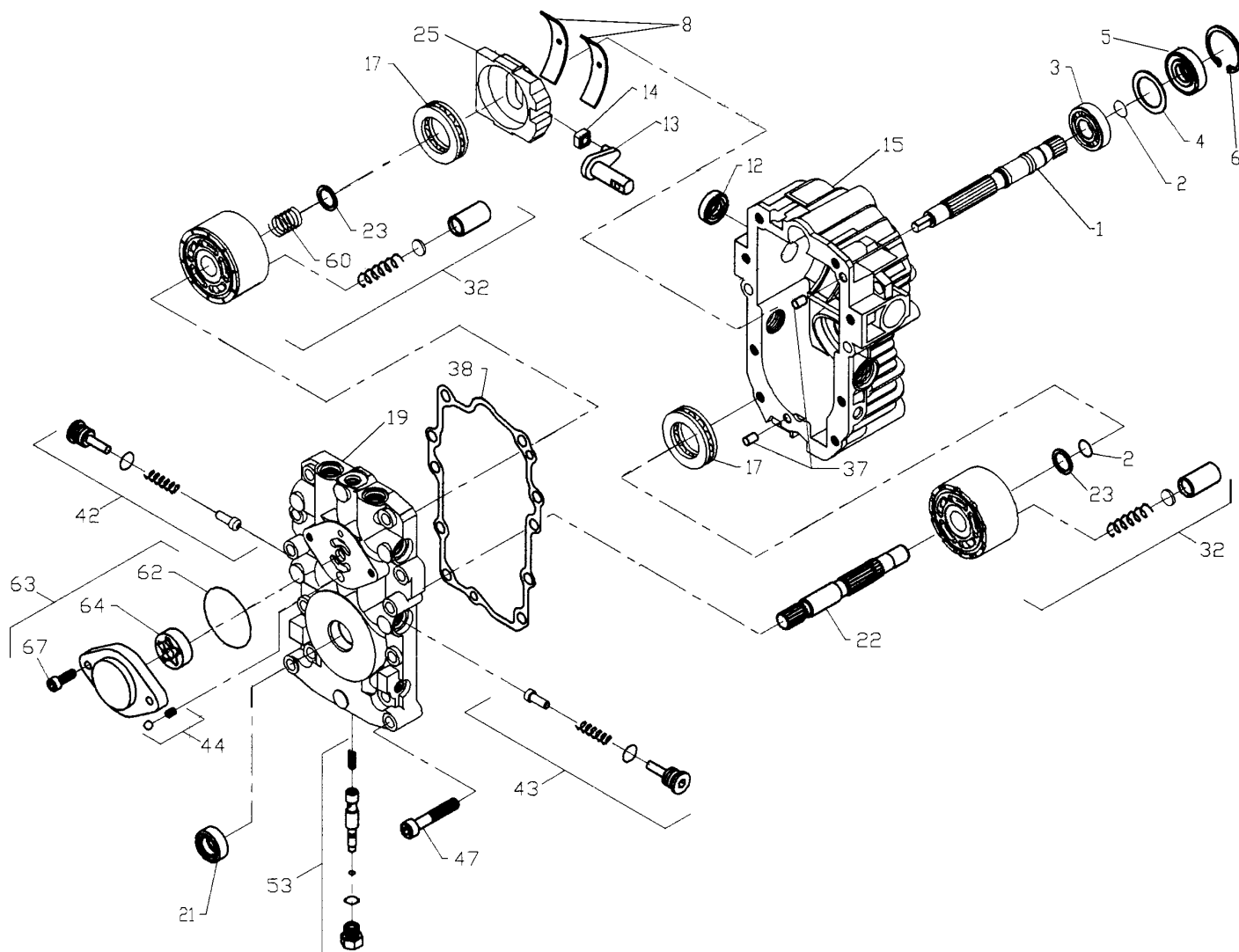

KEY PART NO. NO.

DESCRIPTION

| | | |
|----|-----------|---------------------------|
| 1 | 532144569 | Shaft, Pump |
| 2 | 532122716 | Ring, Retaining |
| 3 | 532122745 | Bearing, Ball |
| 4 | 532122715 | Spacer |
| 5 | 532122700 | Seal, Lip |
| 6 | 532122699 | Ring, Retaining |
| 8 | 532122767 | Bearing, Cradle |
| 12 | 532122717 | Seal, Lip |
| 13 | 532122748 | Arm, Trunnion |
| 14 | 532122749 | Guide, Slot |
| 15 | 532144571 | Housing Kit, Transmission |
| 17 | 532122770 | Bearing, Thrust, Ball |
| 19 | 532144572 | Center Section Kit |
| 21 | 532122722 | Seal, Lip |
| 22 | 532144573 | Shaft, Motor |
| 23 | 532144574 | Washer, Block Thrust |

KEY PART NO. NO.

DESCRIPTION

| | | |
|----|-----------|--------------------------|
| 25 | 532127148 | Swashplate, Variable |
| 32 | 532144577 | Block Assembly |
| 37 | 532122786 | Pin, Stainless, Headless |
| 38 | 532122718 | Gasket, Center Section |
| 42 | 532144578 | Check Valve Kit |
| 43 | 532144578 | Check Valve Kit |
| 44 | 532144579 | Charge Relief Kit |
| 47 | 532122752 | Screw, Socket Head, Cap |
| 53 | 532127153 | Bypass Valve Kit |
| 60 | 532144580 | Block Spring |
| 62 | 532144581 | O-Ring |
| 63 | 532144582 | Charge Pump Kit |
| 64 | 532144583 | Gerotor Assembly |
| 67 | 532144584 | Screw, Socket Head, Cap |
| -- | 532144576 | Pump Assembly, Complete |