

# LTH 120

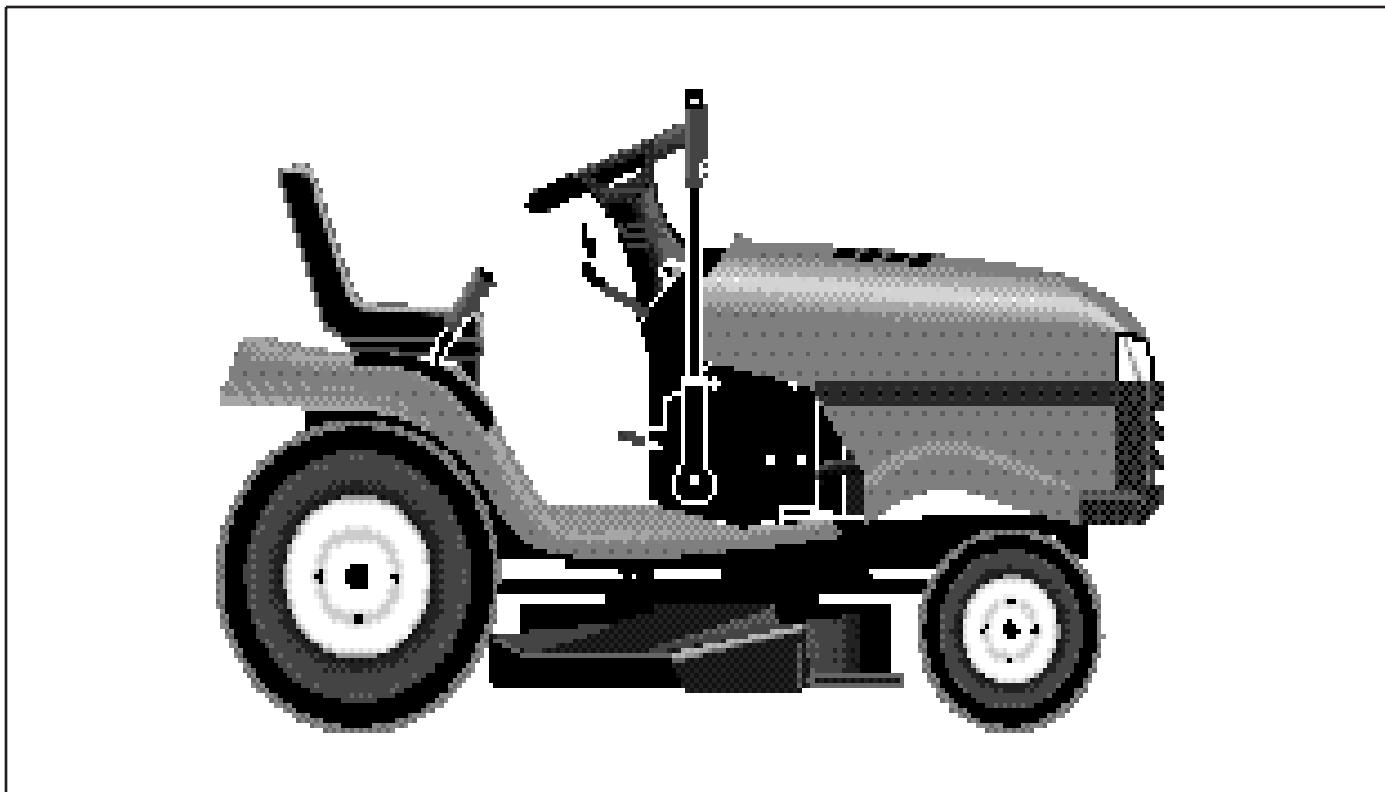

**1.1997**  
**Spare Parts**

**954 14 00-03A**

# TRACTOR - MODEL NO. LTH120 (954140003A), PRODUCT NO. 954 1400-03

## SCHEMATIC

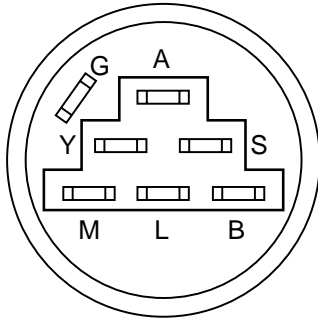
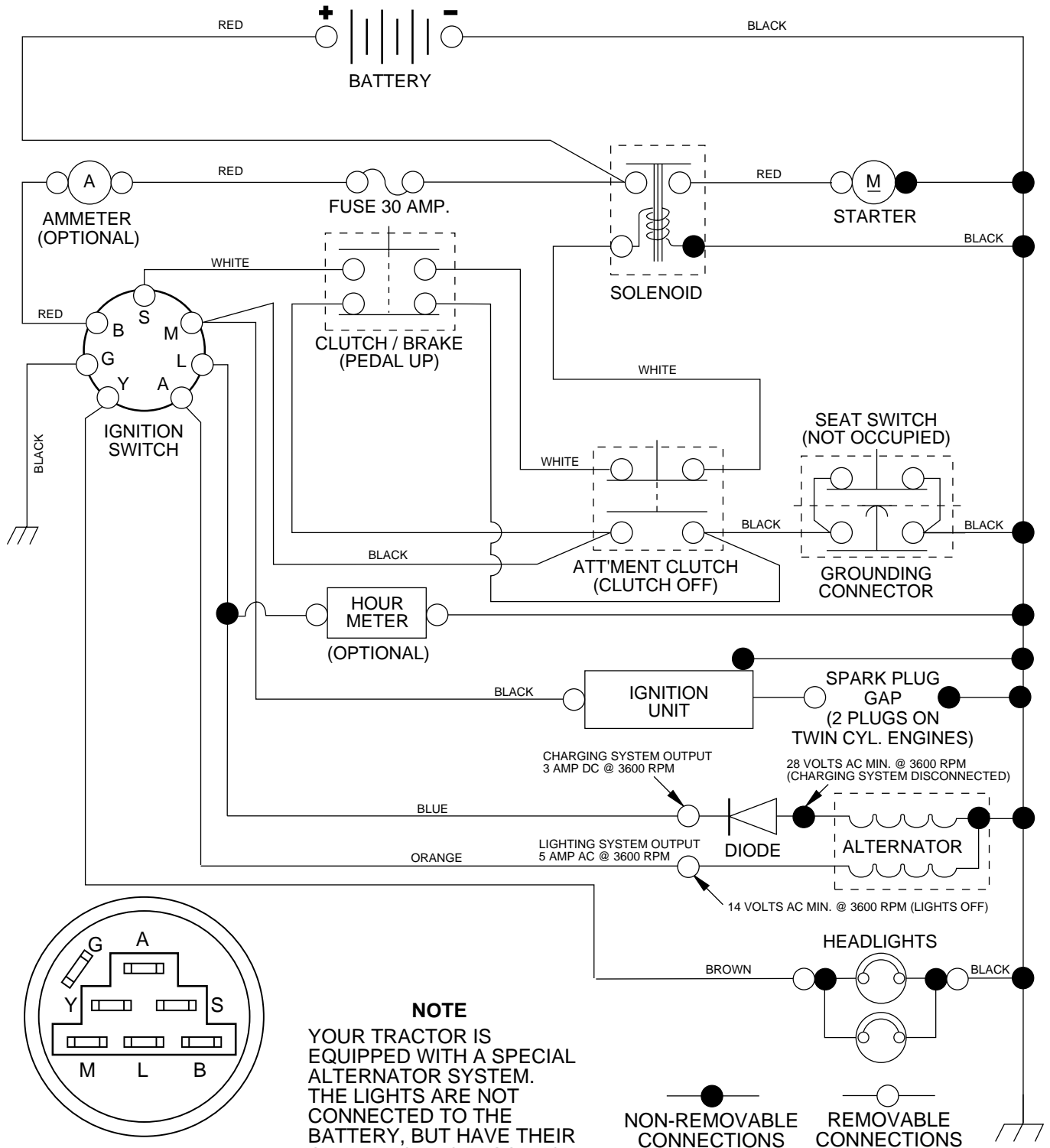

**IGNITION SWITCH**

POSITION	CIRCUIT	"MAKE"
OFF	G + M + L	NONE
RUN/LIGHT	B + L	A + Y
RUN	B + L	NONE
START	B + L + S	NONE

**NOTE**

YOUR TRACTOR IS EQUIPPED WITH A SPECIAL ALTERNATOR SYSTEM. THE LIGHTS ARE NOT CONNECTED TO THE BATTERY, BUT HAVE THEIR OWN ELECTRICAL SOURCE. BECAUSE OF THIS, THE BRIGHTNESS OF THE LIGHTS WILL CHANGE WITH ENGINE SPEED. AT IDLE THE LIGHTS WILL DIM. AS THE ENGINE IS SPEEDED UP, THE LIGHTS WILL BECOME THEIR BRIGHTEST.

NON-REMOVABLE CONNECTIONS      REMOVABLE CONNECTIONS

**WIRING INSULATED CLIPS**

**NOTE:** IF WIRING INSULATED CLIPS WERE REMOVED FOR SERVICING OF UNIT, THEY SHOULD BE REPLACED TO PROPERLY SECURE YOUR WIRING.

# REPAIR PARTS

TRACTOR - MODEL NO. LTH120 (954140003A), PRODUCT NO. 954 1400-03

## ELECTRICAL

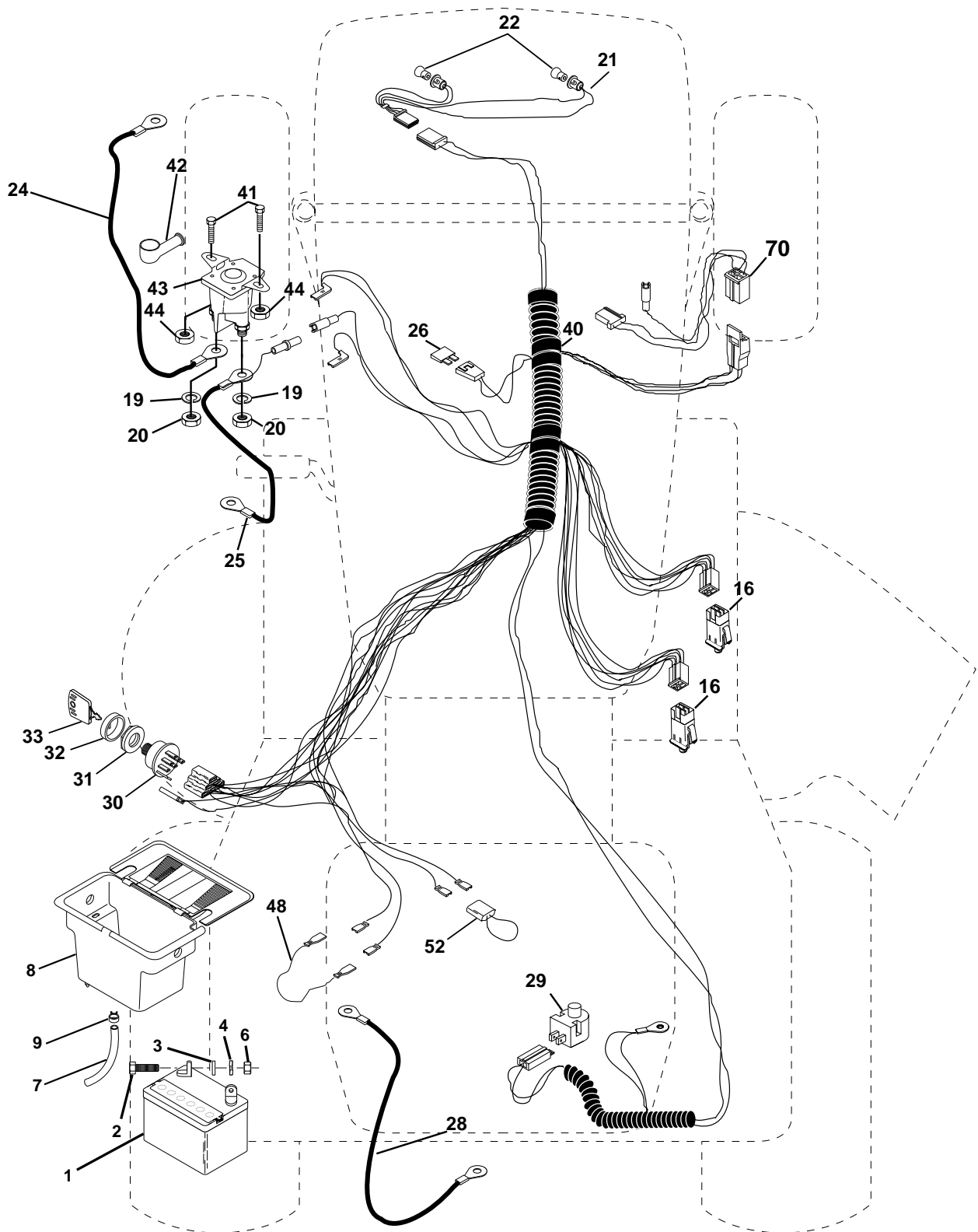

# REPAIR PARTS

TRACTOR - MODEL NO. LTH120 (954140003A), PRODUCT NO. 954 1400-03

## ELECTRICAL

KEY NO.	PART NO.	DESCRIPTION
1	532 14 61-39	Battery 12 Volt 25 AMP
2	874 76 04-12	Bolt Hex Hd 1/4-20unc X 3/4
3	819 09 10-16	Washer 9/32 X 5/8 X 16 Ga.
4	810 04 04-00	Washer Lock Hvy Helical 1/4
6	873 22 04-00	Nut Fin Hex 1/4-20 Unc
7	532 10 92-38	Tube Plastic 12"
8	532 15 64-17	Case Battery Mech Hinge
9	532 10 95-96	Clamp Hose Olive
16	532 15 36-64	Switch Interlock Push-In
19	810 09 04-00	Washer Lock 1/4
20	873 35 04-00	Nut Jam Hex 1/4-20 Unc
21	532 13 68-50	Harness Asm Light W/4152j
22	532 00 41-52	Bulb Light #1156
24	532 12 47-80	Cable Battery 6 Ga 11" red
25	532 14 61-47	Cable Battery 6 Ga 44" red w/16 wire
26	532 10 88-24	Fuse 30 AMP Auto Green
28	532 12 47-73	Cable Ground 6 Ga 12" black
29	532 12 13-05	Switch Plunger Nc Gray
30	532 14 03-01	Switch Ign 4 pos w/lights
31	532 12 42-11	Nut Ignition
32	532 14 12-26	Cover Sw Ignition
33	532 12 21-47	Key Ign Modelled Generic
40	532 15 64-42	Harness Ign.
41	871 11 04-08	Bolt Blk Fin Hex 1/4 - 20 x 1/2
42	532 13 15-63	Cover Terminal Red
43	532 14 56-73	Solenoid
44	873 64 04-00	Nut Keps Hex 1/4-20 Unc
48	532 14 08-44	Adapter Ammeter Rectangular
52	532 14 19-40	Protection Wire Loop
70	532 14 04-13	Harness, Eng. B&S/Tec Dual

**NOTE:** All component dimensions given in U.S. inches.  
1 inch = 25.4 mm.

# REPAIR PARTS

TRACTOR - MODEL NO. LTH120 (954140003A), PRODUCT NO. 954 1400-03  
CHASSIS AND ENCLOSURES

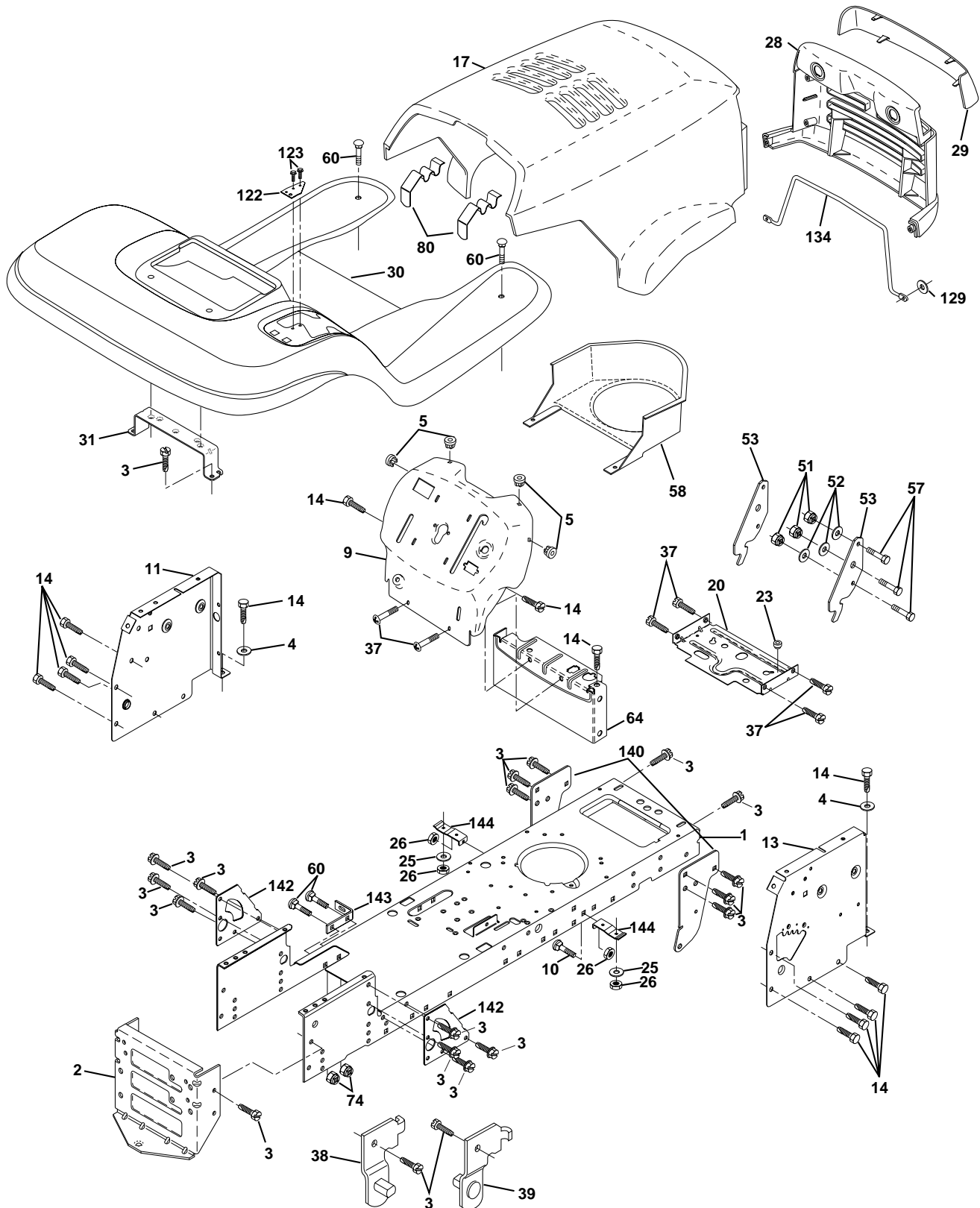

# REPAIR PARTS

TRACTOR - MODEL NO. LTH120 (954140003A), PRODUCT NO. 954 1400-03

## CHASSIS AND ENCLOSURES

KEY NO.	PART NO.	DESCRIPTION
1	532 15 38-71	Chassis Weldment
2	532 14 03-56	Drawbar, Stretch
3	817 49 06-12	Screw Thdrol 3/8-16x3/4 Ty-tt
4	819 13 12-16	Washer 13/32 x 3/4 x 16 Ga.
5	532 15 52-72	Bumper Hood/Dash
9	532 15 72-61	Dash P/L M, N/AMM N/HM Grey
10	872 14 06-08	Bolt Carriage 3/8-16 x 1
11	532 15 59-27	Panel Dash Lh
13	532 15 72-62	Panel Dash Rh
14	817 49 06-08	Screw Thdrol 3/8-16x1/2 Ty-tt
17	532 15 60-51	Hood LT/PL Husqvarna
20	532 15 64-37	Plate Mtg Battery Fuel Tank Fr
23	532 12 40-28	Bushing
25	819 13 13-12	Washer 13/32 X 13/16 X 12 Ga
26	873 80 06-00	Nut Lock Hex W/Ins 3/8-16 Unc
28	532 14 97-76	Grille LT/PL Husqvarna
29	532 14 97-77	Lens LT/PL Husqvarna
30	532 15 64-89	Fender Footrest STLT Pnt
31	532 13 99-76	Bracket Support Fender
37	817 49 05-08	Screw Thdrol 6/16-18 x 1/2 TYT
38	532 13 98-86	Bracket, Asm. Pivot, L.H., Mower Rear
39	532 13 98-87	Bracket, Asm. Pivot, R.H., Mower Rear
51	873 80 04-00	Nut Lock Hex W/Ins 1/4-20
52	819 09 14-16	Washer 9/32 x 7/8 x 16 Ga.
53	532 15 00-67	Bracket Pnt. Pick off LT/PL Husqvarna
57	874 78 04-12	Bolt Hex 1/4-20 x 3/4
58	532 15 01-27	Air Duct Engine P/L
60	872 14 06-06	Bolt Rdhd Sqnk 3/8-16unc x 3/4
64	532 15 47-98	Dash Lower STLT
74	873 68 06-00	Nut Crownlock 3/8-16 UNC
80	532 15 58-54	Latch Hood Plm Husqvarna
129	819 09 10-16	Washer 9/32 x 5/8 x 16 Ga.
134	532 15 01-32	Rod Support Hood LT/PL Husq.
140	532 15 05-56	Bracket Chassis Front 7 Ga.
142	532 15 60-95	Plate Reinforcement STLT
143	532 15 49-66	Bracket Swaybar Chassis
144	532 15 42-07	Bracket Pnt Footrest STLT
146	532 15 43-34	Screw Torx Hd Thd 5/16-18 UN-2A
--	532 00 54-79	Plug Button

**NOTE:** All component dimensions given in U.S. inches  
1 inch = 25.4 mm

# REPAIR PARTS

TRACTOR - MODEL NO. LTH120 (954140003A), PRODUCT NO. 954 1400-03

## DRIVE

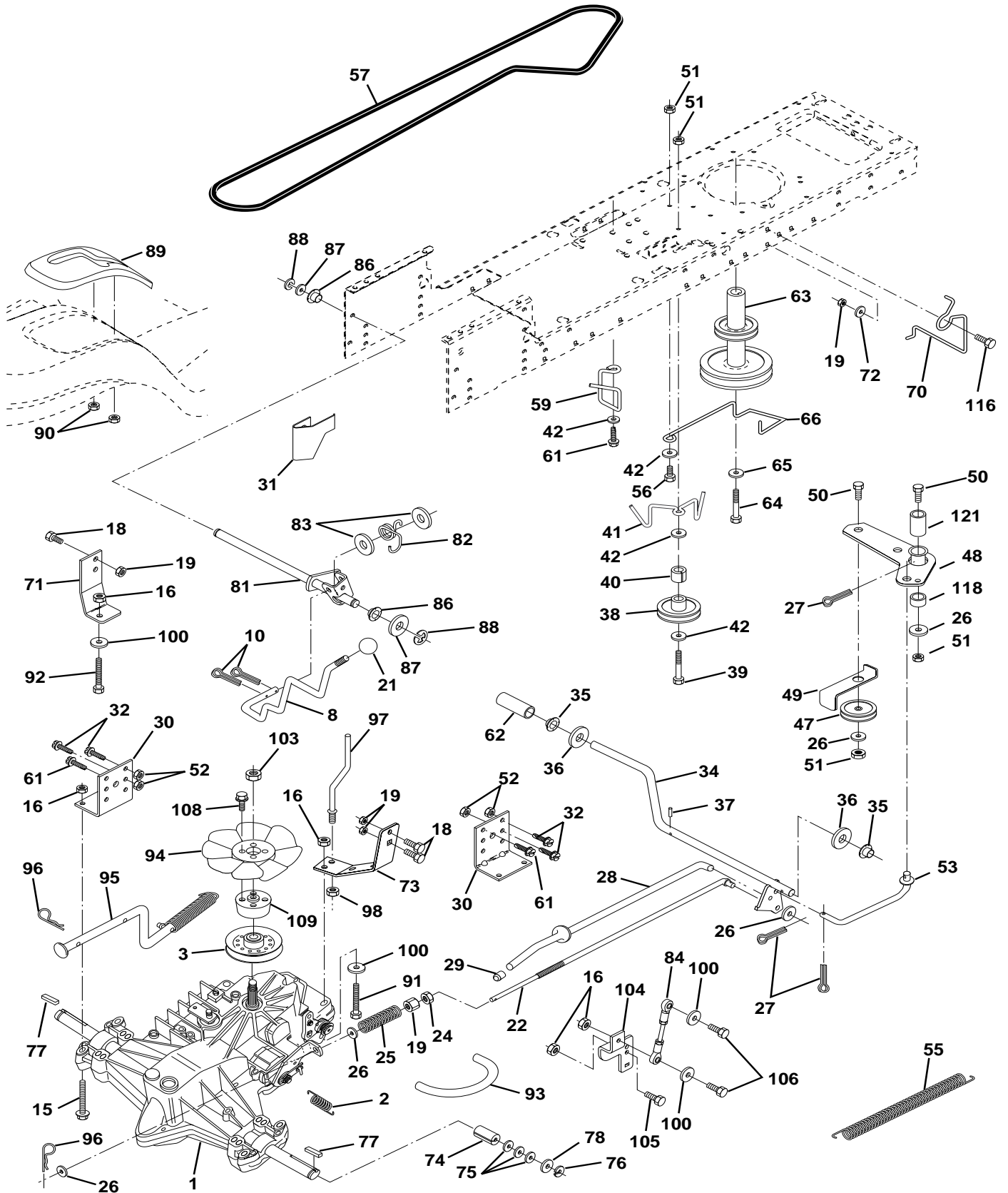

# REPAIR PARTS

TRACTOR - MODEL NO. LTH120 (954140003A), PRODUCT NO. 954 1400-03

## DRIVE

KEY NO.	PART NO.	DESCRIPTION	KEY NO.	PART NO.	DESCRIPTION
1	532 14 06-07	Transaxle Assembly	64	871 17 07-64	Bolt, Hex
2	532 14 24-31	Spring, Return, Brake	65	810 04 07-00	Washer
3	532 14 46-98	Pulley, Transaxle	66	532 15 47-78	Keeper, Belt Engine Flproof
8	532 15 47-92	Rod Shift Fender STLT	70	532 13 46-83	Keeper Belt Engine
10	876 02 04-16	Pin Cotter 1/8 x 1 CAD	71	532 14 14-17	Strap Torque Lh Hydro 500 18"
15	874 49 05-44	Bolt Hex Flghd 5/16-18 Gr 5	72	819 13 20-12	Washer 13/32 x 1-1/4 x 12 Gauge
16	873 80 05-00	Nut Lock Hex W/Ins 5/16-18 Unc P	73	532 14 14-18	Strap Torque Rh Hydro 500 18"
18	874 78 06-16	Bolt Fin Hex 3/8-16 Unc x 1 Gr. 5	74	532 12 11-99	Spacer, Split
19	873 80 06-00	Nut Lock Hex W/Wsh 3/8-16 Unc	75	532 12 17-49	Washer 25/32 x 1-1/4 x 16 Gauge
21	532 10 69-33	Knob 1/2-13	76	812 00 00-01	E-Ring
22	532 14 56-27	Rod, Brake Hydro	77	532 12 35-83	Key, Square
24	873 35 06-00	Nut	78	532 12 17-48	Washer 25/32 x 1-5/8 x 16 Gauge
25	532 10 68-88	Spring, Brake Rod	81	532 15 60-48	Shaft Asm. Cross Hydro 500
26	819 13 13-16	Washer	82	532 12 37-82	Spring Torsion T/A
27	876 02 04-12	Pin Cotter 1/8 x 3/4 CAD.	83	819 17 12-16	Washer 17/32 x 3/4 x 16 Ga.
28	532 14 52-04	Rod, Parking Brake	84	532 14 14-23	Rod, Tie Hydro Sph Ball 500
29	532 07 16-73	Cap, Parking Brake	86	532 07 12-08	Bushing Rod Strig. 629/632 ID
30	532 13 08-07	Bracket, Transaxle	87	819 21 20-16	Washer 21/32 x 1-1/4 x 16 Ga.
31	532 12 72-75	Keeper Belt Lh	88	812 00 00-08	Ring Klip #5304-62
32	874 76 05-12	Bolt Hex Hd 5/16-18 Unc x 3/4	89	532 15 48-82	Console, Shift Hydro STLT
34	532 15 50-71	Shaft, Foot Pedal	90	532 12 43-46	Nut Self-Thd Wsh-Hd 1/4 Zinc
35	532 12 01-83	Bearing, Nylon	91	874 78 05-36	Bolt Fin Hex 5/16-18 x 2-1/4
36	819 21 16-16	Washer	92	874 78 05-24	Bolt Fin Hex 5/6-18 Unc x 1-1/2
37	532 12 49-63	Pin, Roll	93	532 14 25-64	Line Fuel Hydro 4"
38	532 12 36-74	Pulley, Idler, Flat	94	532 14 04-62	Fan, Hydro 7"
39	874 76 06-44	Bolt	95	532 14 46-43	Control Asm. Bypass Hydro
40	532 12 49-65	Spacer, Split	96	532 12 47-88	Retainer Spring 1" Zinc/Cad
41	532 15 47-77	Keeper, Belt Retainer	97	532 14 42-01	Keeper Belt Rh Hydro 500
42	819 13 13-12	Washer 13/32 x 13/16 x 12 Gauge	98	873 51 06-00	Nut Keps Hex 3/8-16 Unc
47	532 12 77-83	Pulley, Idler, V-Groove	100	819 11 12-16	Washer 11/32 x 3/4 x 16 Ga.
48	532 15 44-07	Bellcrank Assembly	103	873 94 08-00	Nut, Hex Jam Toplock 1/2-20 Unf
49	532 12 32-05	Retainer, Belt	104	532 14 14-21	Arm, Control Pump
50	874 76 06-24	Bolt	105	871 07 05-16	Screw Cap Hex 5/16 x 18 x 1
51	873 68 06-00	Nut Crownlock 3/8-16	106	874 78 05-20	Bolt Fin Hex 5/16-18 Unc x 1-1/4
52	873 68 05-00	Nut Crownlock 5/16-18	108	817 54 10-26	Screw Hex Wh Hd #10-24 x 1-5/8
53	532 10 57-10	Link, Clutch	109	532 14 50-98	Adaptor Fan/Hydro Lt Hyd Alum
55	532 10 57-09	Spring, Return, Clutch	116	872 11 06-10	Bolt, RDHD SQ Neck 3/8-16 x 1.25
56	874 76 06-20	Bolt Fin Hex 3/8-16 Unc x 1-1/4	118	532 15 47-74	Spacer Bellcrank
57	532 14 14-16	V-Belt, Ground Drive	121	532 15 44-19	Nyliner Clutching STL
59	532 14 03-12	Keeper, Center Span			
61	817 49 06-12	Screw Thdrol. 3/8-16 x 3/4 Ty. TT			
62	532 12 48-72	Cover, Pedal			
63	532 14 01-86	Pulley, Engine			

**NOTE:** All component dimensions give in U.S. inches.  
1 inch = 25.4 mm.



# REPAIR PARTS

TRACTOR - MODEL NO. LTH120 (954140003A), PRODUCT NO. 954 1400-03

## STEERING ASSEMBLY

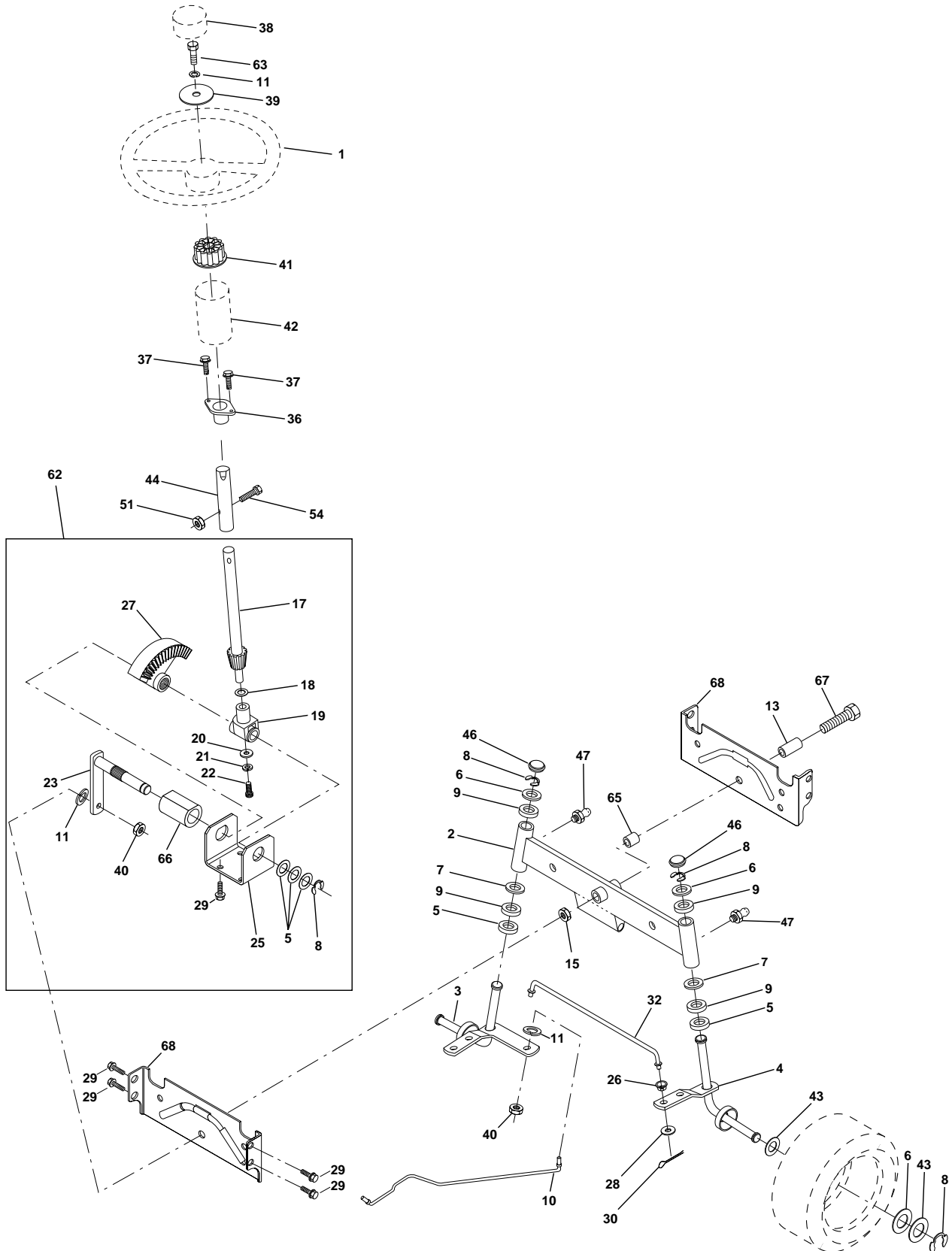

# REPAIR PARTS

TRACTOR - MODEL NO. LTH120 (954140003A), PRODUCT NO. 954 1400-03

## STEERING ASSEMBLY

KEY NO.	PART NO.	DESCRIPTION
1	532 12 44-15	Wheel Steering
2	532 15 44-27	Axle Asm STMP Dropped STL
3	532 15 44-22	Spindle Asm LH
4	532 15 44-23	Spindle Asm RH
5	532 12 49-31	Bearing Race Thrust Harden
6	532 12 17-48	Washer 25/32 X 1-5/8 X 16 Ga
7	819 27 20-16	Washer 27/32 X 1-1/4 X 16 Ga
8	812 00 00-29	Ring Klip #t5304-75
9	532 12 49-37	Bearing Col Strg Blk
10	532 15 64-38	Link Drag Extended Stamp
11	810 04 06-00	Washer Lock Hvy Hlcl Spr 3/8
13	532 15 47-79	Bearing Axle STLT/GT
15	873 90 10-00	Nut Lock Flange 5/8-11 Unc
17	532 15 65-46	Shaft Asm Strg
18	532 05 70-79	Washer Thrust 515x 750x 033
19	532 12 40-35	Support Shaft
20	532 12 66-84	Washer Shim 1/4 X 5/8 X 062
21	810 04 04-00	Washer Lock Hvy Helical 1/4
22	871 10 04-10	Screw Cap Sckt Hd Phos & Oil
23	532 12 75-01	Shaft Asm Pittman
25	532 15 44-06	Bracket Steering
26	543 12 68-47	Bushing Link Drag Blk LR
27	532 13 68-74	Gear Sector
28	819 13 14-16	Washer 13/32 X 7/8 X 16 Ga
29	817 49 06-12	Screw Thdrol 3/8-16x3/4 Ty-tt
30	876 02 04-12	Pin Cotter 1/8 X 3/4 Cad
32	532 13 04-65	Rod Tie Wire Form 19 75 Mech
36	532 15 50-99	Bushing Strg
37	532 15 29-27	Screw
38	532 12 44-16	Insert Cap Strg Wh Au
39	819 13 38-08	Washer 13/32 X 2-3/8 X 8 Ga
40	532 12 47-01	Lock nut
41	532 10 07-11	Adaptor Wheel Strg
42	532 15 50-92	Boot Steering Shaft
43	532 12 17-49	Washer 25/32 X 1 1/4 X 16 Ga
44	532 15 37-20	Extension Steering Shaft LR/LT
46	532 12 12-32	Cap Spindle Fr Top Blk
47	532 12 48-36	Fitting Grease
51	873 80 05-00	Nut Lock Hex w/Ins 5/16-18
54	874 78 05-20	Bolt Fin Hex 5/16-18 Unc x 1-1/4
62	532 15 65-94	Kit, Steering Assembly Svc
63	874 78 06-16	Bolt Fin Hex 3/8-16unc x 1 Gr. 5
65	532 15 47-80	Spacer Axle
66	532 15 44-04	Bearing Arm Pittman
67	874 78 10-44	Bolt, Fin Hex 5/8-11 UNC x 2-3/4
68	532 15 44-29	Axle, Brace

**NOTE:** All component dimensions given in U.S. inches.  
1 inch = 25.4 mm.

# REPAIR PARTS

TRACTOR - MODEL NO. LTH120 (954140003A), PRODUCT NO. 954 1400-03

## SEAT ASSEMBLY

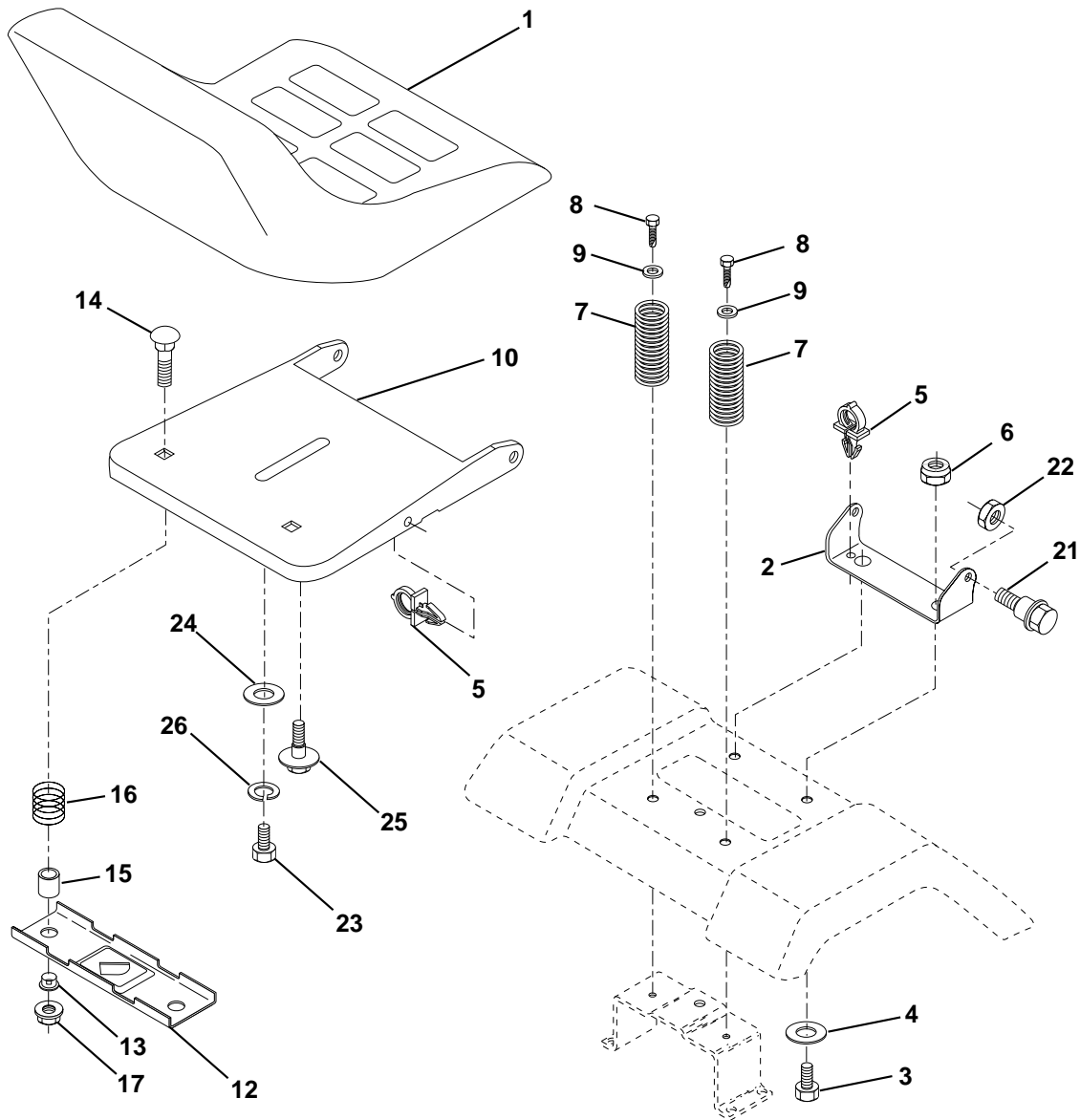

### KEY PART NO. NO.

### DESCRIPTION

1	532 14 08-38	Seat
2	532 14 05-51	Bracket Pivot Seat 8 720
3	874 76 06-16	Bolt Fin Hex 3/8-16unc X 1
4	819 13 16-10	Washer 13/32 X 1 X 10 Ga
5	532 14 50-06	Clip Push-In
6	873 80 06-00	Nut Hex w/Ins. 3/8-16 Unc
7	532 12 41-81	Spring Seat Cprsn 2 250 Blk Zi
8	817 49 06-16	Screw Thdrol 3/8-16 X 1 Ty-tt
9	819 13 16-14	Washer 13/32 X 1 X 14 Ga.
10	532 15 59-25	Pan Seat
12	532 12 12-46	Bracket Mounting Switch
13	532 12 12-48	Bushing Snap Blk Nyl 50 Id

### KEY PART NO. NO.

### DESCRIPTION

14	872 05 04-11	Bolt Rdhd Sqnk 1/4-20x1-3/8
15	532 13 43-00	Spacer Split 28x 96 Yel Zinc
16	532 12 12-50	Spring Cprsn 1 27 Blk Pnt
17	532 12 39-76	Nut Lock 1/4 Lge Flg Gr 5 Zinc
21	532 15 32-36	Bolt Shoulder 5/16-18 Unc
22	873 80 05-00	Nut Hex Lock W/Ins 5/16-18
23	874 78 08-14	Bolt, Hex Head, Fin 1/2-13 x 7/8 Grade 5
24	819 17 19-12	Washer 17/32 X 1-3/16 X 12 Ga.
25	532 12 70-18	Bolt Shoulder 5/16-18 X 62
26	810 04 08-00	Washer Lock

**NOTE:** All component dimensions given in U.S. inches.  
1 inch = 25.4 mm

# REPAIR PARTS

TRACTOR - MODEL NO. LTH120 (954140003A), PRODUCT NO. 954 1400-03

## DECALS

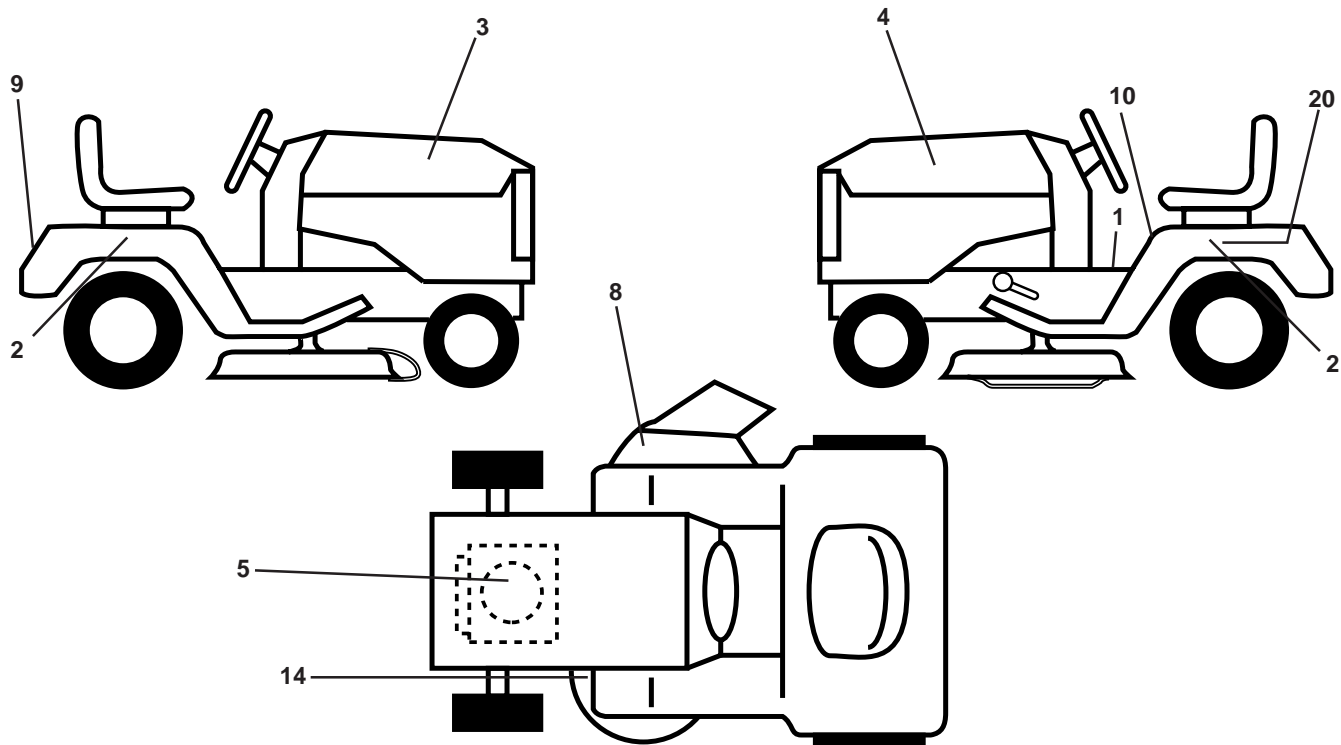

KEY NO.	PART NO.	DESCRIPTION
1	532 15 70-32	Decal Oper. Step Thru Eng/Fr
2	532 15 70-07	Decal Fender Auto Husq Radius
3	532 15 71-95	Decal Hood LH
4	532 15 71-93	Decal Hood RH
5	532 27 19-67	Decal HP Engine
8	532 13 72-59	Decal Warning
9	532 15 06-17	Decal Fender Husq
10	532 15 71-40	Decal Fender Danger Eng/Fr
14	532 13 68-32	Decal V-Belt Schematic
20	532 14 64-51	Decal Bat Dan/Psn
--	532 15 45-15	Pad Footrest LH STLTL

KEY NO.	PART NO.	DESCRIPTION
--	532 15 45-16	Pad Footrest RH STLTL
--	532 13 83-11	Decal Handle Lft Height Adjust
--	532 14 23-41	Decal Drawbar Cntrl Mvt Hyd
--	532 15 71-81	Manual Owner's (English)
--	532 15 71-82	Manual Owner's (French)

Available accessories not included with tractor:

--	MK380	Mulcher Kit with Blades
--	C38	Grass Catcher

## WHEELS & TIRES

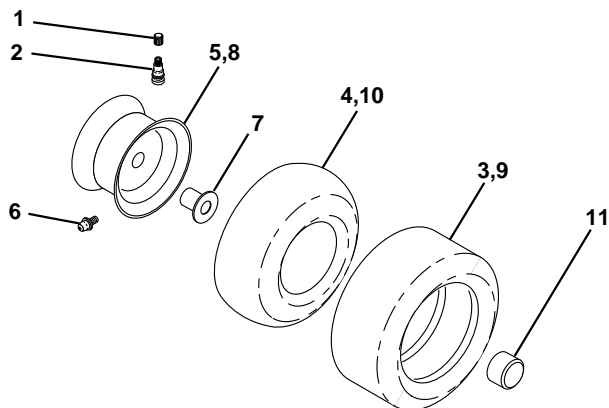

KEY NO.	PART NO.	DESCRIPTION
1	532 05 91-92	Cap Valve Tire
2	532 06 51-39	Stem Valve
3	532 10 62-22	Tire F Ts 15 X 6 0 - 6 Service
4	532 05 99-04	Tube Front (Service Item Only)
5	532 13 83-36	Rim Asm 6"front Silver Service
6	532 12 49-57	Fitting Grease (Front Wheel Only)
7	532 12 49-59	Bearing Flange (Front Wheel Only)
8	532 13 83-37	Rim Asm 8"rear Silver Service
9	532 12 46-35	Tire R Ts 18x8 5-8 C Service
10	532 12 49-26	Tube Rear (Service Item Only)
11	532 10 47-57	Cap Axle Blk 1 50 X 1 00
--	532 14 43-34	Sealant, Tire ( 10 oz. Tube)

**NOTE:** All component dimensions given in U.S. inches  
1 inch = 25.4 mm

# REPAIR PARTS

TRACTOR - MODEL NO. LTH120 (954140003A), PRODUCT NO. 954 1400-03

## ENGINE

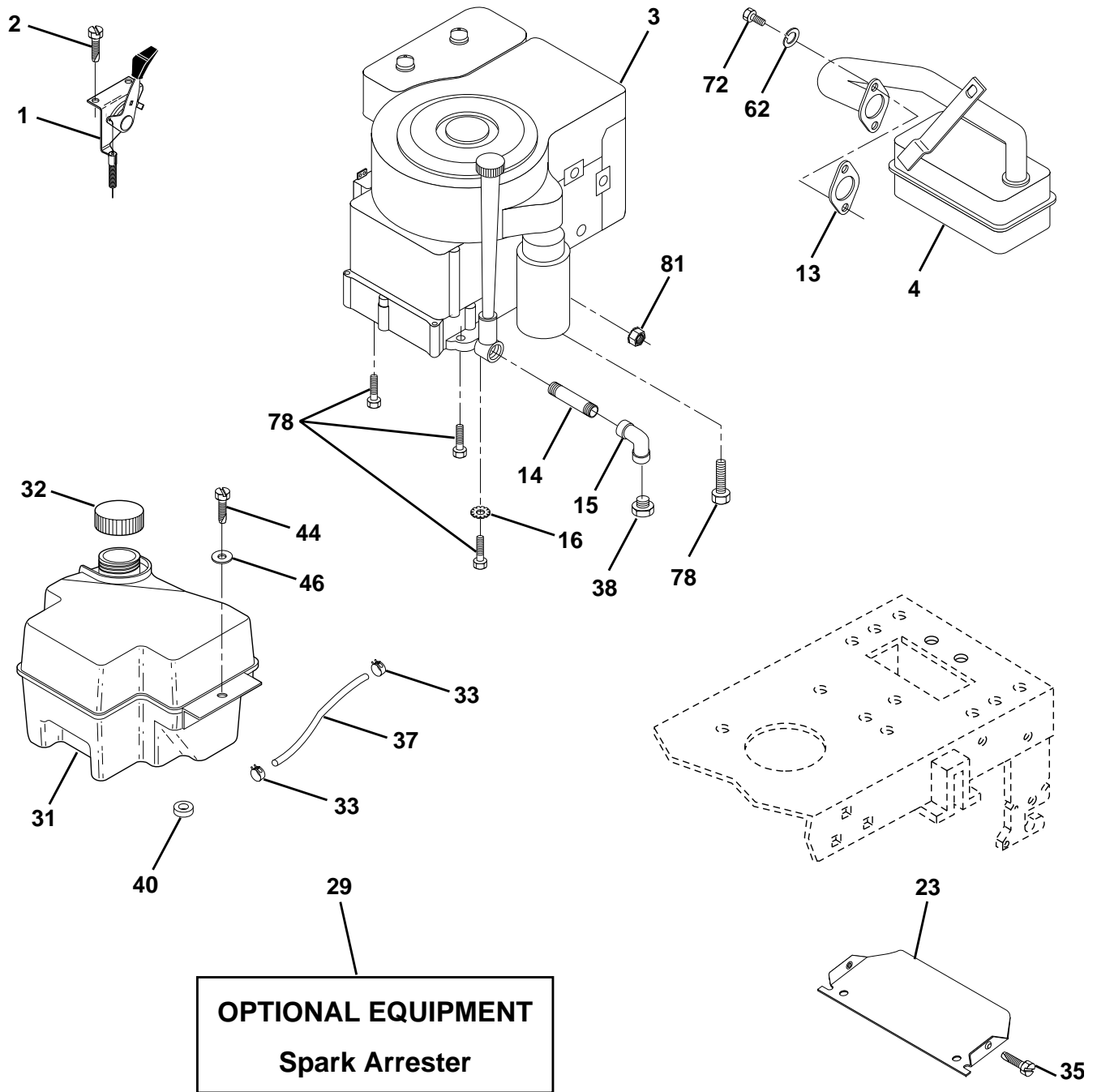

# REPAIR PARTS

TRACTOR - MODEL NO. LTH120 (954140003A), PRODUCT NO. 954 1400-03

## ENGINE

KEY NO.	PART NO.	DESCRIPTION
1	532 14 03-10	Control Th/ch 23 5 LH Flag
2	817 72 04-10	Screw Hex Thd Cut 1/4-20x5/8 T
3	-----	Engine, Briggs 289707
4	532 13 73-48	Muffler LT B&S 12/12.5/13HP
13	532 27 22-93	Gasket Eng 1 313 Id Tin Plated
14	813 28 03-24	Nipple Pipe 3/8 Npt X 3"
15	813 20 03-00	Elbow Std 90 Degree 3/8-18 Npt
16	811 05 06-00	Washer Lock Ext Tooth 3/8
23	532 15 61-23	Shield Heat
29	532 13 71-80	Kit Spark Arrestor (Flat Scrn)
31	532 14 02-80	Tank Fuel Front 2 00
32	532 14 05-27	Cap Asm Fuel W/sym Vented
33	532 12 34-87	Clamp Hose Black
35	817 49 05-12	Screw
37	532 13 70-40	Line Fuel 20"
38	-----	Plug Oil Drain (Order From Engine Manufacturer)
40	532 12 40-28	Bushing Snap Nyl Blk Fuel Line
44	817 49 04-12	Screw Hexwsh Thdrol 1/4-20x3/4
46	819 09 14-16	Washer 9/32 X 7/8 X 16 Ga
62	810 04 05-00	Washer Lock Hvy Hlcl Spr 5/16
72	871 07 05-12	Screw Hexhd Cap 5/16-18x 3/4
78	817 49 06-20	Screw Thdrol 3/8-16x1-1/4 TYTT
81	532 12 88-61	Nut Flange 1/4-20 Starter Nut

**NOTE:** All component dimensions given in U.S. inches  
1 inch = 25.4 mm

# REPAIR PARTS

TRACTOR - MODEL NO. LTH120 (954140003A), PRODUCT NO. 954 1400-03

## MOWER DECK

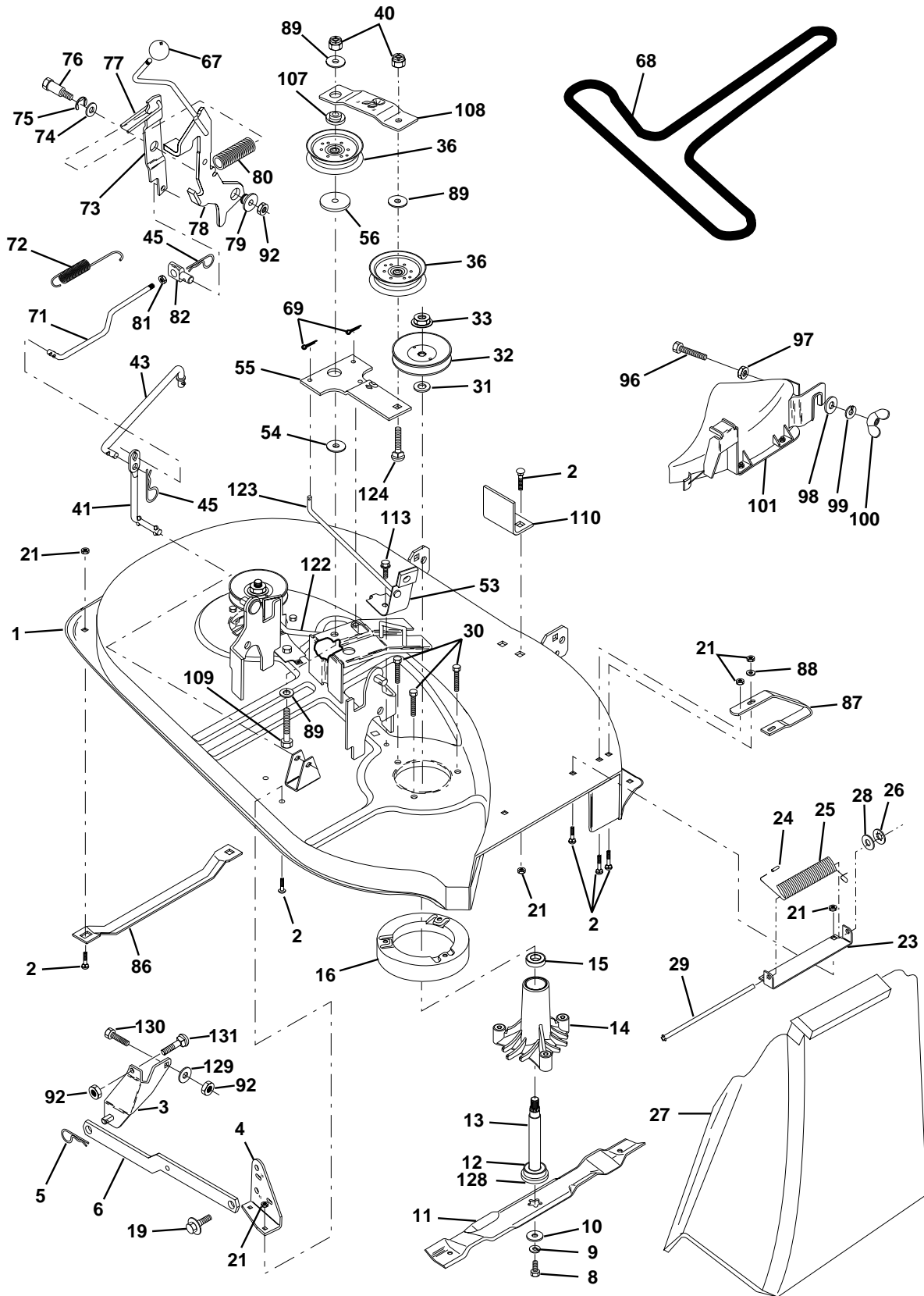

# REPAIR PARTS

TRACTOR - MODEL NO. LTH120 (954140003A), PRODUCT NO. 954 1400-03

## MOWER DECK

KEY NO.	PART NO.	DESCRIPTION	KEY NO.	PART NO.	DESCRIPTION
1	532 14 28-29	Deck Asm Weldment	72	532 13 18-70	Spring Return
2	872 14 05-06	Bolt Rdhd Sqnk 5/16-18unc X3/4	73	532 12 78-47	Arm Clutch Secondary
3	532 13 80-17	Bracket Asm Fr Sway Bar 38/42	74	532 12 17-48	Washer 25/32 X 1-5/8 X 16 Ga
4	532 13 84-40	Bracket Asm Deck Sway Bar	75	812 00 00-29	Ring Klip #5304-75
5	532 12 46-70	Retainer Spring	76	532 12 89-03	Bolt Shoulder 3/8-16 Unc 1 44
6	532 13 08-32	Arm Suspension Rear	77	532 12 78-45	Keeper Spring 4 000
8	532 85 08-57	Bolt 3/8 - 24 X 1.25 Gr 8	78	532 15 48-09	Arm Asm Clutch Primary
9	810 03 06-00	Washer Lock Hvy 3/8	79	532 12 74-98	Bushing 747 Od X 794 Lg Brass
10	532 14 02-96	Washer Hard Blade Mower Vented	80	532 15 37-01	Spring Clutch Mower
11	532 13 41-48	Blade Mower Mulching 38"	81	873 35 06-00	Nut Hex Jam 3/8-16
12	532 12 98-95	Bearing Ball #6024 (Mandrel)	82	532 14 20-28	Trunnion Adj 94
13	532 13 76-45	Shaft Asm W/lower Bearing	86	532 12 50-74	Runner, LH
14	532 12 87-74	Housing Mandrel Vented	87	532 12 87-72	Runner, RH
15	532 11 04-85	Bearing Ball Mandrel	88	819 11 12-16	Washer 11/32 x 3/4 x 16 Ga.
16	532 14 03-29	Stripper Mower Vented	89	819 13 16-12	Washer 13/32 x 1 x 12 Ga.
19	532 13 28-27	Bolt Shoulder	92	873 80 06-00	Nut Lock Hex W/Ins 3/8-16 Unc
21	873 68 05-00	Nut Crownlock 5/16-18 UNC	96	874 93 06-20	Bolt 3/8-16 x 1-1/4 Mulcher
23	532 13 76-07	Bracket Deflector Mower	97	873 93 06-00	Nut Crownlock 3/8-16 UNC
24	532 10 53-04	Cap Sleeve 80x 112 Blk Mower	98	819 13 20-16	Washer 13/32 x 1-1/4 x 16 Ga.
25	532 12 37-13	Spring Torsion Deflector 2 52	99	810 04 06-00	Washer Lock Hvy Hlcl Spr 3/8
26	532 11 04-52	Nut Push Phos & Oil	100	532 13 56-51	Nut Wing
27	532 10 67-36	Shield Deflector	101	532 13 28-03	Cover Asm Mulching 38"
28	819 11 10-16	Washer 11/32 X 5/8 X 16 Ga	107	532 13 35-02	Spacer, Retainer
29	532 10 67-35	Rod Hinge	108	532 13 35-03	Stiffener, Idler Arm
30	532 13 87-76	Screw Thdrol Hex Head Zinc Mwr	109	874 76 06-40	Bolt, Hex Head 3/8-16 x 2-1/2
31	532 12 99-63	Washer Spacer Mower Vented	110	532 14 25-87	Upstop Deck Front 38"
32	532 15 35-32	Pulley Mandrel	113	817 49 05-12	Screw Thdrol 5/16-18 X 3/4
33	532 13 72-66	Nut 9/16 Toplock Fling Oil Dip	122	532 13 12-89	Rod, Brake, LH
36	532 13 14-94	Pulley Idler Flat 3 060	123	532 13 12-88	Rod, Brake, RH
40	873 68 06-00	Nut Crownlock 3/8-16 UNC	124	872 11 06-14	Bolt, Carriage 3/8-16 x 1-3/4
41	532 13 35-51	Rod Pivot W/nibs	128	532 15 33-90	Washer Felt
43	532 13 35-04	Rod Clutch Secondary	129	819 13 13-12	Washer 13/32 x 13/16 x 12 Ga.
45	532 12 47-88	Spring Retainer 1" Zinc/cad	130	874 78 06-16	Bolt, Fin Hex 3/8-16 UNC x 1 Gr. 5
53	532 13 08-40	Asm Brake	131	872 14 06-08	Bolt, Rdhd Sqnk 3/8-16 x 1
54	532 13 39-43	Washer Hardened	--	532 13 07-94	Mandrel Asm Service (Includes Key Nos. 8-10, 12-15, 31 and 33)
55	532 13 38-40	Arm Idler	--	532 14 28-20	Mower Deck Complete (Std. Deck - order separately mulcher plate components key nos. 96-101)
56	532 12 20-52	Spacer Retainer Pm Mower			
67	532 10 69-33	Knob Rd 1/2-13 Plstc Thds Blk			
68	532 14 42-00	V-Belt Mower			
69	876 02 03-12	Pin, Cotter 3/32 x 3/4			
71	532 14 24-27	Rod Clutch Primary 38/42			

**NOTE:** All component dimensions given in U.S. inches  
1 inch = 25.4 mm



# REPAIR PARTS

TRACTOR - MODEL NO. LTH120 (954140003A), PRODUCT NO. 954 1400-03

## MOWER LIFT

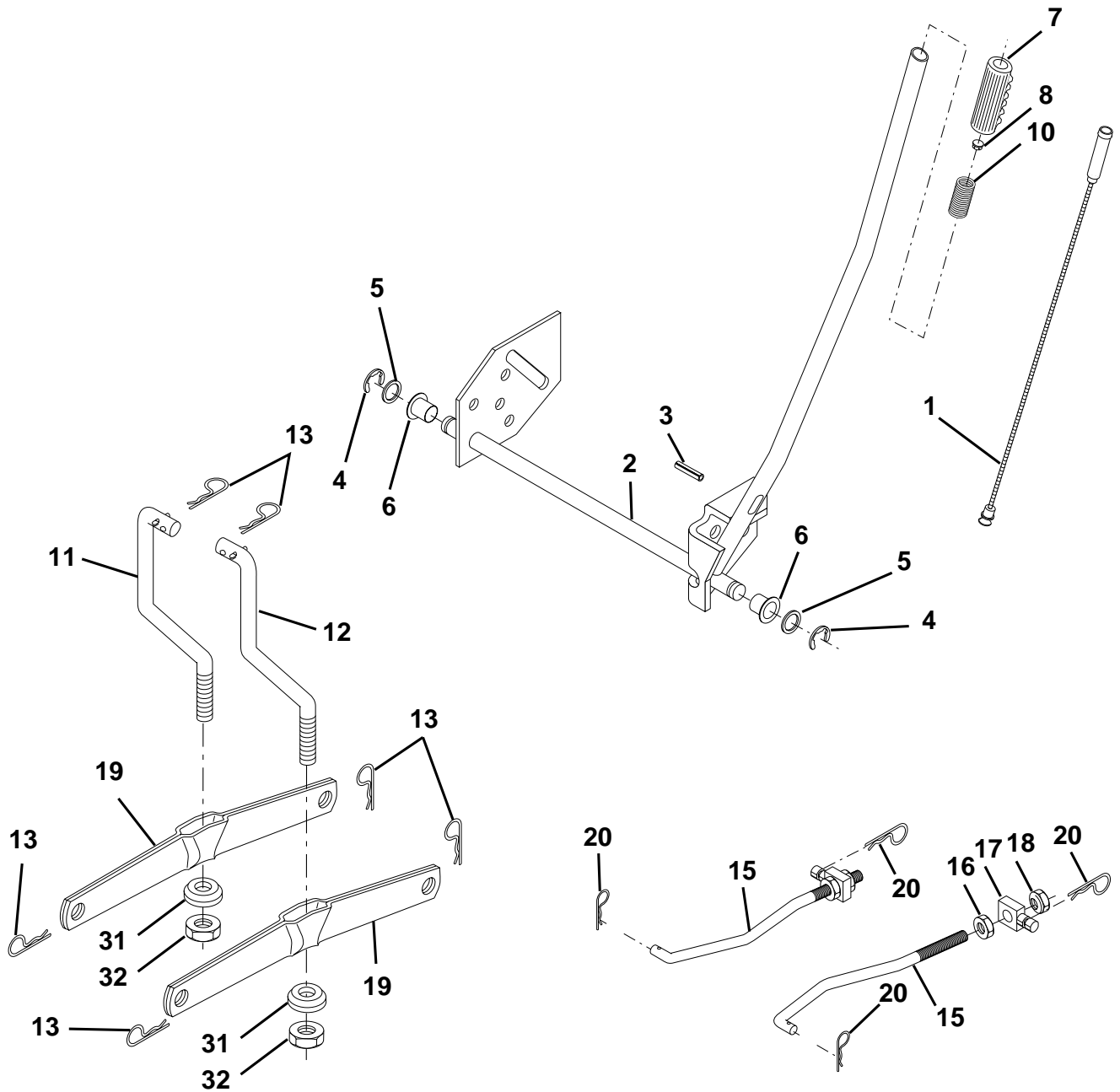

# REPAIR PARTS

TRACTOR - MODEL NO. LTH120 (954140003A), PRODUCT NO. 954 1400-03

## MOWER LIFT

KEY NO.	PART NO.	DESCRIPTION
1	532 13 69-73	Wire Asm Inner W/plunger 17 32
2	532 14 51-17	Shaft Asm Lift
3	532 10 57-67	Pin Groove
4	812 00 00-02	E Ring #5133-62
5	819 21 16-21	Washer PLTD 21/32 X 1 X 21ga
6	532 12 01-83	Bearing Nylon Blk 629 Id
7	532 10 94-13	Grip Handle Bicycle
8	532 12 45-26	Button Plunger Black
10	532 12 25-12	Spring Cprsn 3 750 Oiled
11	532 13 98-65	Link Lift LH
12	532 13 98-66	Link Lift RH
13	532 12 46-70	Retainer Spring
15	532 12 72-18	Link Front
16	873 35 08-00	Nut Jam Hex 1/2-13 Unc
17	532 13 01-71	Trunnion Blk Zinc
18	873 80 08-00	Nut Lock W/wsh 1/2-13unc
19	532 13 98-68	Arm Suspension Rear
20	532 12 46-60	Spring, Retainer
31	532 14 03-02	Bearing Pvt. Lift Spherical
32	873 54 06-00	Nut Crownlock 3/8-24

**NOTE:** All component dimensions given in U.S. inches  
1 inch = 25.4 mm

# REPAIR PARTS

TRACTOR - MODEL NO. LTH120 (954140003A), PRODUCT NO. 954 1400-03  
HYDRO TRANSAXLE - MODEL NUMBER 310-500

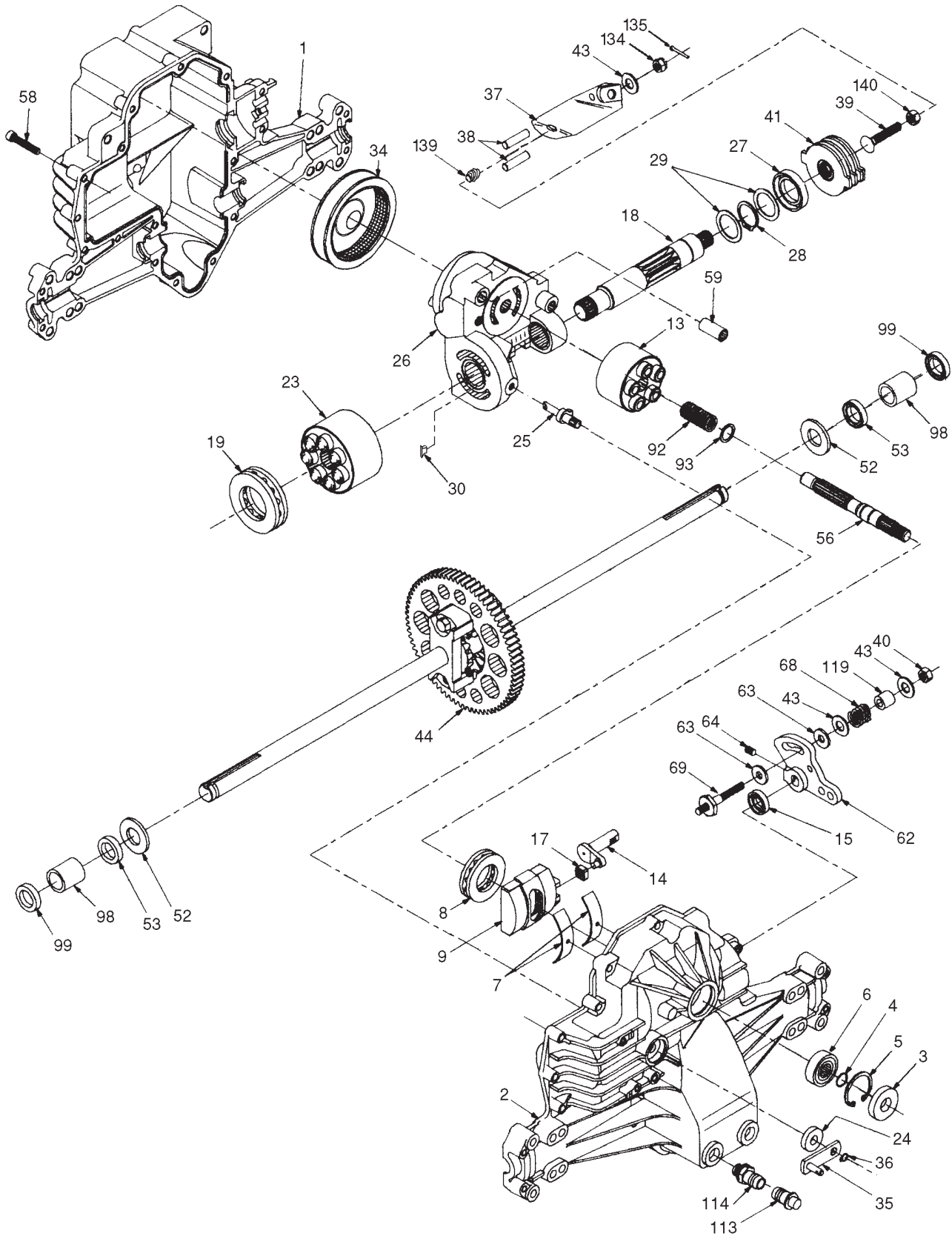

# REPAIR PARTS

TRACTOR - MODEL NO. LTH120 (954140003A), PRODUCT NO. 954 1400-03

## HYDRO TRANSAXLE - MODEL NUMBER 310-500

KEY PART NO. NO.	DESCRIPTION	KEY PART NO. NO.	DESCRIPTION		
1	532 14 29-86	Housing, Lower	40	532 15 07-78	Locknut, Hex 5/16-24 UNJC
2	532 14 29-87	Assembly, Upper Housing	41	532 14 29-58	Brake Rotor/Stator Kit
3	532 14 29-32	Seal, Lip	43	532 14 28-84	Washer 7/16 x 7/8 x .060
4	532 14 29-28	Ring, Wire Retaining	44	532 14 29-90	Differential Assembly
5	532 14 29-33	Ring, Retaining	52	532 14 29-91	Washer 3/4 x 1.5 x .13
6	532 14 29-34	Bearing, Shaft Ball	53	532 14 29-61	Seal .75 x 1.25 x .250
7	532 14 29-35	Bearing, Cradle	56	532 14 29-63	Shaft, Input
8	532 15 07-71	Bearing, Thrust 30 x 52 x 13	58	532 14 29-64	Bolt 1/4-20 x 1.38
9	532 14 29-37	Swashplate, Variable	59	532 14 29-65	Pin .5 OD x .43 ID x .750
13	532 14 29-38	Block, Cylinder Assembly	62	532 14 29-66	Arm, Control
14	532 14 29-39	Arm, Trunnion	63	532 14 29-67	Puck, Dampener
15	532 14 29-40	Seal, Lip	64	532 14 29-20	Set Screw
17	532 14 29-41	Guide, Slot	68	532 14 29-69	Spring
18	532 15 07-72	Shaft, Motor	69	532 14 46-10	Stud 5/16-24
19	532 15 07-73	Bearing, Thrust 42 x 68 x 16	92	532 14 29-77	Spring, Block
23	532 14 29-44	Block, Cylinder Assembly	93	532 14 29-78	Washer, Block Thrust
24	532 14 29-45	Seal, Lip 10 x 25 x 7	98	532 14 29-93	Sleeve Bearing
25	532 14 29-46	Actuator, Bypass	99	532 14 29-76	Seal, Wiper
26	532 15 07-74	Center Section Assembly Kit	113	532 14 29-17	Cap, Vent Assembly
27	532 14 29-48	Seal, Lip 26 x 42 x 8	114	532 14 29-18	Fitting, O-Ring Assembly
28	532 14 29-49	Ring, Retaining	119	532 14 29-80	Spacer
29	532 14 29-50	Washer 26 x 35 x 1	134	532 14 46-07	Nut, Castle 5/16-24
30	532 15 07-87	Nut, Jam	135	532 14 46-08	Pin, Cotter
34	532 14 29-51	Oil Filter Element	139	532 15 07-75	Spring, Compression
35	532 14 29-52	Arm, Bypass	140	532 15 07-76	Nut, Hex 5/16-24
36	532 14 29-53	Ring, Retaining			
37	532 14 29-54	Arm, Actuating			
38	532 14 29-55	Pin, Actuating			
39	532 15 07-77	Bolt 5/16-24 x 1-3/4			

**NOTE:** All component dimensions given in U.S. inches  
1 inch = 25.4 mm