

YTH 150

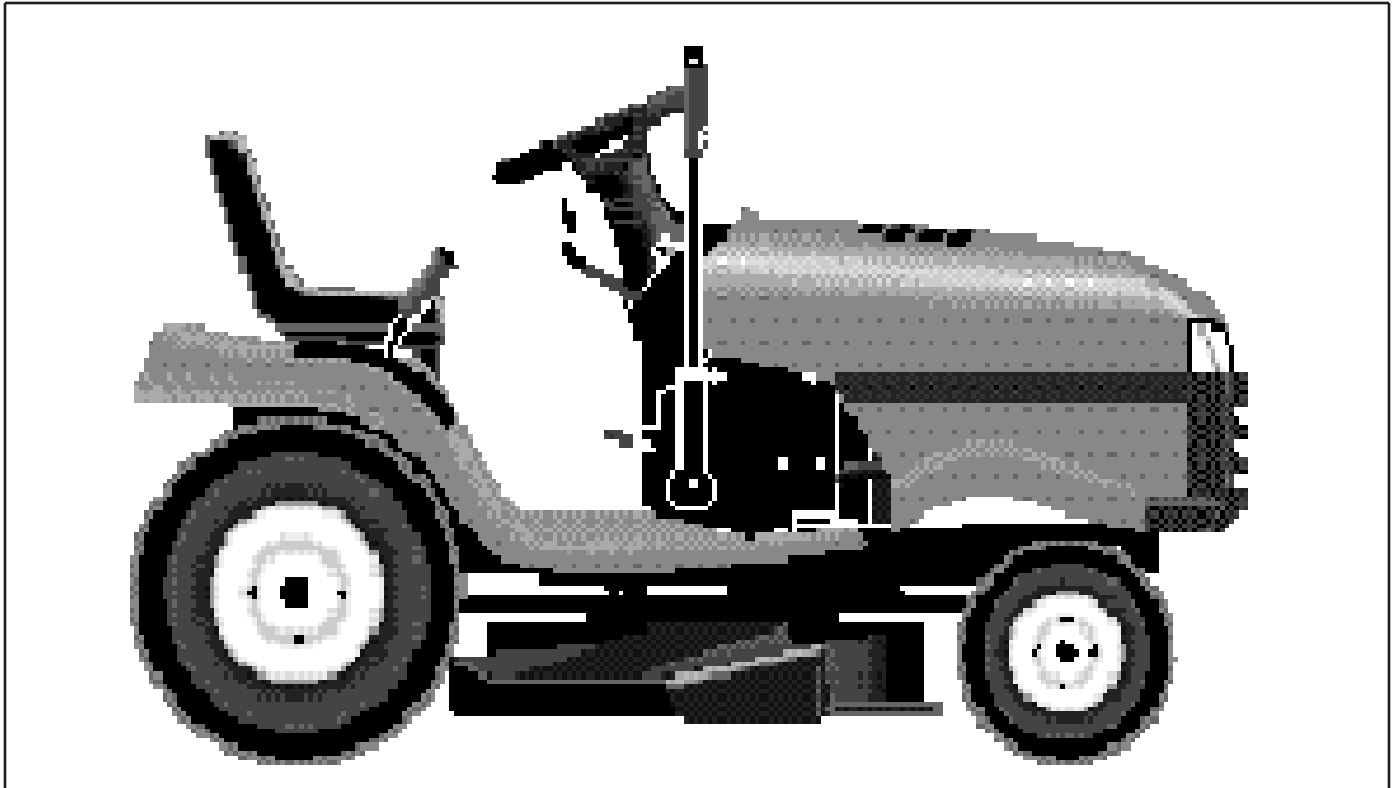

1.1997
Spare Parts

954 14 00-07A

REPAIR PARTS

TRACTOR - MODEL NO. YTH150 (954140007A), PRODUCT NO. 954 14 00-07

SCHEMATIC

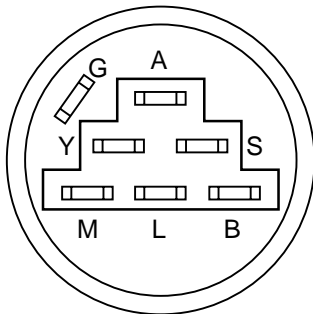
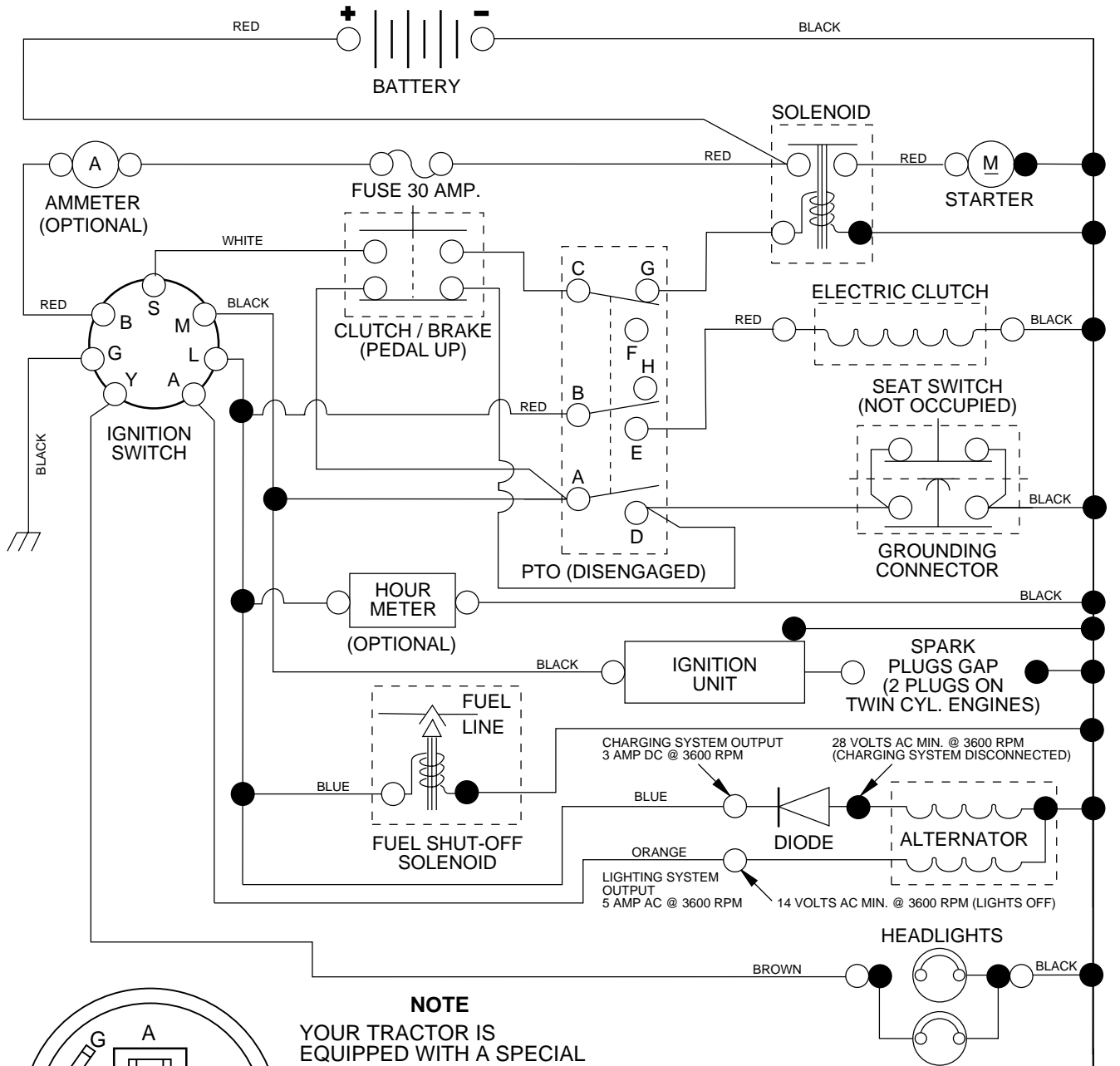

IGNITION SWITCH

POSITION	CIRCUIT	"MAKE"
OFF	G + M + L	NONE
RUN/LIGHT	B + L	A + Y
RUN	B + L	NONE
START	B + L + S	NONE

NOTE

YOUR TRACTOR IS EQUIPPED WITH A SPECIAL ALTERNATOR SYSTEM. THE LIGHTS ARE NOT CONNECTED TO THE BATTERY, BUT HAVE THEIR OWN ELECTRICAL SOURCE. BECAUSE OF THIS, THE BRIGHTNESS OF THE LIGHTS WILL CHANGE WITH ENGINE SPEED. AT IDLE THE LIGHTS WILL DIM. AS THE ENGINE IS SPEEDED UP, THE LIGHTS WILL BECOME THEIR BRIGHTEST.

PTO SWITCH

POSITION	CIRCUIT
OFF	C + G, B + H
ON	C + F, B + E, A + D

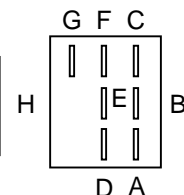

WIRING INSULATED CLIPS

NOTE: IF WIRING INSULATED CLIPS WERE REMOVED FOR SERVICING OF UNIT, THEY SHOULD BE REPLACED TO PROPERLY SECURE YOUR WIRING.

REPAIR PARTS

TRACTOR - MODEL NO. YTH150 (954140007A), PRODUCT NO. 954 14 00-07

ELECTRICAL

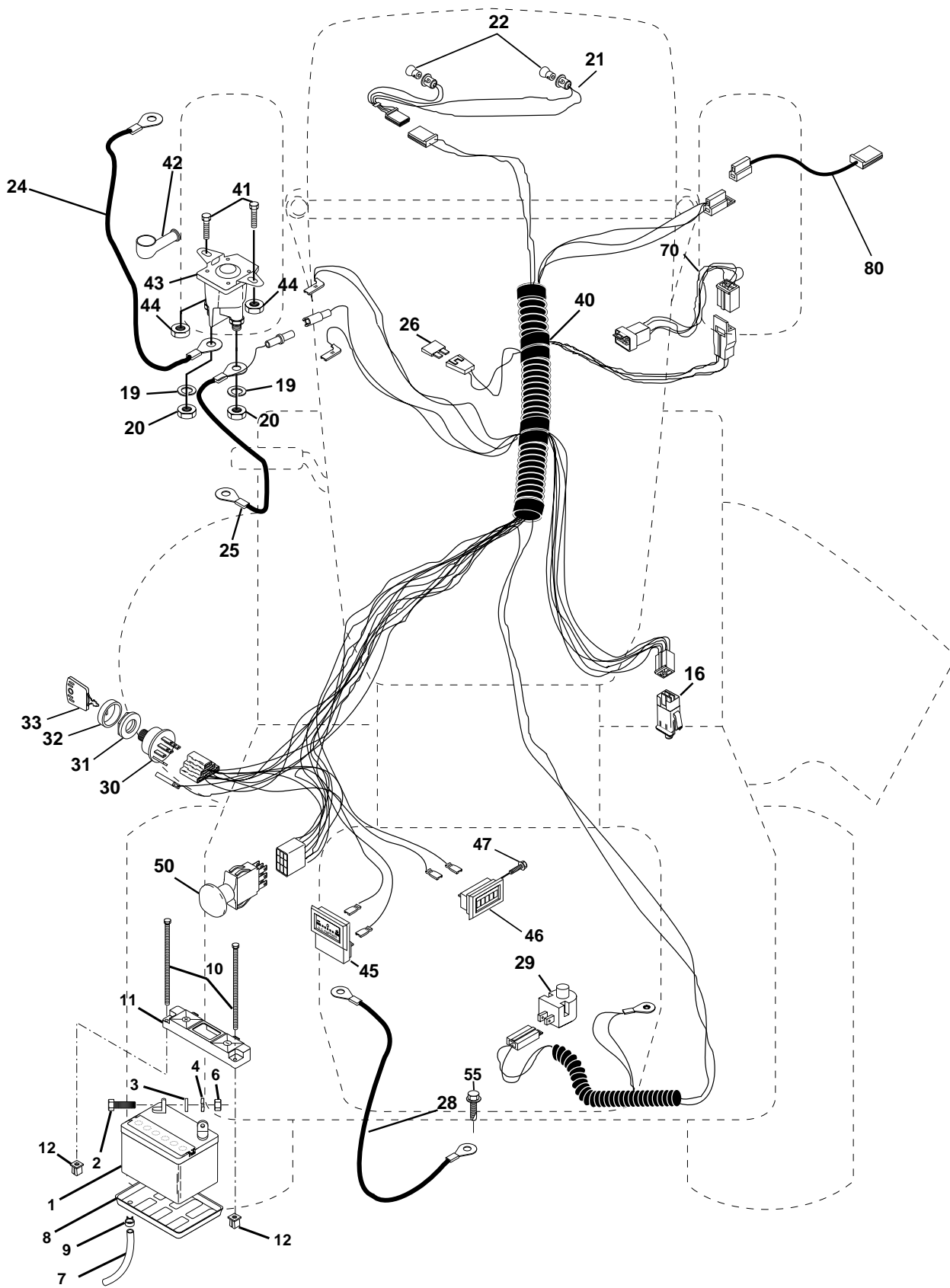

REPAIR PARTS

TRACTOR - MODEL NO. YTH150 (954140007A), PRODUCT NO. 954 14 00-07

ELECTRICAL

KEY NO.	PART NO.	DESCRIPTION
1	532 14 61-39	Battery 12 Volt 25 AMP
2	874 76 04-12	Bolt Hex Hd 1/4-20unc X 3/4
3	819 09 10-16	Washer 9/32 X 5/8 X 16 Ga.
4	810 04 04-00	Washer Lock Hvy Helical 1/4
6	873 22 04-00	Nut Fin Hex 1/4-20 Unc
7	532 00 76-97	Tube Plastic 46"
8	532 12 48-86	Tray Battery 7.80 x 5.25 Blk
9	532 10 95-96	Clamp Hose Olive
10	532 14 52-11	Bolt Btr Frt 1/2-20 x 7.5 Zinc
11	532 15 01-09	Holddown Battery Front Mount
12	532 14 57-69	Nut Push Nylon 1/4" Battery Frt
16	532 15 36-64	Switch Interlock Push-In
19	810 09 04-00	Washer Lock 1/4
20	873 35 04-00	Nut Jam Hex 1/4-20 Unc
21	532 13 68-50	Harness Asm Light W/4152j
22	532 00 41-52	Bulb Light #1156
24	532 12 47-80	Cable Battery 6 Ga 11" red
25	532 14 61-48	Cable Battery 6 Ga 44" red w/16 wire
26	532 10 88-24	Fuse 30 AMP Auto Green
28	532 14 54-91	Cable Ground 6 Ga 21" black
29	532 12 13-05	Switch Plunger Nc Gray
30	532 14 03-01	Switch Ign 4 pos w/lights
31	532 12 42-11	Nut Ignition
32	532 14 12-26	Cover Sw Ignition
33	532 12 21-47	Key Ign Modelled Generic
40	532 15 64-43	Harness Ign.
41	871 11 04-08	Bolt Blk Fin Hex 1/4 - 20 x 1/2
42	532 13 15-63	Cover Terminal Red
43	532 14 56-73	Solenoid
44	873 64 04-00	Nut Keps Hex 1/4-20 Unc
45	532 12 14-33	Ammeter Rectangular 6 Amp
46	532 11 09-40	Meter Hour
47	817 01 10-08	Screw 10-24 x 1/2 Black
50	532 15 49-59	Switch PTO 3PDT Black Delta 96
55	817 49 05-08	Screw Thdrol 5/16-18 x 1/2 Tyt
70	532 14 26-21	Harness, Eng Kohl Cmd-L Dual
80	532 14 66-85	Harness Clutch Evx

NOTE: All component dimensions given in U.S. inches.
1 inch = 25.4 mm.

REPAIR PARTS

TRACTOR - MODEL NO. YTH150 (954140007A), PRODUCT NO. 954 14 00-07

CHASSIS AND ENCLOSURES

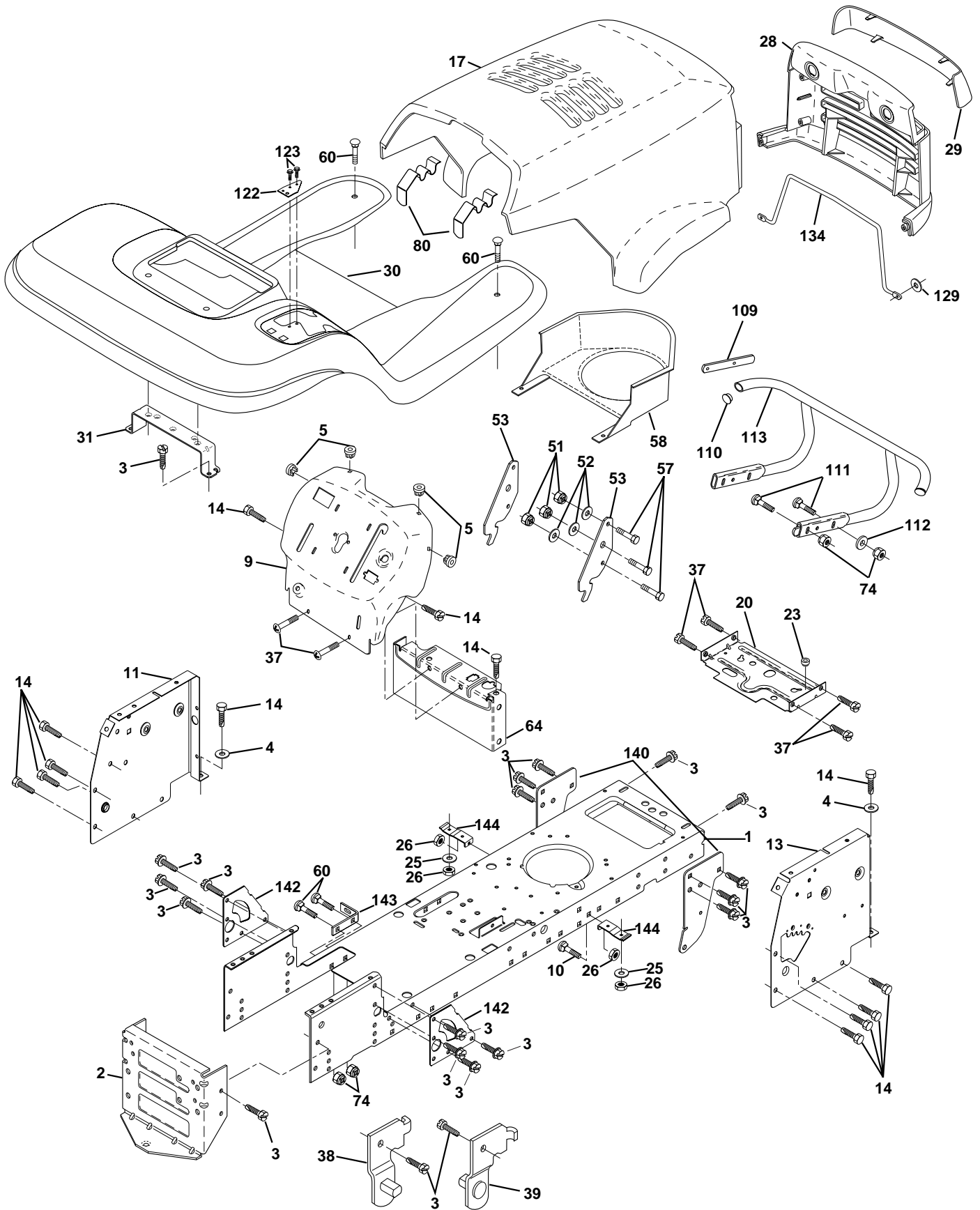

REPAIR PARTS

TRACTOR - MODEL NO. YTH150 (954140007A), PRODUCT NO. 954 14 00-07

CHASSIS AND ENCLOSURES

KEY NO.	PART NO.	DESCRIPTION
1	532 15 38-71	Chassis Weldment
2	532 14 03-56	Drawbar, Stretch
3	817 49 06-12	Screw Thdrol 3/8-16x3/4 Ty-tt
4	819 13 12-16	Washer 13/32 x 3/4 x 16 Ga.
5	532 15 52-72	Bumper Hood/Dash
9	532 15 64-90	Dash Slkscr.Plm.E.A.Hm.Nc.Sym
10	872 14 06-08	Bolt Carriage 3/8-16 x 1
11	532 15 59-27	Panel Dash Lh
13	532 15 39-13	Panel Dash Rh
14	817 49 06-08	Screw Thdrol 3/8-16x1/2 Ty-tt
17	532 15 60-51	Hood LT/PL Husqvarna
20	532 15 64-37	Plate Mtg Battery Fuel Tank Fr
23	532 12 40-28	Bushing
25	819 13 13-12	Washer 13/32 X 13/16 X 12 Ga
26	873 80 06-00	Nut Lock Hex W/Ins 3/8-16 Unc
28	532 14 97-76	Grille LT/PL Husqvarna
29	532 14 97-77	Lens LT/PL Husqvarna
30	532 15 64-89	Fender Footrest STLT Pnt
31	532 13 99-76	Bracket Support Fender
37	817 49 05-08	Screw Thdrol 6/16-18 x 1/2 TYT
38	532 13 98-86	Bracket, Asm. Pivot, L.H., Mower Rear
39	532 13 98-87	Bracket, Asm. Pivot, R.H., Mower Rear
51	873 80 04-00	Nut Lock Hex W/Ins 1/4-20
52	819 09 14-16	Washer 9/32 x 7/8 x 16 Ga.
53	532 15 00-67	Bracket Pnt. Pick off LT/PL Husqvarna
57	874 78 04-12	Bolt Hex 1/4-20 x 3/4
58	532 15 01-27	Air Duct Engine P/L
60	872 14 06-06	Bolt Rdhd Sqnk 3/8-16unc x 3/4
64	532 15 47-98	Dash Lower STLT
74	873 68 06-00	Nut Crownlock 3/8-16 UNC
80	532 15 58-54	Latch Hood Plm Husqvarna
109	532 14 14-61	Bracket Extension Bumper
110	532 14 36-79	Plug Plastic
111	872 14 06-12	Bolt Rdhd 3/8-16unc x 1-1/2
112	819 13 13-16	Washer 13/32 x 13/16 x 16 Ga.
113	532 15 03-00	Bumper Asm.
129	819 09 10-16	Washer 9/32 x 5/8 x 16 Ga.
134	532 15 01-32	Rod Support Hood LT/PL Husq.
140	532 15 05-56	Bracket Chassis Front 7 Ga.
142	532 15 60-95	Plate Reinforcement STLT
143	532 15 49-66	Bracket Swaybar Chassis
144	532 15 42-07	Bracket Pnt Footrest STLT
146	532 15 43-34	Screw Torx Hd Thd 5/16-18 UN-2A

NOTE: All component dimensions given in U.S. inches
1 inch = 25.4 mm

REPAIR PARTS

TRACTOR - MODEL NO. YTH150 (954140007A), PRODUCT NO. 954 14 00-07

DRIVE

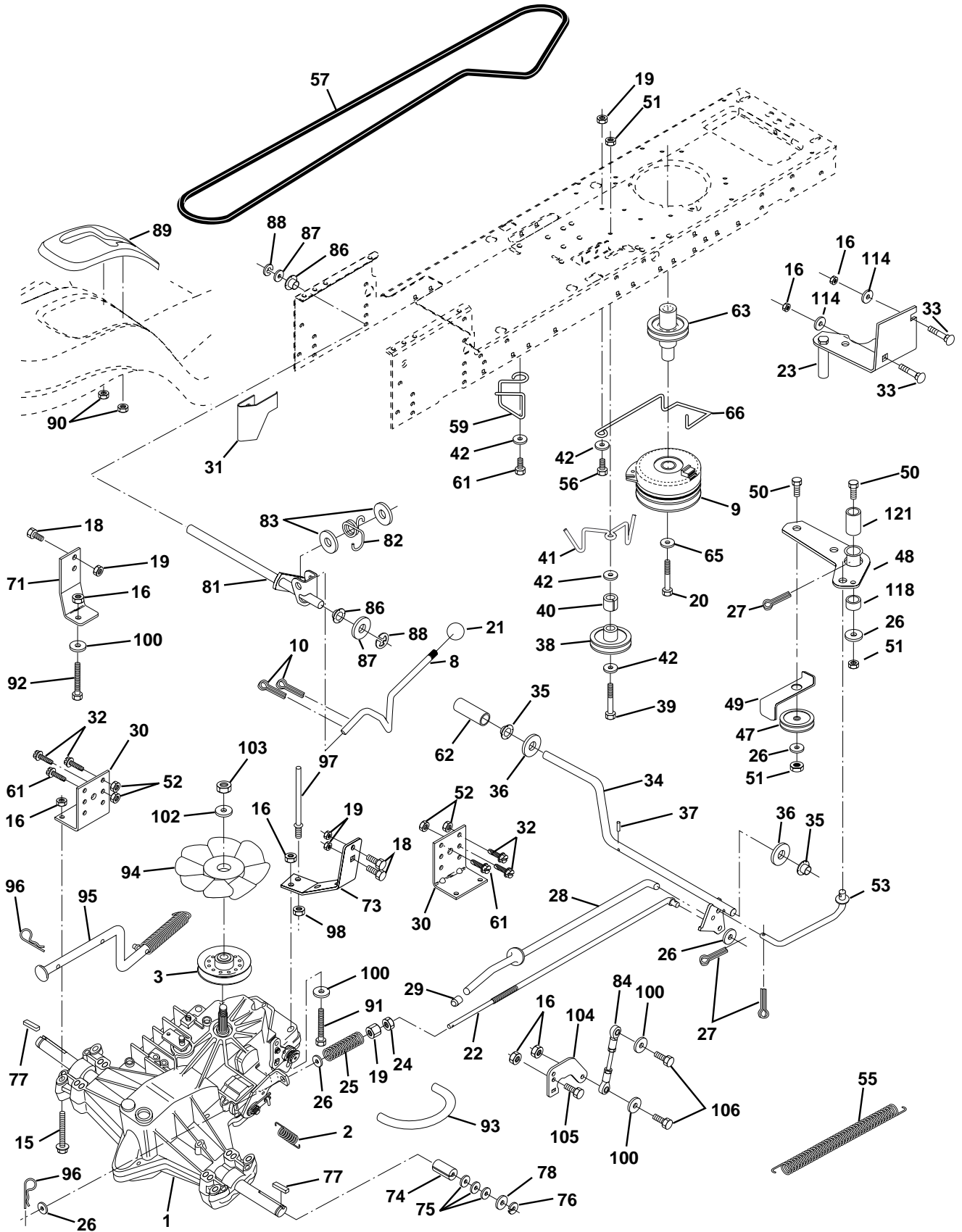

REPAIR PARTS

TRACTOR - MODEL NO. YTH150 (954140007A), PRODUCT NO. 954 14 00-07

DRIVE

KEY PART NO.	NO.	DESCRIPTION	KEY PART NO.	NO.	DESCRIPTION
1	5 32 15-0071	Transaxle w/cas Hydro 310-0650	57	532 14 02-94	V-Belt, Ground Drive
2	532 14 24-31	Spring, Return, Brake	59	532 14 03-12	Keeper, Center Span
3	532 14 39-95	Pulley, Transaxle Hydro 750 LT	61	817 49 06-12	Screw Thdrol. 3/8-16 x 3/4 Ty. TT
8	532 15 47-92	Rod Shift Hydro LT	62	532 12 35-33	Cover, Pedal Premium
9	532 14 50-28	Clutch Electric	63	532 14 58-68	Pulley, Engine
10	876 02 04-16	Pin Cotter 1/8 x 1 CAD	65	810 04 07-00	Washer Lock Hvy HLCL Spr 7/16
15	874 49 05-44	Bolt Hex 5/16-18 Unc Flghd	66	532 15 47-78	Keeper Belt Engine
16	873 80 05-00	Nut Lock Hex W/Ins. 5/16-18 Unc P	73	532 15 63-47	Strap Torque Rh Hydro
18	874 78 06-16	Bolt Fin Hex 3/8-16 Unc x 1 Gr.5	71	532 14 01-58	Strap Torque Lh Hydro
19	873 80 06-00	Nut Lock Hex W/Ins 3/8-16 Unc	74	532 12 11-99	Spacer, Split
20	532 15 02-80	Bolt, Hex 7/16-20 x 4-1/4 Ga. 5	75	532 12 17-49	Washer 25/32 x 1-1/4 x 16 Ga.
21	532 14 08-45	Knob Deluxe 1/2-13 UNC BLK/BLK	76	812 00 00-01	E-Ring
22	532 14 56-27	Rod, Brake Hydro	77	532 12 35-83	Key, Square
23	532 15 49-78	Bracket Asm Mtg CL	78	532 12 17-48	Washer 25/32 x 1-5/8 x 16 Ga
24	873 35 06-00	Nut Hex Jam 3/8-16 UNC	81	532 15 60-46	Shaft Asm. Cross Hydro 20" Tires
25	532 10 68-88	Spring, Brake Rod	82	532 12 37-82	Spring Torsion T/A
26	819 13 13-16	Washer	83	819 17 12-16	Washer 17/32 x 3/4 x 16 Ga.
27	876 02 04-12	Pin Cotter 1/8 x 3/4 CAD.	84	532 14 05-48	Rod, Tie Hydro 20" Tires SPH Ball 4.75
28	532 14 52-04	Rod, Parking Brake	86	532 07 12-08	Bushing Rod Strig. 629/632 ID
29	532 07 16-73	Cap, Parking Brake	87	819 21 20-16	Washer 21/32 x 1-1/4 x 16 Ga.
30	532 13 08-07	Bracket, Transaxle	88	812 00 00-08	Ring Klip #5304-62
31	532 12 72-75	Keeper Belt Lh	89	532 15 48-82	Console, Hydro STLT
32	874 76 05-12	Bolt Hex Hd 5/16-18 Unc x 3/4	90	532 12 43-46	Nut Self-Thd Wsh-Hd 1/4 Zinc
33	872 14 05-06	Bolt Carriage 5/16-18 UNC x 3/4	91	874 78 05-36	Bolt Fin Hex 5/16-18 x 2-1/4
34	532 15 50-71	Shaft, Foot Pedal	92	874 78 05-24	Bolt Fin Hex 5/16-18 Unc x 1-1/2
35	532 12 01-83	Bearing, Nylon	93	532 14 25-64	Line Fuel Hydro 4"
36	819 21 16-16	Washer	94	532 14 04-62	Fan, Hydro 7"
37	532 12 49-63	Pin, Roll	95	532 14 46-43	Control Asm. Bypass Hydro
38	532 12 36-74	Pulley, Idler, Flat	96	532 12 47-88	Retainer Spring 1" Zinc/Cad
39	874 76 06-44	Bolt	97	532 14 04-69	Keeper Belt Rh Hydro 0750.18/20"
40	532 12 49-65	Spacer Split	98	873 51 06-00	Nut Keps Hex 3/8-16 Unc
41	532 15 47-77	Keeper, Belt Idler	100	819 11 12-16	Washer 11/32 x 3/4 x 16 Ga.
42	819 13 13-12	Washer 13/32 x 13/16 x 12 Ga	102	532 14 13-22	Washer Belleville .501D x 1.50D
47	532 12 77-83	Pulley, Idler, V-Groove Plastic	103	873 94 08-00	Nut Hex Jam Toplock 1/4-20 Unf
48	532 15 46-04	Bellcrank Assembly	104	532 14 01-56	Arm, Control Hydro
49	532 12 32-05	Retainer, Belt Style Spring	105	871 07 05-16	Screw Cap Hex 5/16 x 18 x 1
50	874 76 06-24	Bolt	106	874 78 05-20	Bolt Fin Hex 5/16-18 Unc x 1-1/4
51	873 68 06-00	Nut	114	819 11 12-14	Washer 11/32 x 3/4 x 14 Ga.
52	873 68 05-00	Nut Crown Lock 5/16-18	118	532 15 47-74	Spacer Bellcrank
53	532 10 57-10	Link, Clutch	121	532 15 44-19	Nyliner Clutching STL
55	532 10 57-09	Spring, Return, Clutch			
56	874 76 06-20	Bolt, Fin Hex 3/8-16 UNC x 1 1/4			

NOTE: All component dimensions given in U.S. inches
1 inch = 25.4 mm

REPAIR PARTS

TRACTOR - MODEL NO. YTH150 (954140007A), PRODUCT NO. 954 14 00-07

STEERING ASSEMBLY

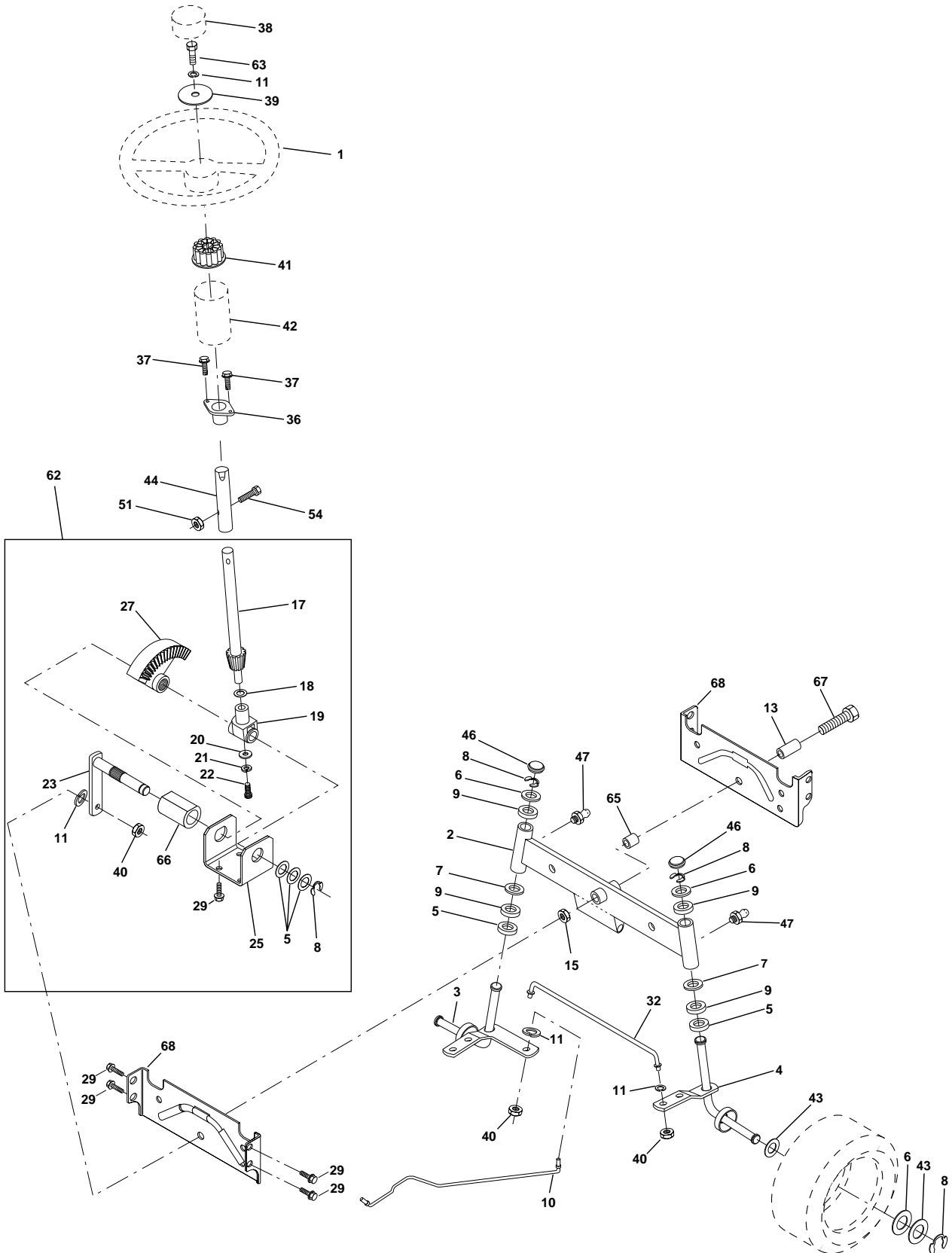

REPAIR PARTS

TRACTOR - MODEL NO. YTH150 (954140007A), PRODUCT NO. 954 14 00-07

STEERING ASSEMBLY

KEY NO.	PART NO.	DESCRIPTION
1	532 12 44-15	Wheel Steering
2	532 13 70-94	Axle Front Casting Machined
3	532 15 49-20	Spindle Asm LH
4	532 15 49-21	Spindle Asm RH
5	532 12 49-31	Bearing Race Thrust Harden
6	532 12 17-48	Washer 25/32 X 1-5/8 X 16 Ga
7	819 27 20-16	Washer 27/32 X 1-1/4 X 16 Ga
8	812 00 00-29	Ring Klip #t5304-75
9	532 12 49-37	Bearing Col Strg Blk
10	532 15 44-32	Link Drag Extended Cast
11	810 04 06-00	Washer Lock Hvy Hlcl Spr 3/8
13	532 15 47-79	Bearing Axle STLT/GT
15	873 90 10-00	Nut Lock Flange 5/8-11 Unc
17	532 15 65-46	Shaft Asm Strg
18	532 05 70-79	Washer Thrust 515x 750x 033
19	532 12 40-35	Support Shaft
20	532 12 66-84	Washer Shim 1/4 X 5/8 X 062
21	810 04 04-00	Washer Lock Hvy Helical 1/4
22	871 10 04-10	Screw Cap Sckt Hd Phos & Oil
23	532 12 75-01	Shaft Asm Pittman
25	532 15 44-06	Bracket Steering
27	532 13 68-74	Gear Sector
29	817 49 06-12	Screw Thdrol 3/8-16x3/4 Ty-tt
32	532 13 73-47	Rod Asm Tie Ball Adj. VGT
36	532 15 50-99	Bushing Strg
37	532 15 29-27	Screw
38	532 12 44-16	Insert Cap Strg Wh Au
39	819 13 38-08	Washer 13/32 X 2-3/8 X 8 Ga
40	532 12 47-01	Lock nut
41	532 10 07-11	Adaptor Wheel Strg
42	532 15 50-92	Boot Steering Shaft
43	532 12 17-49	Washer 25/32 X 1 1/4 X 16 Ga
44	532 15 37-20	Extension Steering Shaft LR/LT
46	532 12 12-32	Cap Spindle Fr Top Blk
47	532 12 48-36	Fitting Grease
51	873 80 05-00	Nut Lock Hex w/Ins 5/16-18
54	874 78 05-20	Bolt Fin Hex 5/16-18 Unc x 1-1/4
62	532 15 65-94	Kit, Steering Assembly Svc
63	874 78 06-16	Bolt Fin Hex 3/8-16unc x 1 Gr. 5
65	532 15 47-80	Spacer Axle
66	532 15 44-04	Bearing Arm Pittman
67	874 78 10-44	Bolt, Fin Hex 5/8-11 UNC x 2-3/4
68	532 15 44-29	Brace, Axle

NOTE: All component dimensions given in U.S. inches.
1 inch = 25.4 mm.

REPAIR PARTS

TRACTOR - MODEL NO. YTH150 (954140007A), PRODUCT NO. 954 14 00-07

SEAT ASSEMBLY

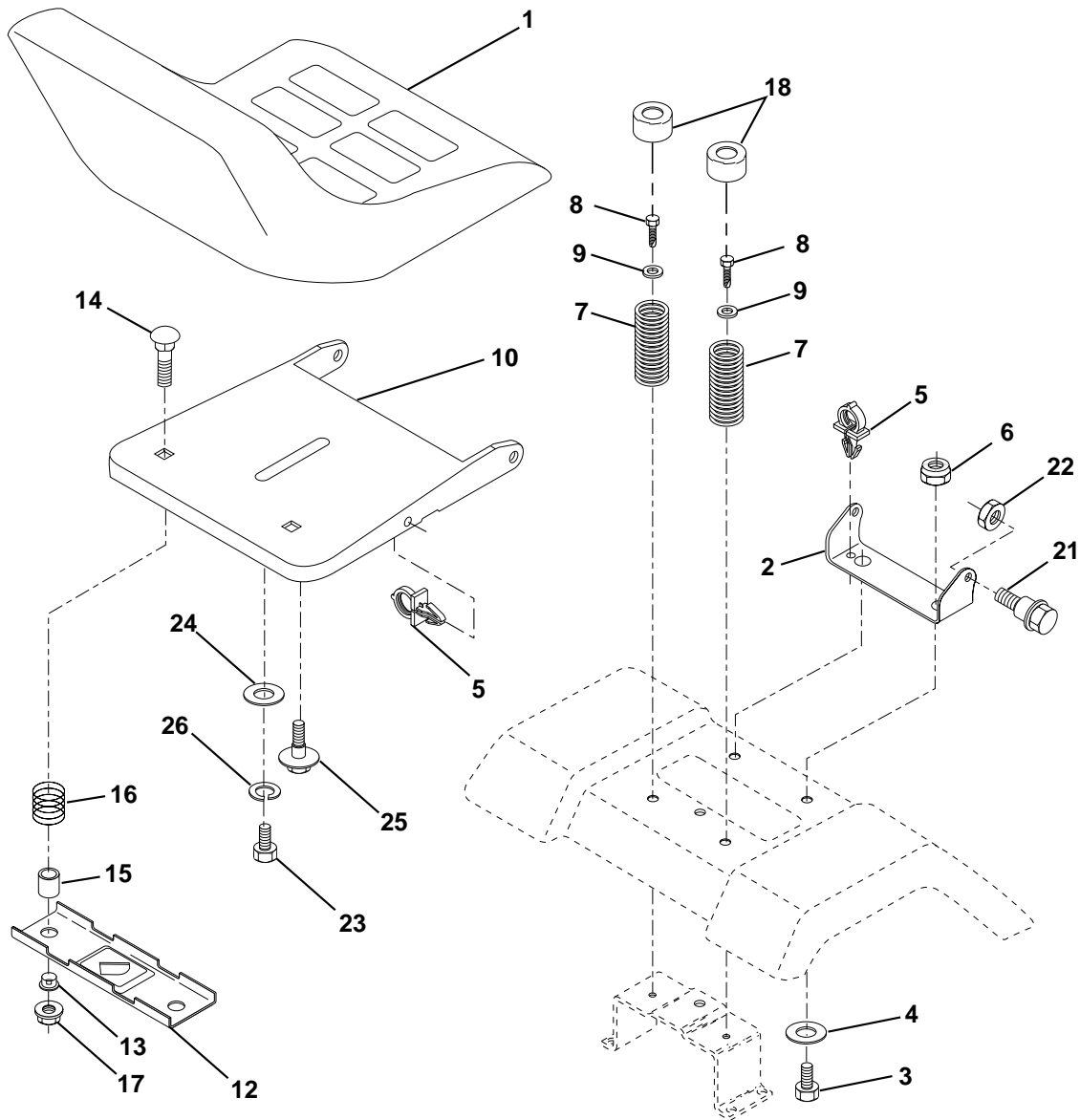

KEY PART NO. NO.

DESCRIPTION

1	532 14 08-39	Seat
2	532 14 05-51	Bracket Pivot Seat 8 720
3	874 76 06-16	Bolt Fin Hex 3/8-16unc X 1
4	819 13 16-10	Washer 13/32 X 1 X 10 Ga
5	532 14 50-06	Clip Push-In
6	873 80 06-00	Nut Hex w/Ins. 3/8-16 Unc
7	532 12 41-81	Spring Seat Cprsn 2 250 Blk Zi
8	817 49 06-16	Screw Thdrol 3/8-16 X 1 Ty-tt
9	819 13 16-14	Washer 13/32 X 1 X 14 Ga.
10	532 15 59-25	Pan Seat
12	532 12 12-46	Bracket Mounting Switch
13	532 12 12-48	Bushing Snap Blk Nyl 50 Id
14	872 05 04-11	Bolt Rdhd Sqnk 1/4-20x1-3/8

KEY PART NO. NO.

DESCRIPTION

15	532 13 43-00	Spacer Split 28x 96 Yel Zinc
16	532 12 12-50	Spring Cprsn 1 27 Blk Pnt
17	532 12 39-76	Nut Lock 1/4 Lge Flg Gr 5 Zinc
18	532 12 42-38	Cap Spring Seat
21	532 15 32-36	Bolt Shoulder 5/16-18 Unc
22	873 80 05-00	Nut Hex Lock W/Ins 5/16-18
23	874 78 08-14	Bolt, Hex Head, Fin 1/2-13 x 7/8 Grade 5
24	819 17 19-12	Washer 17/32 X 1-3/16 X 12 Ga.
25	532 12 70-18	Bolt Shoulder 5/16-18 X 62
26	810 04 08-00	Washer Lock

NOTE: All component dimensions given in U.S. inches.
1 inch = 25.4 mm

REPAIR PARTS

TRACTOR - MODEL NO. YTH150 (954140007A), PRODUCT NO. 954 14 00-07

DECALS

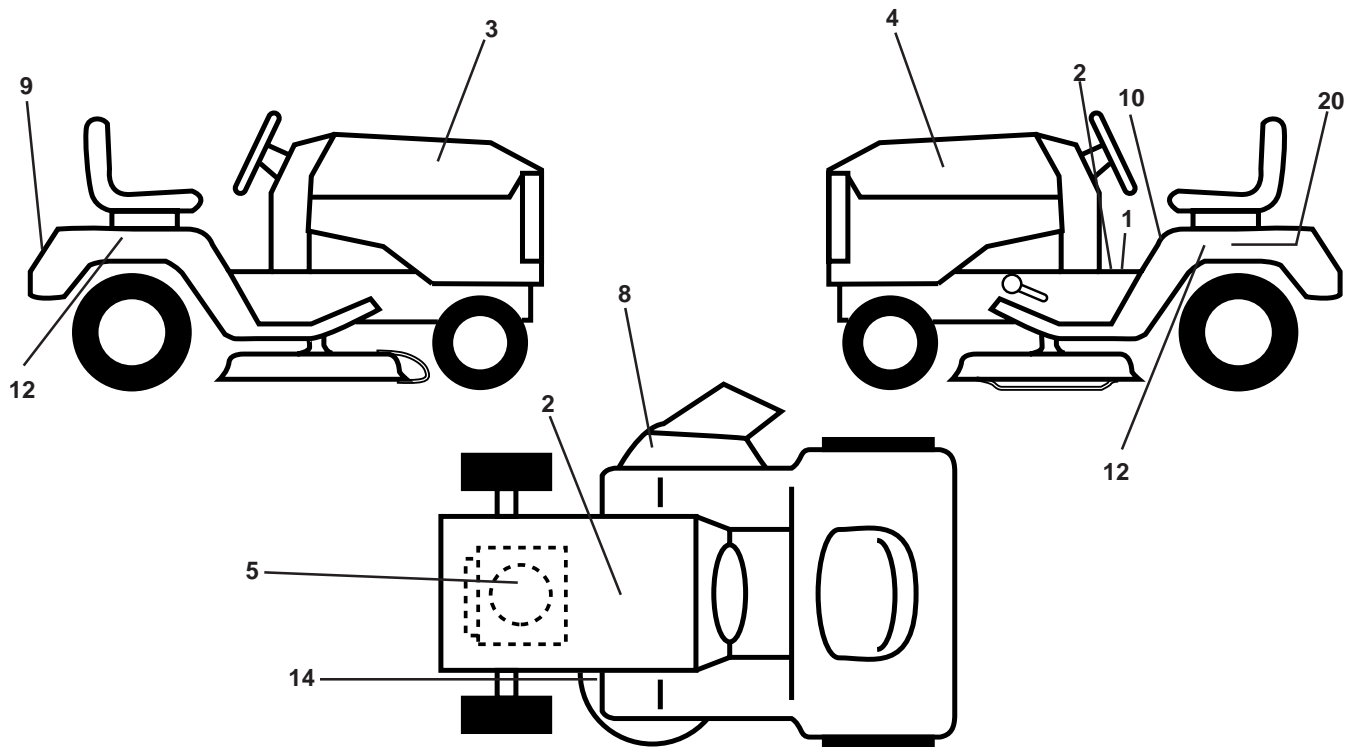

KEY NO.	PART NO.	DESCRIPTION
1	532 15 70-32	Decal Oper. Step Thru E/F
2	532 14 64-51	Decal Battery
3	532 15 07-30	Decal Hood LH
4	532 15 07-29	Decal Hood RH
5	532 15 12-44	Decal HP Engine
8	532 13 72-59	Decal Warning Multi-Languages
9	532 15 06-17	Decal Fender Husq
10	532 15 71-40	Decal Fender Danger E/F
12	532 15 70-07	Decal Fender Auto Husq Radius
14	532 13 68-32	Decal V-Belt Schematic
--	532 15 45-15	Pad Footrest LH STLT

KEY NO.	PART NO.	DESCRIPTION
--	532 14 23-41	Decal Drawbar Cntrl Mvt Hyd LT
--	532 15 45-16	Pad Footrest RH STLT
--	532 13 83-11	Decal Handle Lft Height Adjust
--	532 15 72-25	Manual Owner's (English)
--	532 15 72-26	Manual Owner's (French)

Available accessories not included with tractor:

--	MK420	Mulcher Kit with Blades
--	C40	Grass Catcher
--	LSB42	42" Snow Blower
--	LC05	Wheel Wts. (Pair)
--	LC06	Tire Chains 20 x 10 x 8
--	LBD48	48" Snow Blade

WHEELS & TIRES

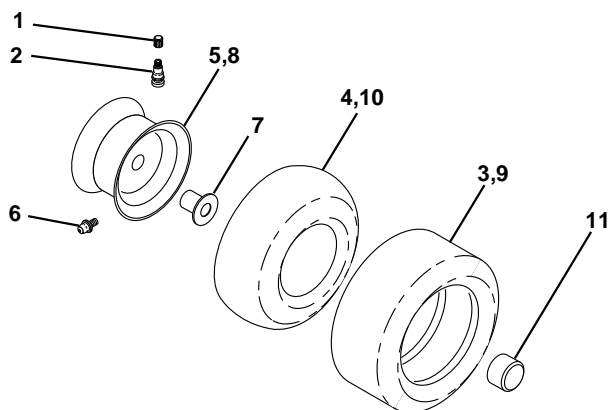

KEY NO.	PART NO.	DESCRIPTION
1	532 05 91-92	Cap Valve Tire
2	532 06 51-39	Stem Valve
3	532 10 62-22	Tire F Ts 15 X 6 0 - 6 Service
4	532 05 99-04	Tube Front (Service Item Only)
5	532 13 83-36	Rim Asm 6"front Silver Service
6	532 12 49-57	Fitting Grease (Front Wheel Only)
7	532 12 49-59	Bearing Flange (Front Wheel Only)
8	532 13 83-37	Rim Asm 8"rear Silver Service
9	532 12 20-82	Tire R Ts 20x10-8 C Service
10	532 12 49-26	Tube Rear (Service Item Only)
11	532 10 47-57	Cap Axle Blk 1 50 X 1 00
--	532 14 43-34	Sealant, Tire (10 oz. Tube)

NOTE: All component dimensions given in U.S. inches
1 inch = 25.4 mm

REPAIR PARTS

TRACTOR - MODEL NO. YTH150 (954140007A), PRODUCT NO. 954 14 00-07

ENGINE

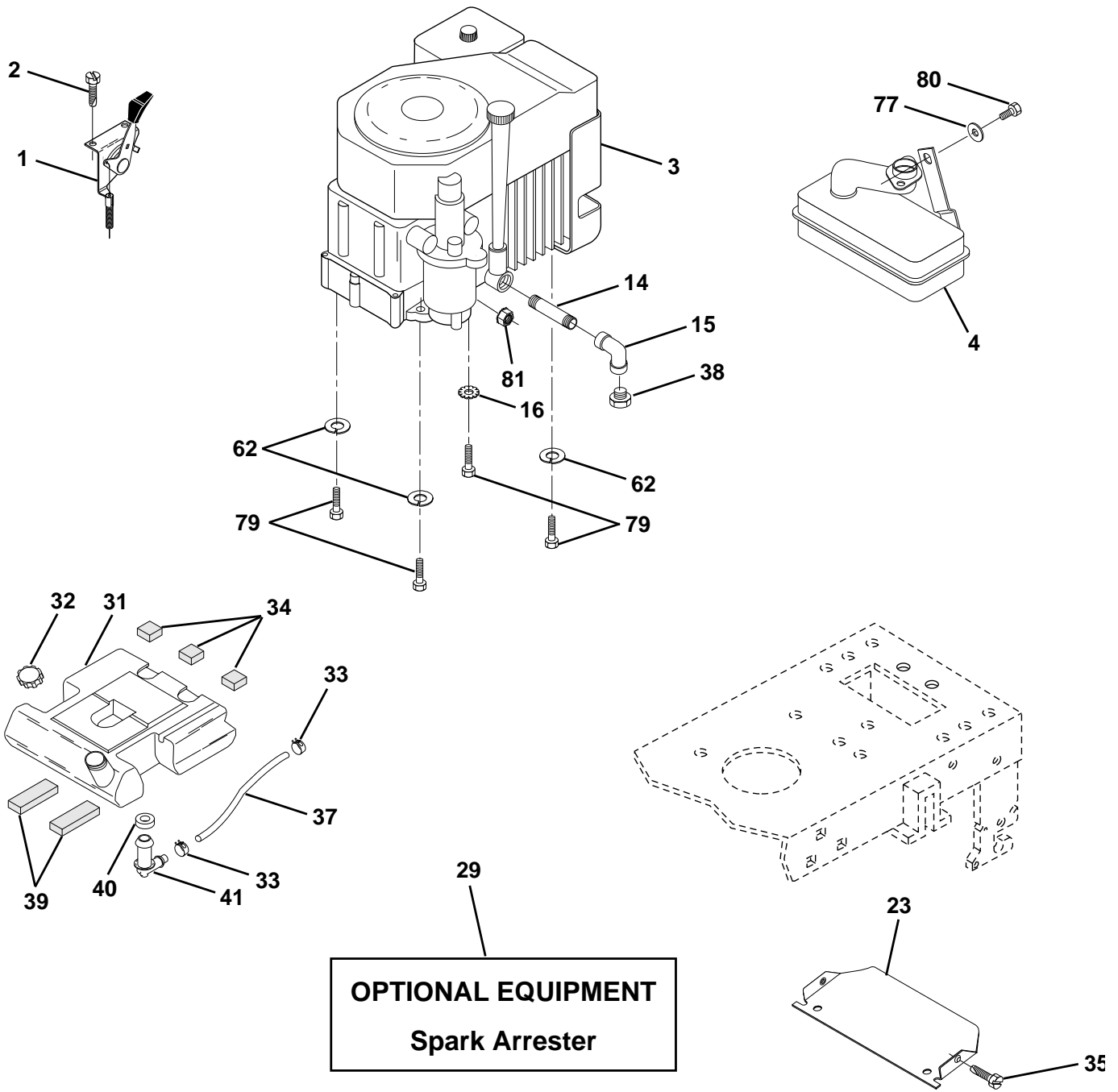

REPAIR PARTS

TRACTOR - MODEL NO. YTH150 (954140007A), PRODUCT NO. 954 14 00-07

ENGINE

KEY NO.	PART NO.	DESCRIPTION
1	532 14 12-96	Control Th/ch 27. LH. Flag Dom.
2	817 72 04-10	Screw Hex Thd Cut 1/4-20x5/8 T
3	-----	Engine Kohler Model No. CV15s
4	532 13 73-50	Muffler LT Kohler 12.5/15HP
14	813 28 03-28	Nipple Pipe 3/8 Npt X 3-1/2
15	813 20 03-00	Elbow Std 90 Degree 3/8-18 Npt
16	811 05 06-00	Washer Lock Ext Tooth 3/8
23	532 15 61-23	Shield Heat
29	532 13 71-80	Kit Spark Arrestor (Flat Scrn)
31	532 15 36-30	Tank Fuel 3.5 STLT W/O Sensor
32	532 14 05-27	Cap Asm Fuel W/sym Vented
33	532 12 34-87	Clamp Hose Black
34	532 10 60-82	Pad Spacer
35	817 49 05-12	Screw
37	532 12 49-23	Line Fuel 7.5"
38	-----	Plug Oil Drain (Order From Engine Manufacturer)
39	532 10 92-27	Pad Idler 1.75 x .75 x .06
40	532 12 49-52	Bushing
41	532 13 92-77	Stem Tank Fuel
62	810 04 05-00	Washer Lock Hvy Hlcl Spr 5/16
77	819 10 12-16	Washer 5/16 x 3/4 x 16 Ga.
79	532 12 53-98	Bolt Hex
80	874 76 05-08	Bolt Hex Hd. 5/16-18unc x 1/2
81	532 12 88-61	Nut Flange 1/4-20 Starter Nut

NOTE: All component dimensions given in U.S. inches
1 inch = 25.4 mm

REPAIR PARTS

TRACTOR - MODEL NO. YTH150 (954140007A), PRODUCT NO. 954 14 00-07

MOWER DECK

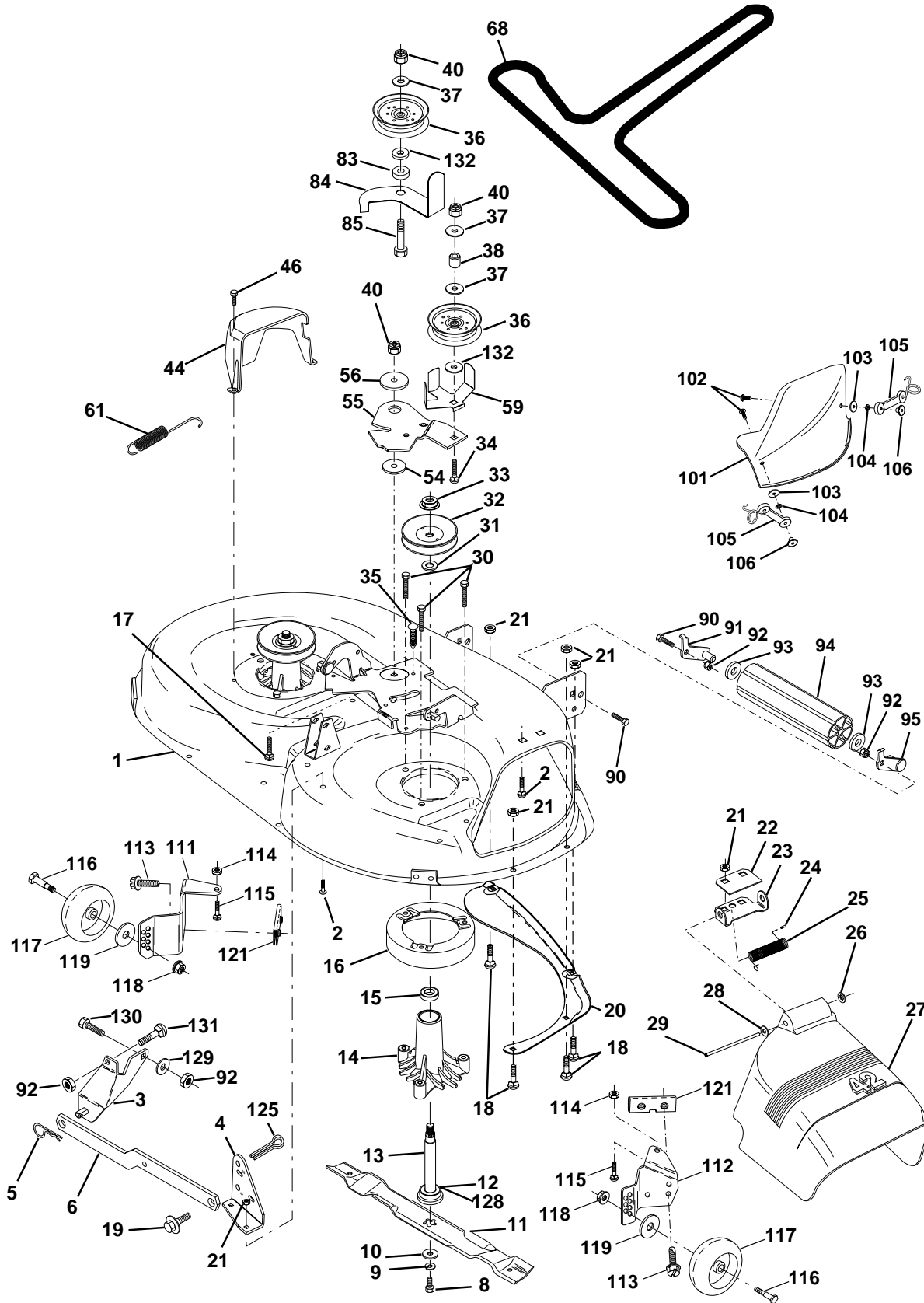

REPAIR PARTS

TRACTOR - MODEL NO. YTH150 (954140007A), PRODUCT NO. 954 14 00-07

MOWER DECK

KEY NO.	PART NO.	DESCRIPTION	KEY NO.	PART NO.	DESCRIPTION
1	532 14 43-93	Housing Asm Mower 42"94 T-Path	56	532 12 20-52	Spacer Retainer Pm Mower
2	872 14 05-06	Bolt Rdhd Sqnk 5/16-18unc X3/4	59	532 14 10-43	Guard, Belt
3	532 13 80-17	Bracket Asm Fr Sway Bar 38/42	61	532 13 19-50	Spring Ext. Elect
4	532 13 84-40	Bracket Asm Deck 42"sway Bar	68	532 14 42-00	V-Belt Mower
5	532 12 46-70	Retainer Spring	83	532 12 09-58	Washer Sintered
6	532 13 08-32	Arm Suspension Rear	84	532 15 60-84	Keeper 'Belt Idler
8	532 85 08-57	Bolt 3/8-24x1 25 Gr8 Patched	85	872 14 06-18	Bolt Carriage 3/8-16 x 2-1/4 Gr.5
9	810 03 06-00	Washer Lock Hvy 3/8 Unplated	90	874 76 06-16	Bolt Fin Hex 3/8-16unc X 1
10	532 14 02-96	Washer Hard Blade Mower Vented	91	532 13 22-74	Bracket Asm Noseroller LH
11	532 13 41-49	Blade Mower Mulching 42"	92	873 80 06-00	Nut Lock Hex w/ins. 3/8-16 UNC
12	532 12 98-95	Bearing Ball #6204 (Mandrel)	93	819 17 14-16	Washer 17/32 X 7/8 X 16 Ga
13	532 13 76-45	Shaft Asm W/lower Bearing	94	532 13 22-64	Roller Nose 38 & 42
14	532 12 87-74	Housing Mandrel Vented(machd)	95	532 13 22-73	Bracket Asm Noseroller RH
15	532 11 04-85	Bearing Ball Mandrel	101	532 13 64-20	Cover Mulching 42" Blk
16	532 14 03-29	Stripper Round Mower	102	871 16 10-10	Screw
17	872 11 06-18	Bolt Rdhd Sqnk 3/8-16 X 2-1/4	103	819 06 12-16	Washer #10
18	872 14 05-05	Bolt Carr 5/16-18 X 5/8	104	810 07 10-00	Washer Lock #10
19	532 13 28-27	Bolt Shoulder	105	532 13 07-58	Latch Asm Bagger
20	532 13 68-88	Baffle Vortex 42	106	532 12 50-04	Nut Weld .327/.304 #10-24
21	873 68 05-00	Nut Crown Lock 5/16-18	111	532 15 51-97	Bracket Wheel Gauge Lh 42" Deck
22	532 13 47-53	Stiffener Bracket 42"deck	112	532 15 51-98	Bracket Gauge Wheel Rh 42" Deck
23	532 13 12-67	Bracket Deflector Mower 42"	113	817 49 05-12	Screw Thdrol 5/16-18 x 3/4 TYT
24	532 10 53-04	Cap Sleeve 80x 112 Blk Mower	114	873 51 05-00	Nut Keps 5/16 - 18 UNC
25	532 12 37-13	Spring Torsion Deflector 2 52	115	872 11 05-04	Bolt Carriage 5/16 - Unc x 1/2
26	532 11 04-52	Nut Push Phos & Oil	116	532 13 76-44	Bolt Shld
27	532 13 09-68	Shield Deflector Mower 42" Blk	117	532 13 39-57	Wheel Gauge Donut
28	819 11 10-16	Washer 11/32 X 5/8 X 16 Ga	118	873 93 06-00	Nut Centerlock 3/8 - 16 UNC
29	532 13 14-91	Rod Hinge 42"6 75 Wlg	119	819 12 14-14	Washer 3/8 x 7/8 x 14 Ga.
30	532 13 87-76	Screw Thdrol Hex Hd Zinc Mwr.	121	532 14 37-23	Bracket
31	532 12 99-63	Washer Spacer Mower Vented	125	876 02 08-16	Cotter Pin
32	532 15 35-35	Pulley Mandrel 42"	128	532 15 33-90	Washer Felt
33	532 13 72-66	Nut 9/16top Lock Flng Cntr	129	819 13 13-12	Washer 13/32 x 13/16 x 12 Ga.
34	872 11 06-22	Bolt RDHD 3/8-16 UNC x 2-3/4 Gr. 5	130	874 78 06-16	Bolt Fin Hex 3/8-16unc x 1 Gr. 5
35	532 13 38-35	Fastner Christmas Tree	131	872 14 06-08	Bolt Rdhd Sqnk 3/8-16 UNC
36	532 13 14-94	Pulley Idler Flat 3 060	132	819 13 22-03	Washer 13/32 x 1-3/8 x 3 Ga.
37	819 13 13-16	Washer 13/32 X 13/16 X 16 Ga	--	532 14 54-52	Deck Serv 42" Elec Vent (Standard Deck - Order Nose Roller, Gauge Wheel and Mulcher Plate components separately Key Nos. 90-95, 101-106 and 111-121)
38	532 13 28-23	Spacer Spring Stop Idler	--	532 13 07-94	Mandrel Assembly (Includes Key Numbers 8-10, 12-15, 31 and 33)
40	873 68 06-00	Nut Lock 3/8-16 Unc			
44	532 14 00-88	Guard Mandrel LH Black			
46	532 13 77-29	Screw Thdrol 1/4-20x5/8			
54	532 13 39-43	Washer Hardened			
55	532 14 00-84	Arm Idler 42"mower LT/YT			

NOTE: All component dimensions given in U.S. inches
1 inch = 25.4 mm

REPAIR PARTS

TRACTOR - MODEL NO. YTH150 (954140007A), PRODUCT NO. 954 14 00-07

MOWER LIFT

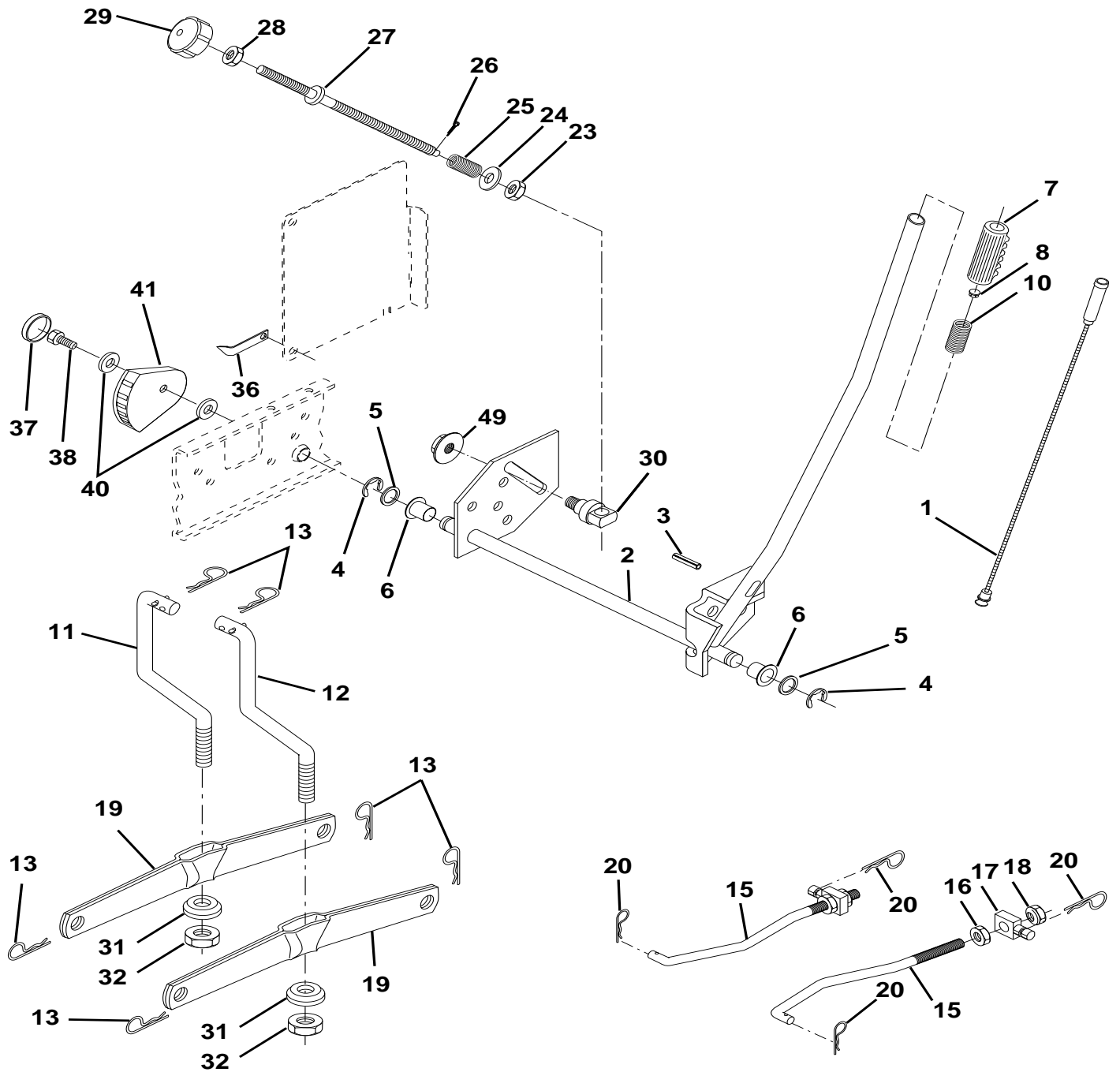

REPAIR PARTS

TRACTOR - MODEL NO. YTH150 (954140007A), PRODUCT NO. 954 14 00-07

MOWER LIFT

KEY NO.	PART NO.	DESCRIPTION
1	532 13 69-73	Wire Asm Inner W/plunger 17.32
2	532 14 51-17	Shaft Asm Lift RH w/Inf
3	532 10 57-67	Pin Groove 1 500 Zinc
4	812 00 00-02	E Ring #5133-62
5	819 21 16-21	Washer 21/32 X 1 X 21 Ga
6	532 12 01-83	Bearing Nylon Blk 629 Id
7	532 12 56-31	Grip Handle Fluted Blk
8	532 12 45-26	Button Plunger Black
10	532 12 25-12	Spring Cprsn 3 750 Oiled
11	532 13 98-65	Link Lift LH Fixed Length
12	532 13 98-66	Link Lift RH Fixed Length
13	532 12 46-70	Retainer Spring
15	532 12 72-18	Link Front
16	873 35 08-00	Nut Jam Hex 1/2-13 Unc
17	532 13 01-71	Trunnion Blk Zinc
18	873 80 08-00	Nut Lock W/wsh 1/2-13unc
19	532 13 98-68	Arm Suspension Rear
20	532 12 46-60	Retainer Spring
23	532 11 08-07	Nut Special
24	819 13 10-16	Washer 13/32 X 5/8 X 16 Ga
25	532 12 48-74	Spring 2-1/8"
26	876 02 03-08	Pin Cotter 3/32 X 1/2
27	532 12 69-71	Rod Adj Lift Zinc 7.49 Wrk Lg
28	873 35 06-00	Nut Hex Jam 3/8-16 Unc
29	532 13 80-57	Knob Inf 3/8-16 Unc Blk W/sym
30	532 15 02-33	Trunnion Infin Height
31	532 14 03-02	Bearing Pvt Lift Spherical
32	873 54 06-00	Nut Crownlock 3/8 - 24
36	532 15 50-97	Pointer Height Indicator
37	532 12 39-35	Plug Hole Blk 1.485/1.515 Dia.
38	817 49 05-12	Screw Thdrol 5/16-18 x 3/4
40	819 11 24-10	Washer 11/32 x 1-1/2 10 Ga.
41	532 15 50-98	Indicator Height STLT
49	532 14 52-12	Nut Hex Flange Lock

NOTE: All component dimensions given in U.S. inches
1 inch = 25.4 mm

REPAIR PARTS

TRACTOR - MODEL NO. YTH150 (954140007A), PRODUCT NO. 954 14 00-07
HYDRO TRANSAXLE - MODEL NUMBER 310-0650

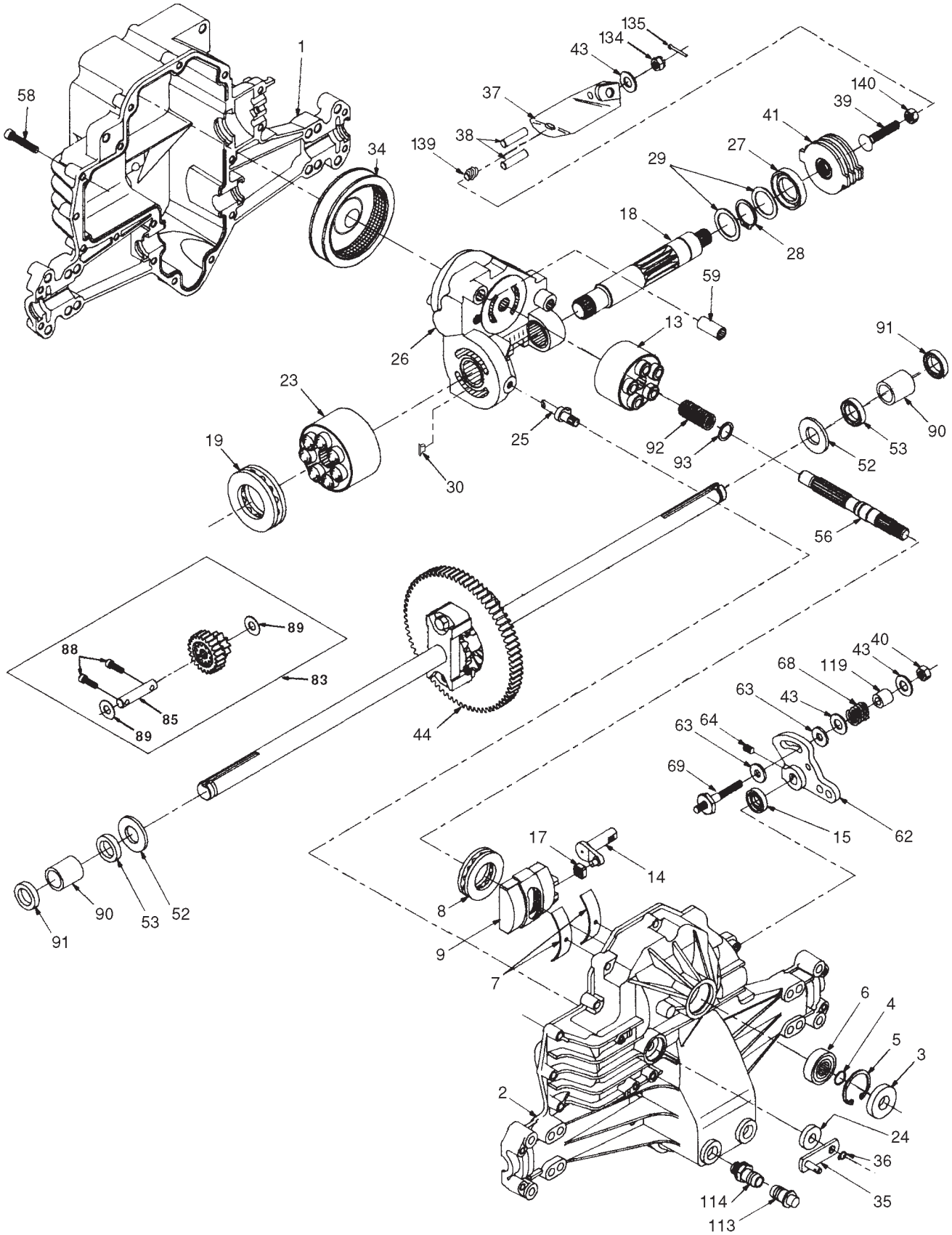

REPAIR PARTS

TRACTOR - MODEL NO. YTH150 (954140007A), PRODUCT NO. 954 14 00-07

HYDRO TRANSAXLE - MODEL NUMBER 310-0650

KEY PART NO. NO.	DESCRIPTION	KEY PART NO. NO.	DESCRIPTION		
1	532 14 29-30	Housing, Lower	43	532 14 28-84	Washer 7/16 x 7/8 x .060
2	532 14 29-31	Assembly, Upper Housing	44	532 15 08-29	Differential Assembly
3	532 14 29-32	Seal, Lip	52	532 14 29-91	Washer 3/4 x 1.5 x .13
4	532 14 29-28	Ring, Wire Retaining	53	532 14 29-61	Seal .75 x 1.25 x .250
5	532 14 29-33	Ring, Retaining	56	532 14 29-63	Shaft, Input
6	532 14 29-34	Bearing, Shaft Ball	58	532 14 29-64	Bolt 1/4-20 x 1.38
7	532 14 29-35	Bearing, Cradle	59	532 14 29-65	Pin .5 OD x .43 ID x .750
8	532 15 07-71	Bearing, Thrust 30 x 52 x 13	62	532 14 29-66	Arm, Control
9	532 14 29-37	Swashplate, Variable	63	532 14 29-67	Puck, Dampener
13	532 14 29-38	Block, Cylinder Assembly	64	532 14 29-20	Set Screw
14	532 14 29-39	Arm, Trunnion	68	532 14 29-69	Spring
15	532 14 29-40	Seal, Lip	69	532 14 46-10	Stud 5/16-24
17	532 14 29-41	Guide, Slot	83	532 14 29-71	Jackshaft Assembly
18	532 15 07-72	Shaft, Motor	85	532 15 08-06	Jackshaft
19	532 15 07-73	Bearing, Thrust 42 x 68 x 16	88	532 14 29-73	Screw, Cap
23	532 14 29-44	Block, Cylinder Assembly	89	532 14 29-74	Washer 7/16 x 1 x 1/2
24	532 14 29-45	Seal, Lip 10 x 25 x 7	90	532 14 29-75	Sleeve Bearing
25	532 14 29-46	Actuator, Bypass	91	532 14 29-76	Seal, Wiper
26	532 15 07-74	Center Section Assembly Kit	92	532 14 29-77	Spring, Block
27	532 14 29-48	Seal, Lip 26 x 42 x 8	93	532 14 29-78	Washer, Block Thrust
28	532 14 29-49	Ring, Retaining	113	532 14 29-17	Cap, Vent Assembly
29	532 14 29-50	Washer 26 x 35 x 1	114	532 14 29-18	Fitting, O-Ring Assembly
34	532 14 29-51	Oil Filter Element	119	532 14 29-80	Spacer
35	532 14 29-52	Arm, Bypass	134	532 14 46-07	Nut, Castle 5/16-24
36	532 14 29-53	Ring, Retaining	135	532 14 46-08	Pin, Cotter
37	532 14 29-54	Arm, Actuating	139	532 15 07-75	Spring, Compression
38	532 14 29-55	Pin, Actuating	140	532 15 07-76	Nut, Hex 5/16-24
39	532 15 07-77	Bolt 5/16-24 x 1-3/4			
40	532 15 07-78	Locknut, Hex 5/16-24 UNJC			
41	532 14 29-58	Brake Rotor/Stator Kit			

NOTE: All component dimensions given in U.S. inches
1 inch = 25.4 mm