

YTH 150

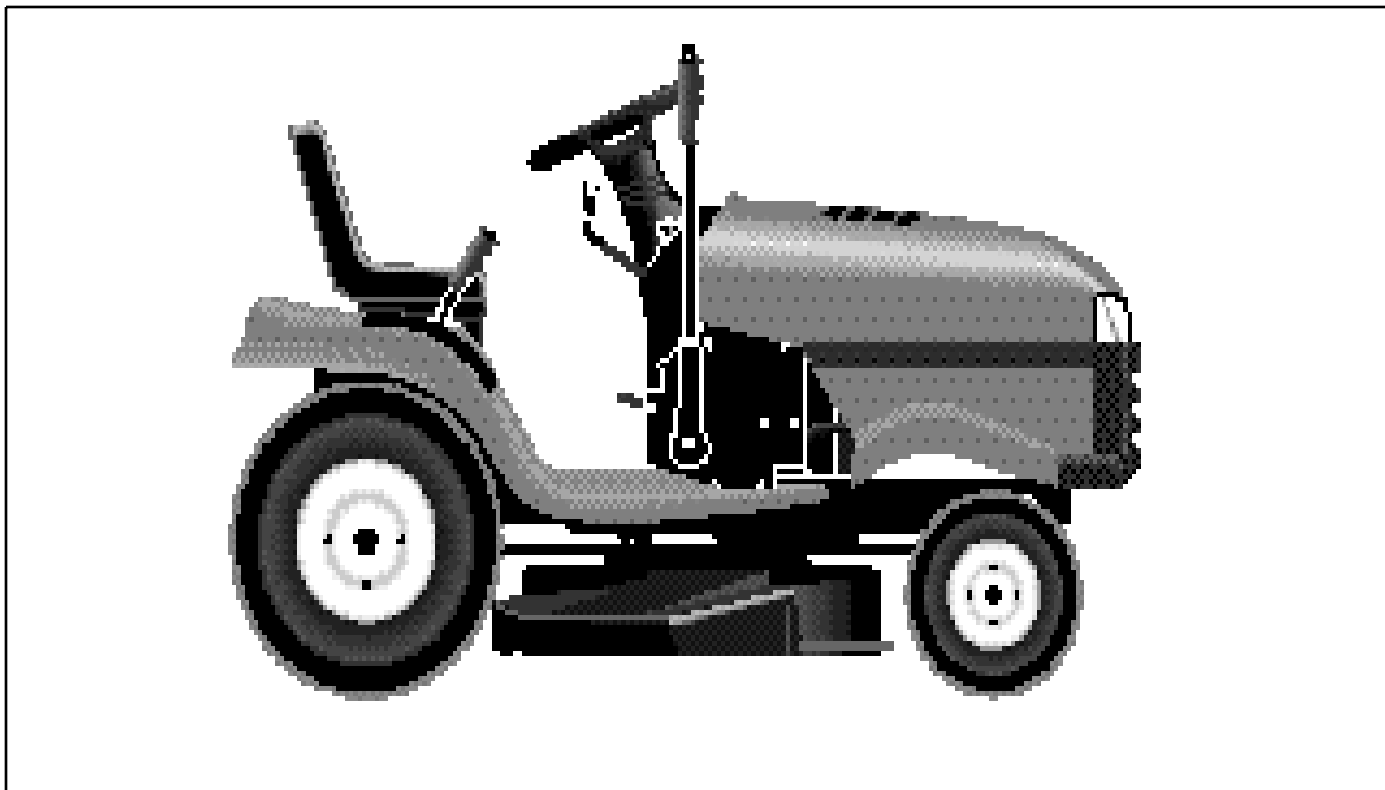

1.1997
Spare Parts

954 14 00 07B

REPAIR PARTS

TRACTOR - MODEL NO. YTH150 (954140007B), PRODUCT NO. 954 14 00-07

ELECTRICAL

KEY NO.	PART NO.	DESCRIPTION
1	532144925	Battery 12 Volt 25 AMP
2	874760412	Bolt Hex Hd 1/4-20unc X 3/4
3	819091016	Washer 9/32 X 5/8 X 16 Ga.
4	810040400	Washer Lock Hvy Helical 1/4
6	873220400	Nut Fin Hex 1/4-20 Unc
7	532007697	Tube Plastic 46"
8	532124886	Tray Battery 7.80 x 5.25 Blk
9	532109596	Clamp Hose Olive
10	532145211	Bolt Btr Frt 1/2-20 x 7.5 Zinc
11	532150109	Holddown Battery Front Mount
12	532145769	Nut Push Nylon 1/4" Battery Frt
16	532153664	Switch Interlock Push-In
19	810090400	Washer Lock 1/4
20	873350400	Nut Jam Hex 1/4-20 Unc
21	532136850	Harness Asm Light W/4152j
22	532004152	Bulb Light #1156
24	532124780	Cable Battery 6 Ga 11" red
25	532146148	Cable Battery 6 Ga 44" red w/16 wire
26	532108824	Fuse 30 AMP Auto Green
28	532145491	Cable Ground 6 Ga 21" black
29	532121305	Switch Plunger Nc Gray
30	532140301	Switch Ign 4 pos w/lights
31	532124211	Nut Ignition
32	532141226	Cover Sw Ignition
33	532122147	Key Ign Modelled Generic
40	532156443	Harness Ign.
41	871110408	Bolt Blk Fin Hex 1/4 - 20 x 1/2
42	532131563	Cover Terminal Red
43	532145673	Solenoid
44	873640400	Nut Keps Hex 1/4-20 Unc
45	532121433	Ammeter Rectangular 6 Amp
46	532110940	Meter Hour
47	817011008	Screw 10-24 x 1/2 Black
50	532154959	Switch PTO 3PDT Black Delta 96
51	532140405	Ring Retainer PTO
55	817490508	Screw Thdrol 5/16-18 x 1/2 Tyt
70	532142621	Harness, Eng Kohl Cmd-L Dual
80	532146685	Harness Clutch Evx

NOTE: All component dimensions given in U.S. inches.
1 inch = 25.4 mm.

REPAIR PARTS

TRACTOR - MODEL NO. YTH150 (954140007B), PRODUCT NO. 954 14 00-07

CHASSIS AND ENCLOSURES

KEY NO.	PART NO.	DESCRIPTION
1	532159527	Chassis Weldment
2	532140356	Drawbar, Stretch
3	817490612	Screw Thdrol 3/8-16x3/4 Ty-tt
4	819131216	Washer 13/32 x 3/4 x 16 Ga.
5	532155272	Bumper Hood/Dash
9	532156490	Dash Slkscr.Plm.E.A.Hm.Nc.Sym
10	872140608	Bolt Carriage 3/8-16 x 1
11	532155927	Panel Dash Lh
13	532153913	Panel Dash Rh
14	817490608	Screw Thdrol 3/8-16x1/2 Ty-tt
17	532156051	Hood LT/PL Husqvarna
20	532156437	Plate Mtg Battery Fuel Tank Fr
23	532124028	Bushing
25	819131312	Washer 13/32 X 13/16 X 12 Ga
26	873800600	Nut Lock Hex W/Ins 3/8-16 Unc
28	532149776	Grille LT/PL Husqvarna
29	532149777	Lens LT/PL Husqvarna
30	532156489	Fender Footrest STLT Pnt
31	532139976	Bracket Support Fender
37	817490508	Screw Thdrol 6/16-18 x 1/2 TYT
38	532139886	Bracket, Asm. Pivot, L.H., Mower Rear
39	532139887	Bracket, Asm. Pivot, R.H., Mower Rear
51	873800400	Nut Lock Hex W/Ins 1/4-20
52	819091416	Washer 9/32 x 7/8 x 16 Ga.
53	532150067	Bracket Pnt. Pick off LT/PL Husqvarna
57	874780412	Bolt Hex 1/4-20 x 3/4
58	532150127	Air Duct Engine P/L
60	872140606	Bolt Rdhd Sqnk 3/8-16unc x 3/4
64	532154798	Dash Lower STLT
71	873680400	Nut Crownlock 1/4-20 UNC
74	873680600	Nut Crownlock 3/8-16 UNC
80	532155854	Latch Hood Plm Husqvarna
109	532141461	Bracket Extension Bumper
110	532143679	Plug Plastic
113	532150300	Bumper Asm.
115	817490620	Screw Thdrol 3/8-16 x 1-1/4
122	532157301	Bracket Shift Stlt
123	532152927	Screw TT #10-32.5.3/8 Flange
129	819091016	Washer 9/32 x 5/8 x 16 Ga.
134	532150132	Rod Support Hood LT/PL Husq.
140	532158418	Bracket Suspension Front
142	532156095	Plate Reinforcement STLT
143	532154966	Bracket Swaybar Chassis
144	532154207	Bracket Pnt Footrest STLT
145	532156524	Rod Pivot Chassis/Hood
147	874760412	Bolt Hex Hd 1/4-20 UNC 3/4

NOTE: All component dimensions given in U.S. inches
1 inch = 25.4 mm

REPAIR PARTS

TRACTOR - MODEL NO. YTH150 (954140007B), PRODUCT NO. 954 14 00-07

DRIVE

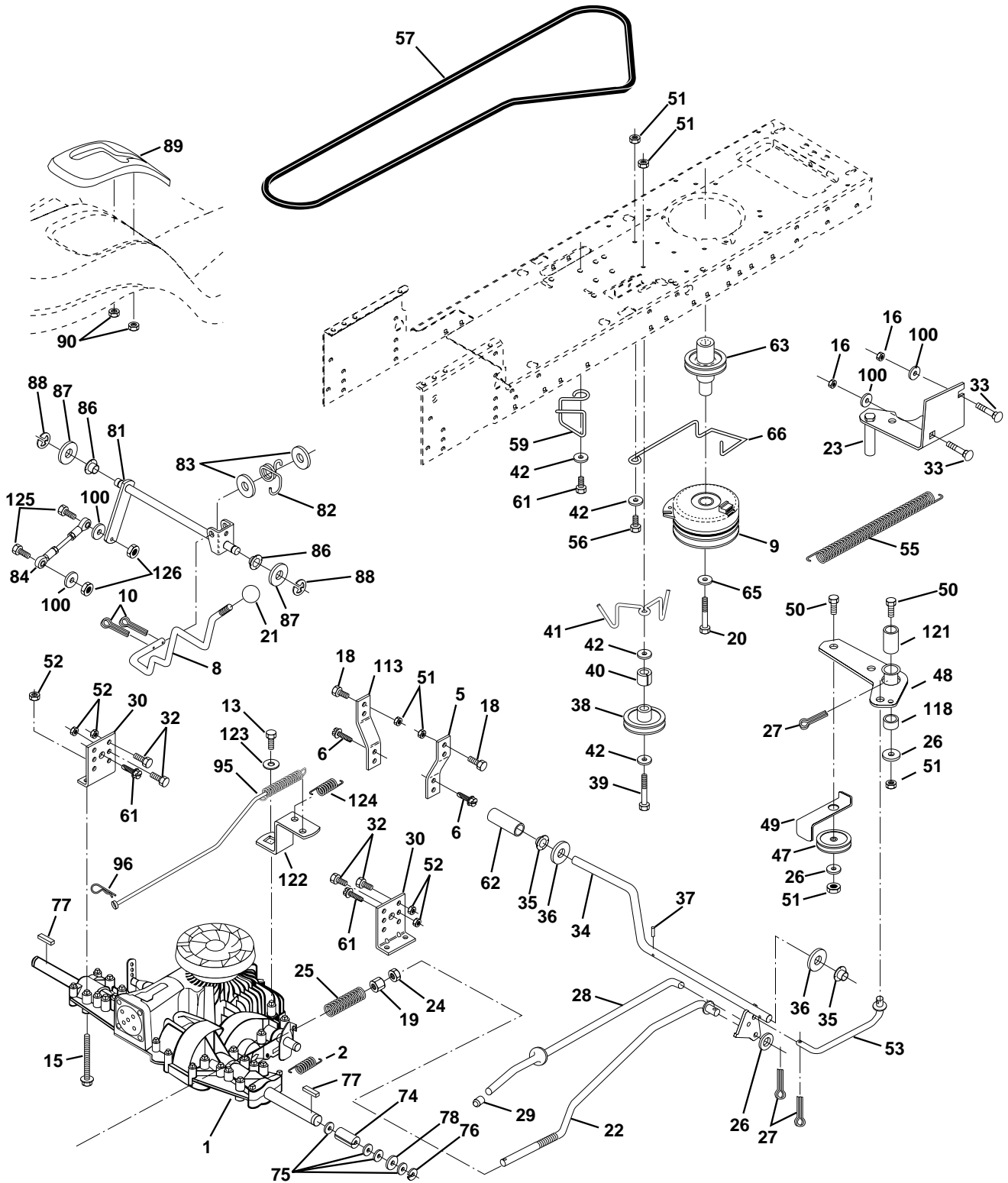

REPAIR PARTS

TRACTOR - MODEL NO. YTH150 (954140007B), PRODUCT NO. 954 14 00-07

DRIVE

KEY PART NO. NO.	DESCRIPTION	KEY PART NO. NO.	DESCRIPTION
1	-----	51	873680600 Nut
2	532146682	52	873680500 Nut Crown Lock 5/16-18
5	532121520	53	532105710 Link, Clutch
6	817490512	55	532105709 Spring, Return, Clutch
8	532154792	56	874760620 Bolt, Fin Hex 3/8-16 UNC x 1 1/4
9	532145028	57	532156971 V-Belt, Ground Drive
10	876020416	59	532140312 Keeper, Center Span
13	874550412	61	817490612 Screw Thdrol. 3/8-16 x 3/4 Ty. TT
15	874490544	62	532123533 Cover, Pedal Premium
16	873800500	63	532145868 Pulley, Clutch
18	874780616	65	810040700 Washer Lock Hvy HLCL Spr 7/16
19	873800600	66	532154778 Keeper Belt Engine
20	532150280	74	532156972 Spacer, Split
21	532140845	75	532121749 Washer 25/32 x 1-1/4 x 16 Ga.
22	532130804	76	812000001 E-Ring
23	532154978	77	532123583 Key, Square
24	873350600	78	532121748 Washer 25/32 x 1-5/8 x 16 Ga
25	532106888	81	532156969 Shaft Asm. Cross Hydro 20" Tires
26	819131316	82	532123782 Spring Torsion T/A
27	876020412	83	819171216 Washer 17/32 x 3/4 x 16 Ga.
28	532145204	84	532156962 Rod, Tie Hydro 20" Tires SPH Ball 4.75
29	532071673	86	532071208 Bushing Rod Strig. 629/632 ID
30	532130807	87	819212016 Washer 21/32 x 1-1/4 x 16 Ga.
32	874760512	88	812000008 Ring Klip #5304-62
33	872140506	89	532154882 Console, Hydro STLT
34	532155071	90	532124346 Nut Self-Thd Wsh-Hd 1/4 Zinc
35	532120183	95	532156970 Control Asm. Bypass Hydro
36	819211616	96	532124788 Retainer Spring 1" Zinc/Cad
37	532124963	100	819111216 Washer 11/32 x 3/4 x 16 Ga.
38	532123674	118	532154774 Spacer Bellcrank
39	874760644	121	532154419 Nyliner Clutching STL
40	532124965	122	532156963 Plate Bypass PVST
41	532154777	123	819091016 Washer 9/32 x 5/8 x 16 Ga.
42	819131312	124	532156967 Spring Return PVST
47	532127783	125	874750516 Bolt Fin Hex 5/16-18 UNC x 1
48	532154604	126	532124949 Nut Lock 5/16-18 UNC
49	532123205		
50	874760624		

NOTE: All component dimensions given in U.S. inches
1 inch = 25.4 mm

REPAIR PARTS

TRACTOR - MODEL NO. YTH150 (954140007B), PRODUCT NO. 954 14 00-07

STEERING ASSEMBLY

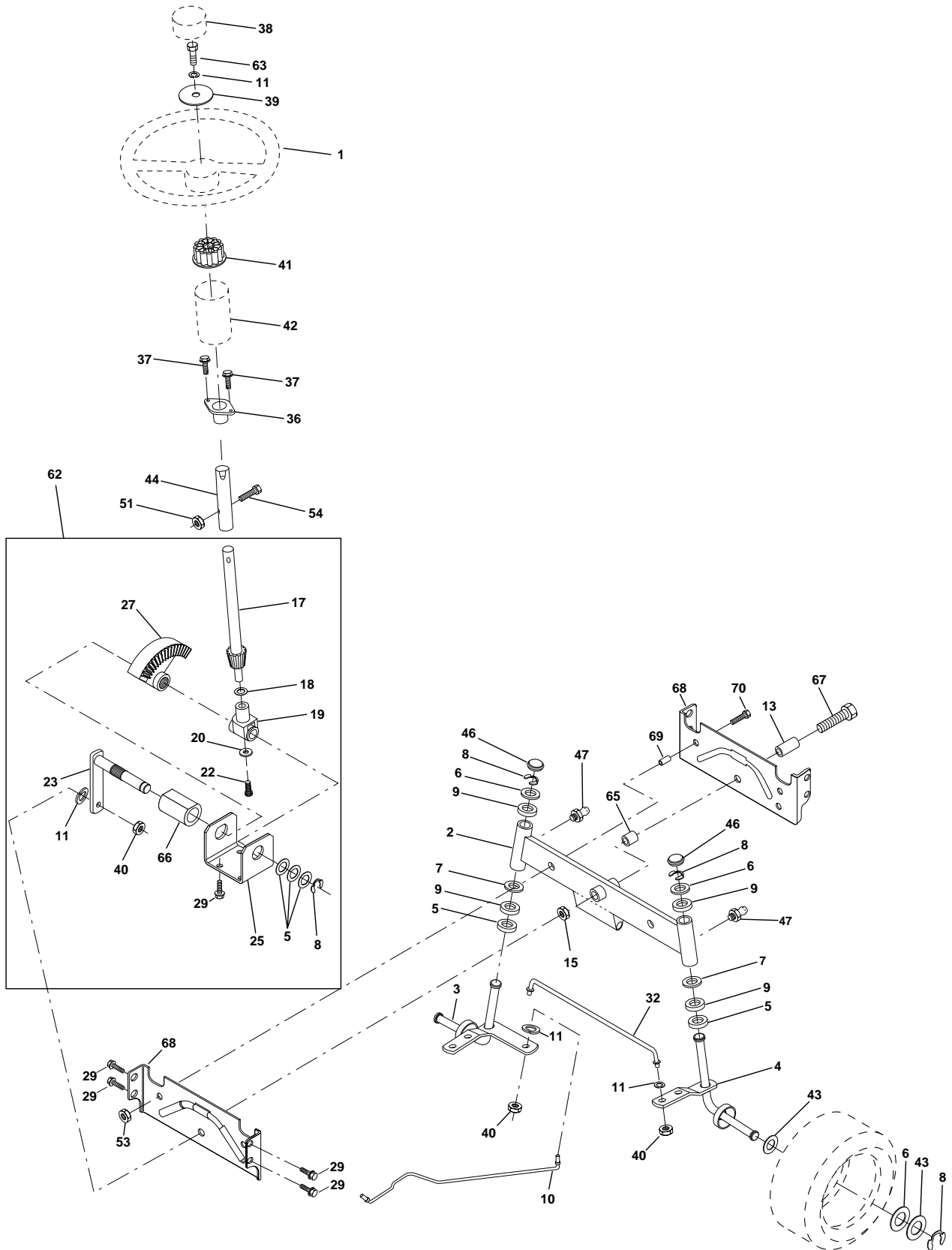

REPAIR PARTS

TRACTOR - MODEL NO. YTH150 (954140007B), PRODUCT NO. 954 14 00-07

STEERING ASSEMBLY

KEY NO.	PART NO.	DESCRIPTION
1	532124415	Wheel Steering
2	532137094	Axle Front Casting Machined
3	532157479	Spindle Asm LH
4	532157478	Spindle Asm RH
5	532124931	Bearing Race Thrust Harden
6	532121748	Washer 25/32 X 1-5/8 X 16 Ga
7	819272016	Washer 27/32 X 1-1/4 X 16 Ga
8	812000029	Ring Klip #t5304-75
9	532124937	Bearing Col Strg Blk
10	532154432	Link Drag Extended Cast
11	810040600	Washer Lock Hvy Hlcl Spr 3/8
13	532154779	Bearing Axle STLT/GT
15	873901000	Nut Lock Flange 5/8-11 Unc
17	532156546	Shaft Asm Strg
18	532057079	Washer Thrust 515x 750x 033
19	532124035	Support Shaft
20	532126684	Washer Shim 1/4 X 5/8 X 062
22	871200410	Screw Hex Sckt 1/4-20 x 5/8
23	532127501	Shaft Asm Pittman
25	532154406	Bracket Steering
27	532136874	Gear Sector
29	817490612	Screw Thdrol 3/8-16x3/4 Ty-tt
32	532137347	Rod Asm Tie Ball Adj. VGT
36	532155099	Bushing Strg
37	532152927	Screw
38	532124416	Insert Cap Strg Wh Au
39	819133808	Washer 13/32 X 2-3/8 X 8 Ga
40	532124701	Lock nut
41	532100711	Adaptor Wheel Strg
42	532155092	Boot Steering Shaft
43	532121749	Washer 25/32 X 1 1/4 X 16 Ga
44	532153720	Extension Steering Shaft LR/LT
46	532121232	Cap Spindle Fr Top Blk
47	532124836	Fitting Grease
51	873800500	Nut Lock Hex w/Ins 5/16-18
53	873680600	Nut Crownlock 3/8-16 UNC
54	874780520	Bolt Fin Hex 5/16-18 Unc x 1-1/4
62	532156594	Kit, Steering Assembly Svc
63	874780616	Bolt Fin Hex 3/8-16unc x 1 Gr. 5
65	532154780	Spacer Axle
66	532154404	Bearing Arm Pittman
67	874781044	Bolt, Fin Hex 5/8-11 UNC x 2-3/4
68	532154429	Brace, Axle
69	532160367	Spacer Brace Axle
70	874780636	Bolt Fin Hex 3/8-16 UNC x 2-1/4

NOTE: All component dimensions given in U.S. inches.
1 inch = 25.4 mm.

REPAIR PARTS

TRACTOR - MODEL NO. YTH150 (954140007B), PRODUCT NO. 954 14 00-07

SEAT ASSEMBLY

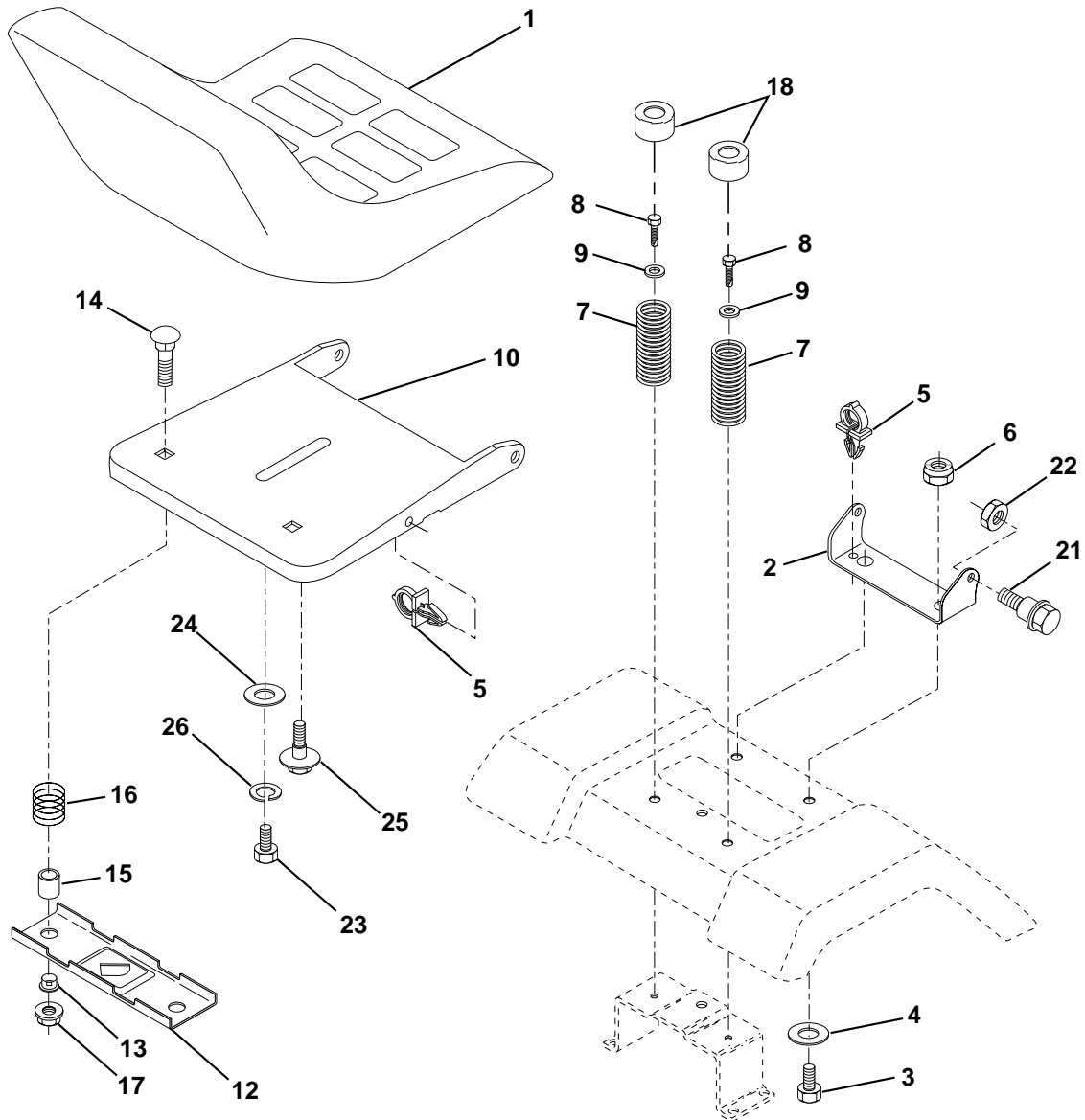

KEY PART NO. NO.

DESCRIPTION

1	532140839	Seat
2	532140551	Bracket Pivot Seat 8 720
3	874760616	Bolt Fin Hex 3/8-16unc X 1
4	819131610	Washer 13/32 X 1 X 10 Ga
5	532145006	Clip Push-In
6	873800600	Nut Hex w/Ins. 3/8-16 Unc
7	532124181	Spring Seat Cprsn 2 250 Blk Zi
8	817490616	Screw Thdrol 3/8-16 X 1 Ty-tt
9	819131614	Washer 13/32 X 1 X 14 Ga.
10	532155925	Pan Seat
12	532121246	Bracket Mounting Switch
13	532121248	Bushing Snap Blk Nyl 50 Id
14	872050411	Bolt Rdhd Sqkn 1/4-20x1-3/8

KEY PART NO. NO.

DESCRIPTION

15	532134300	Spacer Split 28x 96 Yel Zinc
16	532121250	Spring Cprsn 1 27 Blk Pnt
17	532123976	Nut Lock 1/4 Lge Flg Gr 5 Zinc
18	532124238	Cap Spring Seat
21	532153236	Bolt Shoulder 5/16-18 Unc
22	873800500	Nut Hex Lock W/Ins 5/16-18
23	874780814	Bolt, Hex Head, Fin 1/2-13 x 7/8 Grade 5
24	819171912	Washer 17/32 X 1-3/16 X 12 Ga.
25	532127018	Bolt Shoulder 5/16-18 X 62
26	810040800	Washer Lock

NOTE: All component dimensions given in U.S. inches.
1 inch = 25.4 mm

REPAIR PARTS

TRACTOR - MODEL NO. YTH150 (954140007B), PRODUCT NO. 954 14 00-07

DECALS

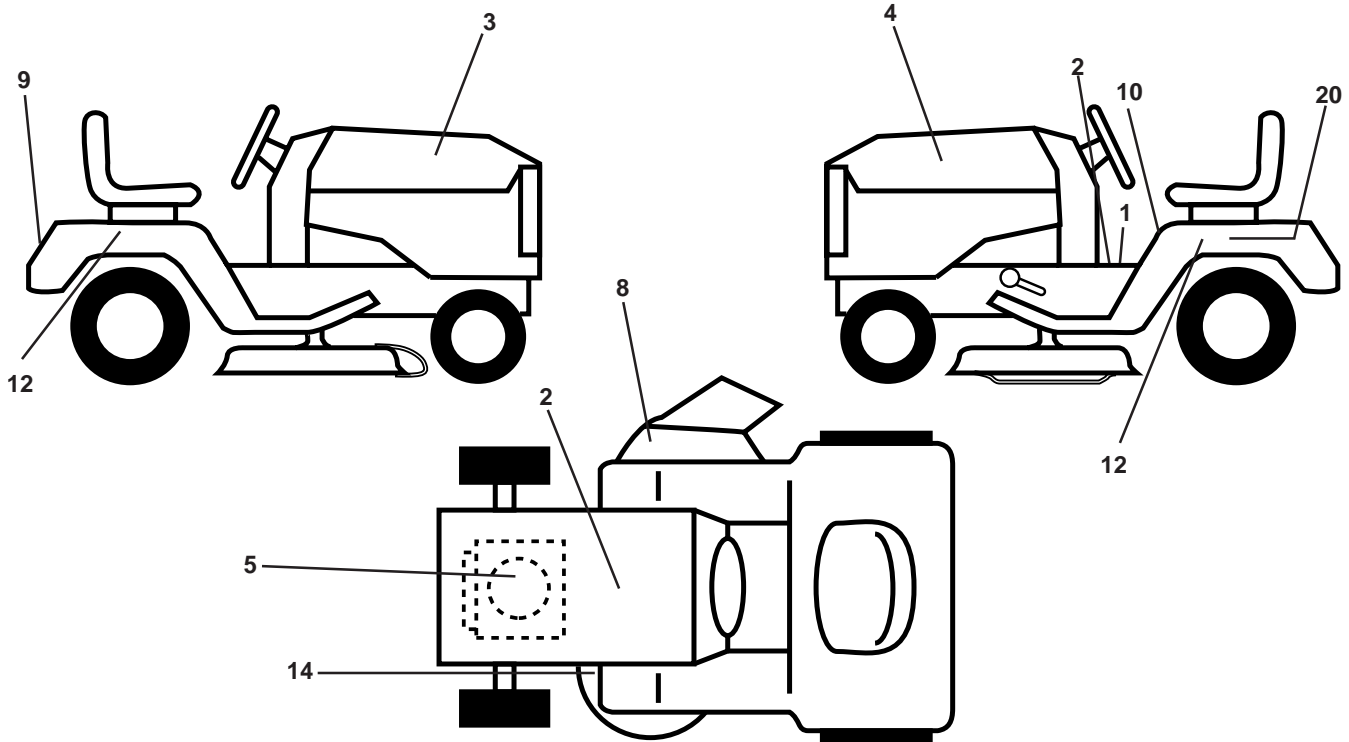

KEY NO.	PART NO.	DESCRIPTION
1	532157032	Decal Oper. Step Thru E/F
2	532145005	Decal Battery
3	532150730	Decal Hood LH
4	532150729	Decal Hood RH
5	532151244	Decal HP Engine
8	532137259	Decal Warning Multi-Languages
9	532150617	Decal Fender Husq
10	532157140	Decal Fender Danger E/F
12	532157007	Decal Fender Auto Husq Radius
14	532160396	Decal V-Belt Schematic
--	532154515	Pad Footrest LH STLT
--	532142341	Decal Drawbar Cntrl Mvt Hyd LT
--	532154516	Pad Footrest RH STLT

KEY NO.	PART NO.	DESCRIPTION
--	532138311	Decal Handle Lft Height Adjust
--	532160155	Manual Owner's (English)
--	532160156	Manual Owner's (French)

Available accessories not included with tractor:

--	MK420	Mulcher Kit with Blades
--	C42	Grass Catcher
--	LSB42	42" Snow Blower
--	LC05	Wheel Wts. (Pair)
--	LC06	Tire Chains 20 x 10 x 8
--	LBD48	48" Snow Blade

WHEELS & TIRES

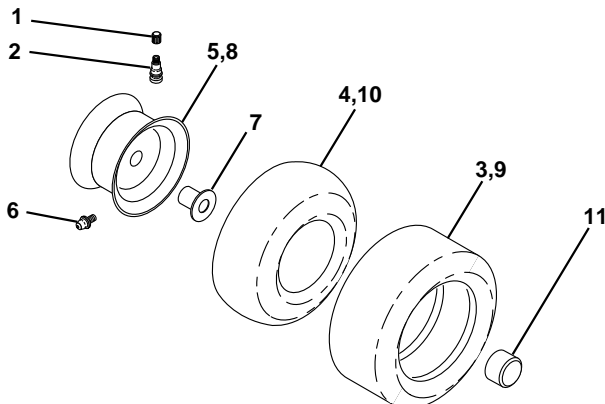

KEY NO.	PART NO.	DESCRIPTION
1	532059192	Cap Valve Tire
2	532065139	Stem Valve
3	532106222	Tire F Ts 15 X 6 0 - 6 Service
4	532059904	Tube Front (Service Item Only)
5	532138336	Rim Asm 6"front Silver Service
6	532124957	Fitting Grease (Front Wheel Only)
7	532124959	Bearing Flange (Front Wheel Only)
8	532138337	Rim Asm 8"rear Silver Service
9	532122082	Tire R Ts 20x10-8 C Service
10	532124926	Tube Rear (Service Item Only)
11	532104757	Cap Axle Blk 1 50 X 1 00
--	532144334	Sealant, Tire (10 oz. Tube)

NOTE: All component dimensions given in U.S. inches
1 inch = 25.4 mm

REPAIR PARTS

TRACTOR - MODEL NO. YTH150 (954140007B), PRODUCT NO. 954 14 00-07

ENGINE

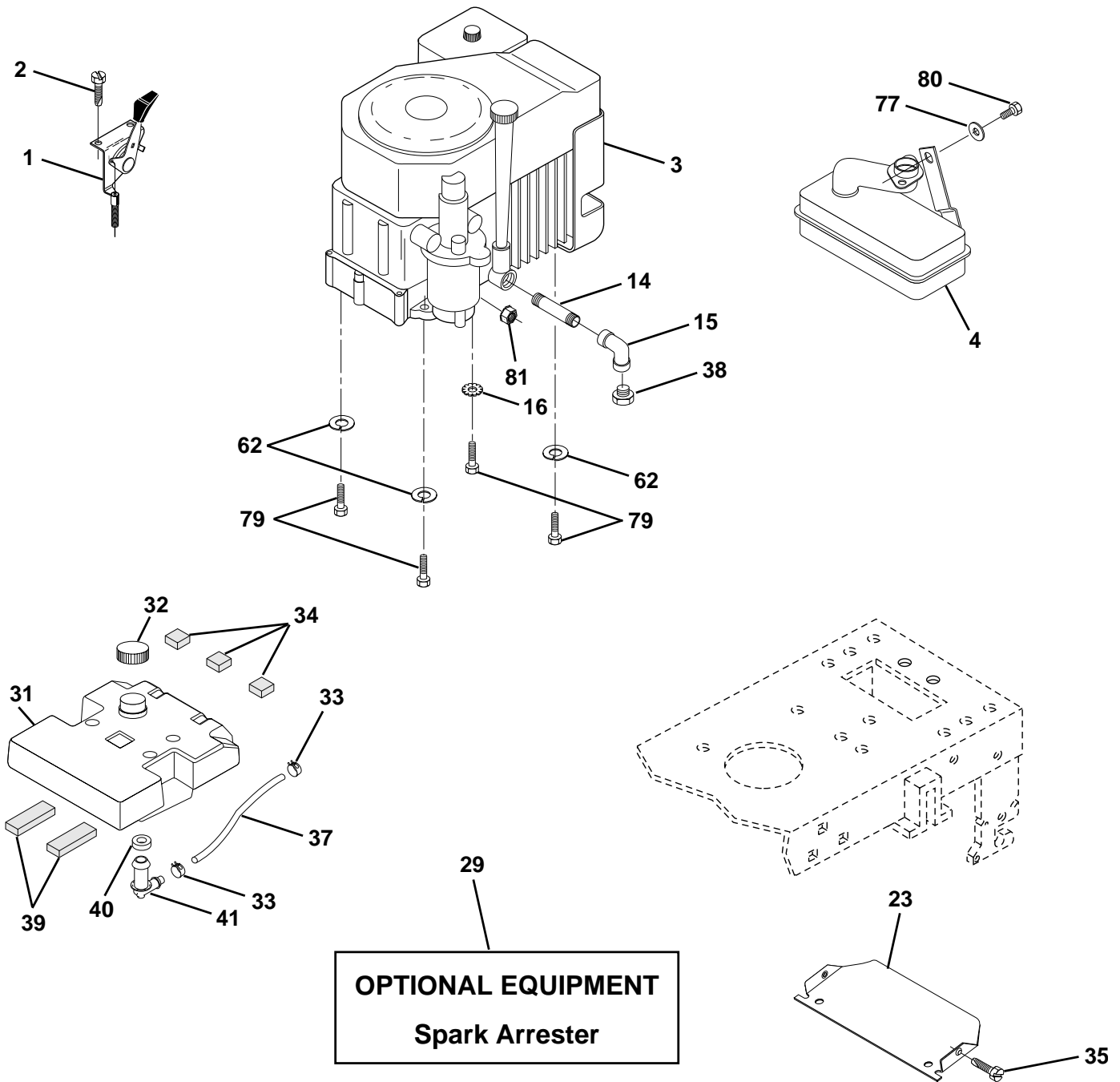

REPAIR PARTS

TRACTOR - MODEL NO. YTH150 (954140007B), PRODUCT NO. 954 14 00-07

ENGINE

KEY NO.	PART NO.	DESCRIPTION
1	532141296	Control Th/ch 27. LH. Flag Dom.
2	817720410	Screw Hex Thd Cut 1/4-20x5/8 T
3	-----	Engine Kohler Model No. CV15s
4	532137350	Muffler LT Kohler 12.5/15HP
14	813280328	Nipple Pipe 3/8 Npt X 3-1/2
15	813200300	Elbow Std 90 Degree 3/8-18 Npt
16	811050500	Washer Lock Ext Tooth 5/16
23	532156123	Shield Heat
29	532137180	Kit Spark Arrestor (Flat Scrn)
31	532157103	Tank Fuel 3.5 STLT W/O Sensor
32	532140527	Cap Asm Fuel W/sym Vented
33	532123487	Clamp Hose Black
34	532106082	Pad Spacer
35	817490512	Screw
37	532124923	Line Fuel 7.5"
38	-----	Plug Oil Drain (Order From Engine Manufacturer)
39	532109227	Pad Idler 1.75 x .75 x .06
40	532124952	Bushing
41	532139277	Stem Tank Fuel
62	810040500	Washer Lock Hvy Hlcl Spr 5/16
77	819101216	Washer 5/16 x 3/4 x 16 Ga.
79	532125398	Bolt Hex
80	874760508	Bolt Hex Hd. 5/16-18unc x 1/2
81	532128861	Nut Flange 1/4-20 Starter Nut

NOTE: All component dimensions given in U.S. inches
1 inch = 25.4 mm

REPAIR PARTS

TRACTOR - MODEL NO. YTH150 (954140007B), PRODUCT NO. 954 14 00-07
MOWER DECK

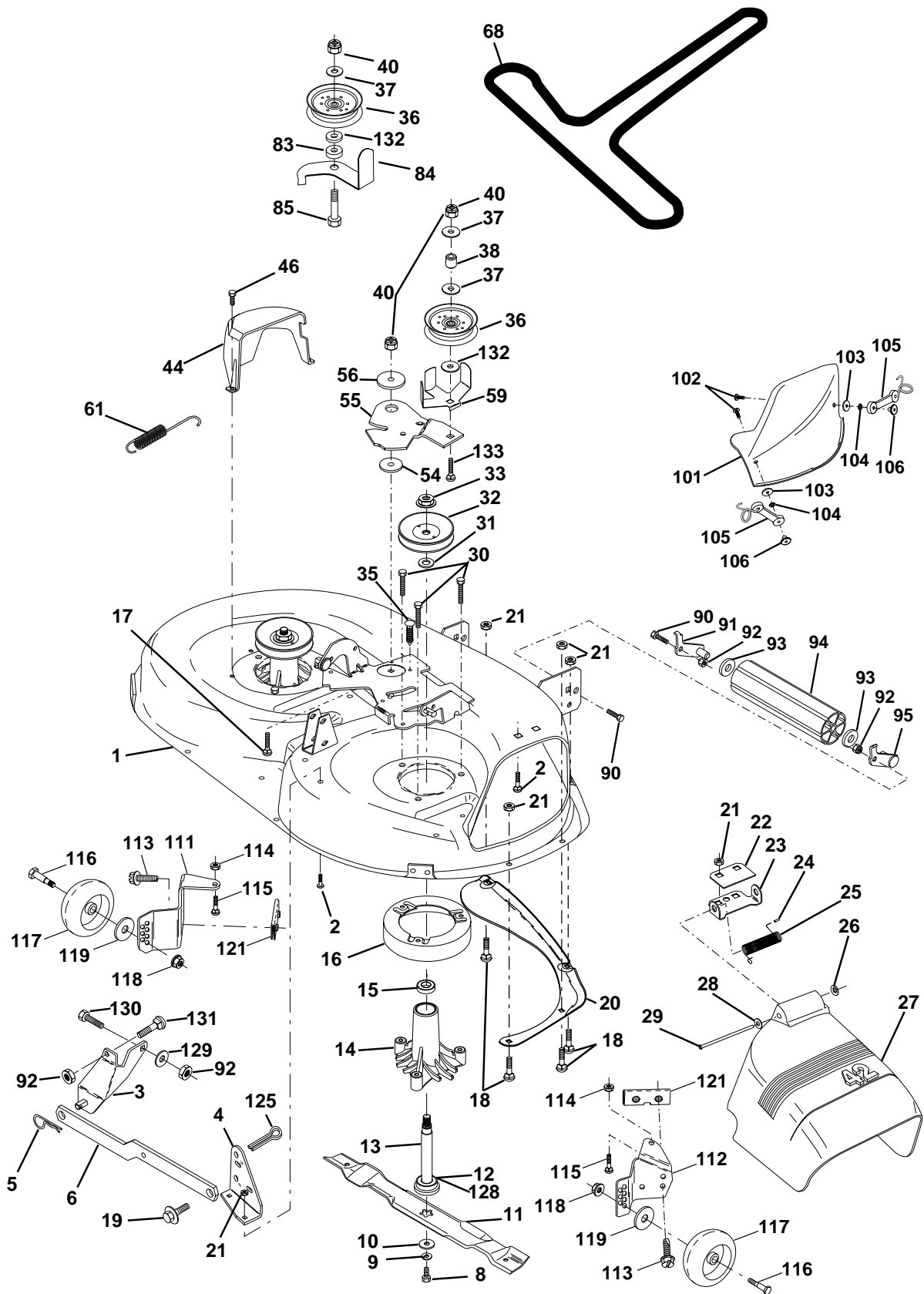

REPAIR PARTS

TRACTOR - MODEL NO. YTH150 (954140007B), PRODUCT NO. 954 14 00-07

MOWER DECK

KEY NO.	PART NO.	DESCRIPTION	KEY NO.	PART NO.	DESCRIPTION
1	532144393	Housing Asm Mower 42"94 T-Path	68	532144200	V-Belt Mower
2	872140506	Bolt Rdhd Sqnk 5/16-18unc X3/4	83	532120958	Washer Sintered
3	532138017	Bracket Asm Fr Sway Bar 38/42	84	532156084	Keeper 'Belt Idler
4	532138440	Bracket Asm Deck 42"sway Bar	85	872140618	Bolt Carriage 3/8-16 x 2-1/4 Gr.5
5	532124670	Retainer Spring	90	874760616	Bolt Fin Hex 3/8-16unc X 1
6	532130832	Arm Suspension Rear	91	532132274	Bracket Asm Noseroller LH
8	532850857	Bolt 3/8-24x1 25 Gr8 Patched	92	873800600	Nut Lock Hex w/ins. 3/8-16 UNC
9	810030600	Washer Lock Hvy 3/8 Unplated	93	819171416	Washer 17/32 X 7/8 X 16 Ga
10	532140296	Washer Hard Blade Mower Vented	94	532132264	Roller Nose 38 & 42
11	532134149	Blade Mower Mulching 42"	95	532132273	Bracket Asm Noseroller RH
12	532129895	Bearing Ball #6204 (Mandrel)	101	532136420	Cover Mulching 42" Blk
13	532137645	Shaft Asm W/lower Bearing	102	871161010	Screw
14	532128774	Housing Mandrel Vented(machd)	103	819061216	Washer #10
15	532110485	Bearing Ball Mandrel	104	810071000	Washer Lock #10
16	532140329	Stripper Round Mower	105	532130758	Latch Asm Bagger
17	872110618	Bolt Rdhd Sqnk 3/8-16 X 2-1/4	106	532125004	Nut Weld .327/.304 #10-24
18	872140505	Bolt Carr 5/16-18 X 5/8	111	532155197	Bracket Wheel Gauge Lh 42" Deck
19	532132827	Bolt Shoulder	112	532155198	Bracket Gauge Wheel Rh 42" Deck
20	532136888	Baffle Vortex 42	113	817490512	Screw Thdrol 5/16-18 x 3/4 TYT
21	873680500	Nut Crown Lock 5/16-18	114	873510500	Nut Keps 5/16 - 18 UNC
22	532134753	Stiffener Bracket 42"deck	115	872110504	Bolt Carriage 5/16 - Unc x 1/2
23	532131267	Bracket Deflector Mower 42"	116	532137644	Bolt Shld
24	532105304	Cap Sleeve 80x 112 Blk Mower	117	532133957	Wheel Gauge Donut
25	532123713	Spring Torsion Deflector 2 52	118	873930600	Nut Centerlock 3/8 - 16 UNC
26	532110452	Nut Push Phos & Oil	119	819121414	Washer 3/8 x 7/8 x 14 Ga.
27	532130968	Shield Deflector Mower 42" Blk	121	532143723	Bracket
28	819111016	Washer 11/32 X 5/8 X 16 Ga	125	876020816	Cotter Pin
29	532131491	Rod Hinge 42"6 75 Wlg	128	532153390	Washer Felt
30	532157722	Screw Thdrol Washer Head	129	819131312	Washer 13/32 x 13/16 x 12 Ga.
31	532129963	Washer Spacer Mower Vented	130	874780616	Bolt Fin Hex 3/8-16unc x 1 Gr. 5
32	532153535	Pulley Mandrel 42"	131	872140608	Bolt Rdhd Sqnk 3/8-16 UNC
33	532137266	Nut 9/16top Lock Flng Cntr	132	819132203	Washer 13/32 x 1-3/8 x 3 Ga.
35	532133835	Fastner Christmas Tree	133	872110622	Bolt RDHD 3/8-16 UNC x 2-3/4 Gr.5
36	532131494	Pulley Idler Flat 3 060	--	532145452	Deck Serv 42" Elec Vent (Standard Deck - Order Nose Roller, Gauge Wheel and Mulcher Plate components separately Key Nos. 90-95, 101-106 and 111-121)
37	819131316	Washer 13/32 X 13/16 X 16 Ga	--	532130794	Mandrel Assembly (Includes Key Numbers 8-10, 12-15, 31 and 33)
38	532132823	Spacer Spring Stop Idler			
40	873680600	Nut Lock 3/8-16 Unc			
44	532140088	Guard Mandrel LH Black			
46	532137729	Screw Thdrol 1/4-20x5/8			
54	532133943	Washer Hardened			
55	532140084	Arm Idler 42"mower LT/YT			
56	532122052	Spacer Retainer Pm Mower			
59	532141043	Guard, Belt			
61	532131950	Spring Ext. Elect			

NOTE: All component dimensions given in U.S. inches
1 inch = 25.4 mm

REPAIR PARTS

TRACTOR - MODEL NO. YTH150 (954140007B), PRODUCT NO. 954 14 00-07

MOWER LIFT

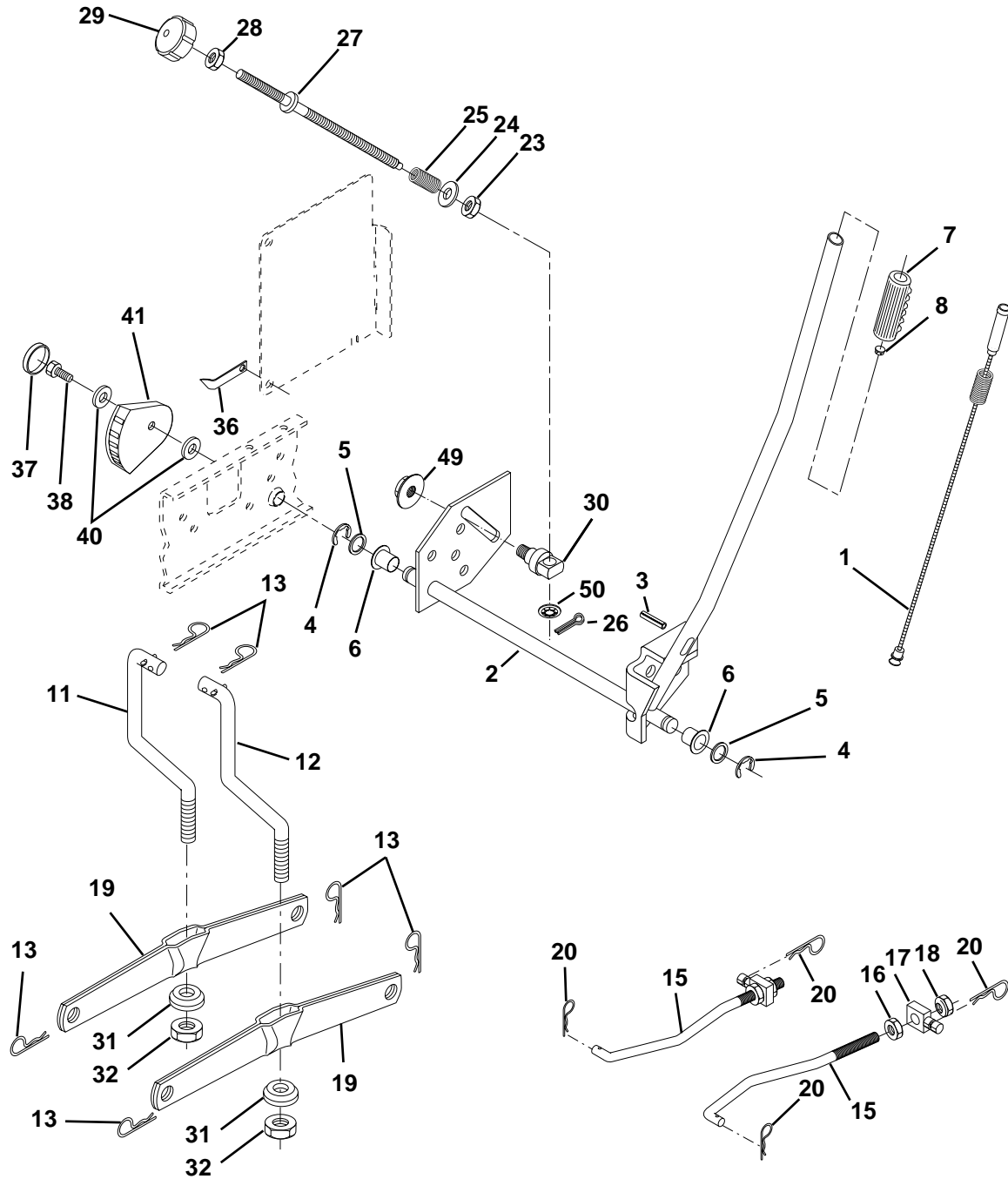

REPAIR PARTS

TRACTOR - MODEL NO. YTH150 (954140007B), PRODUCT NO. 954 14 00-07

MOWER LIFT

KEY NO.	PART NO.	DESCRIPTION
1	532159460	Wire Asm Inner W/plunger
2	532159471	Shaft Asm Lift RH w/Inf
3	532105767	Pin Groove 1 500 Zinc
4	812000002	E Ring #5133-62
5	819211621	Washer 21/32 X 1 X 21 Ga
6	532120183	Bearing Nylon Blk 629 Id
7	532125631	Grip Handle Fluted Blk
8	532124526	Button Plunger Black
11	532139865	Link Lift LH Fixed Length
12	532139866	Link Lift RH Fixed Length
13	532124670	Retainer Spring
15	532127218	Link Front
16	873350800	Nut Jam Hex 1/2-13 Unc
17	532130171	Trunnion Blk Zinc
18	873800800	Nut Lock W/wsh 1/2-13unc
19	532139868	Arm Suspension Rear
20	532124660	Retainer Spring
23	532110807	Nut Special
24	819131016	Washer 13/32 X 5/8 X 16 Ga
25	532124874	Spring 2-1/8"
26	876020308	Pin Cotter 3/32 X 1/2
27	532126971	Rod Adj Lift Zinc 7.49 Wrk Lg
28	873350600	Nut Hex Jam 3/8-16 Unc
29	532138057	Knob Inf 3/8-16 Unc Blk W/sym
30	532150233	Trunnion Infin Height
31	532140302	Bearing Pvt Lift Spherical
32	873540600	Nut Crownlock 3/8 - 24
36	532155097	Pointer Height Indicator
37	532123935	Plug Hole Blk 1.485/1.515 Dia.
38	817490512	Screw Thdrol 5/16-18 x 3/4
40	819112410	Washer 11/32 x 1-1/2 10 Ga.
41	532155098	Indicator Height STLT
49	532145212	Nut Hex Flange Lock
50	532110452	Nut Phos & Oil

NOTE: All component dimensions given in U.S. inches
1 inch = 25.4 mm

REPAIR PARTS

TRACTOR - MODEL NO. YTH150 (954140007B), PRODUCT NO. 954 14 00-07
PEERLESS TRANSAXLE - MODEL NUMBER 205-026B

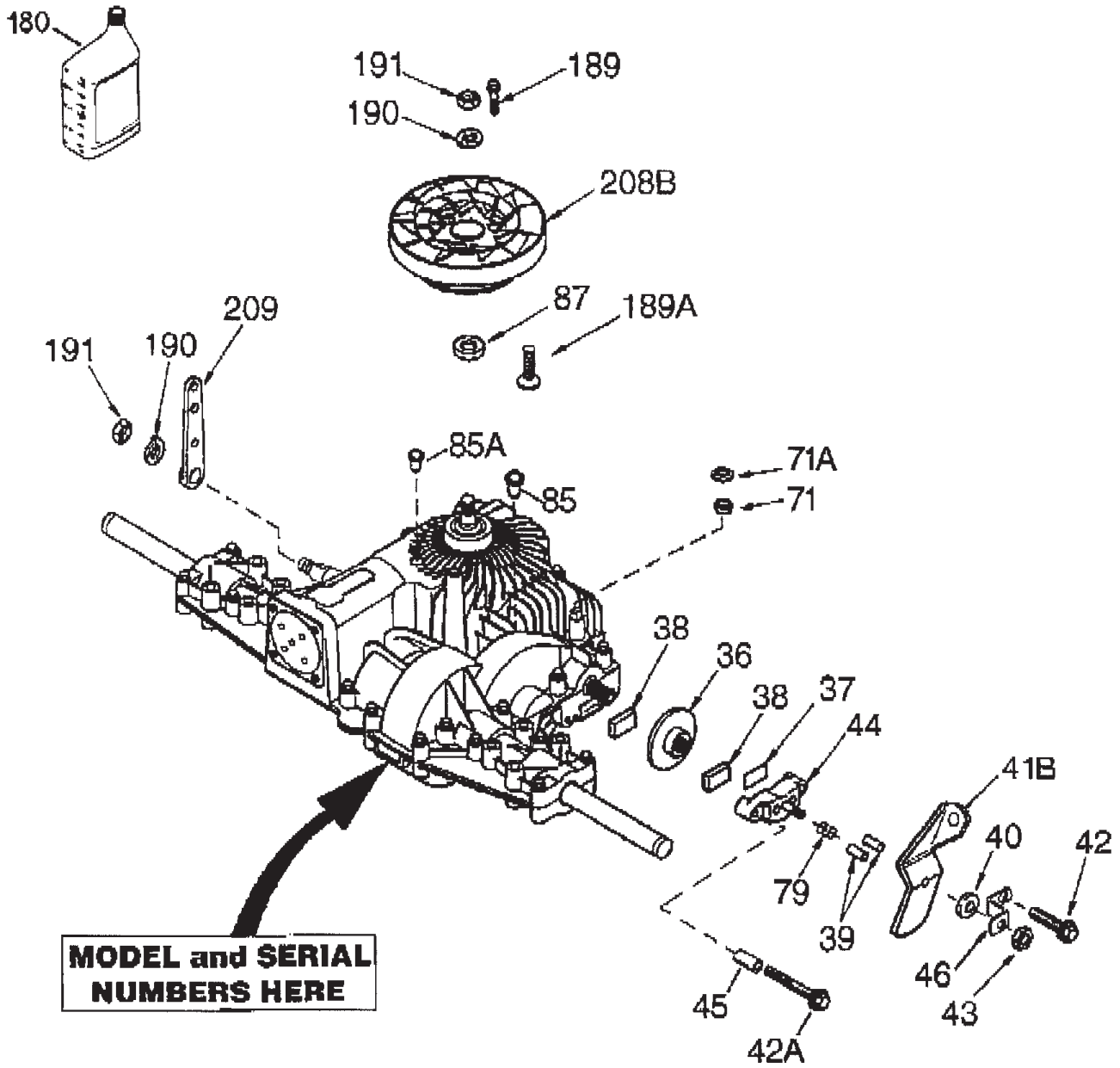

REPAIR PARTS

TRACTOR - MODEL NO. YTH150 (954140007B), PRODUCT NO. 954 14 00-07

PEERLESS TRANSAXLE - MODEL NUMBER 205-026B

REF NO.	PART NO.	DESCRIPTION
36	790075	Brake Disc
37	790007	Brake Pad Plate
38	799021	Brake Pad (pkg of 2)
39	786026	Dowel Pin
40	792076A	Flat Washer
41	790085	Brake Lever
42	792073	Screw, 1/4-20 x 1-1/4"
42A	792085A	Screw, 1/4-20 x 2-1/4"
43	792075	Locknut, 5/16-24
44	790025	Brake Pad Holder
45	786066	Spacer
46	790086	Brake Lever Bracket
71	788069	Square Cut Ring
71A	792162	Pushnut, 9/16"
79	792144	Spring
87	788035	Oil Seal, 5/8"
180	730229A	Gear Oil 80W90
189	792168	Drive Screw #6 x 1/2"
189A	792169	Screw, 10-32 x 1/2"
190	792150	Lockwasher
191	792151	Nut, 7/16-20
208B	798025	Fan/Coupling (Incl. 189 & 189A)
209	798024	Control Lever

Parts must be ordered from Tecumseh Products Co.

NOTE: All component dimensions given in U.S. inches
1 inch = 25.4 mm