

225H60/H75

Operator's Manual (Carb, EPA)



Read through the Operator's Manual carefully and understand the content before using the machine.

SYMBOL EXPLANATION

Symbols



WARNING! The hedge trimmer can be dangerous!
Careless or incorrect use can result in serious, even fatal injury.



Read through the Operator's Manual carefully and understand the content before using the hedge trimmer.



Always use

- Ear protection
- Approved eye protection



- This product is in accordance with applicable CE directives.



- Always wear approved protective gloves.



- Cutting tool. Do not touch the tool without first switching off the engine.

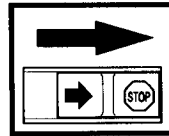

Checks and/or maintenance should be carried out with the engine switched off, with the stop switch in the STOP position.

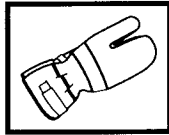

Always use approved protective gloves.

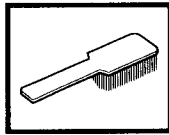

Regular cleaning required.

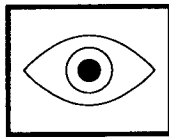

Ocular control.



Approved eye protection must always be used.

CONTENTS

Before using a new machine

- Read the Operator's Manual carefully.
- Start the machine and check the carburettor settings. See pages 8, 13 and 14-15.

IMPORTANT! A too lean carburettor adjustment significantly increases the risk of an engine breakdown. Insufficient care of the air filter will cause deposits on the spark plug resulting in starting difficulties.

Maintenance, replacement, or repair of the emission control devices and systems may be performed by any nonroad engine repair establishment or individual.



WARNING!

Under no circumstances may the design of the machine be modified without the permission of the manufacturer. Always use genuine accessories. Non-authorized modifications and/or accessories can result in serious personal injury or the death of the operator or others.

Your warranty does not cover damage or liability caused by the use of non-authorized accessories or replacement parts.



WARNING

The engine exhaust from this product contains chemicals known to the State of California to cause cancer, birth defects or other reproductive harm.

List of contents

SYMBOL EXPLANATION

Symbols 2

CONTENTS

Before using a new machine 3

List of contents 3

SAFETY INSTRUCTIONS

Personal protective equipment 4

The machine's protective equipment 4

Control, maintenance and service of the hedge trimmer's protective equipment 6

General safety instructions 8

General working instructions for hedge trimmer 9

WHAT IS WHAT?

What is what on the hedge trimmer? 11

FUEL HANDLING

Fuel mixture 12

Fuelling 12

START AND STOP

Control before starting 13

Start and stop 13

MAINTENANCE

Carburettor 14

Muffler 16

Cooling system 16

Air filter 17

Spark plug 17

Gearbox 17

Lubrication 17

Maintenance schedule 18

TECHNICAL DATA

H60 19

H75 19

FEDERAL AND CALIFORNIA EMISSION CONTROL WARRANTY STATEMENT

..... 20

SAFETY INSTRUCTIONS

Personal protective equipment

IMPORTANT INFORMATION

- **Incorrect or careless use of a hedge trimmer can turn it into a dangerous tool that can cause serious or even fatal injury. It is extremely important that you read and understand this manual.**
- **When using a hedge trimmer, protective equipment approved by the appropriate authorities must be used. Personal protective equipment does not eliminate the risk of accidents, however, it can reduce the effects of an injury in the event of an accident. Ask your dealer for help when choosing protective equipment.**

GLOVES

Gloves should be worn when necessary, e.g., when inspecting, cleaning or assembling cutting equipment.

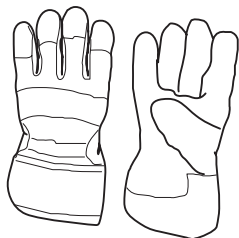

EAR PROTECTION

Ear protection offering sufficient dampening effect should be used.

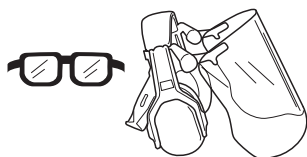

EYE PROTECTION

Blows from branches or objects thrown by the moving blades can damage the eyes.



BOOTS

Use anti-slip and stable boots.



CLOTHING

Wear clothes made of a strong fabric and avoid loose clothing that can catch on shrubs and branches.

FIRST AID KIT

A first aid kit should be close at hand.



The machine's protective equipment

This section describes the hedge trimmer's protective equipment, its function and how checks and maintenance are carried out to ensure that it operates correctly. (See the chapter "What is what" to locate where this equipment is positioned on your machine.)



WARNING!

Never use a hedge trimmer with defective protective equipment. Follow the control, maintenance and service instructions described in this section.

1. Throttle trigger lock

The throttle trigger lock is designed to prevent the throttle from accidentally being engaged. The trigger (A) can only be pressed in, if the lock (B) is held in (= the operator holding the handle). When the grip on the handle is released the throttle and the throttle trigger lock return to their original positions. This takes place via two independent return spring systems. This means that the throttle is automatically locked in the idling position.

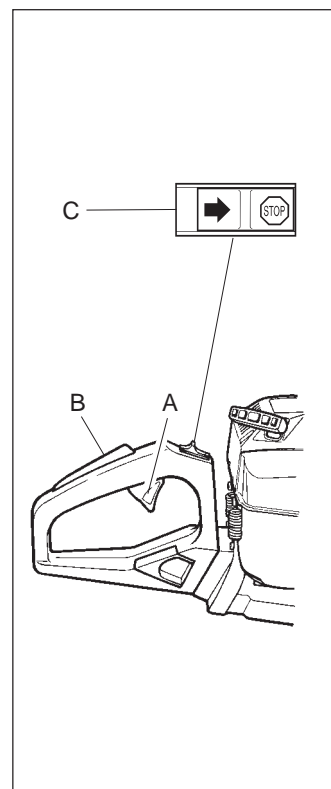

2. Stop switch

The stop switch (C) should be used to stop the engine.

3. Hand guard

The hand guard (D) prevents the operator's hands from coming into contact with the blades. For example, if the operator should lose his grip on the front handle.

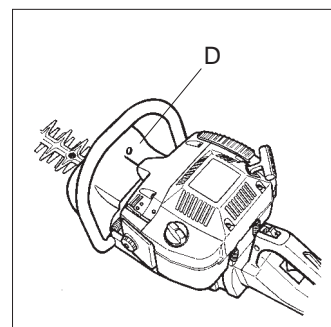

SAFETY INSTRUCTIONS

4. Vibration damping system

The hedge trimmer is equipped with a vibration damping system, which is designed to give as vibration-free and comfortable use as possible.

The hedge trimmer's vibration damping system reduces the transfer of vibrations between the engine unit/blades and the hedge trimmer's handles. The engine body including the blades is suspended on the handlebar system via a four springs.

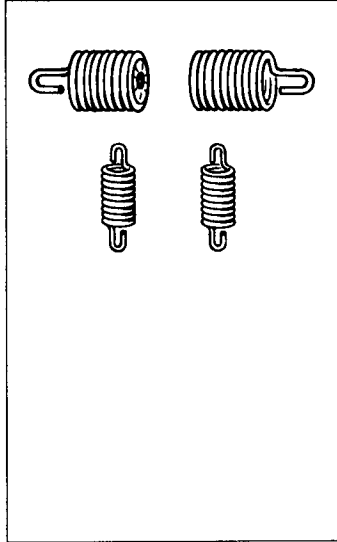

WARNING!

Over exposure to vibrations can result in blood-vessel or nerve injury to persons suffering with blood circulation problems. Seek medical attention if you experience physical symptoms that can be related to over exposure to vibrations. Examples of such symptoms are "numbness", lack of feeling, "tickling", "prickling", "pain", lack of or a reduction in normal strength, changes in the colour of the skin or its surfaces. These symptoms normally appear in the fingers, hands or wrists.

5. Muffler

The muffler is designed to give the lowest possible noise level and to direct the engine's exhaust fumes away from the operator. Muffler fitted with catalytic converter is also designed to reduce harmful exhaust components.

In warm and dry climates the risk of fire is obvious. To minimise the risk of fire the muffler is fitted with a spark arrest screen.

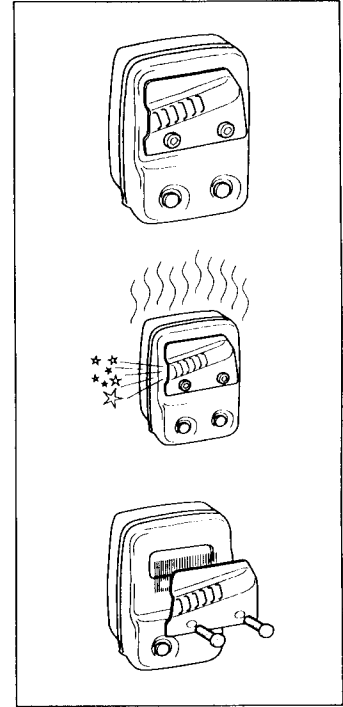

It is extremely important that the instructions for checking, maintaining and servicing the muffler are followed. (see the section "Control, maintenance and service of the hedge trimmer's protective equipment").



WARNING!

The exhaust fumes from the engine are hot and may contain sparks which can start a fire. Never start the machine indoors or near combustible material!



WARNING!

Mufflers fitted with catalytic converters become extremely hot during use and after stopping. This also applies at idling speeds. Contact can result in burns to the skin. Be observant to the risk of fire!

6. Blade guard

The blade guard (A) is intended to protect against any part of the body coming into contact with the blades (B).

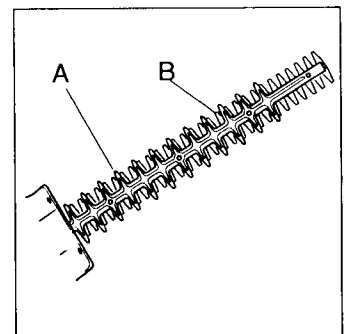

SAFETY INSTRUCTIONS

Control, maintenance and service of the hedge trimmer's protective equipment

IMPORTANT INFORMATION

- All service and repairs to the hedge trimmer require special training.
- This applies especially to the hedge trimmer's protective equipment. If the hedge trimmer does not meet any of the controls listed below you should contact a service workshop authorised by Husqvarna.
- A purchase from one of Husqvarna's dealers guarantees professional repair and service. If the point of purchase of the hedge trimmer was not one of Husqvarna's dealers, please ask the salesman for details of the closest service workshop.



WARNING!
Never use a machine with defective safety equipment. The safety equipment should be maintained as described in this section. If your machine does not meet any of these controls you should contact your service workshop.



WARNING!
Always stop the engine before starting work on any part of the cutting equipment. This continues to rotate even after the throttle has been released. Ensure that the cutting equipment has stopped completely and remove the cable from the spark plug before you start to work on it.

1. Throttle trigger lock

- Check that the throttle is locked when the throttle trigger lock is not pressed in. That is the hedge trimmer runs at idling speed.
- Press in the throttle trigger lock and make sure it returns to its original position when released.
- Ensure that the throttle and throttle trigger lock move easily when pressed and released.
- See the section "Start". Start the hedge trimmer and apply full throttle. Release the throttle and check that the blades stop and remain at a standstill. If the blades rotate with the throttle in the idling position then the carburettor's idling setting must be checked. See chapter "Maintenance".

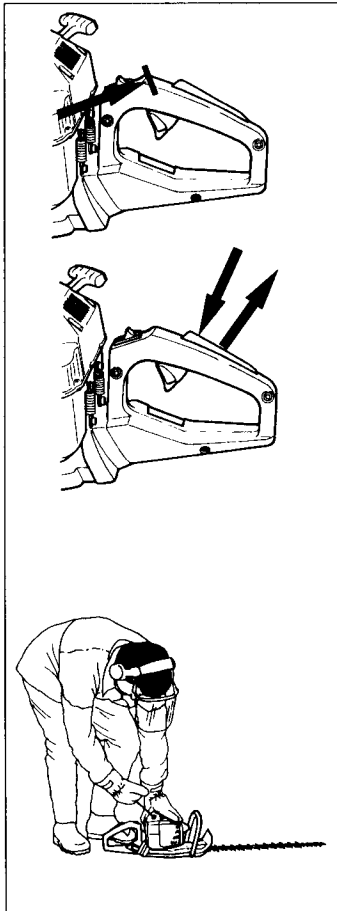

2. Stop switch

- Start the engine and make sure that the engine stops when the stop switch is moved to the stop position.

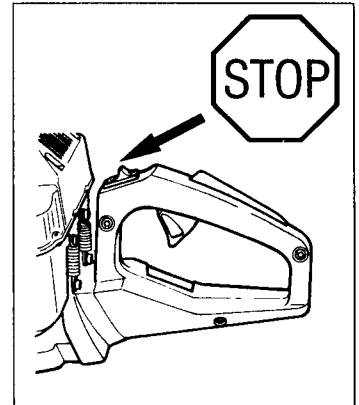

3. Hand guard

- Ensure that the blade guard is fitted correctly.
- Make sure the hand guard is not damaged in anyway.

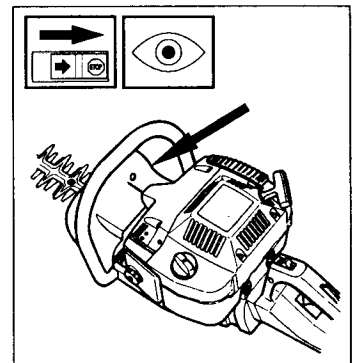

4. Vibration damping system

- Check regularly that the vibration damping element's springs are not damaged in anyway.
- Also check that the vibration damping element's springs are not distorted.

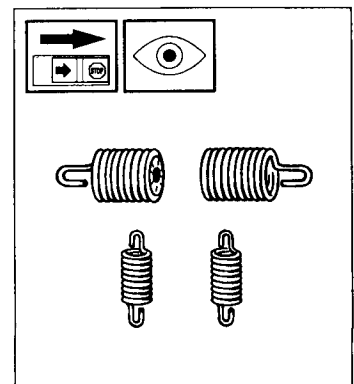

SAFETY INSTRUCTIONS

5. Muffler

- Never use the hedge trimmer if it has a defective muffler.
- Check regularly that the muffler is secure.
- The spark arrest screen should be cleaned regularly.

A blocked screen leads to the engine overheating with serious damage as a result.

Never use a muffler with a defective spark arrest screen.

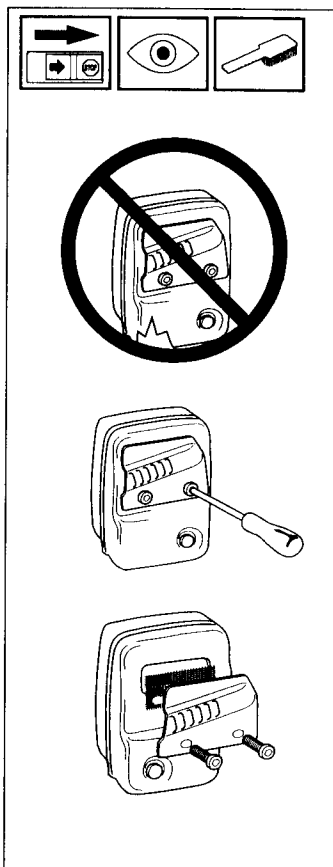

6. Blades

The contact pressure between the blades is adjusted automatically by the wave-formed plate (A). The four screws with nuts (B) should be tightened (20 Nm) without regard to the contact pressure.

The edges of the blade are too hard to be filed. Dull blades should be sharpened using a grinder.

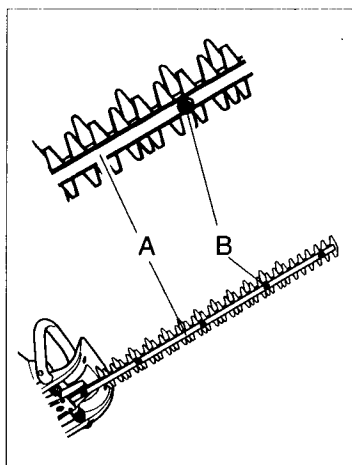

7. Blade guard

- Check that the blade guard is not damaged or distorted.
- Replace the blade guard if it is bent or damaged.

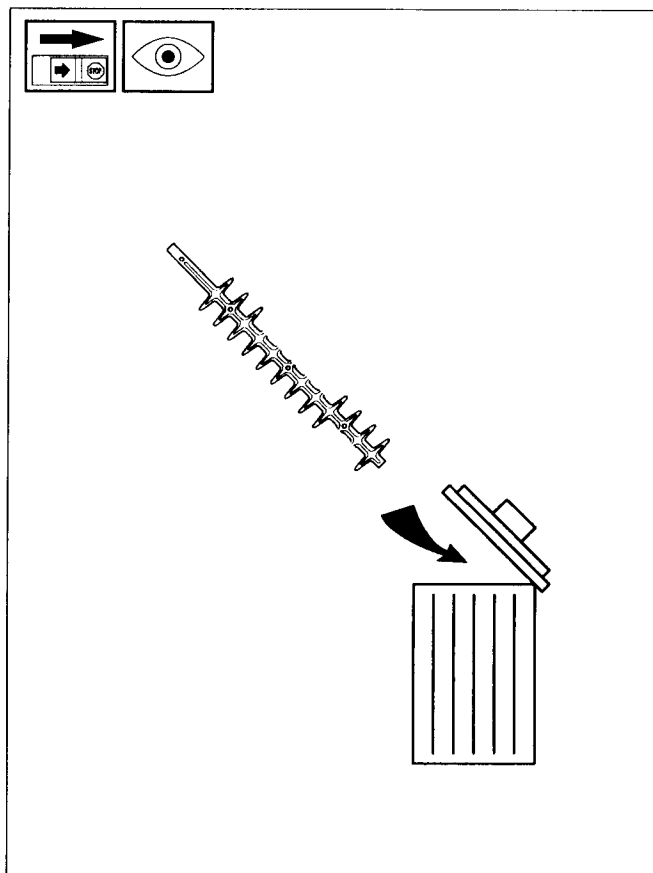

SAFETY INSTRUCTIONS

General safety instructions

IMPORTANT INFORMATION

- The machine is only designed for cutting branches and twigs.
- Never use the machine if you are tired, if you have consumed alcohol, or if you are taking medicines that can affect your sight, your judgement or the control of your body.
- Use personal protective equipment. See the section "Personal protective equipment".
- Never use a machine that has been modified so that it no longer corresponds with the original design.
- Never use a machine that is faulty. Follow the maintenance, control and service instructions in this Operator's Manual. Some maintenance and service actions should be carried out by trained and qualified specialists. See the chapter "Maintenance".



WARNING!
Faulty blades can increase the risk of accidents.

Start

- The gearbox and clutch drum must be fitted before the machine is started, otherwise the clutch can become loose and cause personal injury.
- Never start the machine indoors. Bear in mind the dangers of inhaling the engine's exhaust fumes.
- Observe your surroundings and make sure that there is no risk of people or animals coming into contact with the cutting equipment.
- Place the machine on the ground, make sure the blades are free from branches and stones. Press the machine body against the ground using your left hand (NOTE! Do not use your foot). Grip the starter handle with your right hand and pull the starter cord.

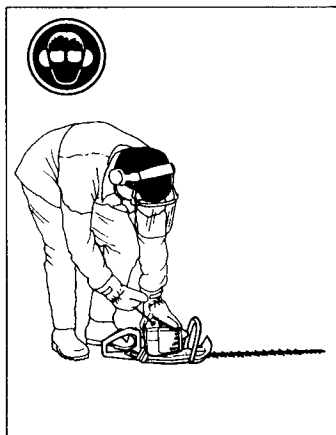

Fuel safety

- Never fill the machine while the engine is running. Always stop the engine and let it cool for a few minutes before refuelling.
- Provide good ventilation when filling or mixing fuel (petrol and 2-stroke oil).
- Move the machine at least 3 m from the filling position before starting.
- Never start the machine:
 - a) If you have spilt fuel on it. Wipe up all spillage.
 - b) If you have spilt fuel on yourself or your clothes. Change your clothes.
 - c) If there is a fuel leak. Make regular checks for leakage from the fuel cap and the fuel supply pipes.

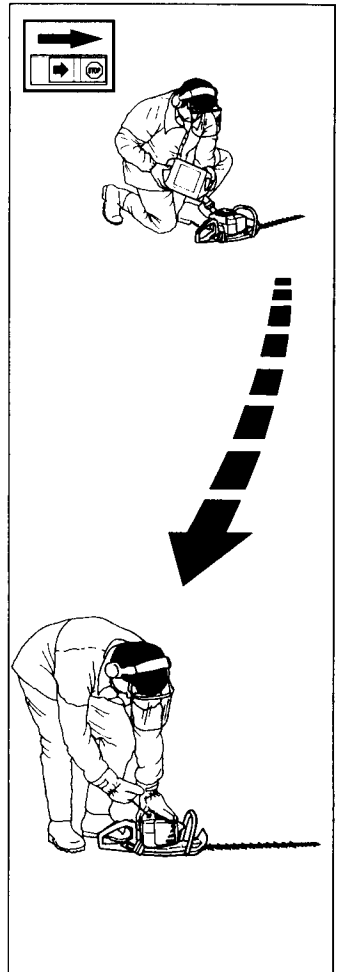

Transport and storage

- Store and transport the machine and fuel so that any leakage or fumes do not risk coming into contact with sparks or naked flames. For example, electric machines, electric motors, electrical switches/power switches, heaters or the like.
- When storing and transporting fuel, approved containers intended for this purpose must be used.
- When storing the machine for long periods the fuel tank must be emptied. Contact your local petrol station to find out how to dispose of excess fuel.
- The blades transport guard should always be fitted when transporting or storing the hedge trimmer.



WARNING!
Exercise great care when handling fuel. Bear in mind the risk of fire, explosions and inhaling fumes.

SAFETY INSTRUCTIONS

Safety instructions when using the hedge trimmer



WARNING!
The hedge trimmer can cause serious personal injury. Read the safety instructions carefully. Learn how to use the machine.



WARNING!
Cutting tool. Do not touch the tool without first switching off the engine.

NOTE! Read the Operator's Manual carefully before using the hedge trimmer.

Personal protection

- Always wear boots, and the other safety equipment described in the section "Personal protective equipment".
- Always wear working clothes and thick, long trousers.
- Never wear loose fitting clothes or jewellery
- Hair should be put up if longer than shoulder

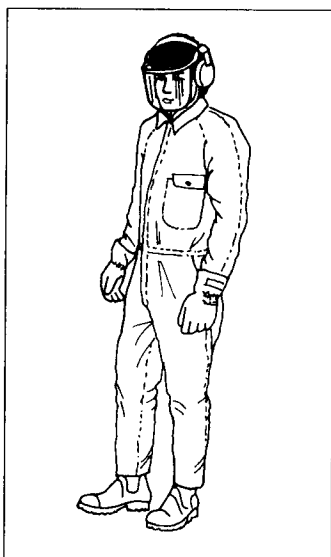

Protective instructions regarding the surroundings

- Never allow children to use the machine.
- Ensure no one comes within 15 metres while working.
- Never allow anyone to use the machine without first being absolutely sure that they understand the contents of the Operator's Manual.
- Never work on a ladder, stool or any other raised position that is not fully secured.

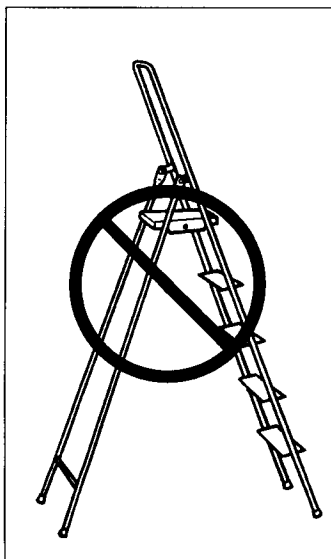

Protective instructions while working

- Always ensure you have a safe and firm working position.
- Always use both hands to hold the machine. Hold the machine on the right-hand side of the body.
- Make sure that your hands and feet cannot come into contact with the blades when the engine is running.

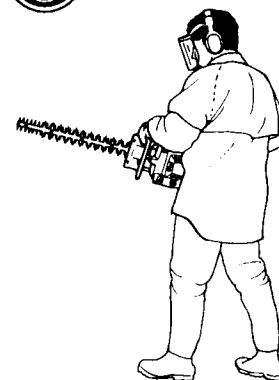

- When the engine is switched off, keep your hands and feet away from the blades until they have stopped.



- Do not cut too close to the ground. Stones and other objects can be thrown.
- If any object is hit or if vibrations occur stop the machine immediately. Remove the spark plug cable from the spark plug. Check that the machine is not damaged. Repair any damage.

SAFETY INSTRUCTIONS

Protective instructions when work is completed

- The transport guard should always be fitted to the blades when the machine is not in use.
- Ensure the blades have stopped and remove the spark plug cable from the spark plug before carrying out cleaning, repairs or an inspection.
- Always wear heavy duty gloves when repairing the blades. The blades are extremely sharp and can easily causes cuts.
- Store the machine out of reach from children.
- Only use original spare parts when carrying out repairs.

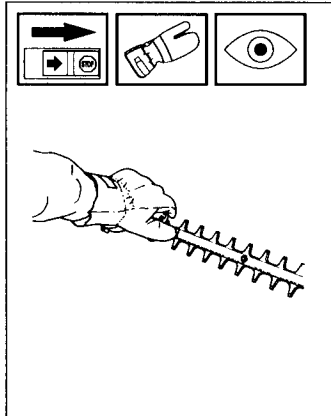

Basic working techniques

- The hedge trimmer's rear handle can be set in three positions by pulling out the catch. See figure. When the handle is adjusted the hedge trimmer should be idling or not running.
- While working the handle should always be facing upwards irrespective of how the hedge trimmer is directed.
- When trimming a hedge the engine should always be turned away from the hedge.
- The hedge trimmer should be held as close to the body as possible to get the best balance.
- Make sure that the tip does not touch the ground.
- Do not try to force the work, but move at a steady speed so that all the stems are cut evenly.

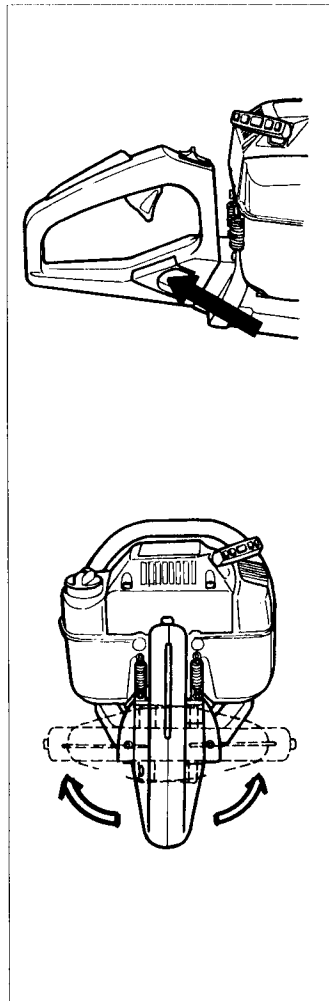

WHAT IS WHAT?

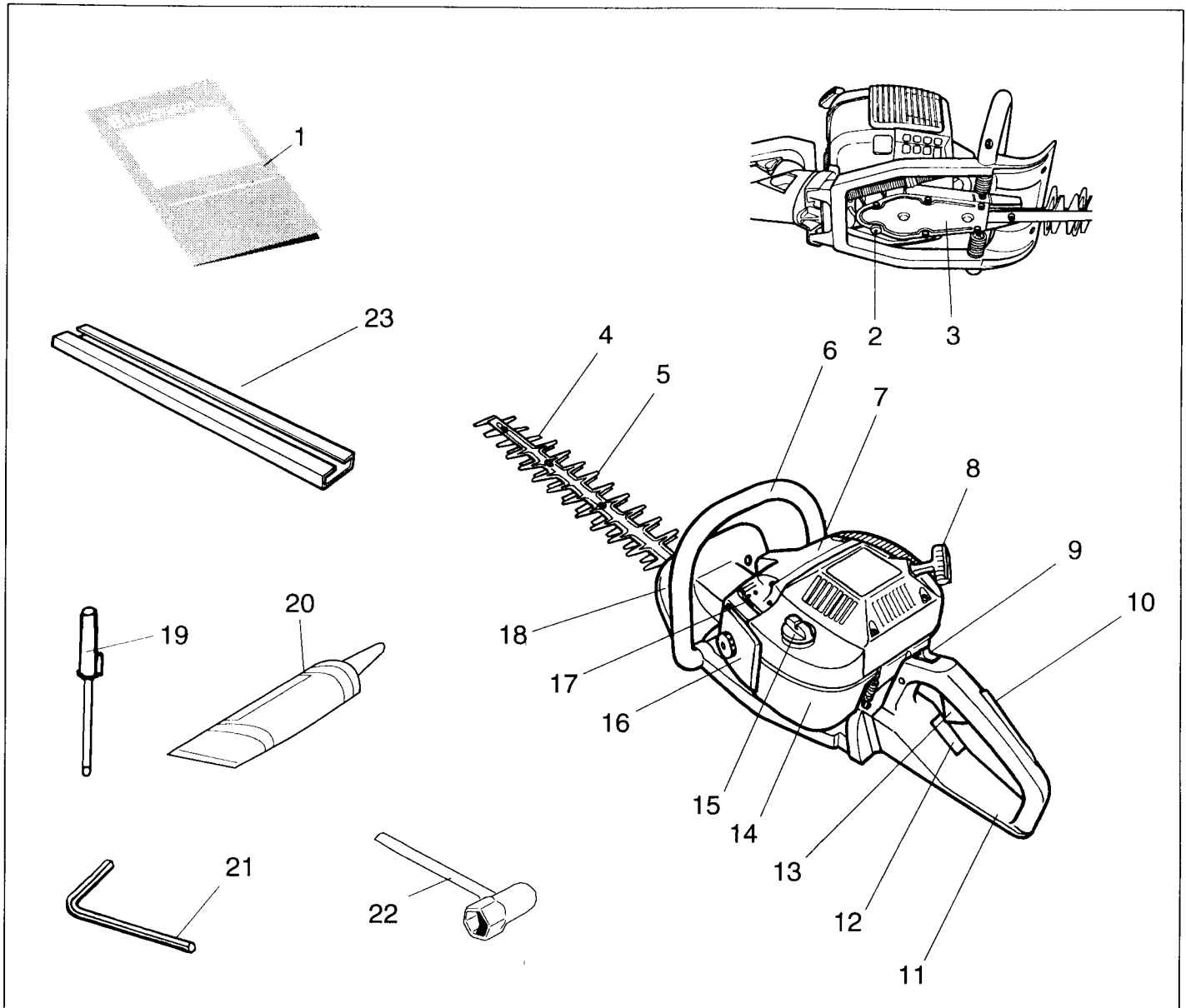

What is what on the hedge trimmer?

1. Operator's Manual
2. Grease filler cap
3. Gearbox
4. Blades
5. Blade guard
6. Loop handle
7. Cylinder cover
8. Starter handle
9. Stop switch
10. Throttle trigger lock
11. Adjustable handle
12. Lock for handle 11
13. Throttle trigger
14. Fuel tank
15. Fuel cap
16. Air filter cover
17. Choke
18. Hand guard
19. Carburettor screwdriver
20. Tube of grease
21. Allen key
22. Spark plug spanner
23. Blade cover (Transport)

FUEL HANDLING

Fuel

NOTE!

The hedge trimmer is fitted with a two-stroke engine and must always be run on a mixture of gasoline and two-stroke oil. To ensure the correct mixture proportions it is important to measure the quantity of oil accurately. When mixing small amounts of fuel small discrepancies in the amount of oil has a great bearing on the proportions of the fuel mixture.



WARNING!
Always provide good ventilation when handling fuel.

Gasoline

NOTE!

Always use high grade unleaded oil mixed gasoline (minimum 87 RON). Leaded fuel will destroy the catalytic converter and it will no longer serve its purpose.

- This engine is certified to operate on unleaded gasoline.
- The lowest recommended octane rating is 87. If you run the engine on lower octane rating than 87 so-called "knocking" can occur. This leads to an increased engine temperature, which can result in a serious engine breakdown.
- When working at continuous high revs a higher octane rating is recommended.

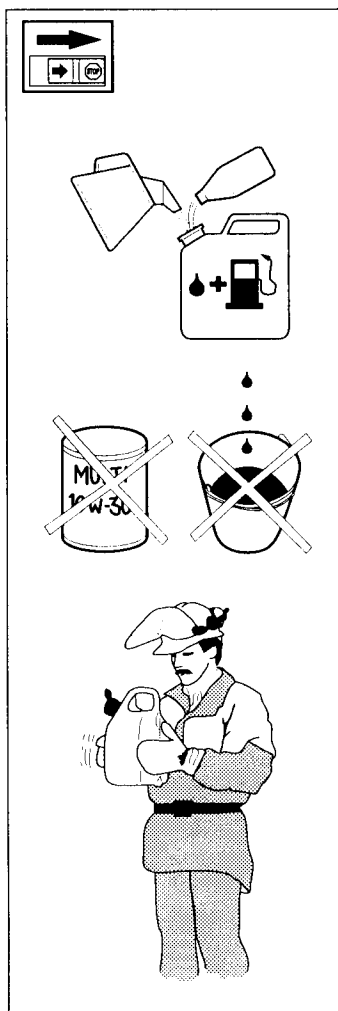

Two-stroke oil

- For the best results use HUSQVARNA two-stroke oil, which has been specially developed for HUSQVARNA's small, two-stroke engines. Mixing ratio 1:50 (2%).
- Never use two-stroke oil intended for water cooled outboard motors, so-called outboard motor oil.
- Never use oil intended for four-stroke engines.

Mixture

- Always mix gasoline and oil in a clean container intended for fuel.
- Always start by filling half the quantity of gasoline required. Then add the entire oil quantity. Mix (shake) the fuel mixture. Fill the remaining quantity of gasoline.
- Mix (shake) the fuel mixture carefully before filling in the machine's fuel tank.
- Do not mix more than max. one month's supply of fuel.
- If the hedge trimmer is not used for a long period of time, the fuel tank should be emptied and cleaned.
- This engine is certified to operate on unleaded gasoline.



WARNING!
The catalytic converter muffler gets very hot during and after use. This also applies during idling. Be aware of the fire hazard, especially when handling the saw near flammable substances or vapours.

Fuelling



WARNING!
The following precautions reduce the risk of fire:
Do not smoke or place any sources of heat in the vicinity of the fuel.
Never refuel when the engine is running.
Switch off the engine and allow it to cool for a few minutes before filling.
Open the fuel cap slowly when fuelling so that any over pressure is released slowly.
Tighten the fuel cap carefully after refuelling.
Always move the hedge trimmer about 3 m from the fuelling place before starting.

- Clean around the fuel cap. Contamination in the tank can disrupt operations.
- Ensure that the fuel is well mixed by shaking the container before filling the tank.

Gasolin Lit.	Oil Lit.
	2% (1:50)
5	0,10
10	0,20
15	0,30
20	0,40
US gallon	US fl. oz.
	2% (1:50)
1	2 1/2
2 1/2	6 1/2
5	12 7/8

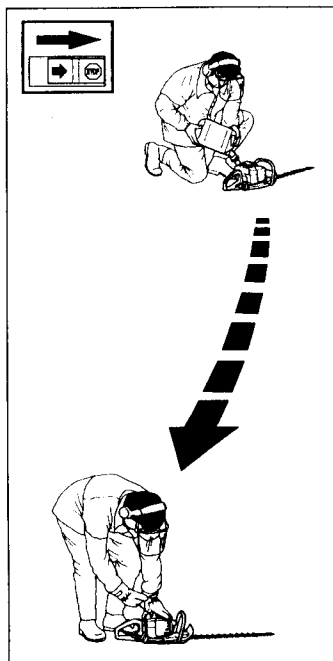

START AND STOP

Control before starting

- Inspect the working area. Remove objects that can be thrown.
- Check the blades. Never use blades that are dull, cracked or damaged.
- Check that the hedge trimmer is in full working order. Check that all nuts and bolts are tightened correctly.
- Make sure the gearbox is lubricated correctly. See the section "Lubricating the blades".
- Ensure the blades always stop when the engine is idling.
- Only use the machine for what it is intended for.
- Ensure that the handle and safety functions are in order. Never use a machine that lacks a part or has been modified outside of the specifications.

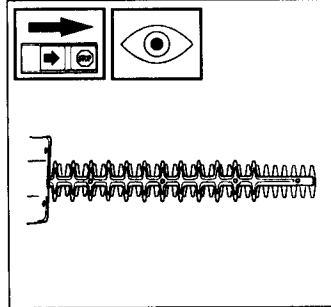

Start and stop

Start



WARNING!

The gearbox and clutch drum must be fitted before the machine is started, otherwise the clutch can become loose and cause personal injury.

Always move the hedge trimmer about 3 metres from the filling position before starting. Place the machine on a flat surface. Bear in mind that the blades start to move when the engine is started. Make sure the blades cannot come into contact with any object. Make sure that no unauthorised persons are in the working area, otherwise there is a risk of serious personal injury.

Cold engine

IGNITION:

Set the stop switch to the start position.

CHOKE:

Set the choke control in the choke position (A).

The choke position is also the automatic start throttle position

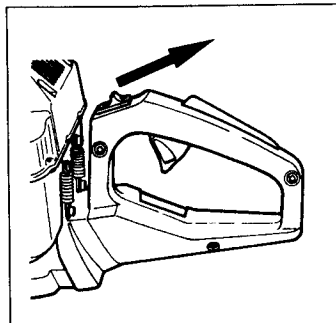

Warm engine

IGNITION:

Set the stop switch to the start position.

CHOKE:

Set the choke control in the choke position and then back again to its original position (B)

In this way only the start throttle is applied with no choke.

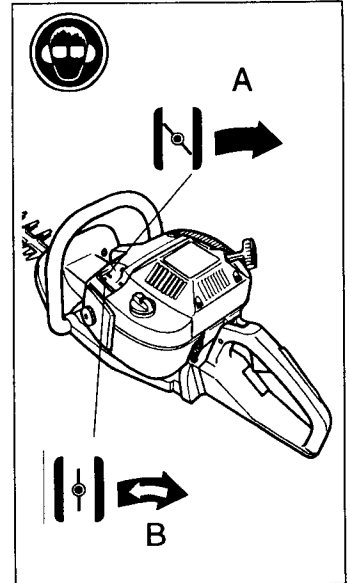

Press the machine body against the ground using your left hand (NOTE! Do not use your foot). Grip the starter handle with your right hand and slowly pull the starter cord out until you feel some resistance, (the starter hooks grip) now quickly and powerfully pull the cord.

Immediately press the choke control in when the engine fires and repeat until the engine starts. When the engine starts, quickly apply full throttle and the start throttle will automatically disengage.

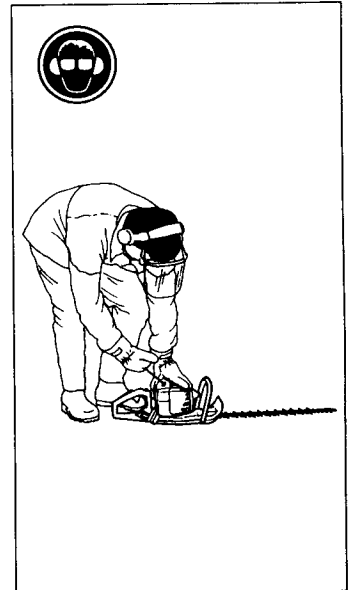

NOTE! Do not pull the starter cord out completely and do not release the starter cord from the fully extended position. This can damage the hedge trimmer.

Stop

The engine is stopped by switching the ignition off using the stop switch.

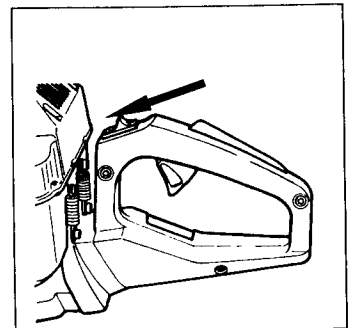

Carburettor

Your Husqvarna product has been designed and manufactured to specifications that reduce harmful emissions.

After your unit has been run 8-10 tanks of fuel the engine has broken in. To ensure that your unit is at peak performance and producing the least amount of harmful emissions after break in, have your authorized servicing dealer, who has a revolution counter at his disposal, to adjust your carburettor for optimum operating conditions.



WARNING!
The blades must be fitted before the hedge trimmer is started, otherwise the clutch can become loose and cause personal injury.

Operation

- The carburettor governs the engine's speed via the throttle. Air/fuel is mixed in the carburettor. The air/fuel mixture is adjustable. To take advantage of the engine's optimal output the adjustment must be correct.
- The setting of the carburettor means that the engine is adapted to local conditions, for example, the climate, altitude, petrol and the type of 2-stroke oil.
- The carburettor is equipped with three adjustment possibilities:
H = High speed needle
L = Low speed needle
T = Idle speed adjuster screw
- The fuel quantity in relation to the air flow permitted by the throttle opening is adjusted using the L and H-needles. Turning the needles clockwise gives a leaner fuel mixture (less fuel) and turning them anti-clockwise gives a richer fuel mixture (more fuel). A leaner mixture gives high revs while a richer mixture give less revs.
- The T-screw regulates the position of the throttle while the engine is idling. Turning the screw clockwise gives a higher idling speed while turning it anti-clockwise gives a lower idling speed.

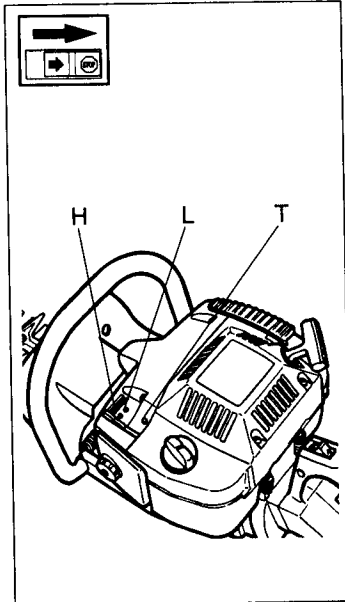

Basic setting

- The carburettor is set to its basic setting when test run at the factory. The basic setting is richer than the optimal setting and should be kept during the machine's first working hours. Thereafter the carburettor should be finely adjusted. Fine adjustment should be carried out by a skilled technician.

NOTE! If the cutting attachment rotates/moves while the engine is idling the T-screw should be turned anti-clockwise until the cutting attachment stops.

Recommended idling speed is 2.700 rpm.

Recommended max. speed 11 000-12 000 rpm.



WARNING!
If the idling speed cannot be adjusted so that the cutting attachment stops, contact your service workshop. Do not use the machine until it has been correctly adjusted or repaired.

Fine adjustment

- When the machine has been "run-in" the carburettor should be finely adjusted. The fine adjustment should be carried out by qualified person. First adjust the L-jet, then the idling screw T and then the H-jet.

Conditions

- Before any adjustments are made the airfilter should be clean and the airfilter cover fitted. Adjusting the carburettor while a dirty airfilter is in use will result in a leaner mixture when the filter is finally cleaned. This can give rise to serious engine damage.
- Carefully turn the L and H needle to the mid point between fully turned in and fully turned out.
- Do not attempt to adjust the needles beyond the stops as damage can occur.
- Now start the machine according to the starting instructions and run it warm for 10 minutes.

NOTE! If the cutting attachment rotates/moves the T screw should be turned anti-clockwise until the cutting attachment stops.

Low speed needle L

Try to find the highest idling speed, turning the low speed needle L clockwise respectively counter-clockwise. When the highest speed has been found, turn the low speed needle L 1/4 turn counter-clockwise.

NOTE! If the cutting attachment rotates/moves in the idling position, turn the idling speed screw T counter-clockwise until the cutting attachment stops.

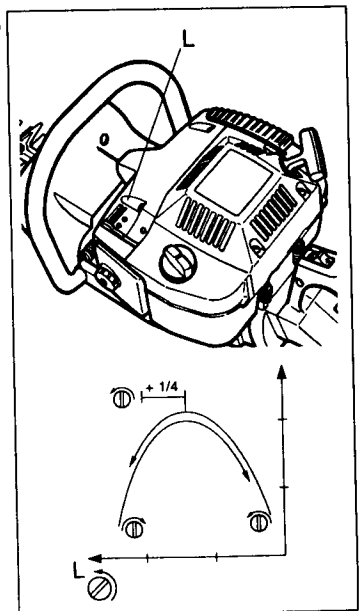

Final setting of the idling speed T

Adjust the idling speed with the screw T, if it is necessary to readjust. First turn the idle speed adjusting screw T clockwise until the cutting attachment starts to rotate/move.

Then turn, counter-clockwise until the cutting attachment stops. A correctly adjusted idle speed setting occurs when the engine runs smoothly in every position. It should also be good margin to the rpm when the cutting attachment starts to move.

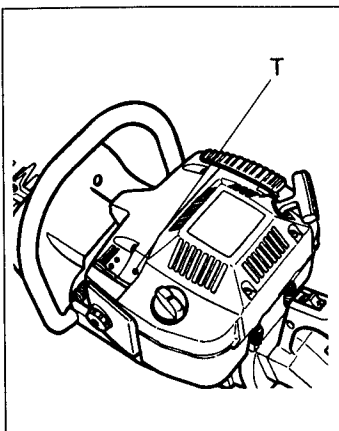

CAUTION! Contact your servicing dealer, if the idle speed setting cannot be adjusted so that the cutting attachment stops. Do not use the machine until it has been properly adjusted or repaired.

High speed needle H

The high speed needle H influences the power, speed, temperature and fuel consumption of the machine. A too lean adjusted high speed needle H (high speed needle H closed too much) gives overrevs and damages the engine. Do not let the machine run at full speed for more than 10 seconds. Turn the high speed needle counter-clockwise to end position.

Then slowly turn the high speed needle clockwise until you find the highest speed possible.

Thereafter turn the high speed needle counter-clockwise 1/8 turn. Carburettors with caps decrease the range of adjustment. The possible counter-clockwise turn might therefore be less than 1/8.

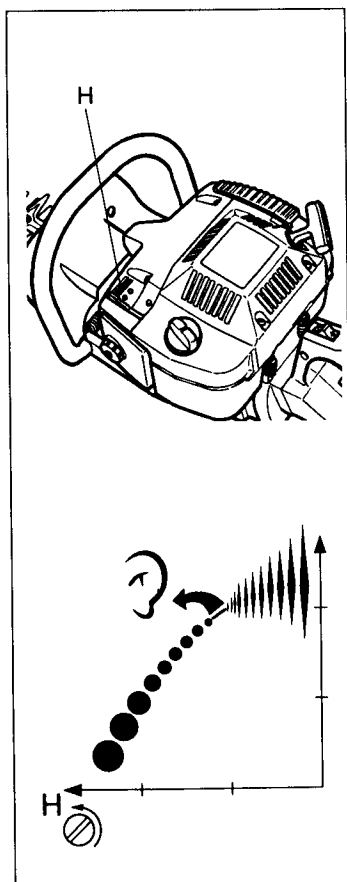

Correctly adjusted carburettor

A correctly adjusted carburettor means that the machine accelerates without hesitation. Furthermore, the cutting attachment must not rotate/move at idling. A too lean adjusted low speed needle L may cause starting difficulties and bad acceleration.

A too lean adjusted high speed needle H gives lower power = less capacity, bad acceleration and/or damage to the engine. A too rich adjustment of the two speed needles L and H gives acceleration problems or too low working speed.

NOTE! For optimum setting of the carburettor, contact a qualified servicing dealer who has a revolution counter at his disposal.

Muffler with catalytic converter

A muffler fitted with a catalytic converter reduces the extent of the following substances in the exhaust fumes:

- Hydrocarbons (HC). Some hydrocarbons in gasoline and the exhaust are carcinogenic.
- Nitric oxides (NO). Irritating for the breathing air-ways.
- Aldehydes. The most common formaldehyde, is carcinogenic and causes hypersensitiveness.

NOTE! The level of carbon monoxide is not reduced. This is an odourless and extremely poisonous substance. Therefore avoid exposure without good air circulation.

The muffler is also designed to dampen the noise level and to direct the exhaust fumes away from the user. The exhaust fumes are hot and can contain sparks, which can result in fire if the exhaust fumes are directed towards a dry or inflammable material. The muffler is fitted with a special spark arrest screen which should be cleaned at least once a week.

This is best done using a wire brush. If the screen is damaged in any way it should be replaced. If the screen is blocked this will result in engine overheating and damage to the cylinder and piston.

NOTE!

Never use a machine with a defective muffler. The muffler should be changed once a year for full performance.

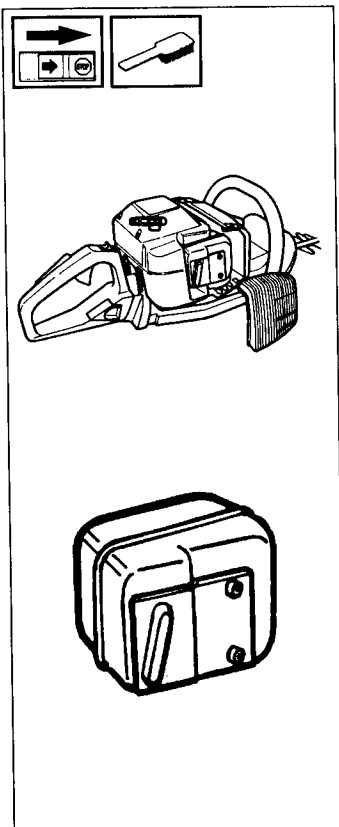

Cooling system

To maintain as low operating temperature as possible the engine is equipped with a cooling system.

The cooling system consists of:

1. An air intake on the starter unit.
2. Cooling fins on the flywheel.
3. Cooling fins on the cylinder
4. Cylinder cover (leads cold air onto the cylinder).

Clean the cooling system using a brush at least once a week, in difficult conditions more often.

A dirty or blocked cooling system leads to the engine overheating resulting in damage to the cylinder and piston.

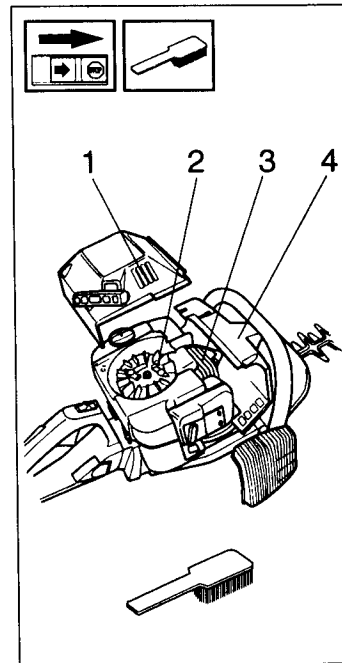

WARNING!
Mufflers fitted with catalytic converters become extremely hot during use and after stopping. This also applies at idling speeds. Contact can result in burns to the skin. Be observant to the risk of fire!



WARNING!
The coating on/in the catalytic element can be hazardous to health if consumed. Wear protective gloves when carrying out service work on the catalytic converter.

Air filter

The air filter (A) should be cleaned regularly removing dust and dirt to avoid:

- carburettor malfunction
- starting problems
- reduced engine power
- unnecessary wear to engine parts
- abnormal fuel consumption

Clean the filter after every 25 hours or more regularly if operating conditions are exceptionally dusty.

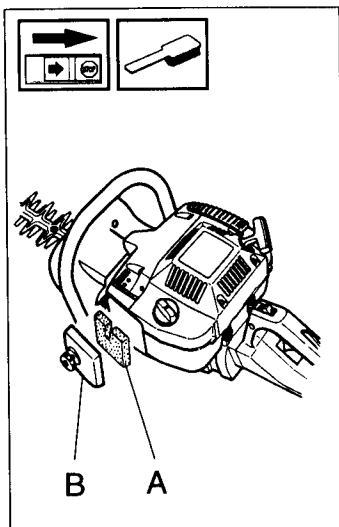

Cleaning the air filter

Dismantle the air filter cover (B) and remove the air filter. Wash in clean, warm soapy water. Ensure that the filter is dry before refitting.

An air filter used for a long period of time can never be cleaned completely. Therefore it is necessary to replace the filter from time to time with a new filter. A damaged air filter must always be replaced.

Spark plug

The condition of the spark plug is affected by:

- An incorrect carburettor setting.
- An incorrect fuel mixture (too much or faulty oil).
- A dirty air filter.

These factors cause deposits on the spark plug electrode that may result in malfunction or starting difficulties.

If the machine is low on power, difficult to start or runs poorly while idling always check the spark plug first before taking other action.

The spark plug is accessed from under the cylinder cover, which is removed by loosening the four bolts (A).

If the spark plug is dirty, clean it and at the same time check that the electrode gap is 0.5 mm. The spark plug should be changed after about one month of operation or earlier if necessary.

NOTE! Always use the recommended type of spark plug. An incorrect spark plug can damage the cylinder/piston.

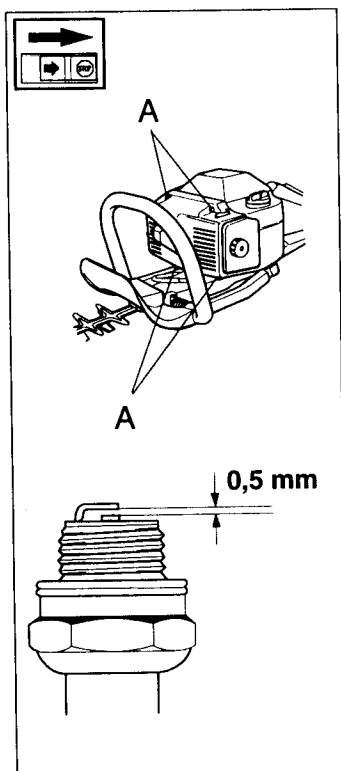

Gearbox

There is a grease plug on the gearbox (A). Remove the plug and insert a 4-5 cm string from the tube of grease supplied with the hedge trimmer. This should be carried out after approximately every 20 working hours. Use Husqvarna special grease, No 50 36 212-01.

The lubricant in the gearbox does not normally need to be replaced other than with repair.

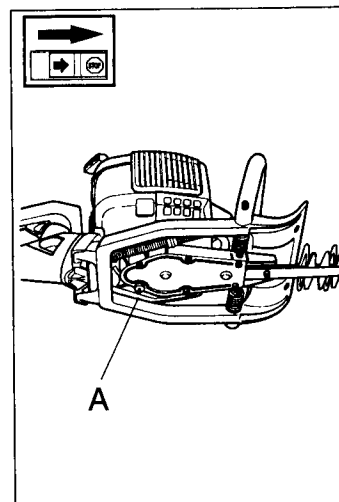

Lubrication

Lubricate blade arms using normal engine oil before use.

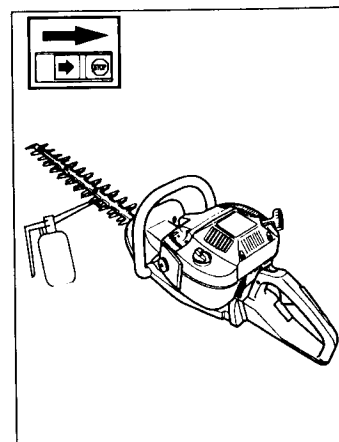

Maintenance schedule

Below you will find some general maintenance instructions.

Daily maintenance

- Check throttle trigger and throttle trigger lockout function.
- Check stop switch function.
- Check that blade does not move at idling.
- Clean the exterior of the machine.
- Check that the harness is undamaged.
- Check the blade guard for damage or cracks.
- Change the guard in case of impacts or cracks.
- Check that the blade is properly centred, sharp, and without cracks.
- Check the hand guard for cracks and chips or damage.
Replace if necessary.
- Check that the blade screws are sufficiently tightened.
- Make sure that the blade transport guard is undamaged and that it can be securely fitted.
- Check that nuts and screws are sufficiently tightened.

Weekly maintenance

- Check the starter, especially cord and return spring.
- Make sure that the vibration damping elements are not damaged.
- Clean the carburettor area.
- Clean the exterior of the spark plug.
- Remove it and check the electrode gap.
- Adjust it to 0,5 mm (.020"), or change the spark plug.
- Clean the cooling fins on the cylinder and check that the air intake at the starter is not clogged.
- Fill the gearbox with grease. This should be carried out after approximately every 20 working hours.
- Clean the air filter.
- Clean the spark arrester screen at muffler. Replace if damaged.

Monthly maintenance

- Rinse the fuel tank with gasoline.
- Clean the exterior of the carburettor and the space around it.
- Clean the fan and the space around it.
- Check fuel hose for cracks or other damage. Change if necessary.
- Change fuel filter in fuel tank.
- Check clutch, clutch spring and clutch drum for wear.
Change if necessary.
- Check electrical wires and connections.
- Change the spark plug.
- Change the airfilter.

Yearly maintenance

- The muffler should be changed once a year for full performance.

TECHNICAL DATA

Technical data	H60	H75
Engine		
Cylinder capacity, cm ³	25,4	25,4
Cylinder bore, mm	34	34
Stroke length, mm	28	28
Idling speed, rpm	2.700	2.700
Recommended max. speed rpm	11.000-12.000	11.000-12.000
Max. speed, should not be exceeded, rpm	14.000	14.000
Max. engine output, acc. to ISO 8893	0,9 kW/9.000 rpm	0,9 kW/9.000 rpm
Ignition system		
Manufacturer/type of ignition system	Walbro MB/CD	Walbro MB/CD
Spark plug	Champion RCJ 7Y	Champion RCJ 7Y
Electrod gap, mm	0,5	0,5
Fuel lubrication system		
Manufacturer/type of carburettor	Walbro WT	Walbro WT
Fuel tank capacity, litres	0,4	0,4
Weight		
Weight without fuel, kg	5,3	5,5
Noise levels		
Equivalent noise pressure levels at the user's ear , measured acc. to prEN 31806 and ISO 7917, dB(A):	95,1	95,1
Equivalent noise output levels measured acc. to prEN 31806 and ISO 10884, dB(A):	103,2	103,2
Vibration levels		
Vibration levels on the handles measured acc. to prEN 31806 and ISO 7916, m/s ²		
Idling, rear/front handles:	2,3/2,0	2,2/1,5
Max. speed , rear/front handles:	3,0/2,3	2,2/1,5
Blades		
Type:	Double sided	Double sided
Length, mm:	600	750
Blade speed at 7800 rpm, Cut/min:	2480	2480

YOUR WARRANTY RIGHTS AND OBLIGATIONS

The EPA, California Air Resources Board and Husqvarna Forest & Garden are pleased to explain the emissions control system warranty on your 1997 and later Lawn and Garden Equipment Engine. In U.S., new utility and lawn and garden equipment engines must be designed, built and equipped to meet the federal and California stringent anti-smog standards. Husqvarna Forest & Garden must warrant the emission control system on your Lawn and Garden Equipment Engine for the periods of time listed below provided there has been no abuse, neglect or improper maintenance of your unit. Your emission control system includes Parts such as the carburetor and the ignition system.

Where a warrantable condition exists, Husqvarna Forest & Garden will repair your Lawn and Garden Equipment Engine at no cost to you. Expenses covered under warranty include diagnosis, parts and labor.

MANUFACTURER'S WARRANTY COVERAGE

The 1997 and later utility and lawn and garden equipment engines are warranted for two years. If any emission related part on your engine (as listed above) is defective, the part will be repaired or replaced by Husqvarna Forest & Garden.

OWNER'S WARRANTY RESPONSIBILITIES

As the Lawn and Garden Equipment Engine owner, you are responsible for the performance of the required maintenance listed in your Owner's Manual. Husqvarna Forest & Garden recommends that you retain all receipts covering maintenance on your Lawn and Garden Equipment Engine, but Husqvarna Forest & Garden cannot deny warranty solely for the lack of receipts or for your failure to ensure the performance of all scheduled maintenance.

As the Lawn and Garden Equipment Engine owner, you should, however, be aware that Husqvarna Forest & Garden may deny you warranty coverage if your Lawn and Garden Equipment Engine or a part of it has failed due to abuse, neglect, improper maintenance, unapproved modifications or the use of parts not made or approved by the original equipment manufacturer.

You are responsible for presenting your Lawn and Garden Equipment Engine to a Husqvarna Forest & Garden authorized servicing dealer as soon as a problem exists. The warranty repairs should be completed in a reasonable amount of time, not to exceed 30 days.

If you have any questions regarding your warranty rights and responsibilities, you should contact your nearest authorized servicing dealer or call Husqvarna Forest & Garden at 1-800-487-5963.

WARRANTY COMMENCEMENT DATE

The warranty period begins on the date Lawn and Garden Equipment Engine is delivered.

LENGTH OF COVERAGE

Husqvarna Forest & Garden warrants to the initial owner and each subsequent purchaser that the engine is free from defects in materials and workmanship which cause the failure of a warranted part for a period of two years.

WHAT IS COVERED

REPAIR OR REPLACEMENT OF PARTS

Repair or replacement of any warranted part will be performed at no charge to the owner at an approved Husqvarna Forest & Garden servicing dealer.

If you have any questions regarding your warranty rights and responsibilities, you should contact your nearest authorized servicing dealer or call Husqvarna Forest & Garden at 1-800-487-5963.

WARRANTY PERIOD

Any warranted part which is not scheduled for replacement as required maintenance, or which is scheduled only for regular inspection to the effect of "repair or replace as necessary" shall be warranted for 2 years. Any warranted part which is scheduled for replacement as required maintenance shall be warranted for the period of time up to the first scheduled replacement point for that part.

DIAGNOSIS

The owner shall not be charged for diagnostic labor which leads to the determination that a warranted part is defective, if the diagnostic work is performed at an approved Husqvarna Forest & Garden servicing dealer.

CONSEQUENTIAL DAMAGES

Husqvarna Forest & Garden may be liable for damages to other engine components caused by the failure of a warranted part still under warranty.

WHAT IS NOT COVERED

All failures caused by abuse, neglect or improper maintenance are not covered.

ADD-ON OR MODIFIED PARTS

The use of add-on or modified parts can be grounds for disallowing a warranty claim. Husqvarna Forest & Garden is not liable to cover failures of warranted parts caused by the use of add-on or modified parts.

HOW TO FILE A CLAIM

If you have any questions regarding your warranty rights and responsibilities, you should contact your nearest authorized servicing dealer or call Husqvarna Forest & Garden at 1-800-487-5963.

WHERE TO GET WARRANTY SERVICE

Warranty services or repairs shall be provided at all Husqvarna Forest & Garden authorized servicing dealers.

MAINTENANCE, REPLACEMENT AND REPAIR OF EMISSION-RELATED PARTS

Any Husqvarna Forest & Garden approved replacement part used in the performance of any warranty maintenance or repairs on emission-related parts, will be provided without charge to the owner if the part is under warranty.

EMISSION CONTROL WARRANTY PARTS LIST

1. Carburetor and internal parts
2. Intake pipe, airfilter holder and carburetor bolts.
3. Airfilter and fuelfilter covered up to maintenance schedule.
4. Ignition System
 - a) Spark Plug, covered up to maintenance schedule
 - b) Ignition Module
5. Muffler with catalytic converter

MAINTENANCE STATEMENT

The owner is responsible for the performance of all required maintenance, as defined in the operator's manual.