

GTH 220

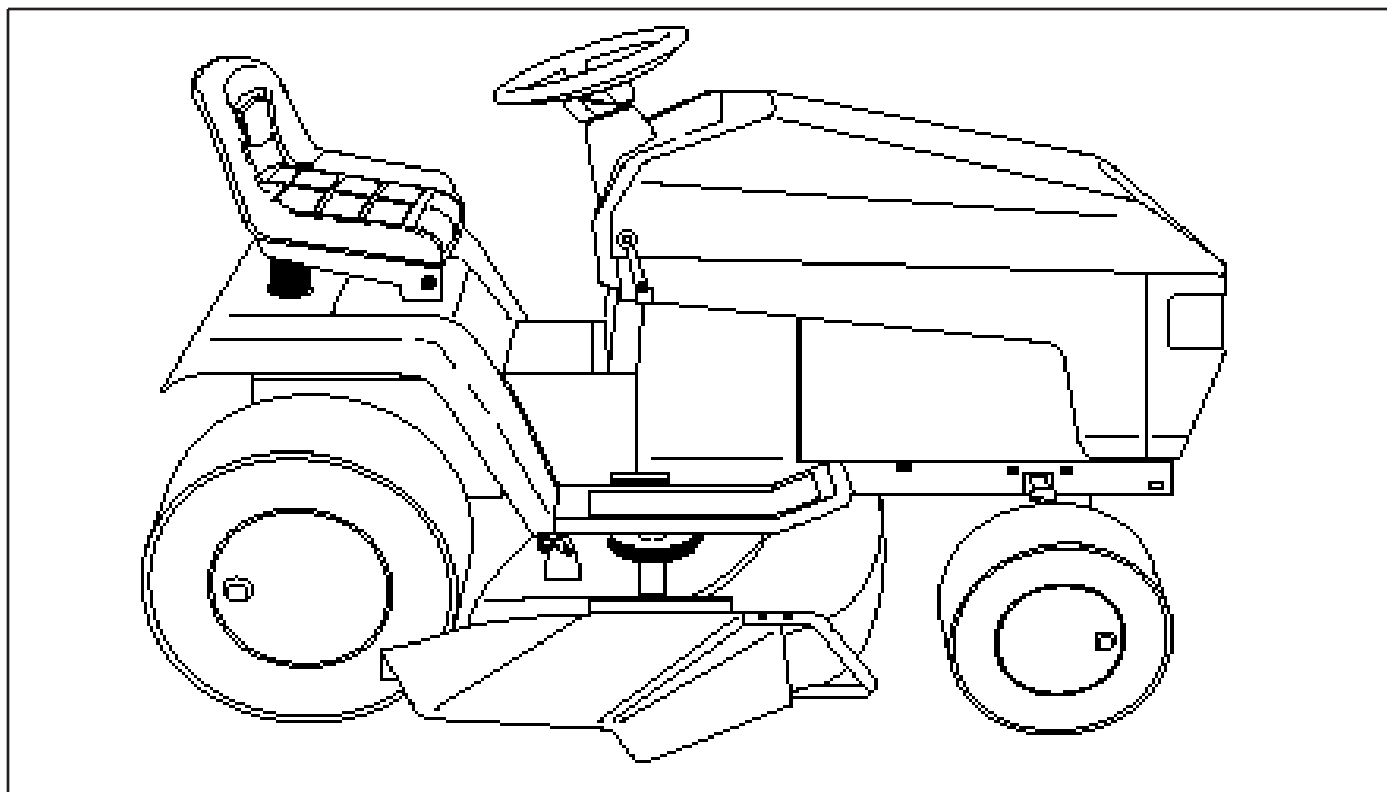

07.1998
PARTS LISTING

954140012D

TRACTOR - MODEL NO. GTH220 (954140012D), PRODUCT NO. 954 14 00-12

SCHEMATIC

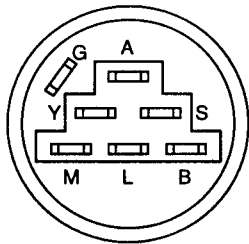
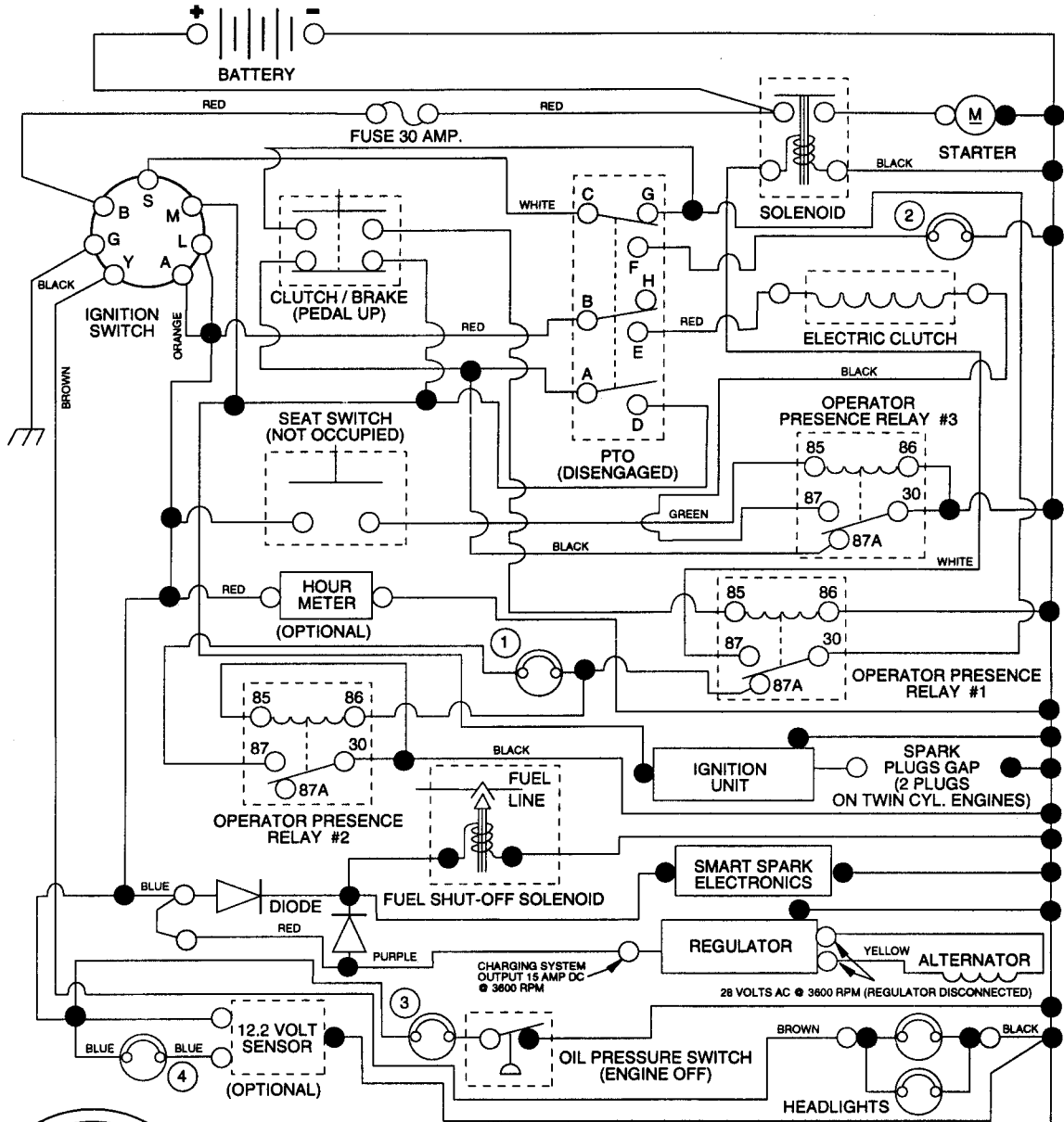

IGNITION SWITCH

POSITION	CIRCUIT	"MAKE"
OFF	G + M + L	NONE
RUN/LIGHT	B + L	A + Y
RUN	B + L	NONE
START	B + L + S	NONE

INDICATOR LIGHTS

- ① DEPRESS FOOT PEDAL
- ② DISENGAGE ATTACHMENT
- ③ CHECK OIL
- ④ BATTERY DISCHARGING

NOTE
YOUR TRACTOR IS EQUIPPED WITH A SPECIAL ALTERNATOR SYSTEM. THE LIGHTS ARE NOT CONNECTED TO THE BATTERY, BUT HAVE THEIR OWN ELECTRICAL SOURCE. BECAUSE OF THIS, THE BRIGHTNESS OF THE LIGHTS WILL CHANGE WITH ENGINE SPEED. AT IDLE THE LIGHTS WILL DIM. AS THE ENGINE IS SPEEDED UP, THE LIGHTS WILL BECOME THEIR BRIGHTEST.

WIRING INSULATED CLIPS
NOTE: IF WIRING INSULATED CLIPS WERE REMOVED FOR SERVICING OF UNIT, THEY SHOULD BE REPLACED TO PROPERLY SECURE YOUR WIRING.

PTO SWITCH

POSITION	CIRCUIT
OFF	C + G, B + H
ON	C + F, B + E, A + D

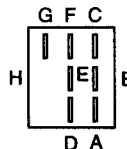

TRACTOR ENGINE

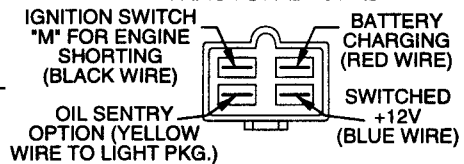

TRACTOR CONNECTOR

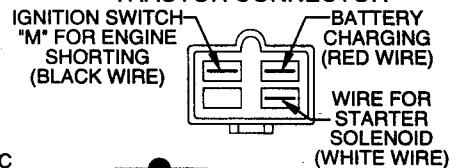

NON-REMOVABLE CONNECTIONS
REMOVABLE CONNECTIONS

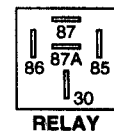

REPAIR PARTS

TRACTOR - MODEL NO. GTH220 (954140012D), PRODUCT NO. 954 14 00-12
ELECTRICAL

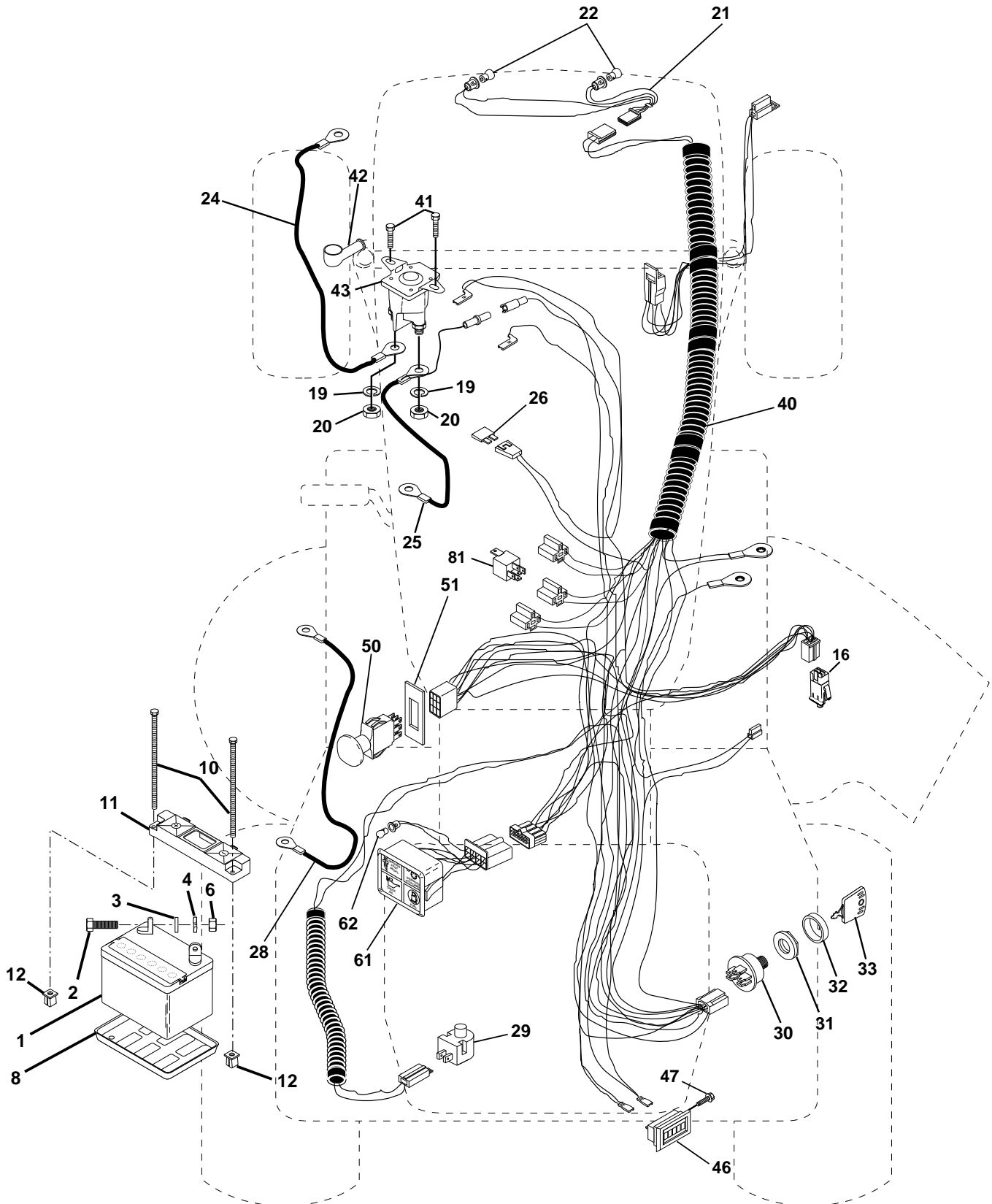

REPAIR PARTS

TRACTOR - MODEL NO. GTH220 (954140012D), PRODUCT NO. 954 14 00-12
ELECTRICAL

KEY NO.	PART NO.	DESCRIPTION
1	532144927	Battery
2	874760412	Bolt Hex Head 1/4-20 x 3/4
3	810040400	Washer, Lock 1/4
4	819091016	Washer 9/32 x 5/8 x 16 Ga
6	873220400	Nut Fin Hex 1/4-20
8	532124886	Tray, Battery
10	532145211	Bolt, Btr Frt 1/4-20 x 7-1/2 Zinc
11	532150109	Holddown Battery Front Mount
12	532145769	Nut Push Nylon 1/4" Battery Frt.
16	532153664	Switch Interlock Push-In
19	810090400	Washer, Lock 1/4
20	873350400	Nut, Jam Hex 1/4-20
21	532136850	Harness Socket Light w/4152J
22	532004152	Bulb Light
24	532004014	Cable, Starter
25	532146686	Cable, Battery
26	532108824	Fuse
28	532157899	Cable, Ground
29	532160784	Switch, Plunger
30	532140301	Switch, Ign
31	532124211	Nut, Ignition Switch
32	532141226	Cover Switch Key
33	532122147	Key
40	532160730	Harness Ign.
41	817720408	Screw 1/4-20 x 1/2
42	532131563	Cover, Terminal Red
43	532145673	Solenoid
46	532110940	Meter Hour
47	817011008	Screw #10-24 x 1/2
50	532154959	Switch, PTO
51	532140405	Ring Retainer PTO
61	532138101	Light Pkg Asm
62	532110143	Bulb, Light Pkg.
81	532109748	Relay Asm.

NOTE: All component dimensions given in U.S. inches
1 inch = 25.4 mm

REPAIR PARTS

TRACTOR - MODEL NO. GTH220 (954140012D), PRODUCT NO. 954 14 00-12
CHASSIS AND ENCLOSURES

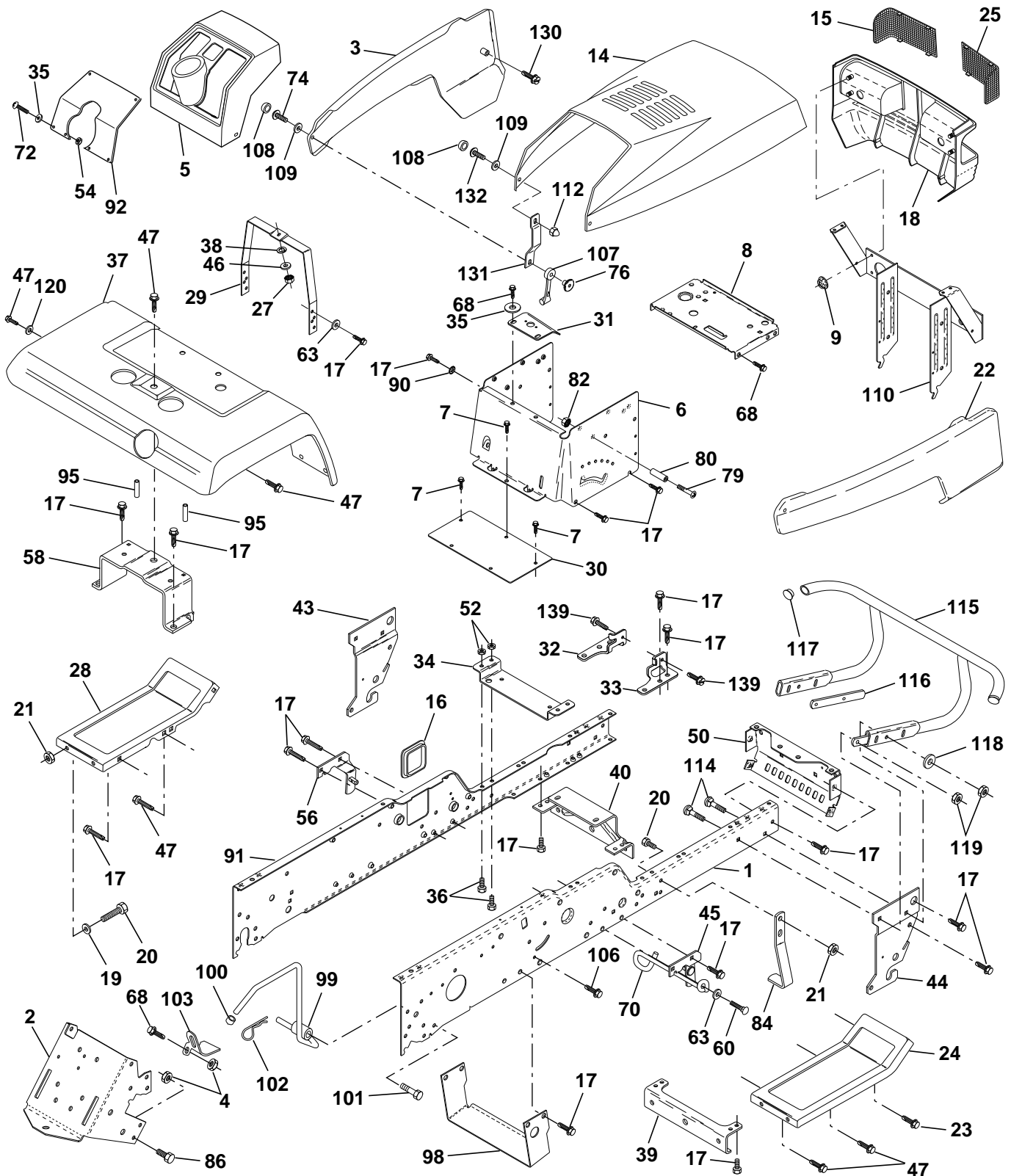

REPAIR PARTS

TRACTOR - MODEL NO. GTH220 (954140012D), PRODUCT NO. 954 14 00-12

CHASSIS AND ENCLOSURES

KEY NO.	PART NO.	DESCRIPTION	KEY NO.	PART NO.	DESCRIPTION
1	532150253	Rail, Frame RH	58	532137113	Bracket Asm., Fender
2	532140506	Drawbar, Gt	60	817490620	Screw Thdrol 3/8-16 x 1-1/4
3	532150478	Panel Asm., Side LH	63	819131614	Washer 13/32 x 1 x 14 Ga.
4	873800700	Nut, Lock Hex 7/16 Unc	68	817490508	Screw, Thdrol 5/16-18 x 1/2
5	532140452	Dash, Plastic Black	70	532137159	Guide, Belt Mid Span
6	532157882	Dash 1-PCS, Lower	72	874180512	Screw, Mach Trhd 5/16-18 x 3/4
7	817720408	Screw, Thd Cut 1/4-20 x 1/2	74	874191008	Screw, Machine #10-24
8	532145166	Support, Battery	76	532125004	Nut, Weld #10-24
9	532108067	Nut Pal	79	874981020	Screw, Machine #10-24 x 1/4
14	532150477	Hood Asm., Pnt	80	532007206	Spacer, Split
15	532157068	Lens, Headlight LH	82	873731000	Nut #10-24
16	532121794	Cover, Access	84	532142992	Stop, Over Center 44" 20/23" T. 94
17	817490612	Screw, Thdrol 3/8-16 x 3/4	86	874760716	Bolt, Fin Hex 7/16-14 Unc x 1
18	532157236	Grille	90	811050600	Washer, Lock External Tooth 3/8
19	819131312	Washer 13/32 x 13/16 x 12 Ga.	91	532156586	Rail, Frame Lh
20	874760616	Bolt, Fin Hex 3/8-16 x 1	92	532157221	Plate, Silkscreen Dash
21	873680600	Nut, Crownlock 3/8-16 Unc	95	532105531	Push Nut, Nylon
22	532150479	Panel Asm., Side RH	98	532140503	Bracket Chassis Skid
23	817490616	Screw Thdrol. 3/8-16 x 1 Ty-TT	99	532140871	Rod Asm. Bypass
24	532147202	Footrest, RH	100	532124236	Cap Brake Parking Red
25	532157069	Lens Headlight RH	101	817490628	Screw Thdrol. 3/8-16 x 1-3/4
27	873220400	Nut Fin Hex 1/4-20	102	532124788	Retainer Spring 1"
28	532147203	Footrest, LH	103	532142273	Bracket Lock Bypass
29	532145205	Bracket, Support Dash	106	532138776	Screw Thdrol. Hex Hd Zinc Mur
30	532145052	Saddle	107	532109808	Latch, Chute Blk
31	532161419	Brace, Support Steering	108	532110356	Cap, Snap Black
32	532161327	Bracket Asm., Frame Pivot Lh	109	532110357	Cap, Washer Snap
33	532161326	Bracket Asm., Frame Pivot Rh	110	532150200	Pivot Asm. Grille/Hood Husq. VGT
34	532142131	Bracket, Engine Support Rear	112	532060867	Nut, Acorn, Hex #10-24
35	819111116	Washer 11/32 x 11/16 x 16 Ga.	114	872140610	Bolt, Carriage 3/8-16 x 1-1/4
36	874780512	Bolt, Fin Hex 5/16-18 x 3/4	115	532150300	Bumper Asm.
37	532141449	Fender, Pnt.	116	532141461	Bracket Extension Bumper
38	810040400	Washer, Lock 1/4	117	532143679	Plug Plastic
39	532136961	Bracket, Axle Front	118	819131316	Washer 13/32 x 13/16 x 16 Ga.
40	532156111	Bracket, Support Axle/Engine	119	873680600	Nut Crownlock 3/8-16 UNC
43	532136939	Bracket, Spnsn Front Lh	120	819131616	Washer 13/32 x 1 x 16 Ga.
44	532136940	Bracket, Spnsn Front Rh	130	817521312	Screw, SLTD Hex Hd. W/PI Washer
45	532154913	Bracket Asm., Susp Chassis Rh	131	532150195	Bracket Support Hood/Panel YP
46	819091216	Washer 9/32 x 3/4 x 16 Ga.	132	874291006	Screw Truss Hd. #10-24 x 3/8
47	817490608	Screw Thdrol 3/8-16 x 1/2	139	161330	Bolt, Shoulder 5/16-18 TT
50	532152728	Bracket, Chassis Front	--	532125085	Plug, Hole
52	873800500	Locknut, Hex W/Ins 5/16-18 Unc			
54	873510500	Nut 5/16-18			
56	532154914	Bracket Asm., Susp Chassis Lh			

NOTE: All component dimensions given in U.S. inches
1 inch = 25.4 mm

REPAIR PARTS

TRACTOR - MODEL NO. GTH220 (954140012D), PRODUCT NO. 954 14 00-12
GROUND DRIVE

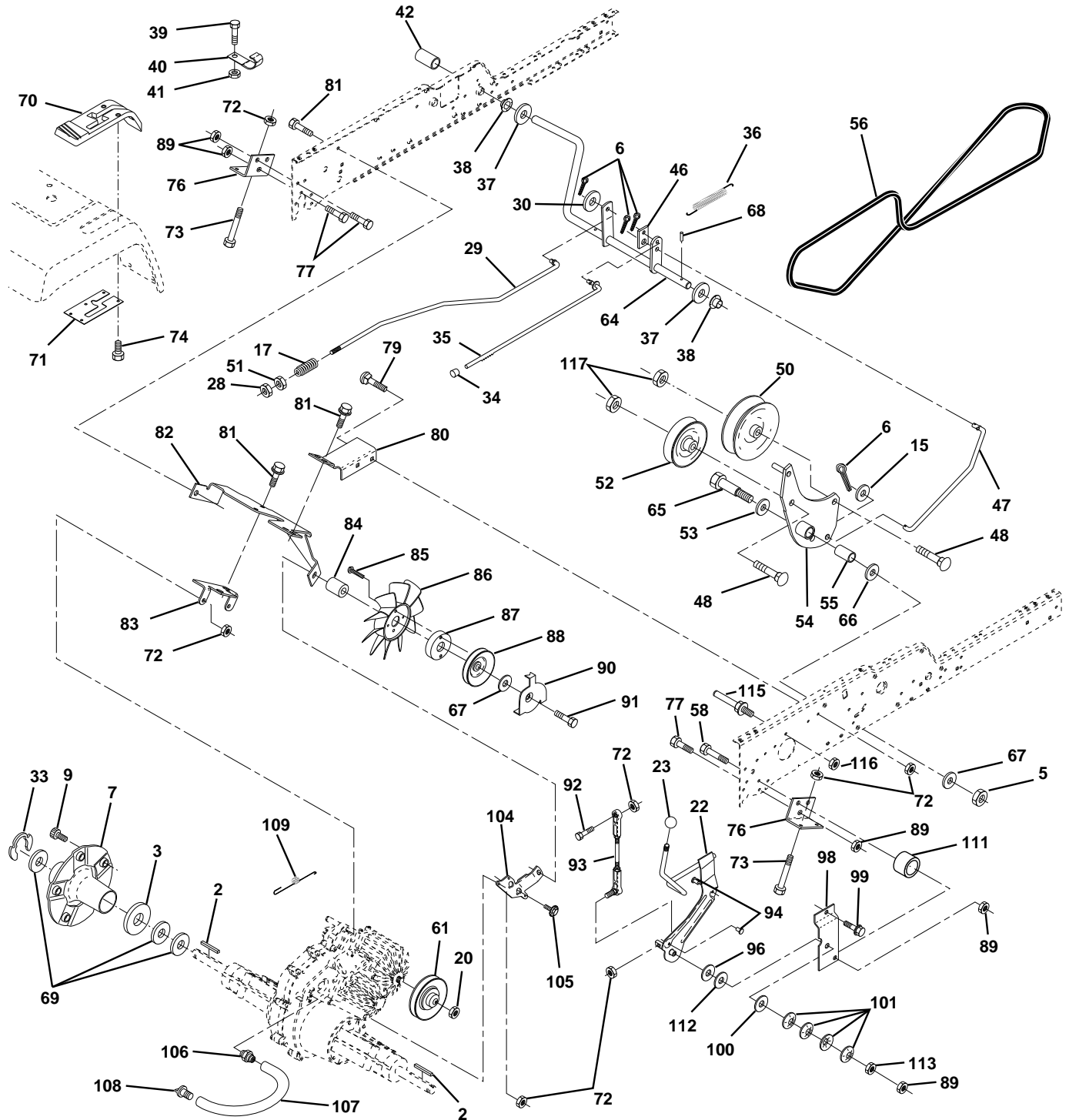

REPAIR PARTS

TRACTOR - MODEL NO. GTH220 (954140012D), PRODUCT NO. 954 14 00-12

GROUND DRIVE

KEY NO.	PART NO.	DESCRIPTION	KEY NO.	PART NO.	DESCRIPTION
2	532007070	Key 1/4 x 2.5	71	532151179	Plate Console Shift
3	532007563	Washer Thrust Axle Harden	72	873800500	Locknut Hex W/Washer Insert
5	873680600	Nut Crownlock 3/8-16	73	874490548	Bolt Hex FLGHD 5/16-18 x 3 Gr 5
6	876020412	Pin Cotter 1/8 x 3/4	74	532142432	Screw, Hex Wsh Hi-Lo 1/4-1/2
7	532140507	Wheel Hub Asm.	76	532140481	Bracket Transaxle
9	532140080	Bolt Hub	77	874760716	Bolt Fin Hex 7/16-14 x 1
15	819131316	Washer 13/32 x 13/16 x 16 Ga.	79	872110505	Bolt Carriage 5/16-18 x 5/8
17	532140921	Spring Rod Brake	80	532140484	Bracket Torque RH
20	873940800	Nut Hex Jam Toplock 1/2-20	81	817490612	Screw Thdrol 3/8-16 x 3/4
22	532156103	Shaft Arm Asm	82	532150586	Bracket Mount Torque/Fan
23	532140845	Knob	83	532140479	Strap Torque Mid
28	873350600	Nut, Hex Jam 3/8-16	84	532140490	Spacer
29	532140494	Brake Rod	85	817541020	Screw #10-24 x 1-1/4
30	819131616	Washer 13/32 x 1 x 16Ga	86	532140462	Fan 7" Hydro
33	812000053	Ring E	87	532140491	Adapter Fan
34	532071673	Cap Plunger	88	532161592	Pulley Idler
35	532137648	Rod Parking Brake	89	873680700	Nut, Crownlock 7/16-14
36	532149412	Spring Drive Ground	90	532140489	Keeper Belt
37	532121749	Washer 25/32 x 1-1/4 x 16 Ga.	91	817490644	Screw Thdrol 3/8-16 x 2-3/4
38	532150035	Nyliner	92	874760520	Bolt Fin Hex 5/16-18 x 1.75
39	874321016	Screw Fin #10-24 x 1	93	532140502	Link Shift Asm
40	532005304	Actuator Interlock Switch	94	532133835	Fastner Christmas Tree
41	873661000	Nut Toplock #10-24 UNC	96	532141103	Washer Nickel Plated
42	532123533	Cover Pedal	98	532141004	Bracket Shift
46	532145170	Retainer Spring	99	817490624	Screw Thdrol 3/8-16 x 1-1/2
47	532138228	Clutch Rod	100	532126881	Washer Compression
48	872110612	Bolt Carriage 3/8-16 x 1-1/2 Gr. 5	101	532156106	Washer Bellville
50	532131494	Pulley Idler Flat	104	532140480	Bracket Idler
51	873800600	Nut Lock Hex 3/8-16	105	817580408	Screw Tap 1/4-20 x 1/2
52	532139123	Pulley Idler Grooved	106	532142918	O-Ring Asm. Hydro Gear
53	532000207	Washer Hardened	107	532154739	Line Fuel Hydro
54	532161590	Clutch Arm Asm	108	532142917	Cap Vent
55	532105706	Bearing, Idler	109	532140929	Spring Return Brake
56	532140218	V-Belt	111	532156240	Spacer Shift Lever VGTH
58	874760724	Bolt Fin Hex 7/16-14 x 1-1/2	112	532156104	Washer Nylon High Temp
61	532140488	Pullery Transaxle	113	873220700	Nut Hex ASF 7/16-14 UNC
64	532154752	Shaft Asm Brake Parking Clutch	115	532123405	Keeper Belt Gnd Dr.
65	532067609	Bolt Shoulder	116	873900500	Nut Lock Hex Flange 5/16-18
66	532140296	Washer Hardened	117	873900600	Nut Lock Fig. 3/8-16 UNC
67	819131312	Washer 13/32 x 13/16 x 12 Ga	--	532163198	Transaxle Hydro
68	532005142	Pin Roll			
69	532123800	Washer			
70	532151146	Console Hydro Fender			

NOTE: All component dimensions given in U.S. inches
1 inch = 25.4 mm

REPAIR PARTS

TRACTOR - MODEL NO. GTH220 (954140012D), PRODUCT NO. 954 14 00-12
STEERING ASSEMBLY

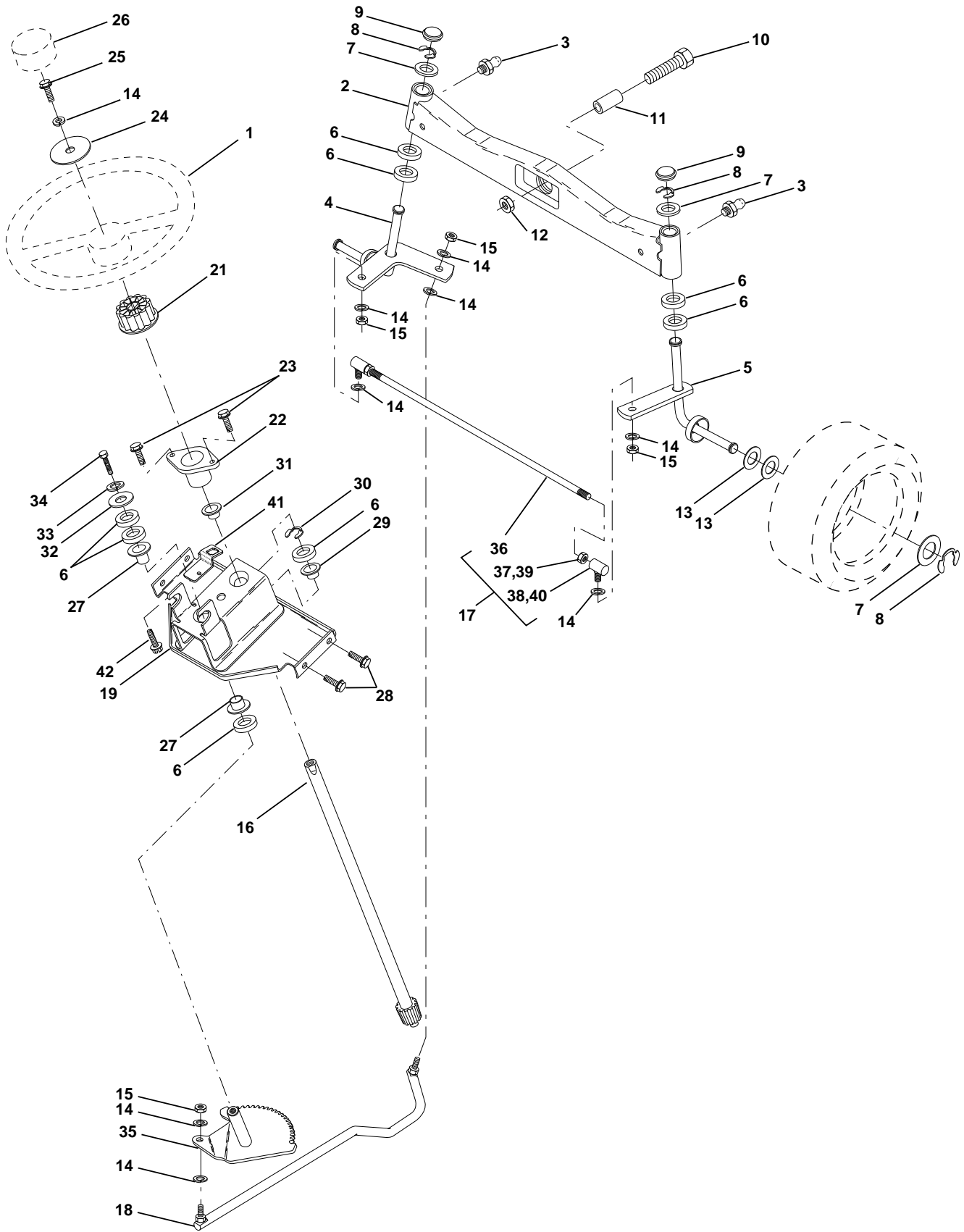

REPAIR PARTS

TRACTOR - MODEL NO. GTH220 (954140012D), PRODUCT NO. 954 14 00-12 STEERING ASSEMBLY

KEY NO.	PART NO.	DESCRIPTION
1	532124415	Wheel, Steering
2	532137094	Axle Asm., Front
3	532124836	Fitting, Grease
4	532161849	Spindle Asm, LH
5	532161848	Spindle Asm., RH
6	532124931	Bearing, Race Thrust Harden
7	532121748	Washer 25/32 x 1-5/8 x 16 Ga.
8	812000029	Ring, Klip #T5304-75
9	532121232	Cap, Spindle
10	874781044	Bolt, Fin Hex 5/8-11 x 2-3/4
11	532136518	Spacer, Brg. Axle Front
12	873901000	Nut, Lock Flange 5/8-11 Unc
13	532121749	Washer 25/32 x 1-1/4 x 16 Ga.
14	810040600	Washer, Lock Hvy Hlcl Spr 3/8
15	532124701	Nut, Lock Center 3/8-24 Unf
16	532145103	Shaft Asm., Steering
17	532137347	Rod Asm., Tie Ball J Ball Vgt (Inc. Key No. 36-40)
18	532137155	Draglink, Ball Joint Solid Vgt
19	532156011	Support Asm., Steering Vgt
21	532100711	Adapter, Wheel Steering
22	532155105	Bushing, Strg.
23	532152927	Screw
24	819133808	Washer 13/32 x 2-3/8 x 8 Ga.
25	874780616	Bolt, Fin Hex 3/8-16 x 1 Gr. 5
26	532124416	Cap, Wheel Steering
27	532124937	Bearing, Col. Strg.
28	817490612	Screw Thdrol 3/8-16 x 3/4
29	532104239	Bearing, Flange
30	812000034	Ring, Klip Truarc #5304-75
31	532138136	Bushing, Nyliner Snap
32	819111610	Washer 11/32 x 1 x 10 Ga.
33	810040500	Washer, Lock Hvy Hlcl Spr 5/16
34	874760512	Bolt, Hex Hd 5/16-18 x 3/4
35	532138059	Gear, Sector Steering
36	532137156	Tie Rod
37	873360600	Jam Nut RH Thread
38	532109850	Joint Asm. Ball RH Thread
39	873700600	Jam Nut LH Thread
40	532109851	Joint Asm. Ball LH Thread
41	532155246	Bracket Switch Interloc
42	817490508	Screw Thdrol 5/16-18 x 1/2 Tyt

NOTE: All component dimensions given in U.S. inches
1 inch = 25.4 mm

REPAIR PARTS

TRACTOR - MODEL NO. GTH220 (954140012D), PRODUCT NO. 954 14 00-12
ENGINE

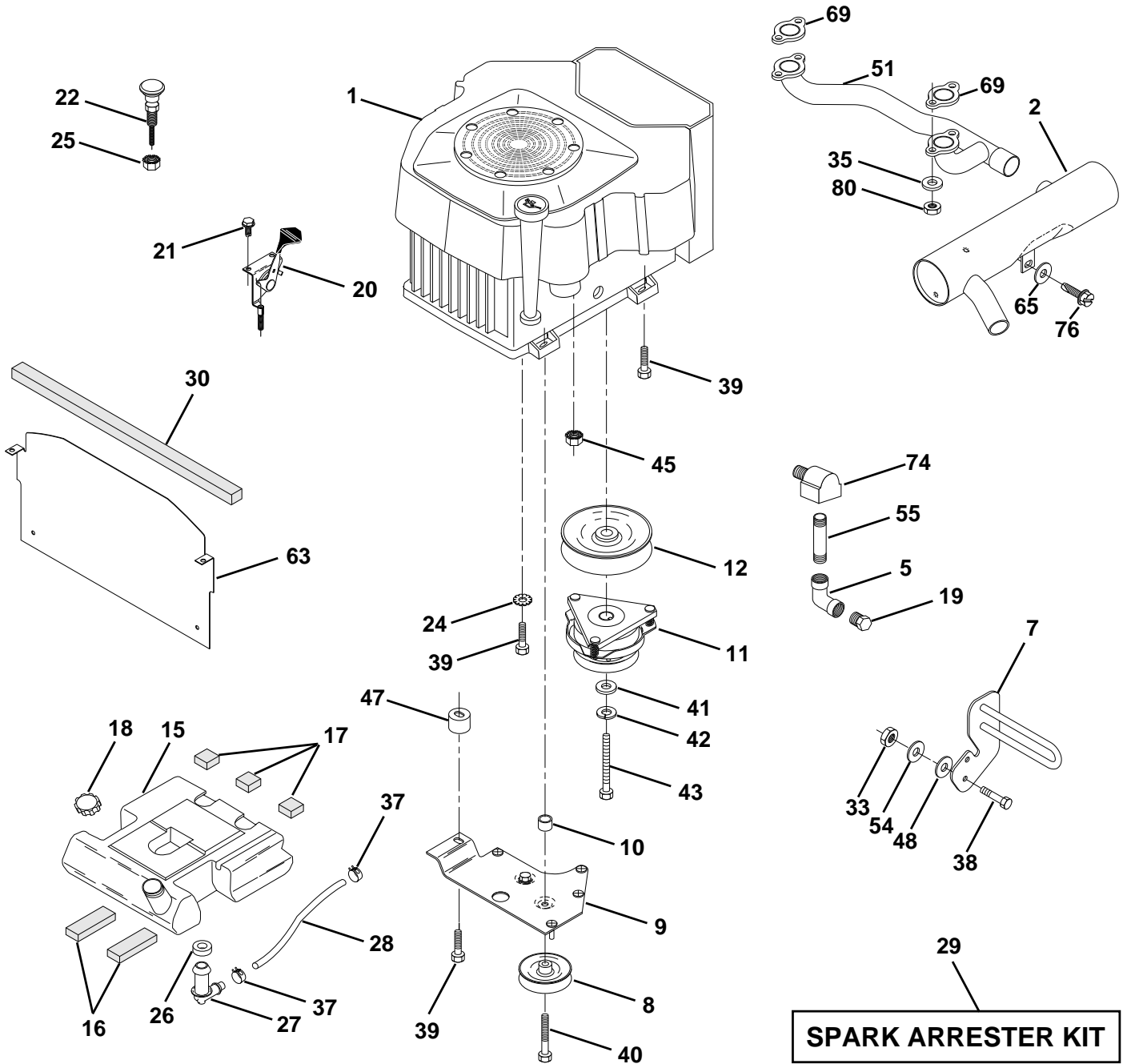

REPAIR PARTS

TRACTOR - MODEL NO. GTH220 (954140012D), PRODUCT NO. 954 14 00-12
ENGINE

KEY NO.	PART NO.	DESCRIPTION
1	-----	Engine Kohler, Model No. CV22S
2	532161062	Muffler Side 1-1/8"
5	813200300	Elbow STD 90 Degree 3/8-18 NPT
7	532151396	Muffler Assembly Guard
8	532121361	Pulley V-Idler
9	532150828	Keeper Asm Belt Engine VGT 96
10	532105432	Bushing
11	532140923	Clutch Electric
12	532143996	Pulley Engine VGT Elect Clutch
15	532151346	Tank Fuel Rear
16	532109227	Pad Spacer
17	532106082	Pad Spacer
18	532140527	Cap Asm Fuel W/Sym Vented
19	813290300	Plug Oil Drain (Order From Engine Manufacturer)
20	532132747	Control Throttle
21	817720410	Screw Hex Thd Cut 1/4-20 X 5/8
22	532132781	Control Choke
24	811050600	Washer Ext Tooth 3/8
25	873920600	Nut Keps 3/8 - 24 UNF
26	532124952	Bushing
27	532139277	Stem Tank Fuel
28	532124703	Fuel Line
29	532132920	Spark Arrester Kit
30	532105037	Strip Foam 18"
33	873800600	Nut, Hex W/Ins. 3/8-16 UNC
35	810010500	Washer Split
37	532123487	Clamp Hose
38	874780624	Bolt, Fin Hex 3/8-16 UNC x 1-1/2
39	817490636	Screw TT 3/8-16 x 2-1/4 UNC
40	817490664	Screw TT 3/8-16 x 4 UNC
41	532126197	Washer 1-1/2 OD X 15/32 ID X .250
42	810040700	Washer Lock 7/16
43	532150280	Bolt Hex 7/16-20 X 4-1/4 Ga 5
45	532128861	Nut Flange 1/4-20 Starter Nut
47	532142040	Spacer Engine
48	819132007	Washer 13/32 x 1-1/4 x 7 Ga.
51	532161230	Manifold Pipe VGT CV 1-1/8
54	819131414	Washer Flat 13/32 x 7/8 x 14 Ga.
55	813280336	Nipple, Pipe 4-1/2"
63	532145549	Shield, Heat VGT YP/Husq.
65	819131614	Washer 13/32 x 1 x 14 Ga.
69	532163307	Gasket
74	532162295	Elbow Street Brass
76	817490612	Screw Thrdrol 3/8-16 x 3/4 Ty-TT
80	532163305	Nut Flange

NOTE: All component dimensions given in U.S. inches
1 inch = 25.4 mm

REPAIR PARTS

TRACTOR - MODEL NO. GTH220 (954140012D), PRODUCT NO. 954 14 00-12

SEAT ASSEMBLY

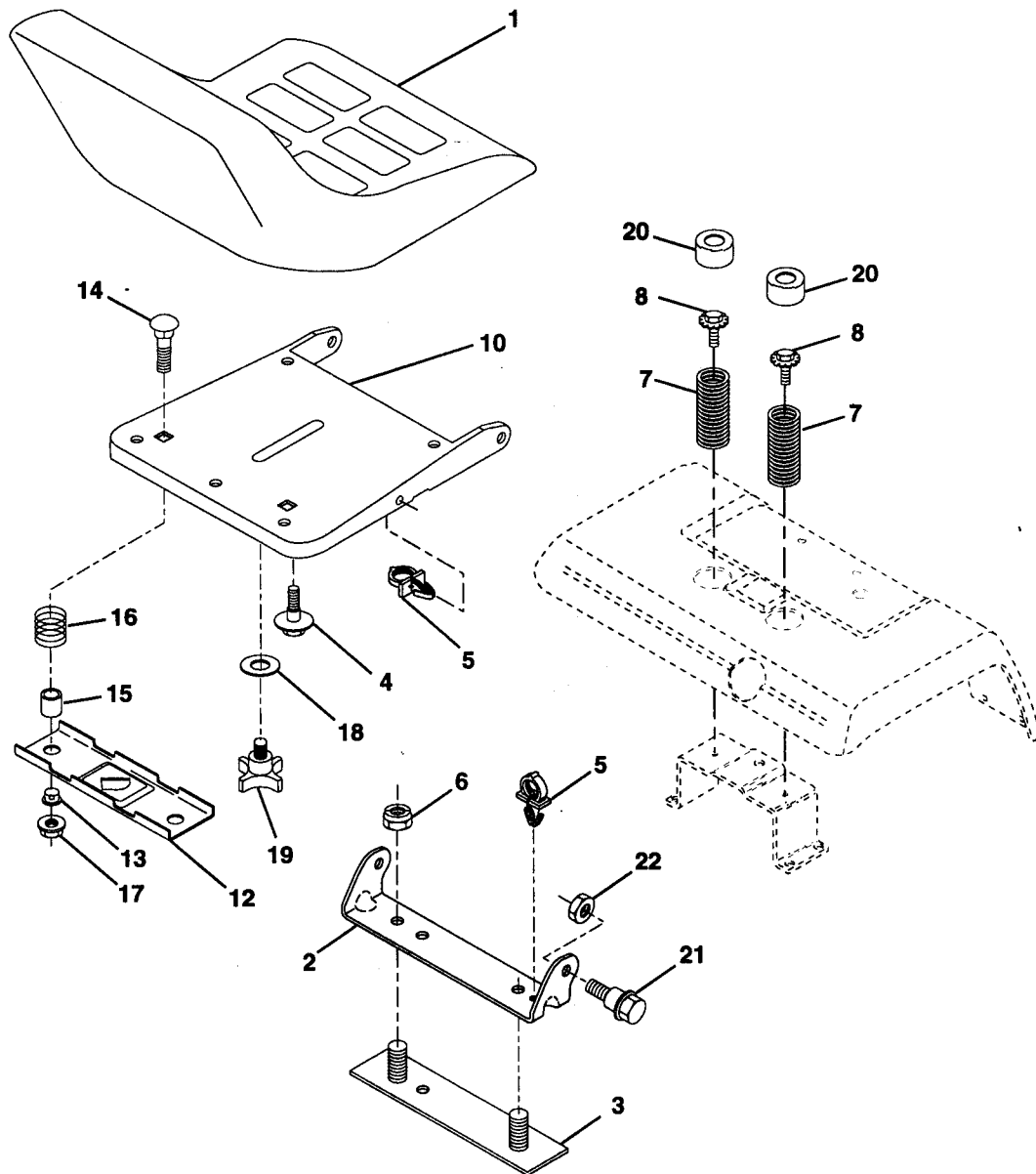

KEY NO.	PART NO.	DESCRIPTION
1	532141525	Seat
2	532140551	Bracket, Pivot Seat
3	532140675	Strap, Fender
4	532127018	Bolt, Shoulder 5/16-18 X .62
5	532145006	Clip, Push In Hinged
6	873800600	Nut, Lock Hex W/Ins. 3/8-16 Unc
7	532124181	Spring, Seat Cprsn
8	532150176	Bolt 5/16-18unc x 3/4 W/Sems
10	532155925	Pan, Seat
12	532121246	Bracket, Mounting Switch
13	532121248	Bushing, Snap

KEY NO.	PART NO.	DESCRIPTION
14	872050412	Bolt, Carriage 1/4-20 X 1-1/2
15	532121249	Spacer, Split
16	532123740	Spring, Cprsn
17	532123976	Nut, Lock 1/4 Lge Flg Gr. 5
18	819171912	Washer 17/32 X 1-3/16 X 12 Ga.
19	532120068	Knob, Seat 1/2-13 Unc
20	532124238	Cap, Spring Seat
21	532153236	Bolt, Shoulder 5/16-18 Unc-2A
22	873680500	Nut, Crownlock 5/16-18 Unc

NOTE: All component dimensions given in U.S. inches
1 inch = 25.4 mm

REPAIR PARTS

TRACTOR - MODEL NO. GTH220 (954140012D), PRODUCT NO. 954 14 00-12

DECALS

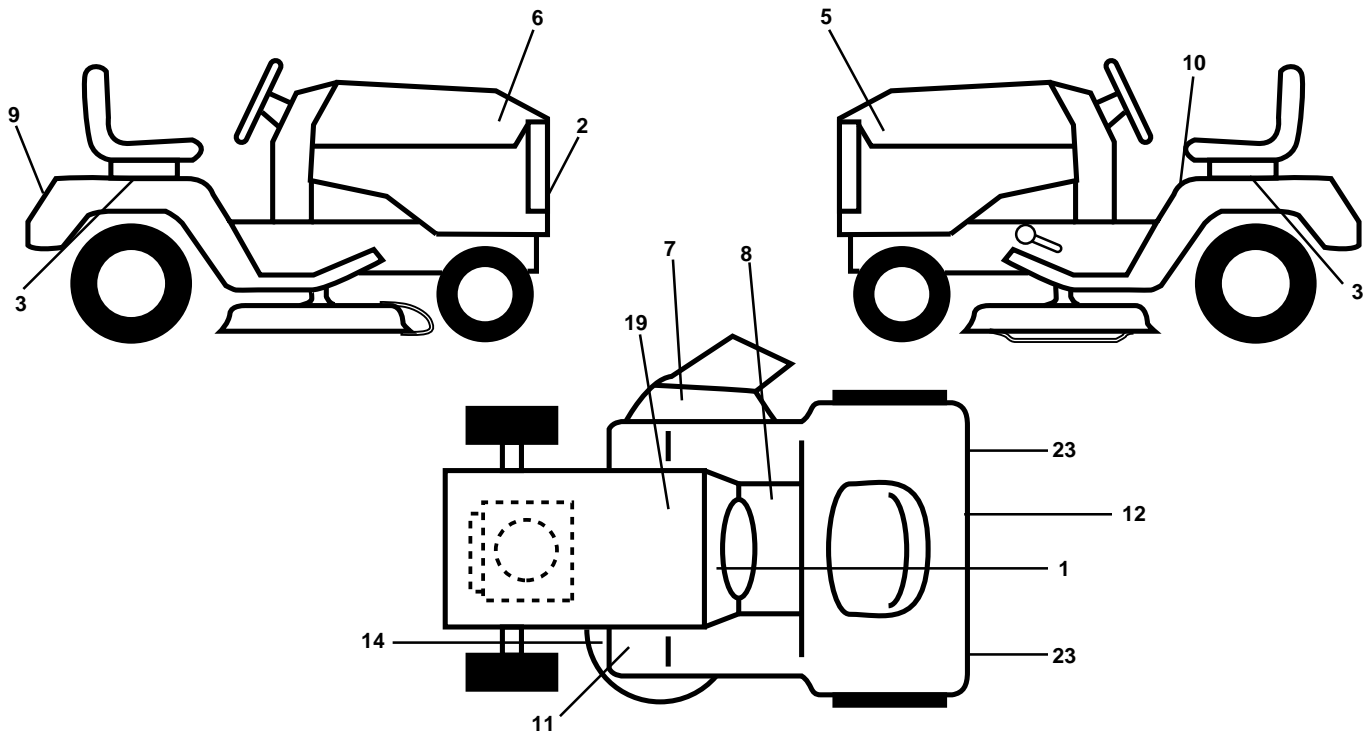

KEY NO.	PART NO.	DESCRIPTION	KEY NO.	PART NO.	DESCRIPTION
1	532156964	Decal, Operating Instruction	--	532138311	Decal, Handle Lft Height Adjust (Lift Handle)
2	532150616	Decal, Grille Husqvarna	--	532157199	Pad Frest Sq Generic 97
3	532155862	Decal, Fender Automatic	--	532164818	Manual, Owner's (English)
5	532150619	Decal, Inst Hood LH GTH220 Hydro	--	532164819	Manual, Owner's (French)
6	532150618	Decal, Insrt Hood RH GTH220 Hydro			
7	532137259	Decal, Warning Multi-Language			
8	532140837	Decal, Brake Parking Saddle			
9	532150617	Decal, Fender			
10	532157140	Decal, Danger			
11	532101892	Decal, Clutch/Brake			
12	532142342	Decal, D-Bar Ctrl. Mvt Hyd YT/GT			
14	532160397	Decal, V-Belt Schematic			
19	532145005	Decal, Battery			
23	532106202	Reflector, Taillight			

Accessories not included with tractor:

--	SH10	Sleeve Hitch
--	TA128	Tire Chains
--	GBD48	Snow Blade
--	TA321	#55 Wheel Weights
--	EA20	Electric Assist Kit
--	GSB42	Snow Blower

WHEELS & TIRES

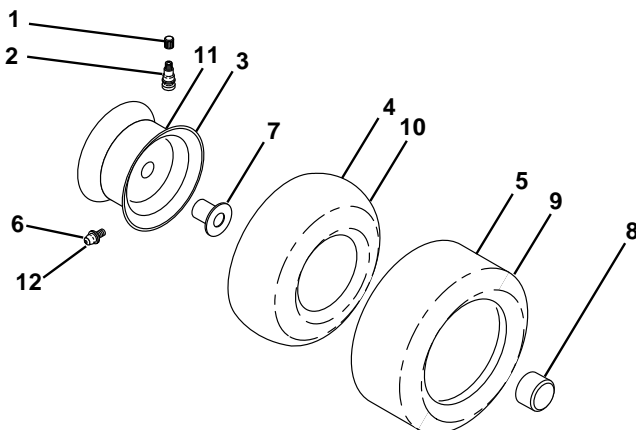

KEY NO.	PART NO.	DESCRIPTION
1	532059192	Cap, Valve, Tire
2	532065139	Stem, Valve
3	532144509	Rim Assembly, Front
4	532008134	Tube, Front (Service Item Only)
5	532106230	Tire, Front
6	532124957	Fitting, Grease
7	532124959	Bearing, Flange (Front Wheel Only)
8	532104757	Cap, Hub, Axle Blk.
9	532105588	Tire, Rear
10	532007154	Tube, Rear (Service Item Only)
11	532144510	Rim Assembly, Rear
12	532124860	Fitting Grease
--	532144334	Sealant, Tire (10 oz. Tube)

NOTE: All component dimensions given in U.S. inches
1 inch = 25.4 mm

REPAIR PARTS

TRACTOR - MODEL NO. GTH220 (954140012D), PRODUCT NO. 954 14 00-12
LIFT ASSEMBLY

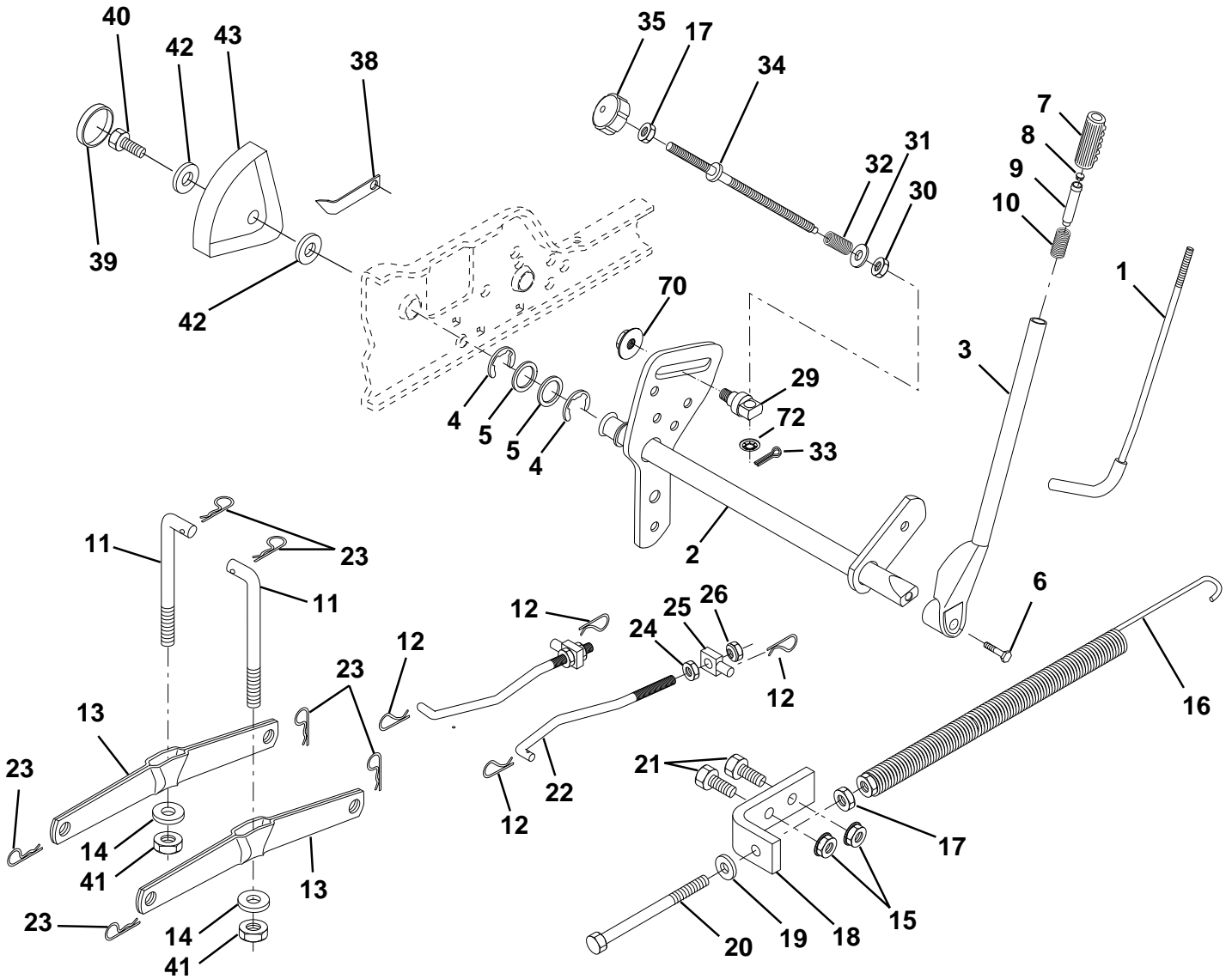

REPAIR PARTS

TRACTOR - MODEL NO. GTH220 (954140012D), PRODUCT NO. 954 14 00-12
LIFT ASSEMBLY

KEY NO.	PART NO.	DESCRIPTION
1	532121006	Rod Asm., Lever
2	532159187	Shaft Asm., Lift Vgt
3	532159189	Lever Asm., Lift Rh
4	812000022	E-Ring Truarc #5133-87
5	819292016	Washer 29/32 x 1-1/4 x 16 Ga.
6	874780624	Bolt, Fin Hex 3/8-16 x 1-1/2
7	532125631	Grip, Handle Fluted
8	532124526	Button, Plunger
9	532122364	Plunger, Lever Lift
10	532124874	Spring 2-1/8"
11	532146704	Link Lift
12	532163552	Retainer, Spring
13	532139868	Arm, Suspension Vgt
14	532140302	Bearing
15	873680600	Nut, Crownlock 3/8-16 Unc
16	532124687	Spring Asm., Assist Lift
17	873350600	Nut, Hex Jam 3/8-16 Unc
18	532143363	Bracket, Spring Assist
19	819131316	Washer 13/32 x 13/16 x 16 Ga.
20	532005328	Bolt, Adjust Spring Assist
21	874760616	Bolt, Fin Hex 3/8-16 x 1
22	532127218	Link, Front
23	532124670	Retainer, Spring
24	873350800	Nut, Jam Hex 1/2-13 Unc
25	532130171	Trunnion
26	873800800	Nut, Lock W/Wsh 1/2-13 Unc
29	532150233	Trunnion, Infin Height
30	532110807	Nut, Special
31	819131016	Washer 13/32 x 5/8 x 16 Ga.
32	532137150	Spring, Compression Inf Hgt
33	876020308	Pin, Cotter 3/32 x 1/2
34	532137167	Rod, Adj Lift
35	532138057	Knob, Inf 3/8-16 Unc
38	532155097	Pointer, Height Indicator
39	532123935	Plug, Hole
40	817490512	Screw Thdrol 5/16-18 x 3/4
41	873540600	Nut, Crownlock 3/8-24
42	819112410	Washer 11/32 x 1-1/2 x 10 Ga.
43	532123934	Scale, Indicator Height
70	532145212	Nut Hex Flange Lock
72	532110452	Nut Push Phos & Oil

NOTE: All component dimensions given in U.S. inches
1 inch = 25.4 mm

REPAIR PARTS

TRACTOR - MODEL NO. GTH220 (954140012D), PRODUCT NO. 954 14 00-12

MOWER DECK

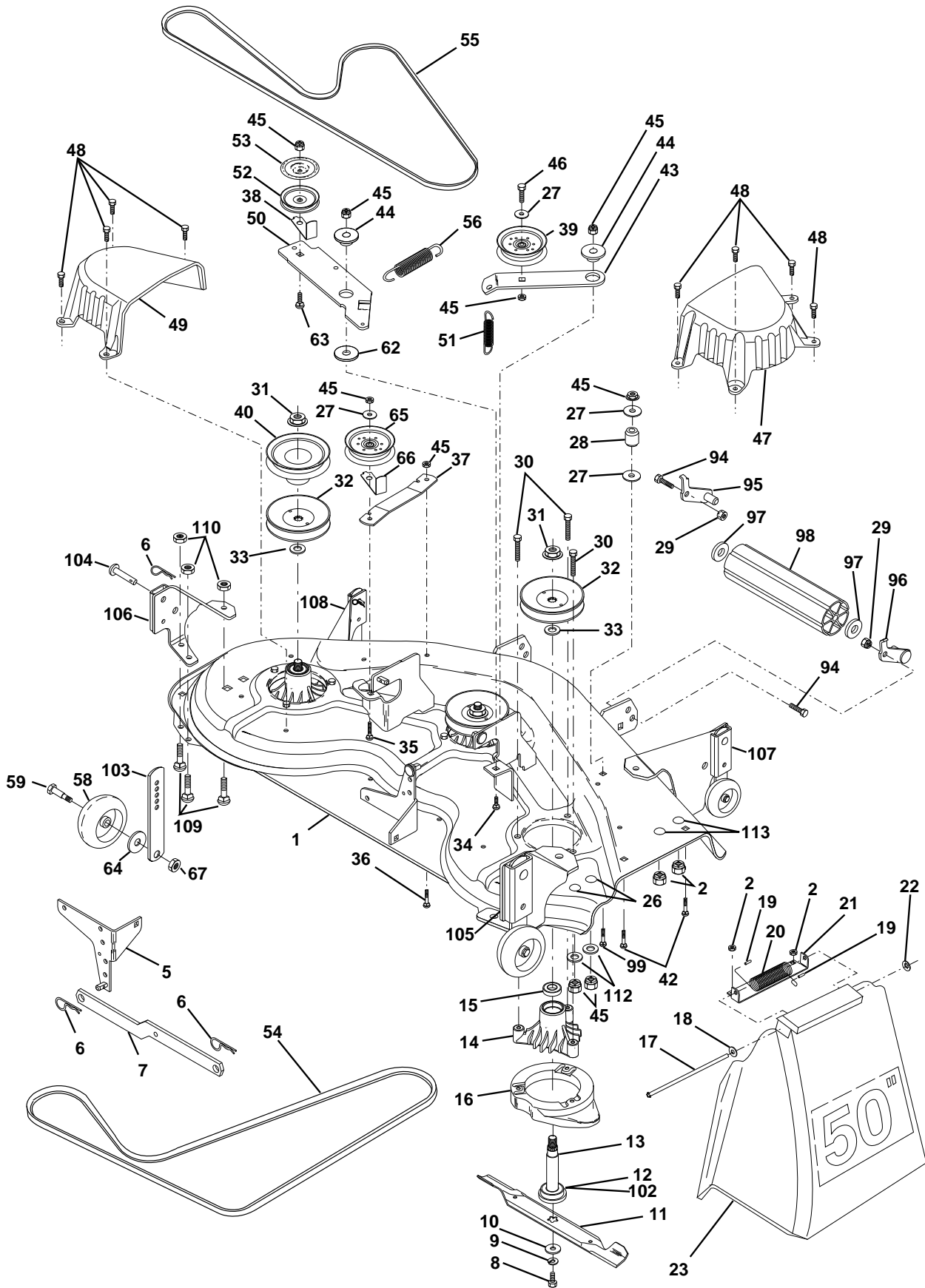

REPAIR PARTS

TRACTOR - MODEL NO. GTH220 (954140012D), PRODUCT NO. 954 14 00-12

MOWER DECK

KEY NO.	PART NO.	DESCRIPTION	KEY NO.	PART NO.	DESCRIPTION
1	532156990	Deck Asm., Mower 50" Vented	49	532136574	Cover, Mandrel LH
2	873680500	Nut, Crownlock 5/16-18 Unc	50	532137272	Arm, Idler Primary
5	532138457	Bracket Asm., Sway Bar	51	532137273	Spring, Secondary
6	532124670	Retainer, Spring	52	532139245	Pulley, Idler V Groove
7	532130832	Arm Suspension, Rear	53	532137789	Shield, Idler
8	532850857	Bolt 3/8-24 x 1.25 Gr. 8 Patched	54	532139573	V-Belt, Mower Primary
9	810030600	Washer, Lock Hvy 3/8 Unplated	55	532144959	V-Belt, Mower Secondary
10	532140296	Washer, Hard Blade Mower Vented	56	532138687	Spring, Primary
11	532137380	Blade (3 Required)	58	532133957	Wheel, Gauge
12	532129895	Bearing, Ball #6204 (Mandrel)	59	532137644	Bolt, Shoulder
13	532137553	Shaft Asm., W/Lower Brg (Includes Key No. 12)	62	532133943	Washer Hardened
14	532137152	Housing, Mandrel 50" Vent	63	872110612	Bolt Carriage 3/8-16 x 1-1/2
15	532110485	Bearing, Ball Mandrel	64	819121414	Washer 3/8 x 7/8 x 14 Ga.
16	532140329	Stripper, Mower Vented	65	532151831	Pulley Idler Flat Mower
17	532106735	Rod, Hinge	66	532156009	Keeper, Belt Idler 44/50" Vent
18	819111016	Washer 11/32 x 5/8 x 16 Ga.	67	873930600	Nut, Center Lock 3/8-16
19	532105304	Cap, Sleeve	94	874760616	Bolt, Fin Hex 3/8-16 UNC x 1
20	532123713	Spring, Torsion Deflector	95	532132274	Bracket, Asm. Noseroller LH
21	532137607	Bracket, Deflector	96	532132273	Bracket, Asm. Noseroller RH
22	532110452	Nut, Push	97	819171416	Washer 17/32 x 7/8 x 16 Ga.
23	532110509	Shield, Deflector Mower	98	532132264	Roller, Nose
27	819131316	Washer 13/32 x 13/16 x 16 Ga.	99	872110614	Bolt, Carriage 3/8-16 x 1-3/4 Gr. 5
28	532132823	Spacer, Spring Stop Idler	102	532153390	Washer Felt
29	873800600	Nut, Lock Hex W/Wsh 3/8-16 Unc	103	532155986	Bar Pnt Adjusting Wheel Gauge
30	532157722	Screw Tdhrolling Washer Head	104	532156941	Pin Head Rivet
31	532137266	Nut, Flg Top Lock Cntr 9/16	105	532156852	Bracket Whl Ga. Asm Rear RH 50"
32	532153535	Pulley, Mandrel	106	632156853	Bracket Whl Ga. Asm. Rear LH 50"
33	532129963	Washer, Spacer Mower Vented	107	532156854	Bracket Whl Ga. Asm. Front RH 50"
34	872140610	Bolt, Carriage 3/8-16 x 1-1/4	108	532156856	Bracket Whl Ga. Asm Front LH 50"
35	872110616	Bolt, Carriage 3/8-16 x 2	109	872010505	Bolt Carriage 5/16-18 x 5/8 Blk
36	872110608	Bolt, Carriage 3/8-16 x 1 Gr. 5	110	873980500	Nut Crownlock 5/16-18 Blk
37	532137166	Stiffener, Arm Idler	111	872110606	Bolt RdHd Sht Sqnk 3/8-16 x 3/4
38	532156085	Keeper, Belt Idler	112	819171216	Washer 17/32 x 3/4 x 16 Ga.
39	532131494	Pulley, Idler Flat	113	872110504	Bolt Carriage 5/16-UNC x 1/2
40	532136572	Pulley, Driven	--	532143651	Mandrel Asm (Includes Key Nos. 8-10, 12-15, 31 and 33)
42	872140506	Bolt, Carriage 5/16-18 Unc x 3/4	--	532158325	Mower Asm Service (Std. Deck - Order separately all Nose Roller and all Gauge Wheel components)
43	532136460	Arm, Idler Secondary			
44	532122052	Spacer, Retainer			
45	873680600	Nut, Crownlock 3/8-16 Unc			
46	874760628	Bolt, Fin Hex 3/8-16 Unc x 1-3/4			
47	532137200	Cover, Mandrel RH			
48	532137729	Screw, Thd Roll 1/4-20 x 5/8			

NOTE: All component dimensions given in U.S. inches
1 inch = 25.4 mm

REPAIR PARTS

TRACTOR - MODEL NO. GTH220 (954140012D), PRODUCT NO. 954 14 00-12
TRANSAXLE HYDRO GEAR MODEL NUMBER 222-3010

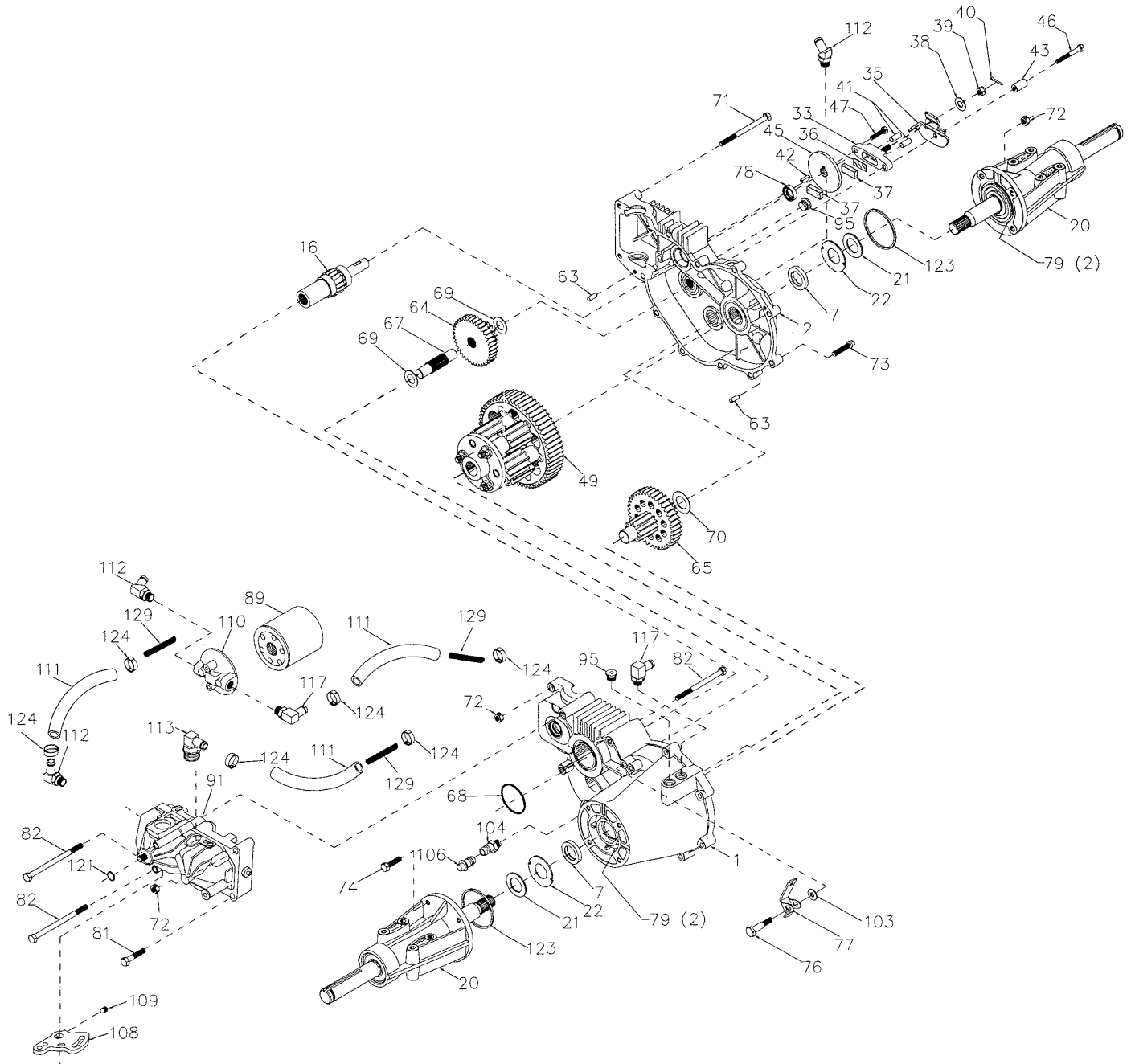

REPAIR PARTS

TRACTOR - MODEL NO. GTH220 (954140012D), PRODUCT NO. 954 14 00-12

TRANSAXLE HYDRO GEAR MODEL NUMBER 222-3010

KEY PART NO. NO.	DESCRIPTION	KEY PART NO. NO.	DESCRIPTION	
1	164591	72	153767	Locknut, Hex 5/16-18
2	164592	73	142904	Bolt, Hex 5/16-18 x 1-1/2
7	153765	74	142905	Hex Cap Screw 5/16-18 x 1
16	142876	76	142907	Shoulder Bolt
20	142877	77	142908	Freewheel Actuating Arm
21	142878	78	142909	Oil Seal .625 x 1.0 x .25
22	142879	79	153768	Grease (10 oz. Tube)
33	142929	81	142910	Bolt, Hex 5/16-18 x 1-3/4
35	142880	82	142911	Bolt 5/16-18 x 4-1/2
36	142882	89	142912	Filter, Spin On
37	142883	91	153769	Pump, BDU-10L-122
38	142884	95	142914	Plug, Straight Thread
39	142885	96	153770	60° 7/18 SAE x 5/16 Fitting
40	142886	103	142916	Washer
41	142887	104	142917	Vent Cap Assembly
42	142888	106	142918	Fitting O-Ring Assembly
43	142889	108	142919	Control Arm
45	142890	109	142920	Set Screw
46	142891	110	142921	Filter Head
47	142892	111	150820	Hose 1/2"
49	153766	112	150823	Fitting, 1/2" Beaded 90° 7/8 SAE
63	142894	113	150821	Fitting, 1/2" Beaded 60° 9/16
64	150818	117	150822	Fitting, 1/2" Beaded 90° 9/16
		123	150824	O Ring
65	142897	124	150825	Pinch Clamp
67	142898	129	153771	Spring, Long
68	142899			
69	142900			
70	142901			
71	142902			

NOTE: All component dimensions given in U.S. inches
1 inch = 25.4 mm

REPAIR PARTS

TRACTOR - MODEL NO. GTH220 (954140012D), PRODUCT NO. 954 14 00-12

TRANSAXLE PUMP- - MODEL NUMBER BDU-10L-122

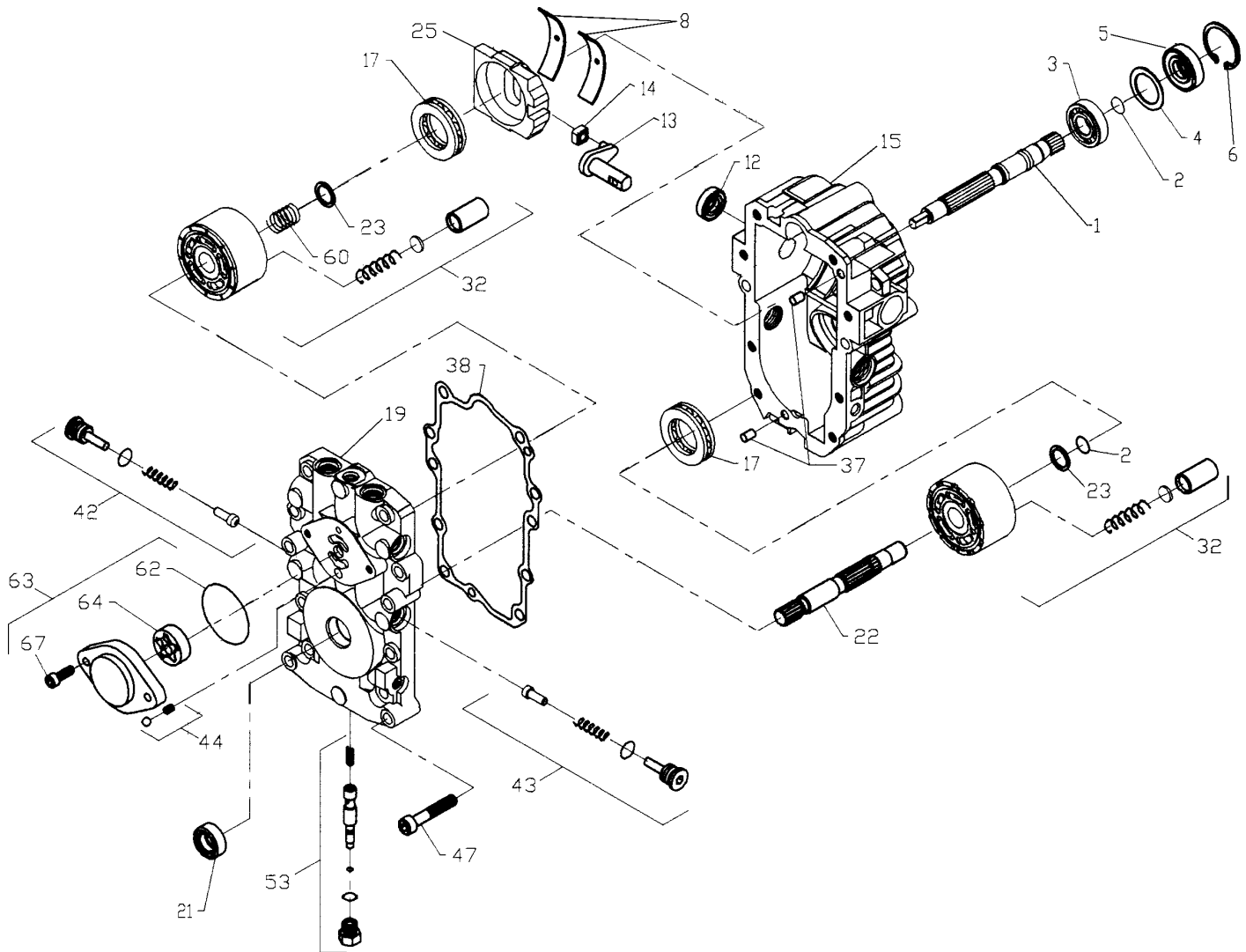

**KEY PART
NO. NO.**

DESCRIPTION

**KEY PART
NO. NO.**

DESCRIPTION

1	532144569	Shaft, Pump
2	532122716	Ring, Retaining
3	532122745	Bearing, Ball
4	532122715	Spacer
5	532122700	Seal, Lip
6	532122699	Ring, Retaining
8	532122767	Bearing, Cradle
12	532122717	Seal, Lip
13	532122748	Arm, Trunnion
14	532122749	Guide, Slot
15	532144571	Housing Kit, Transmission
17	532122770	Bearing, Thrust, Ball
19	532153801	Center Section Kit
21	532122722	Seal, Lip
22	532144573	Shaft, Motor
23	532142978	Washer, Block Thrust

25	532127148	Swashplate, Variable
32	532142938	Block Assembly
37	532122786	Pin, Stainless, Headless
38	532122718	Gasket, Center Section
42	532144578	Check Valve Kit
43	532144578	Check Valve Kit
44	532144579	Charge Relief Kit
47	532122752	Screw, Socket Head, Cap
53	532127153	Bypass Valve Kit
60	532142977	Block Spring
62	532144581	O-Ring
63	532144582	Charge Pump Kit
64	532144583	Gerotor Assembly
67	532144584	Screw, Socket Head, Cap
--	532153769	Pump Assembly, Complete