

YTH 150

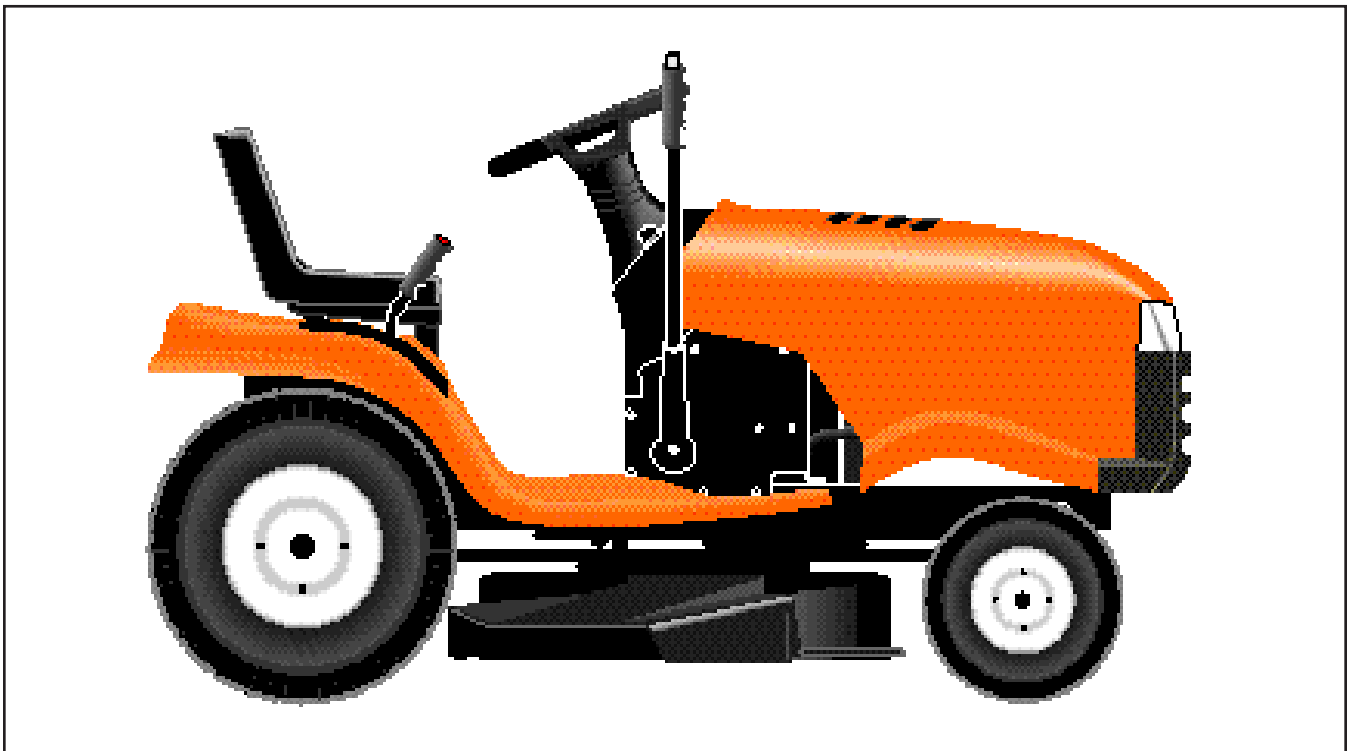

Ride Mower

HCLTH150E

TRACTOR - MODEL NO. YTH150 (HCLTH150E), PRODUCT NO. 954 14 00-07

SCHEMATIC

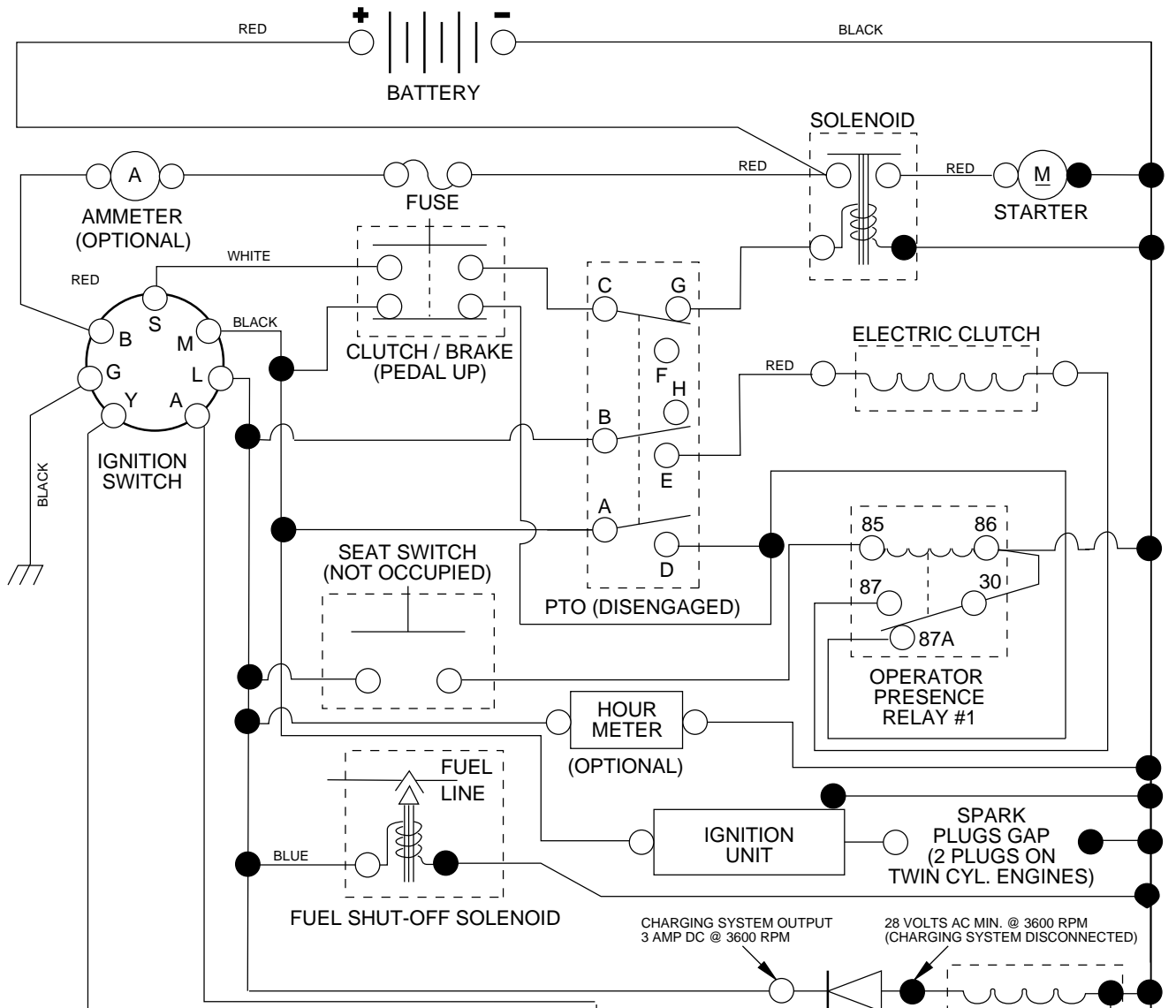

NOTE

YOUR TRACTOR IS EQUIPPED WITH A SPECIAL ALTERNATOR SYSTEM. THE LIGHTS ARE NOT CONNECTED TO THE BATTERY, BUT HAVE THEIR OWN ELECTRICAL SOURCE. BECAUSE OF THIS, THE BRIGHTNESS OF THE LIGHTS WILL CHANGE WITH ENGINE SPEED. AT IDLE THE LIGHTS WILL DIM. AS THE ENGINE IS SPEEDED UP, THE LIGHTS WILL BECOME THEIR BRIGHTEST.

WIRING INSULATED CLIPS
NOTE: IF WIRING INSULATED CLIPS WERE REMOVED FOR SERVICING OF UNIT, THEY SHOULD BE REPLACED TO PROPERLY SECURE YOUR WIRING.

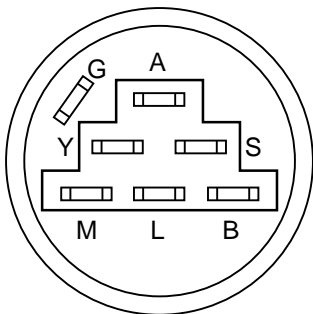

IGNITION SWITCH

POSITION	CIRCUIT	"MAKE"
OFF	G + M + L	NONE
RUN/LIGHT	B + L	A + Y
RUN	B + L	NONE
START	B + L + S	NONE

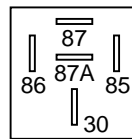

RELAY

POSITION	CIRCUIT
OFF	C + G, B + H
ON	C + F, B + E, A + D

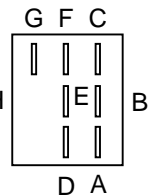

PTO SWITCH

NON-REMOVABLE CONNECTIONS

REMOVABLE CONNECTIONS

REPAIR PARTS

TRACTOR - MODEL NO. YTH150 (HCLTH150E), PRODUCT NO. 954 14 00-07
ELECTRICAL

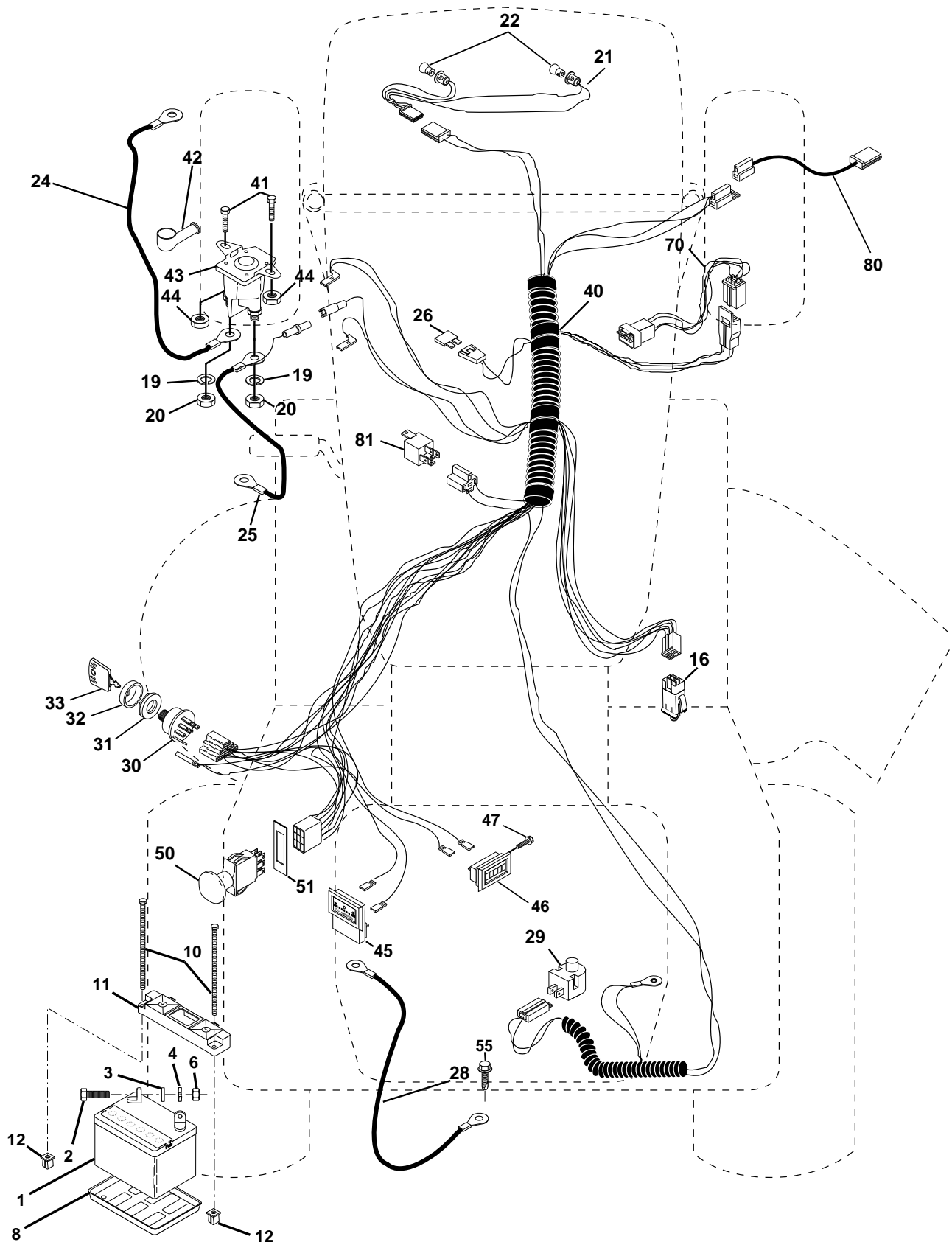

REPAIR PARTS

TRACTOR - MODEL NO. YTH150 (HCLTH150E), PRODUCT NO. 954 14 00-07

ELECTRICAL

KEY NO.	PART NO.	DESCRIPTION
1	532144925	Battery 12 Volt 25 AMP
2	874760412	Bolt Hex Hd 1/4-20unc X 3/4
3	819091016	Washer 9/32 X 5/8 X 16 Ga.
4	810040400	Washer Lock Hvy Helical 1/4
6	873220400	Nut Fin Hex 1/4-20 Unc
8	532124886	Tray Battery 7.80 x 5.25 Blk
10	532145211	Bolt Btr Frt 1/2-20 x 7.5 Zinc
11	532150109	Holddown Battery Front Mount
12	532145769	Nut Push Nylon 1/4" Battery Frt
16	532153664	Switch Interlock Push-In
19	810090400	Washer Lock 1/4
20	873350400	Nut Jam Hex 1/4-20 Unc
21	532136850	Harness Asm Light W/4152j
22	532004152	Bulb Light #1156
24	532124780	Cable Battery 6 Ga 11" red
25	532146148	Cable Battery 6 Ga 44" red w/16 wire
26	532108824	Fuse 30 AMP Auto Green
28	532145491	Cable Ground 6 Ga 21" black
29	532160784	Switch Plunger Normal Op Olive
30	532140301	Switch Ign 4 pos w/lights
31	532124211	Nut Ignition
32	532141226	Cover Sw Ignition
33	532122147	Key Ign Modelled Generic
40	532160719	Harness Ign.
41	871110408	Bolt Blk Fin Hex 1/4 - 20 x 1/2
42	532131563	Cover Terminal Red
43	532145673	Solenoid
44	873640400	Nut Keps Hex 1/4-20 Unc
45	532121433	Ammeter Rectangular 6 Amp
46	532110940	Meter Hour
47	817011008	Screw 10-24 x 1/2 Black
50	532154959	Switch PTO 3PDT Black Delta 96
51	532140405	Ring Retainer PTO
55	817490508	Screw Thdrol 5/16-18 x 1/2 Tyt
70	532142621	Harness, Eng Kohl Cmd-L Dual
80	532146685	Harness Clutch Evx
81	532109748	Relay Asm.

NOTE: All component dimensions given in U.S. inches.
1 inch = 25.4 mm.

REPAIR PARTS

TRACTOR - MODEL NO. YTH150 (HCLTH150E), PRODUCT NO. 954 14 00-07
CHASSIS AND ENCLOSURES

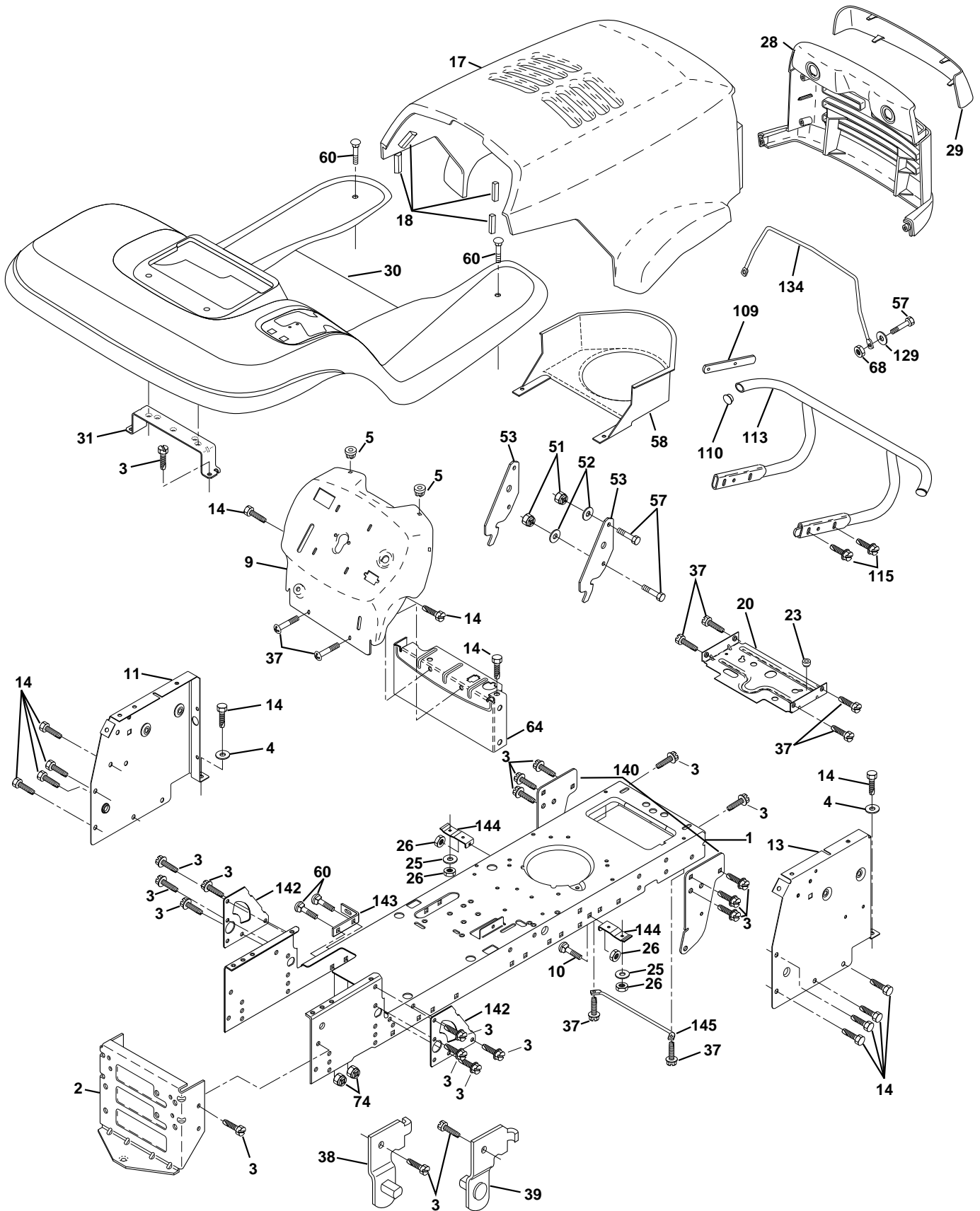

REPAIR PARTS

TRACTOR - MODEL NO. YTH150 (HCLTH150E), PRODUCT NO. 954 14 00-07

CHASSIS AND ENCLOSURES

KEY NO.	PART NO.	DESCRIPTION
1	532160392	Chassis Weldment
2	532140356	Drawbar, Stretch
3	817490612	Screw Thdrol 3/8-16x3/4 Ty-tt
4	819131216	Washer 13/32 x 3/4 x 16 Ga.
5	532155272	Bumper Hood/Dash
9	532156490	Dash Silkscr.Plm.E.A.Hm.Nc.Sym
10	872140608	Bolt Carriage 3/8-16 x 1
11	532155927	Panel Dash Lh
13	532153913	Panel Dash Rh
14	817490608	Screw Thdrol 3/8-16x1/2 Ty-tt
17	532156051	Hood LT/PL Husqvarna
18	532126938	Bumper Hood
20	532156437	Plate Mtg Battery Fuel Tank Fr
23	532124028	Bushing
25	819131312	Washer 13/32 X 13/16 X 12 Ga
26	873800600	Nut Lock Hex W/Ins 3/8-16 Unc
28	532149776	Grille LT/PL Husqvarna
29	532149777	Lens LT/PL Husqvarna
30	532156489	Fender Footrest STLT Pnt
31	532139976	Bracket Support Fender
37	817490508	Screw Thdrol 6/16-18 x 1/2 TYT
38	532139886	Bracket, Asm. Pivot, L.H., Mower Rear
39	532139887	Bracket, Asm. Pivot, R.H., Mower Rear
51	873800400	Nut Lock Hex W/Ins 1/4-20
52	819091416	Washer 9/32 x 7/8 x 16 Ga.
53	532150067	Bracket Pnt. Pick off LT/PL Husqvarna
57	874780412	Bolt Hex 1/4-20 x 3/4
58	532150127	Air Duct Engine P/L
60	872140606	Bolt Rdhd Sqnk 3/8-16unc x 3/4
64	532154798	Dash Lower STLT
68	873510400	Nut Keps Hex 1/4-20unc
74	873680600	Nut Crownlock 3/8-16 UNC
109	532141461	Bracket Extension Bumper
110	532143679	Plug Plastic
113	532150300	Bumper Asm.
115	817490620	Screw Thdrol 3/8-16 x 1-1/4
129	819091016	Washer 9/32 x 5/8 x 16 Ga.
134	532160219	Rod Support Hood LT/PL Husq.
140	532158418	Bracket Suspension Front
142	532156095	Plate Reinforcement STLT
143	532154966	Bracket Swaybar Chassis
144	532154207	Bracket Pnt Footrest STLT
145	532156524	Rod Pivot Chassis/Hood

NOTE: All component dimensions given in U.S. inches
1 inch = 25.4 mm

REPAIR PARTS

TRACTOR - MODEL NO. YTH150 (HCLTH150E), PRODUCT NO. 954 14 00-07

DRIVE

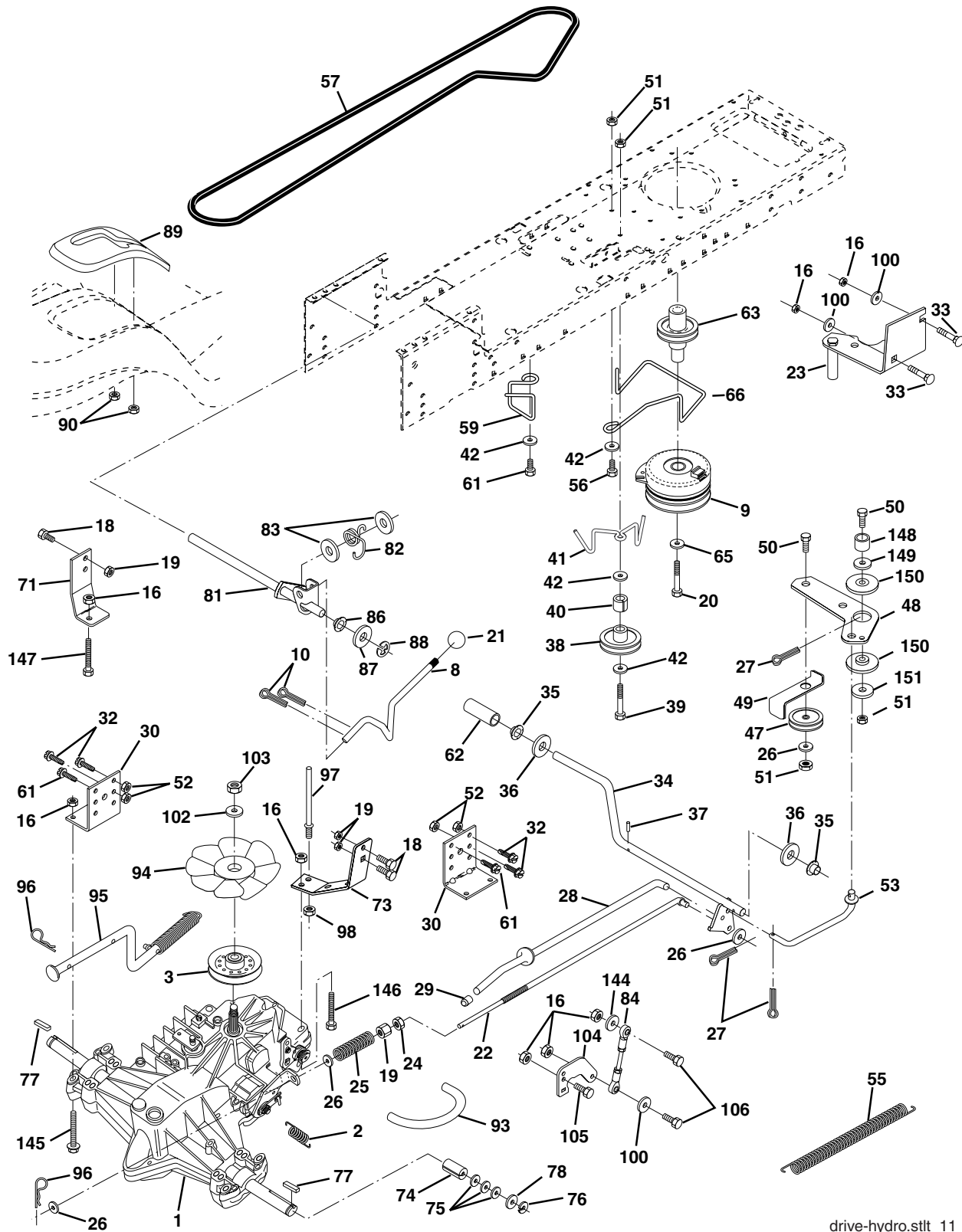

drive-hydro.stlt_11

REPAIR PARTS

TRACTOR - MODEL NO. YTH150 (HCLTH150E), PRODUCT NO. 954 14 00-07

DRIVE

KEY PART NO.	PART NO.	DESCRIPTION	KEY PART NO.	PART NO.	DESCRIPTION
1	532150071	Transaxle w/cas Hydro 310-0650	63	532161400	Pulley, Engine
2	532142431	Spring, Return, Brake	65	810040700	Washer Lock Hvy HLCL Spr 7/16
3	532143995	Pulley, Transaxle Hydro 750 LT	66	532161488	Keeper Belt Engine
8	532154792	Rod Shift STLT	73	532156347	Strap Torque Rh Hydro 0650
9	532145028	Clutch Electric	71	532140158	Strap Torque Lh Hydro 18/20" T
10	876020416	Pin Cotter 1/8 x 1 CAD	74	532121199	Spacer, Split
16	873800500	Nut Lock Hex W/Ins. 5/16-18 Unc P	75	532121749	Washer 25/32 x 1-1/4 x 16 Ga.
18	874780616	Bolt Fin Hex 3/8-16 Unc x 1 Gr.5	76	812000001	E-Ring
19	873800600	Nut Lock Hex W/Ins 3/8-16 Unc	77	532123583	Key, Square
20	532150280	Bolt, Hex 7/16-20 x 4-1/4 Ga. 5	78	532121748	Washer 25/32 x 1-5/8 x 16 Ga
21	532140845	Knob Deluxe 1/2-13 UNC BLK/BLK	81	532156046	Shaft Asm. Cross Hydro 20" Tires
22	532145627	Rod, Brake Hydro	82	532123782	Spring Torsion T/A
23	532154978	Bracket Asm Mtg CL	83	819171216	Washer 17/32 x 3/4 x 16 Ga.
24	873350600	Nut Hex Jam 3/8-16 UNC	84	532161901	Rod, Tie Hydro 20" Tires SPH Ball 4.50
25	532106888	Spring, Brake Rod	86	532157480	Bushing
26	819131316	Washer	87	819212016	Washer 21/32 x 1-1/4 x 16 Ga.
27	876020412	Pin Cotter 1/8 x 3/4 CAD.	88	812000008	Ring Klip #5304-62
28	532145204	Rod, Parking Brake	89	532158388	Console, Hydro Shift Stlt
29	532071673	Cap, Parking Brake	90	532124346	Nut Self-Thd Wsh-Hd 1/4 Zinc
30	532130807	Bracket, Transaxle	93	532142564	Line Fuel Hydro 4"
32	874760512	Bolt Hex Hd 5/16-18 Unc x 3/4	94	532140462	Fan, Hydro 7"
33	872140506	Bolt Carriage 5/16-18 UNC x 3/4	95	532144643	Control Asm. Bypass Hydro
34	532155071	Shaft, Foot Pedal	96	532124788	Retainer Spring 1" Zinc/Cad
35	532120183	Bearing, Nylon	97	532140469	Keeper Belt Rh Hydro 0750.18/20"
36	819211616	Washer	98	873510600	Nut Keps Hex 3/8-16 Unc
37	532124963	Pin, Roll	100	819111216	Washer 11/32 x 3/4 x 16 Ga.
38	532131494	Pulley, Idler, Flat	102	532141322	Washer Belleville .501D x 1.50D
39	874760644	Bolt	103	873940800	Nut Hex Jam Toplock 1/4-20 Unf
40	532124965	Spacer Split	104	532140156	Arm, Control Hydro
41	532165838	Keeper, Belt Idler	105	871070516	Screw Cap Hex 5/16 x 18 x 1
42	819131312	Washer 13/32 x 13/16 x 12 Ga	106	874780520	Bolt Fin Hex 5/16-18 Unc x 1-1/4
47	532127783	Pulley, Idler, V-Groove Plastic	144	819111016	Washer 11/32 x 5/8 x 16 Ga.
48	532154407	Bellcrank Clutch Grnd	145	874490540	Bolt Hex Flghd 5/16-18 x Gr. 5
49	532123205	Retainer, Belt Style Spring	146	874490536	Bolt Hex Flanged 5/16-18 Unc x 2
50	874760624	Bolt	147	874490524	Bolt Hex Flanged 5/16-18 Unc x 2
51	873680600	Nut	148	532159103	Spacer
52	873680500	Nut Crown Lock 5/16-18	149	532122052	Spacer Retainer PM Mower
53	532105710	Link, Clutch	150	532150935	Bushing Nylon Collared
55	532105709	Spring, Return, Clutch	151	819133210	Washer 13/32 x 2 x 10 Ga.
56	874760620	Bolt, Fin Hex 3/8-16 UNC x 1 1/4			
57	532161588	V-Belt, Ground Drive			
59	532140312	Keeper, Center Span			
61	817490612	Screw Thdrol. 3/8-16 x 3/4 Ty. TT			
62	532123533	Cover, Pedal Premium			

NOTE: All component dimensions given in U.S. inches
1 inch = 25.4 mm

REPAIR PARTS

TRACTOR - MODEL NO. YTH150 (HCLTH150E), PRODUCT NO. 954 14 00-07

STEERING ASSEMBLY

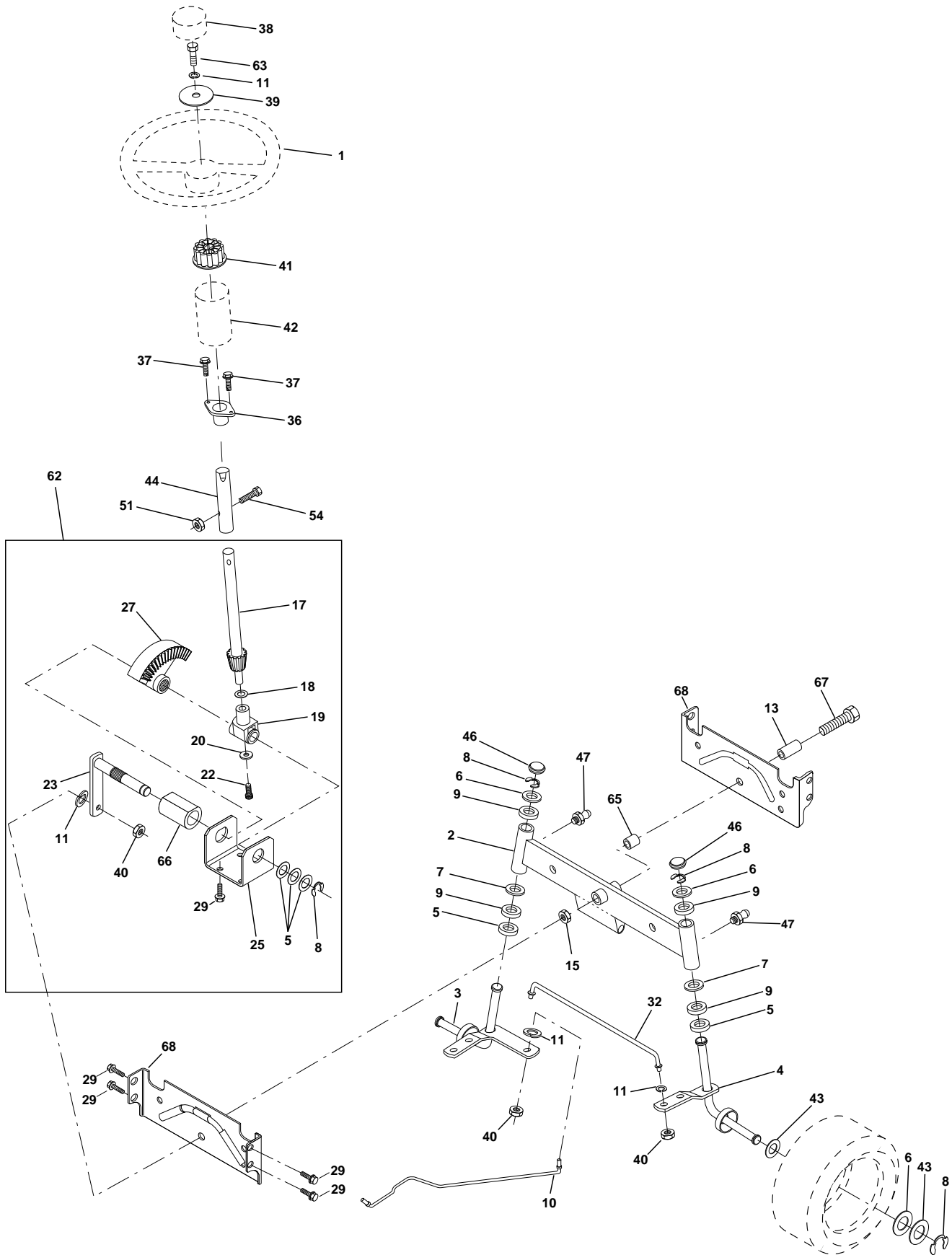

REPAIR PARTS

TRACTOR - MODEL NO. YTH150 (HCLTH150E), PRODUCT NO. 954 14 00-07

STEERING ASSEMBLY

KEY NO.	PART NO.	DESCRIPTION
1	532124415	Wheel Steering
2	532137094	Axle Front Casting Machined
3	532157479	Spindle Asm LH
4	532157478	Spindle Asm RH
5	532124931	Bearing Race Thrust Harden
6	532121748	Washer 25/32 X 1-5/8 X 16 Ga
7	819272016	Washer 27/32 X 1-1/4 X 16 Ga
8	812000029	Ring Klip #t5304-75
9	532124937	Bearing Col Strg Blk
10	532154432	Link Drag Extended Cast
11	810040600	Washer Lock Hvy Hlcl Spr 3/8
13	532154779	Bearing Axle STLT/GT
15	873901000	Nut Lock Flange 5/8-11 Unc
17	532156546	Shaft Asm Strg
18	532057079	Washer Thrust 515x 750x 033
19	532124035	Support Shaft
20	532126684	Washer Shim 1/4 X 5/8 X 062
22	871200410	Screw Hex Sckt 1/4-20 x 5/8
23	532127501	Shaft Asm Pittman
25	532154406	Bracket Steering
27	532136874	Gear Sector
29	817490612	Screw Thdrol 3/8-16x3/4 Ty-tt
32	532137347	Rod Asm Tie Ball Adj. VGT
36	532155099	Bushing Strg
37	532152927	Screw
38	532124416	Insert Cap Strg Wh Au
39	819133808	Washer 13/32 X 2-3/8 X 8 Ga
40	532124701	Lock nut
41	532100711	Adaptor Wheel Strg
42	532155092	Boot Steering Shaft
43	532121749	Washer 25/32 X 1 1/4 X 16 Ga
44	532153720	Extension Steering Shaft LR/LT
46	532121232	Cap Spindle Fr Top Blk
47	532124836	Fitting Grease
51	873800500	Nut Lock Hex w/Ins 5/16-18
54	874780520	Bolt Fin Hex 5/16-18 Unc x 1-1/4
62	532156594	Kit, Steering Assembly Svc
63	874780616	Bolt Fin Hex 3/8-16unc x 1 Gr. 5
65	532154780	Spacer Axle
66	532154404	Bearing Arm Pittman
67	874781044	Bolt, Fin Hex 5/8-11 UNC x 2-3/4
68	532154429	Brace, Axle

NOTE: All component dimensions given in U.S. inches.
1 inch = 25.4 mm.

REPAIR PARTS

TRACTOR - MODEL NO. YTH150 (HCLTH150E), PRODUCT NO. 954 14 00-07

SEAT ASSEMBLY

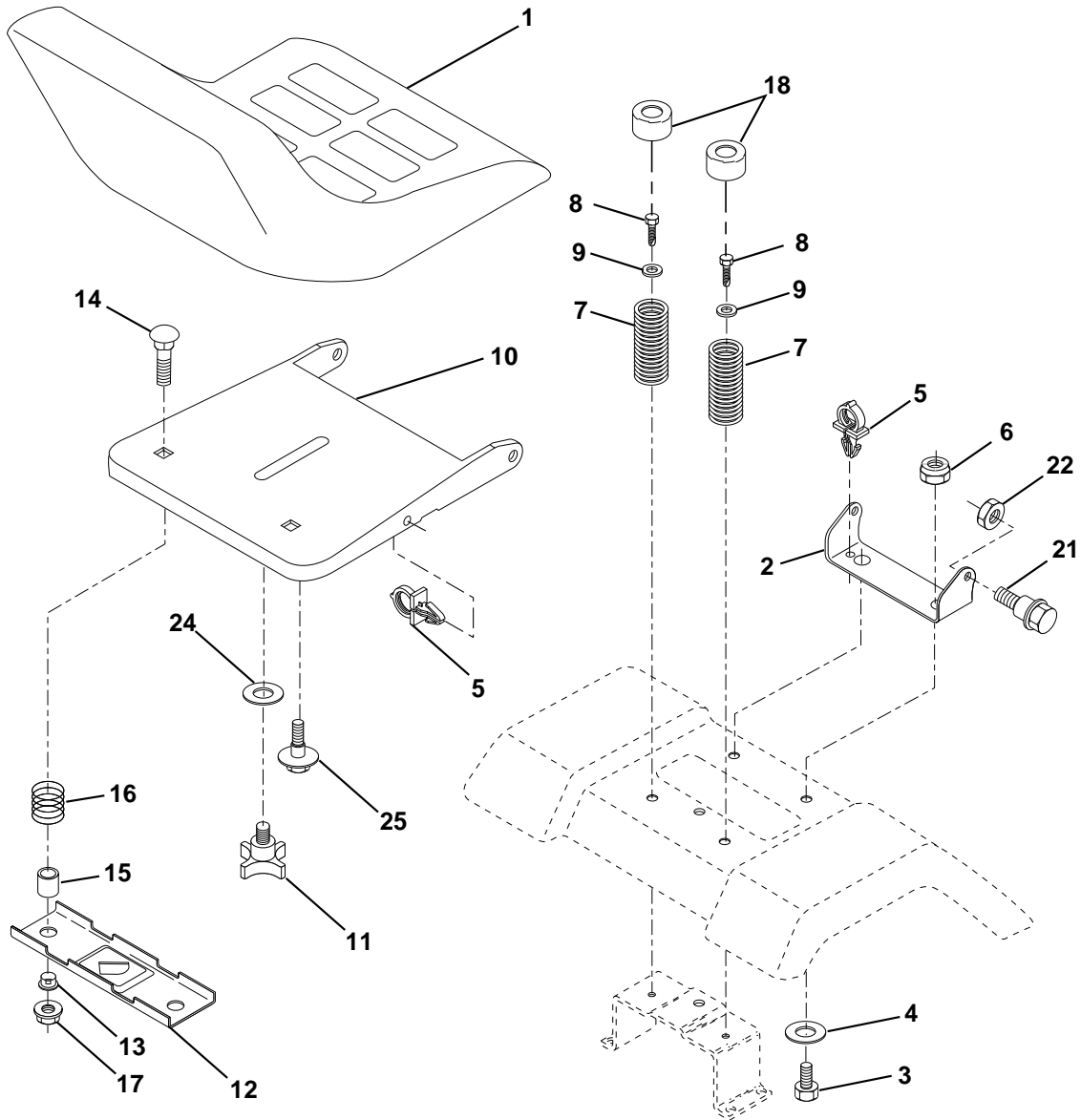

KEY PART NO. NO.

DESCRIPTION

1	532140839	Seat
2	532140551	Bracket Pivot Seat 8 720
3	874760616	Bolt Fin Hex 3/8-16unc X 1
4	819131610	Washer 13/32 X 1 X 10 Ga
5	532145006	Clip Push-In
6	873800600	Nut Hex w/Ins. 3/8-16 Unc
7	532124181	Spring Seat Cprsn 2 250 Blk Zi
8	817490616	Screw Thdrol 3/8-16 X 1 Ty-tt
9	819131614	Washer 13/32 X 1 X 14 Ga.
10	532155925	Pan Seat
11	532120068	Knob Seat 1/2-13 Unc Blk
12	532121246	Bracket Mounting Switch

KEY PART NO. NO.

DESCRIPTION

13	532121248	Bushing Snap Blk Nyl 50 Id
14	872050412	Bolt Rdhd Sqnk 1/4-20x1-1/2
15	532134300	Spacer Split 28x 96 Yel Zinc
16	532121250	Spring Cprsn 1 27 Blk Pnt
17	532123976	Nut Lock 1/4 Lge Flg Gr 5 Zinc
18	532124238	Cap Spring Seat
21	532153236	Bolt Shoulder 5/16-18 Unc
22	873800500	Nut Hex Lock W/Ins 5/16-18
24	819171912	Washer 17/32 X 1-3/16 X 12 Ga.
25	532127018	Bolt Shoulder 5/16-18 X 62

NOTE: All component dimensions given in U.S. inches.
1 inch = 25.4 mm

REPAIR PARTS

TRACTOR - MODEL NO. YTH150 (HCLTH150E), PRODUCT NO. 954 14 00-07

DECALS

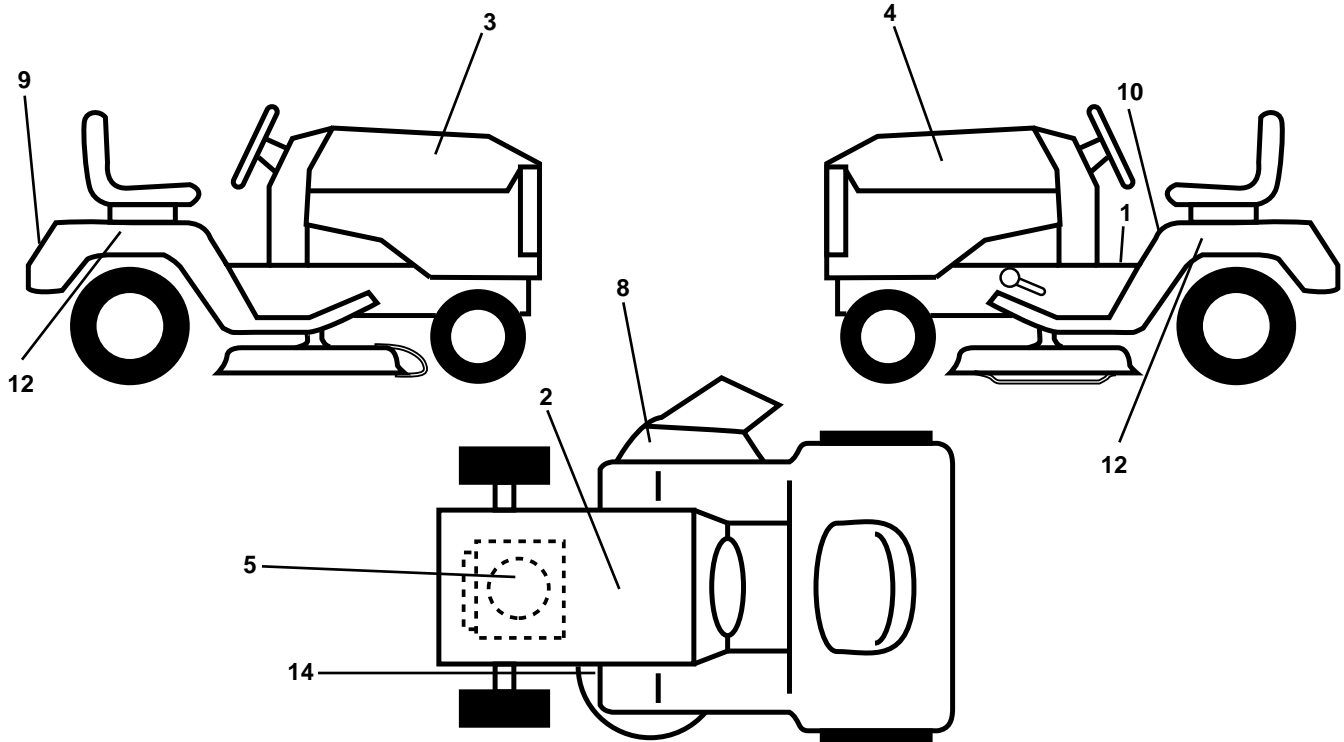

KEY NO.	PART NO.	DESCRIPTION
1	532157032	Decal Oper. Step Thru E/F
2	532145005	Decal Battery
3	532150729	Decal Hood RH
4	532150730	Decal Hood LH
5	532151244	Decal HP Engine
8	532137259	Decal Warning Multi-Languages
9	532150617	Decal Fender Husq
10	532157140	Decal Fender Danger E/F
12	532157007	Decal Fender Auto Husq Radius
14	532160396	Decal V-Belt Schematic
--	532154515	Pad Footrest LH STLT
--	532142341	Decal Drawbar Cntrl Mvt Hyd LT

KEY NO.	PART NO.	DESCRIPTION
--	532154516	Pad Footrest RH STLT
--	532138311	Decal Handle Lft Height Adjust
--	532162559	Manual Owner's (English)
--	532162560	Manual Owner's (French)
Available accessories not included with tractor:		
--	MK420	Mulcher Kit with Blades
--	C42	Grass Catcher
--	LSB42	42" Snow Blower
--	LC05	Wheel Wts. (Pair)
--	LC06	Tire Chains 20 x 10 x 8
--	LBD48	48" Snow Blade

WHEELS & TIRES

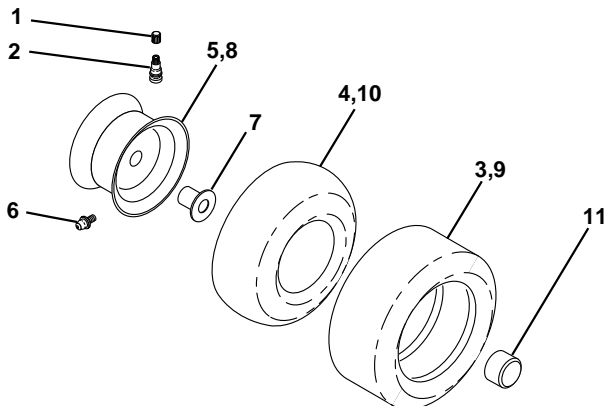

KEY NO.	PART NO.	DESCRIPTION
1	532059192	Cap Valve Tire
2	532065139	Stem Valve
3	532106222	Tire F Ts 15 X 6 0 - 6 Service
4	532059904	Tube Front (Service Item Only)
5	532138336	Rim Asm 6"front Silver Service
6	532124957	Fitting Grease (Front Wheel Only)
7	532124959	Bearing Flange (Front Wheel Only)
8	532138337	Rim Asm 8"rear Silver Service
9	532122082	Tire R Ts 20x10-8 C Service
10	532124926	Tube Rear (Service Item Only)
11	532104757	Cap Axle Blk 1 50 X 1 00
--	532144334	Sealant, Tire (10 oz. Tube)

NOTE: All component dimensions given in U.S. inches
1 inch = 25.4 mm

REPAIR PARTS

TRACTOR - MODEL NO. YTH150 (HCLTH150E), PRODUCT NO. 954 14 00-07
ENGINE

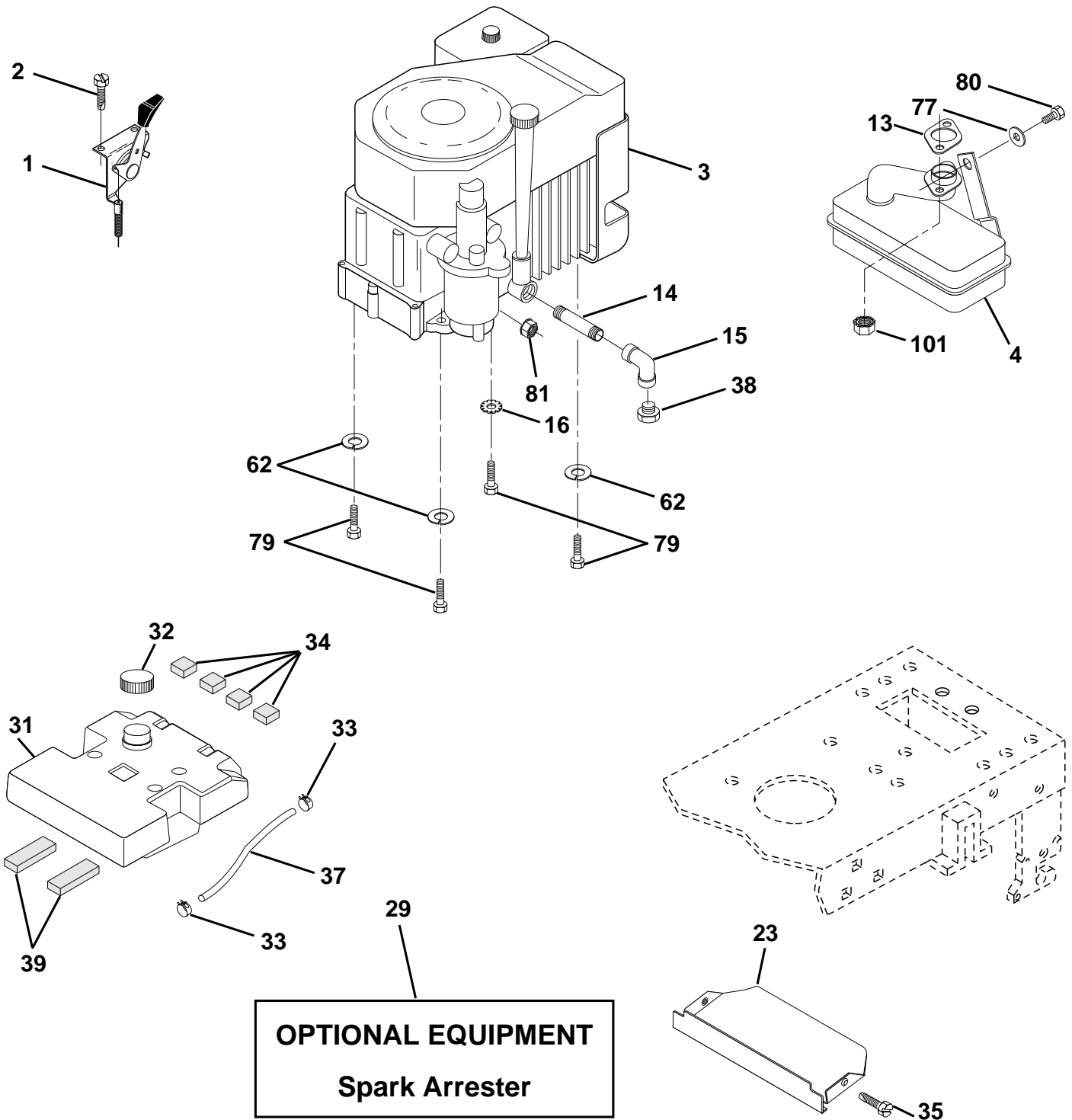

REPAIR PARTS

TRACTOR - MODEL NO. YTH150 (HCLTH150E), PRODUCT NO. 954 14 00-07

ENGINE

KEY NO.	PART NO.	DESCRIPTION
1	532141296	Control Th/ch 27. LH. Flag Dom.
2	817720410	Screw Hex Thd Cut 1/4-20x5/8 T
3	-----	Engine Kohler Model No. CV15s
4	532137350	Muffler LT Kohler 12.5/15HP
14	813280328	Nipple Pipe 3/8 Npt X 3-1/2
15	813200300	Elbow Std 90 Degree 3/8-18 Npt
16	811050500	Washer Lock Ext Tooth 5/16
23	532159880	Shield Browning/Debris Guard
29	532137180	Kit Spark Arrestor (Flat Scrn)
31	532157103	Tank Fuel 3.5 STLT W/O Sensor
32	532140527	Cap Asm Fuel W/sym Vented
33	532123487	Clamp Hose Black
34	532106082	Pad Spacer
35	817490512	Screw
37	532124923	Line Fuel 7.5"
38	-----	Plug Oil Drain (Order From Engine Manufacturer)
39	532109227	Pad Idler 1.75 x .75 x .06
40	532124952	Bushing
41	532139277	Stem Tank Fuel
62	810040500	Washer Lock Hvy Hlcl Spr 5/16
77	819101216	Washer 5/16 x 3/4 x 16 Ga.
79	532125398	Bolt Hex
80	874760508	Bolt Hex Hd. 5/16-18unc x 1/2
81	532128861	Nut Flange 1/4-20 Starter Nut

NOTE: All component dimensions given in U.S. inches
1 inch = 25.4 mm

REPAIR PARTS

TRACTOR - MODEL NO. YTH150 (HCLTH150E), PRODUCT NO. 954 14 00-07
MOWER DECK

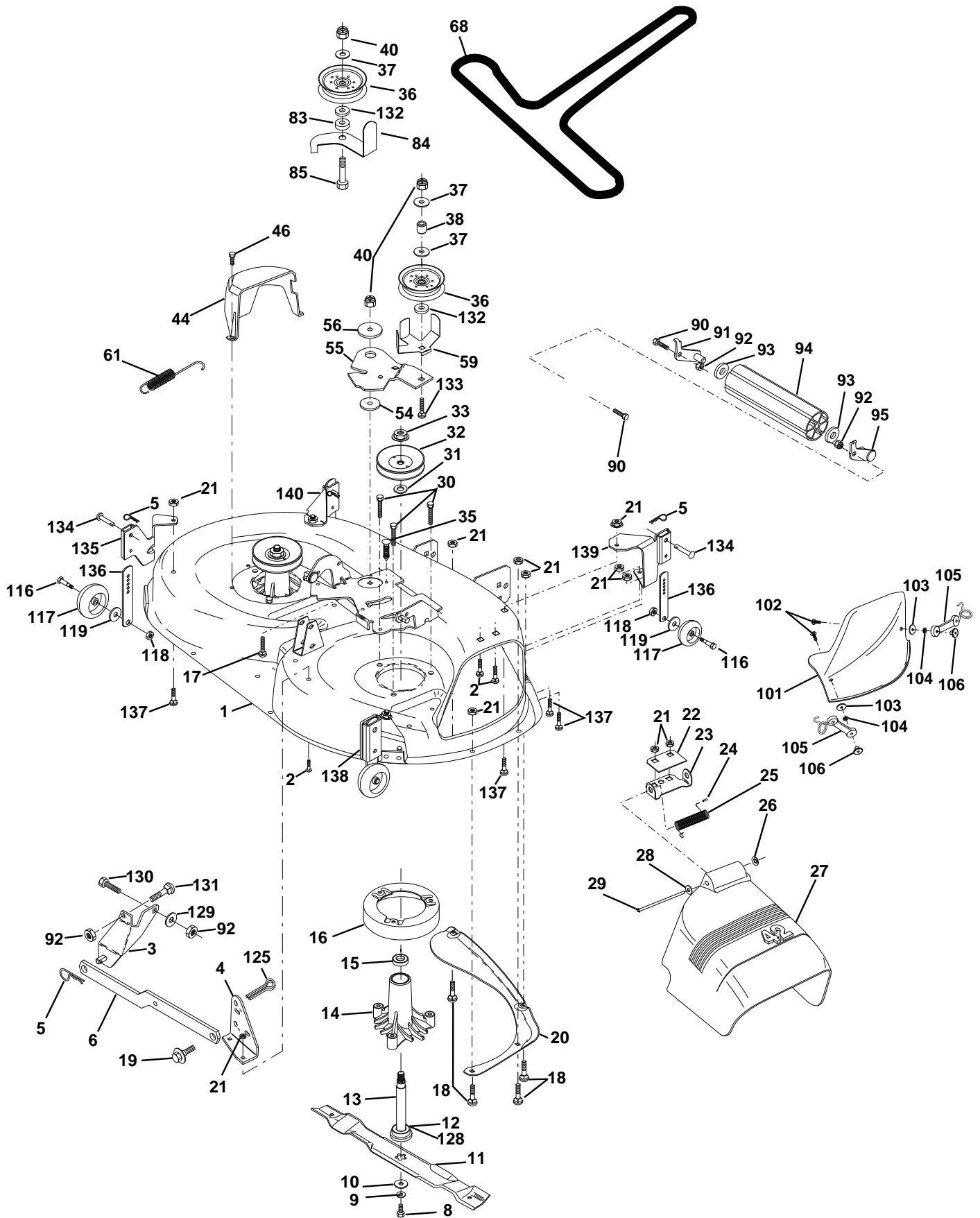

REPAIR PARTS

TRACTOR - MODEL NO. YTH150 (HCLTH150E), PRODUCT NO. 954 14 00-07

MOWER DECK

KEY NO.	PART NO.	DESCRIPTION	KEY NO.	PART NO.	DESCRIPTION
1	532162809	Housing Asm Mower 42"w/aadj	68	532144959	V-Belt Mower
2	872140506	Bolt Rdhd Sqnc 5/16-18unc X3/4	83	532120958	Washer Sintered
3	532138017	Bracket Asm Fr Sway Bar 38/42	84	532156084	Keeper 'Belt Idler
4	532138440	Bracket Asm Deck 42"sway Bar	85	872140618	Bolt Carriage 3/8-16 x 2-1/4 Gr.5
5	532124670	Retainer Spring	90	874760616	Bolt Fin Hex 3/8-16unc X 1
6	532130832	Arm Suspension Rear	91	532132274	Bracket Asm Noseroller LH
8	532850857	Bolt 3/8-24x1 25 Gr8 Patched	92	873800600	Nut Lock Hex w/ins. 3/8-16 UNC
9	810030600	Washer Lock Hvy 3/8 Unplated	93	819171416	Washer 17/32 X 7/8 X 16 Ga
10	532140296	Washer Hard Blade Mower Vented	94	532132264	Roller Nose 38 & 42
11	532134149	Blade Mower Mulching 42"	95	532132273	Bracket Asm Noseroller RH
12	532129895	Bearing Ball #6204 (Mandrel)	101	532136420	Cover Mulching 42" Blk
13	532137645	Shaft Asm W/lower Bearing	102	871161010	Screw
14	532128774	Housing Mandrel Vented(machd)	103	819061216	Washer #10
15	532110485	Bearing Ball Mandrel	104	810071000	Washer Lock #10
16	532140329	Stripper Round Mower	105	532160793	Latch Asm Bagger
17	872110618	Bolt Rdhd Sqnc 3/8-16 X 2-1/4	106	532125004	Nut Weld .327/.304 #10-24
18	872140505	Bolt Carr 5/16-18 X 5/8	116	532137644	Bolt Shld
19	532132827	Bolt Shoulder	117	532133957	Wheel Gauge Donut
20	532159770	Baffle Vortex 42	118	873930600	Nut Centerlock 3/8 - 16 UNC
21	873680500	Nut Crown Lock 5/16-18	119	819121414	Washer 3/8 x 7/8 x 14 Ga.
22	532134753	Stiffener Bracket 42"deck	125	876020816	Cotter Pin
23	532131267	Bracket Deflector Mower 42"	128	532153390	Washer Felt
24	532105304	Cap Sleeve 80x 112 Blk Mower	129	819131312	Washer 13/32 x 13/16 x 12 Ga.
25	532123713	Spring Torsion Deflector 2 52	130	874780616	Bolt Fin Hex 3/8-16unc x 1 Gr. 5
26	532110452	Nut Push Phos & Oil	131	872140608	Bolt Rdhd Sqnc 3/8-16 UNC
27	532130968	Shield Deflector Mower 42" Blk	132	819132203	Washer 13/32 x 1-3/8 x 3 Ga.
28	819111016	Washer 11/32 X 5/8 X 16 Ga	133	872110622	Bolt RDHD 3/8-16 Unc x 2-3/4 Gr.5
29	532131491	Rod Hinge 42"6 75 Wlg	134	532156941	Pin Head Rivet
30	532157722	Screw Thdrol Washer Head	135	532159765	Bracket Asm Whl Ga Rear Lh 42"
31	532129963	Washer Spacer Mower Vented	136	532155986	Bar Adjusting Gauge Wheel
32	532153535	Pulley Mandrel 42"	137	872110505	Bolt Caarr. 5/16-18 x 5/8 Short
33	532137266	Nut 9/16top Lock Flng Cntr	138	532159763	Bracket Asm Whl Ga Rear Rh 42
35	532133835	Fastner Christmas Tree	139	532159767	Bracket Asm Whl Ga Front Rh 42
36	532131494	Pulley Idler Flat 3 060	140	532159768	Bracket Asm Whl Ga Front Lh 42
37	819131316	Washer 13/32 X 13/16 X 16 Ga	--	532162859	Deck Serv 42" Elec Vent (Standard Deck - Order Nose Roller, Gauge Wheel and Mulcher Plate components separately Key Nos. 90-95, 101-106, 116-119, and 134-140)
38	532132823	Spacer Spring Stop Idler	--	532130794	Mandrel Assembly (Includes Key Numbers 8-10, 12-15, 31 and 33)
40	873680600	Nut Lock 3/8-16 Unc			
44	532140088	Guard Mandrel LH Black			
46	532137729	Screw Thdrol 1/4-20x5/8			
54	532133943	Washer Hardened			
55	532140084	Arm Idler 42"mower LT/YT			
56	532122052	Spacer Retainer Pm Mower			
59	532141043	Guard, Belt			
61	532131950	Spring Ext. Elect			

NOTE: All component dimensions given in U.S. inches
1 inch = 25.4 mm

REPAIR PARTS

TRACTOR - MODEL NO. YTH150 (HCLTH150E), PRODUCT NO. 954 14 00-07
MOWER LIFT

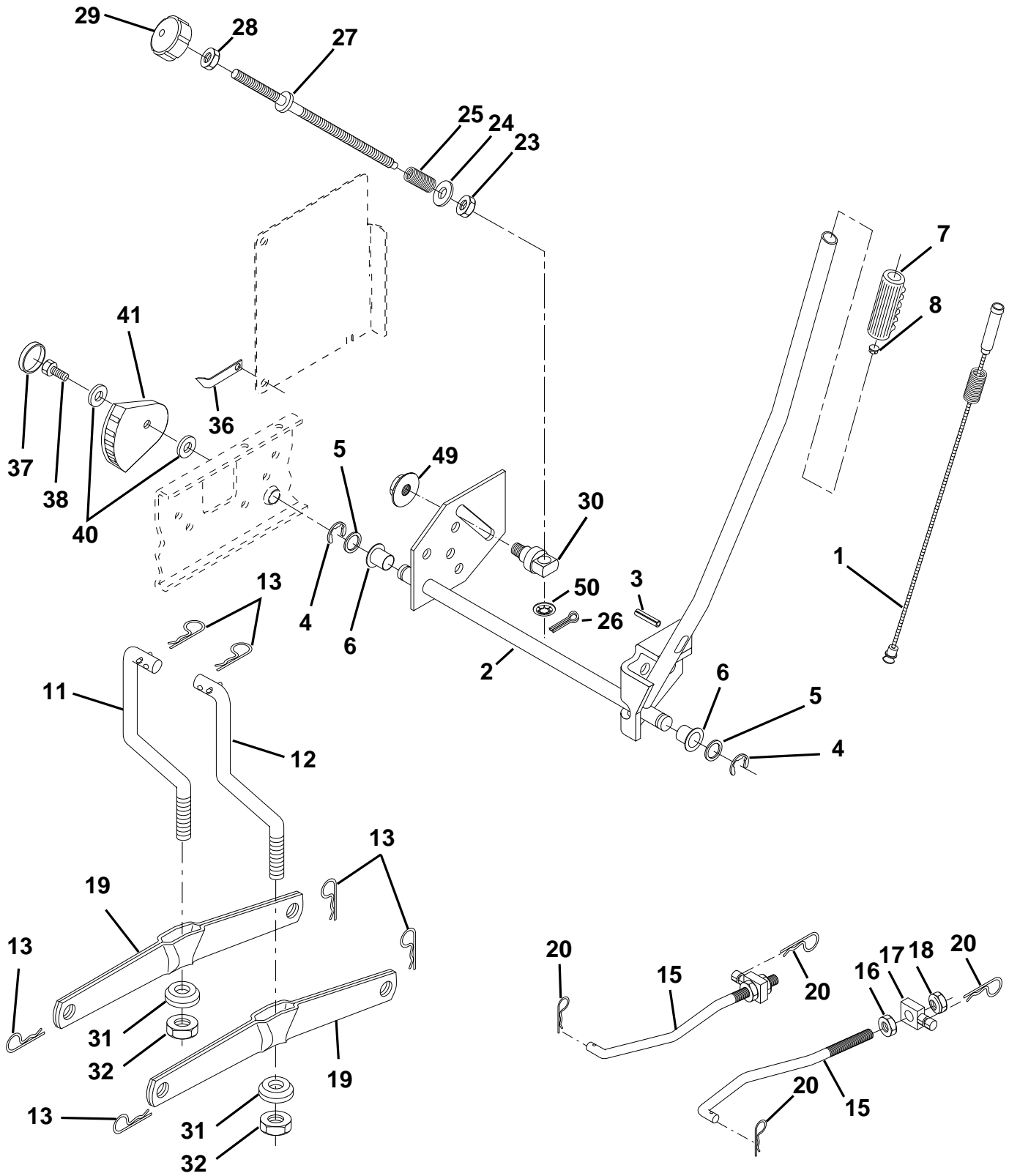

REPAIR PARTS

TRACTOR - MODEL NO. YTH150 (HCLTH150E), PRODUCT NO. 954 14 00-07

MOWER LIFT

KEY NO.	PART NO.	DESCRIPTION
1	532159460	Wire Asm Inner W/plunger
2	532159471	Shaft Asm Lift RH w/Inf
3	532105767	Pin Groove 1 500 Zinc
4	812000002	E Ring #5133-62
5	819211621	Washer 21/32 X 1 X 21 Ga
6	532120183	Bearing Nylon Blk 629 Id
7	532125631	Grip Handle Fluted Blk
8	532124526	Button Plunger Black
11	532139865	Link Lift LH Fixed Length
12	532139866	Link Lift RH Fixed Length
13	532124670	Retainer Spring
15	532127218	Link Front
16	873350800	Nut Jam Hex 1/2-13 Unc
17	532130171	Trunnion Blk Zinc
18	873800800	Nut Lock W/wsh 1/2-13unc
19	532139868	Arm Suspension Rear
20	532124660	Retainer Spring
23	532110807	Nut Special
24	819131016	Washer 13/32 X 5/8 X 16 Ga
25	532124874	Spring 2-1/8"
26	876020308	Pin Cotter 3/32 X 1/2
27	532126971	Rod Adj Lift Zinc 7.49 Wrk Lg
28	873350600	Nut Hex Jam 3/8-16 Unc
29	532138057	Knob Inf 3/8-16 Unc Blk W/sym
30	532150233	Trunnion Infin Height
31	532140302	Bearing Pvt Lift Spherical
32	873540600	Nut Crownlock 3/8 - 24
36	532155097	Pointer Height Indicator
37	532123935	Plug Hole Blk 1.485/1.515 Dia.
38	817490512	Screw Thdrol 5/16-18 x 3/4
40	819112410	Washer 11/32 x 1-1/2 10 Ga.
41	532155098	Indicator Height STLT
49	532145212	Nut Hex Flange Lock
50	532110452	Nut Phos & Oil

NOTE: All component dimensions given in U.S. inches
1 inch = 25.4 mm

REPAIR PARTS

TRACTOR - MODEL NO. YTH150 (HCLTH150E), PRODUCT NO. 954 14 00-07
HYDRO GEAR TRANSAXLE - MODEL NUMBER 310-0650

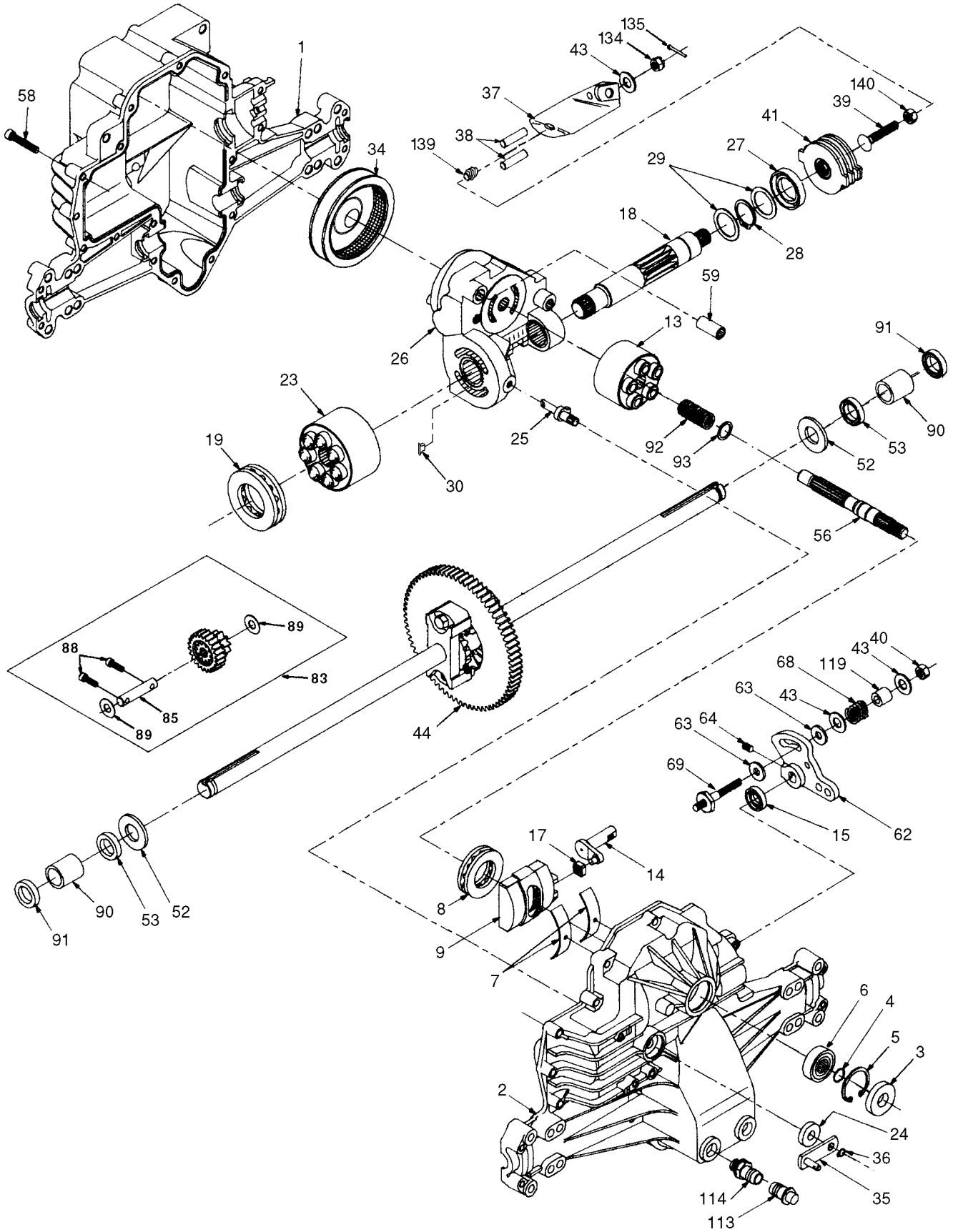

REPAIR PARTS

TRACTOR - MODEL NO. YTH150 (HCLTH150E), PRODUCT NO. 954 14 00-07

HYDRO GEAR TRANSAXLE - MODEL NUMBER 310-0650

KEY PART NO. NO.	DESCRIPTION	KEY PART NO. NO.	DESCRIPTION
1 532142930	Housing, Lower	43 532142884	Washer 7/16 x 7/8 x .060
2 532142931	Assembly, Upper Housing	44 532150829	Differential Assembly
3 532142932	Seal, Lip	52 532142991	Washer 3/4 x 1.5 x .13
4 532142928	Ring, Wire Retaining	53 532142961	Seal .75 x 1.25 x .250
5 532142933	Ring, Retaining	56 532142963	Shaft, Input
6 532142934	Bearing, Shaft Ball	58 532142964	Bolt 1/4-20 x 1.38
7 532142935	Bearing, Cradle	59 532142965	Pin .5 OD x .43 ID x .750
8 532150771	Bearing, Thrust 30 x 52 x 13	62 532142966	Arm, Control
9 532142937	Swashplate, Variable	63 532142967	Puck, Dampener
13 532142938	Block, Cylinder Assembly	64 532142920	Set Screw
14 532142939	Arm, Trunnion	68 532142969	Spring
15 532142940	Seal, Lip	69 532144610	Stud 5/16-24
17 532142941	Guide, Slot	83 532142971	Jackshaft Assembly
18 532150772	Shaft, Motor	85 532150806	Jackshaft
19 532150773	Bearing, Thrust 42 x 68 x 16	88 532142973	Screw, Cap
23 532142944	Block, Cylinder Assembly	89 532142974	Washer 7/16 x 1 x 1/2
24 532142945	Seal, Lip 10 x 25 x 7	90 532142975	Sleeve Bearing
25 532142946	Actuator, Bypass	91 532142976	Seal, Wiper
26 532150774	Center Section Assembly Kit	92 532142977	Spring, Block
27 532142948	Seal, Lip 26 x 42 x 8	93 532142978	Washer, Block Thrust
28 532142949	Ring, Retaining	113 532142917	Cap, Vent Assembly
29 532142950	Washer 26 x 35 x 1	114 532142918	Fitting, O-Ring Assembly
30 532150787	Plate, Bypass	119 532142980	Spacer
34 532142951	Oil Filter Element	134 532144607	Nut, Castle 5/16-24
35 532142952	Arm, Bypass	135 532144608	Pin, Cotter
36 532142953	Ring, Retaining	139 532150775	Spring, Compression
37 532142954	Arm, Actuating	140 532150776	Nut, Hex 5/16-24
38 532142955	Pin, Actuating		
39 532150777	Bolt 5/16-24 x 1-3/4		
40 532150778	Locknut, Hex 5/16-24 UNJC		
41 532142958	Brake Rotor/Stator Kit		

NOTE: All component dimensions given in U.S. inches
1 inch = 25.4 mm