

# YTH 1542 A

954567048

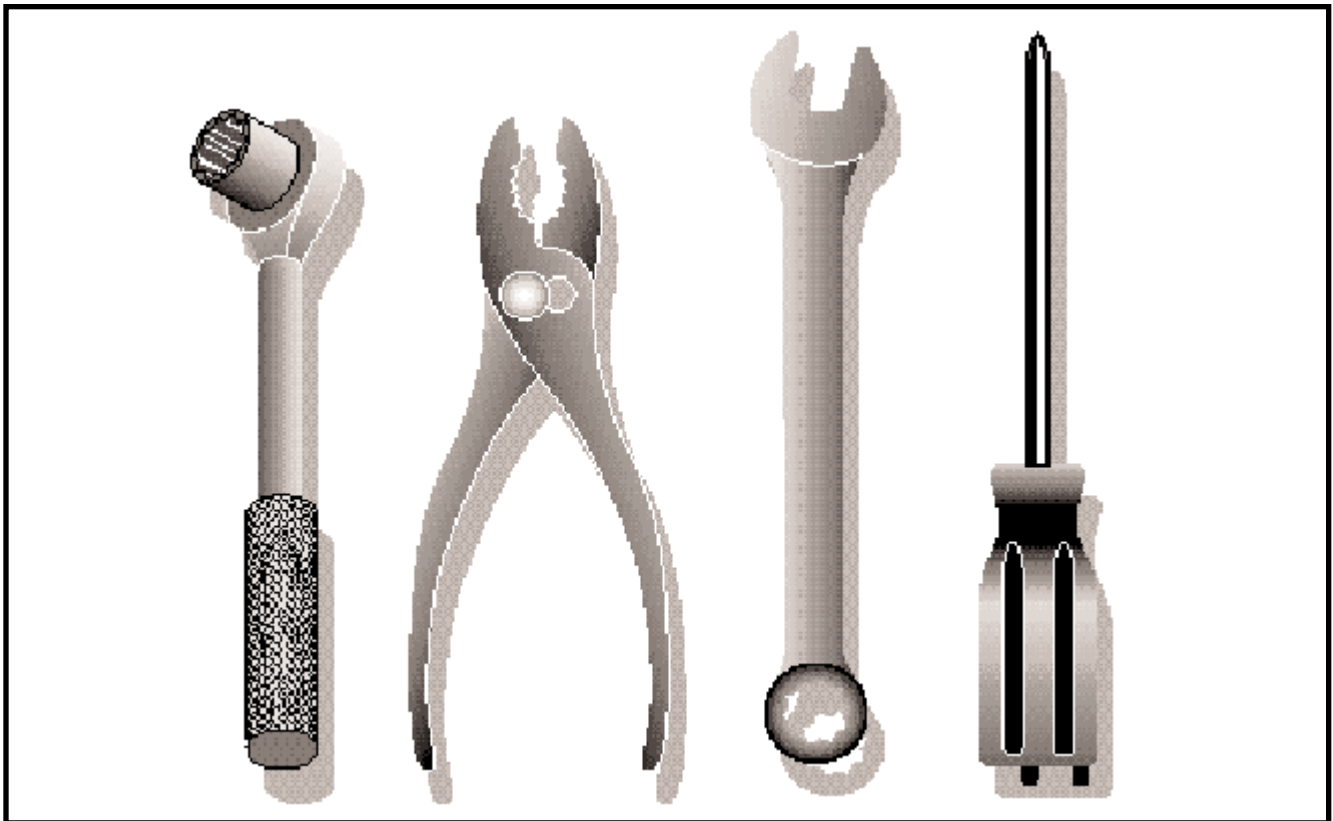

Repair Parts Manual

Ride Mower

# TRACTOR - MODEL NO. YTH1542 (YTH1542A), PRODUCT NO. 954 56 70-48 SCHEMATIC

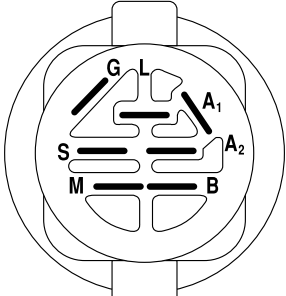
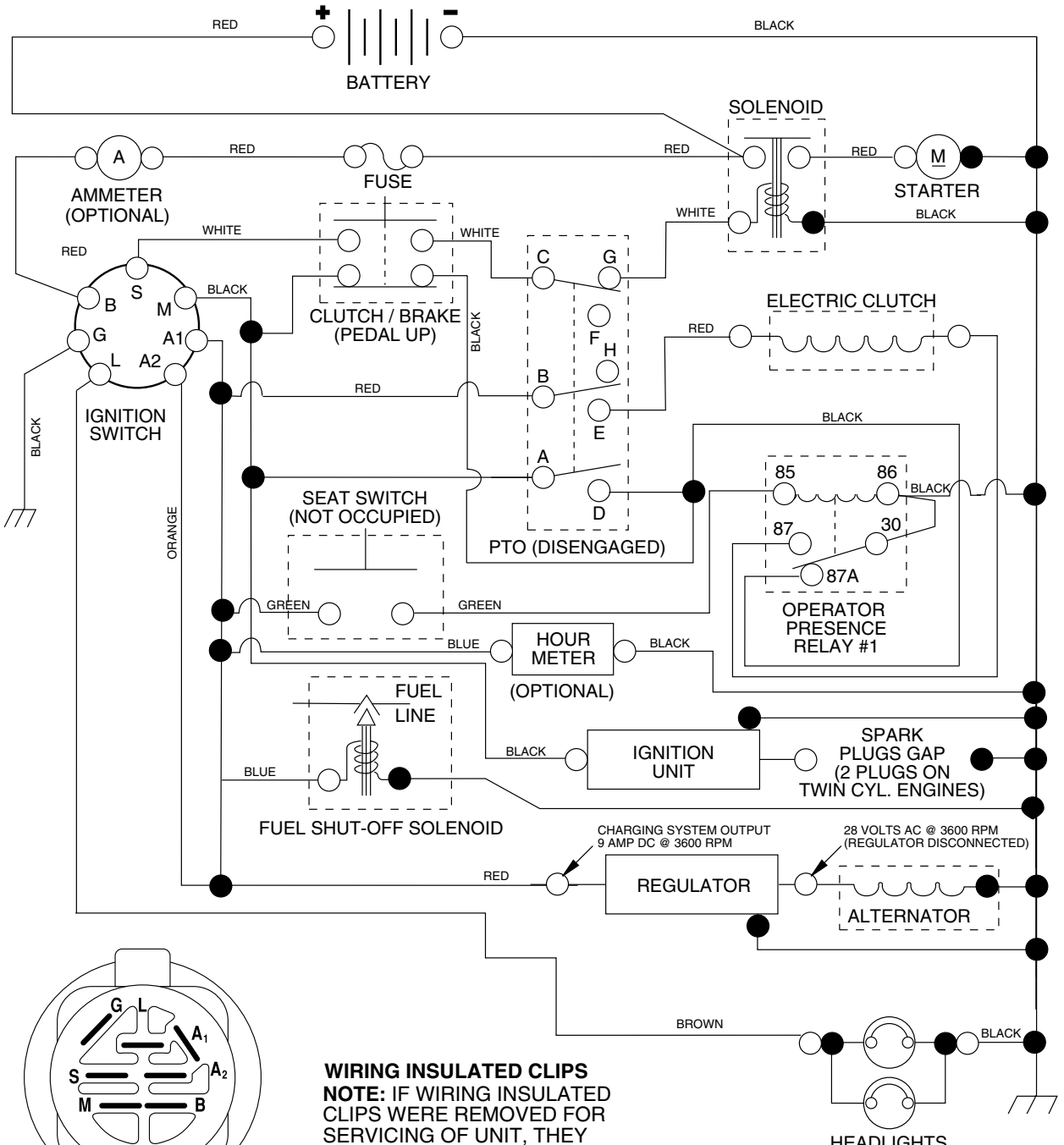



**IGNITION SWITCH**

POSITION	CIRCUIT	"MAKE"
OFF	M+G+A1	NONE
RUN/LIGHT	B+A1	A2+L
RUN	B+A1	NONE
START	B + S + A1	NONE

**WIRING INSULATED CLIPS**  
NOTE: IF WIRING INSULATED CLIPS WERE REMOVED FOR SERVICING OF UNIT, THEY SHOULD BE REPLACED TO PROPERLY SECURE YOUR WIRING.

**PTO SWITCH**

POSITION	CIRCUIT
OFF	C + G, B + H
ON	C + F, B + E, A + D

 NON-REMOVABLE CONNECTIONS  
 REMOVABLE CONNECTIONS

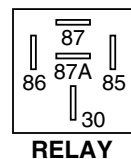

**RELAY**

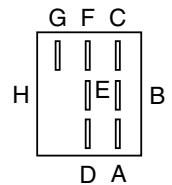

# REPAIR PARTS

TRACTOR - MODEL NO. YTH1542 (YTH1542A), PRODUCT NO. 954 56 70-48  
ELECTRICAL

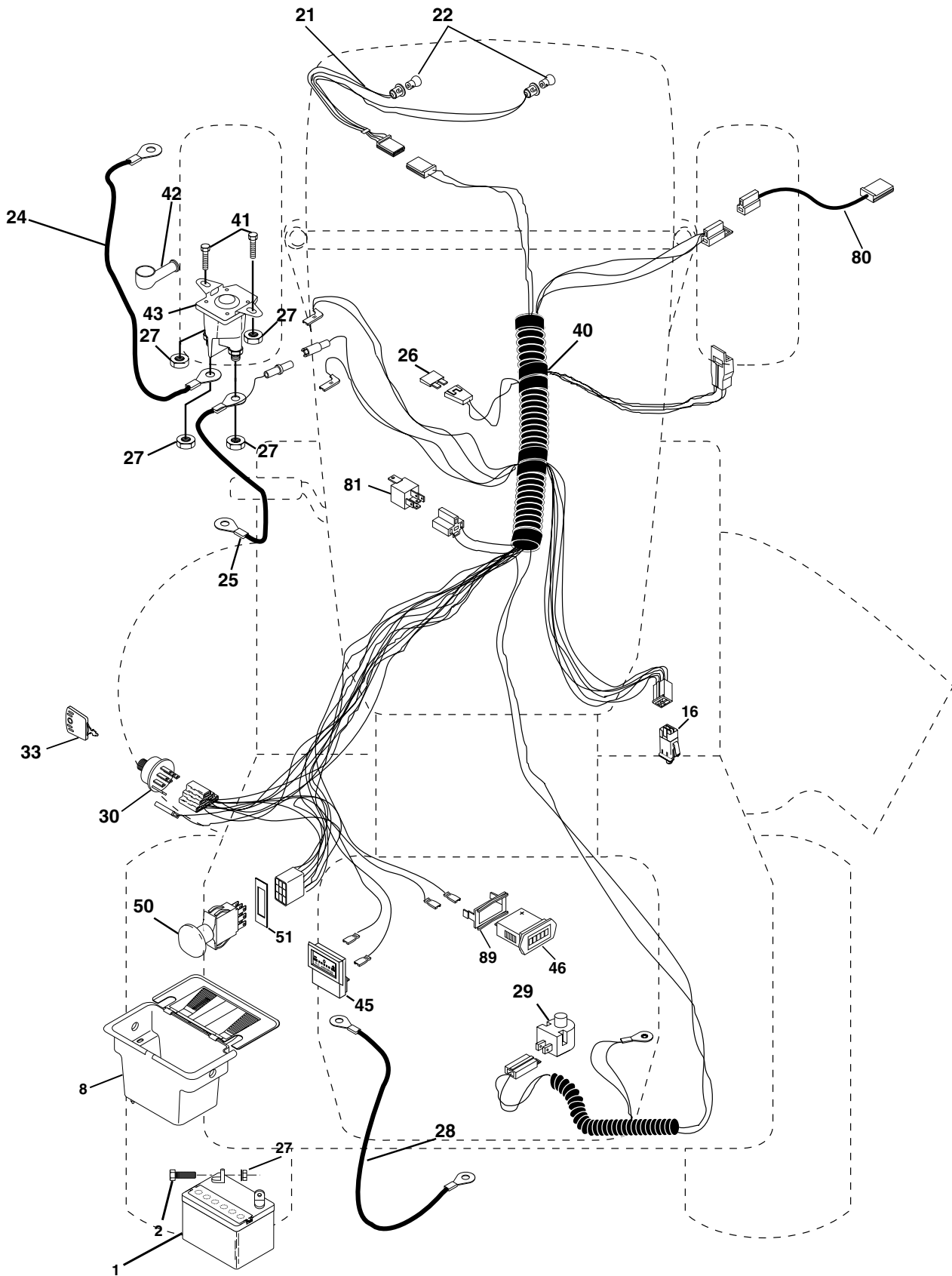

# REPAIR PARTS

TRACTOR - MODEL NO. YTH1542 (YTH1542A), PRODUCT NO. 954 56 70-48  
ELECTRICAL

KEY NO.	PART NO.	DESCRIPTION
1	532144925	Battery 12 Volt 25 AMP
2	874760412	Bolt Hex Hd 1/4-20unc X 3/4
8	532156417	Case Battery Mech Hinge
16	532153664	Switch Interlock Push-In
21	532166181	Harness Asm Light W/4152j
22	532004152	Bulb Light #1156
24	532124780	Cable Battery 6 Ga 11" red
25	532146147	Cable Battery 6 Ga 44" red w/16 wire
26	532175158	Fuse
27	873510400	Nut Keps Hex 1/4-20 Unc
28	532124773	Cable Ground 6 Ga 12" black
29	532160784	Switch Plunger Nc Gray
30	532175566	Switch Ign
33	532140401	Key Ign Generic
40	532170221	Harness Ign.
41	871110408	Bolt Blk Fin Hex 1/4 - 20 x 1/2
42	532131563	Cover Terminal Red
43	532175141	Solenoid
45	532122822	Ammeter Rectangular 15 Amp
46	532169635	Meter Hour
50	532174651	Switch PTO
51	532140405	Ring Retainer PTO
80	532146685	Harness Clutch Evx
81	532109748	Relay Asm.
89	532169639	Bracket Snap-In Hourmeter

**NOTE:** All component dimensions given in U.S. inches.  
1 inch = 25.4 mm.

# REPAIR PARTS

TRACTOR - MODEL NO. YTH1542 (YTH1542A), PRODUCT NO. 954 56 70-48  
CHASSIS AND ENCLOSURES

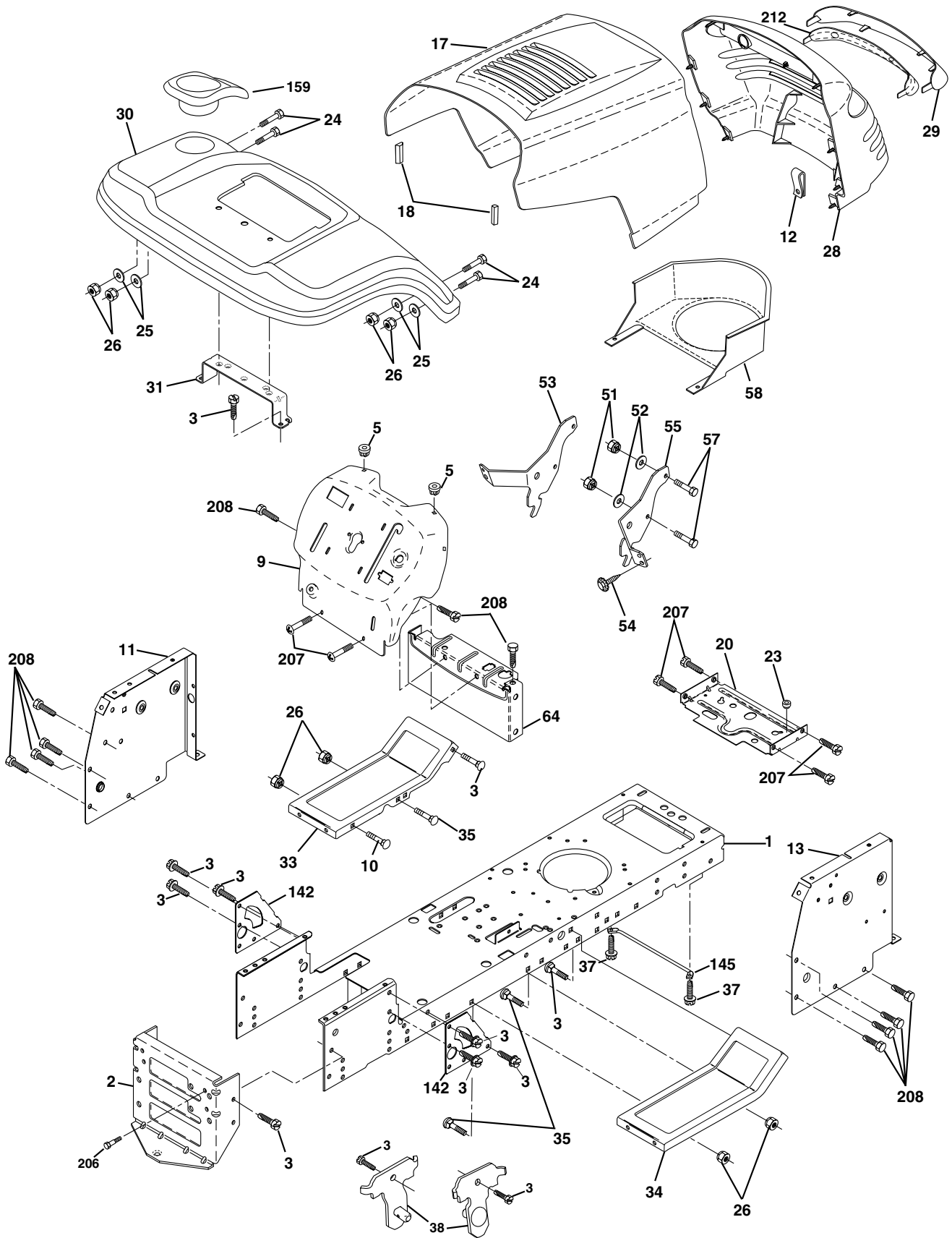

# REPAIR PARTS

## TRACTOR - MODEL NO. YTH1542 (YTH1542A), PRODUCT NO. 954 56 70-48 CHASSIS AND ENCLOSURES

KEY NO.	PART NO.	DESCRIPTION
1	532169830	Chassis stamping
2	532169061	Drawbar, 12 Ga.
3	817060612	Screw 3/8-16x3/4
5	532155272	Bumper Hood/Dash
9	532171682	Dash Slkscr
10	872140608	Bolt Carriage 3/8-16 x 1
11	532155927	Panel Dash Lh
12	532145660	Clip Tinnerman
13	532172106	Panel Dash Rh
17	532162237	Hood LT/PL
18	532126938	Bumper Hood
20	532156437	Plate Mtg Battery Fuel Tank Fr
23	532124028	Bushing
24	874780616	Bolt Fin Hex 3/8-16 Unc x 1 Gr. 5
25	819131312	Washer 13/32 X 13/16 X 12 Ga
26	873800600	Nut Lock Hex w/Ins. 3/8-16 Unc
28	532170475	Grille/Lens Asm
29	532176645	Lens
30	532169470	Fender
31	532136619	Bracket Fender
33	532147203	Footrest Pnt Lh
34	532147202	Footrest Pnt Rh
35	872110606	Bolt Rdhd Sht Sqnk 3/8-16 x 3/4
37	817490508	Screw Thdrol 6/16-18 x 1/2 TYT
38	532169834	Bracket Asm Pivot Mower Rear
51	873800400	Nut Lock w/Insert 1/4-20 Unc
52	819091416	Washer 9/32 x 7/8 x 16 Ga.
53	532144697	Bracket Grille Lh
54	532161464	Screw Hex Wsh 8-18 x 7/8
55	532144696	Bracket Grille Rh
57	874780412	Bolt Hex 1/4-20 x 3/4
58	532150127	Air Duct Engine P/L
64	532154798	Dash Lower STLT
142	532165867	Plate Reinforcement STLT
145	532156524	Rod Pivot Chassis/Hood
159	532177088	Cupholder Stlt Grey
206	532170165	Bolt Shoulder 5/16-18 TT
207	817670508	Screw Thdrol 5/16-18 x 1/2
208	817670608	Screw Thdrol 3/8-16 x 1/2
212	532156229	Insert Lens Reflective

**NOTE:** All component dimensions given in U.S. inches  
1 inch = 25.4 mm

# REPAIR PARTS

TRACTOR - MODEL NO. YTH1542 (YTH1542A), PRODUCT NO. 954 56 70-48  
DRIVE

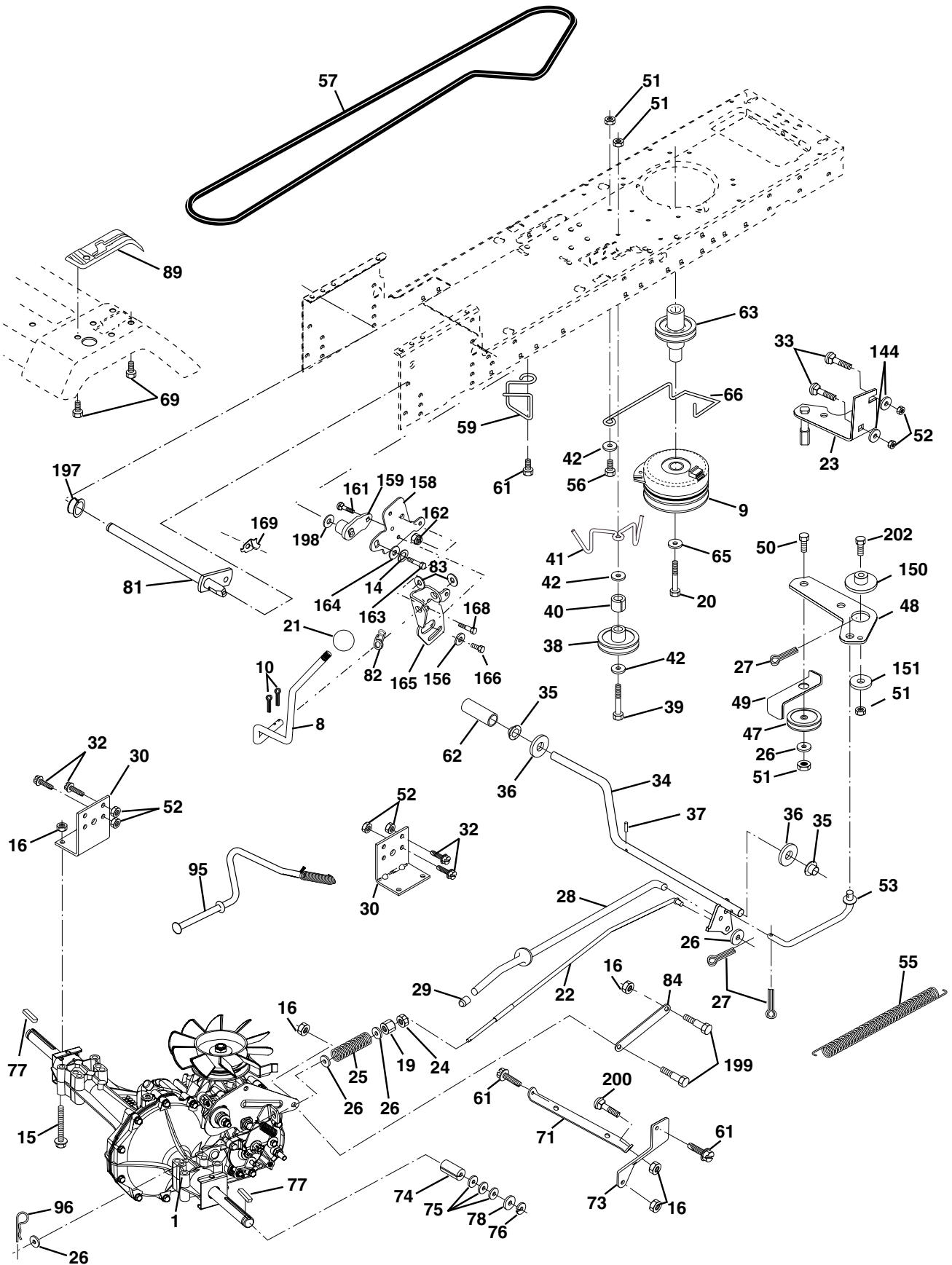

# REPAIR PARTS

## TRACTOR - MODEL NO. YTH1542 (YTH1542A), PRODUCT NO. 954 56 70-48 DRIVE

KEY PART NO. NO.	DESCRIPTION	KEY PART NO. NO.	DESCRIPTION
1	----- Transaxle Hydro Gr. 314-0510 (Order parts from transaxle mfg.)	61	817060612 Screw 3/8-16 x 3/4
8	532165619 Rod Shift Fender Adjust LT	62	532124872 Cover, Pedal
9	532145028 Clutch Electric	63	532145868 Pulley, Engine
10	876020416 Pin Cotter 1/8 x 1 CAD	65	810040700 Washer Lock Hvy HLCL Spr 7/16
14	810040400 Washer Lock Hvy Helical	66	532154778 Keeper Belt Engine
15	874490544 Bolt Hex 5/16-18 Gr. 5	69	532142432 Screw Hex Wsh Hi-Lo 1/4-1/2 Unc
16	873800500 Nut Lock Hex W/Ins. 5/16-18 Unc P	71	532169183 Strap Torque Lh
19	873800600 Nut Lock Hex W/Ins 3/8-16 Unc	73	532169182 Strap Torque Rh
20	532150280 Bolt, Hex 7/16-20 x 4-1/4 Ga. 5	74	532137057 Spacer, Axle
21	532140845 Knob Deluxe 1/2-13 UNC BLK/BLK	75	532121749 Washer 25/32 x 1-1/4 x 16 Ga.
22	532169498 Rod, Brake Hydro	76	812000001 E-Ring
23	532171258 Bracket Asm. Anti-Rot EVX	77	532123583 Key, Square
24	873350600 Nut Hex Jam 3/8-16 UNC	78	532121748 Washer 25/32 x 1-5/8 x 16 Ga
25	532106888 Spring, Brake Rod	81	532165596 Shaft Asm Cross Tapered
26	819131316 Washer	82	532123782 Spring Torsion
27	876020412 Pin Cotter 1/8 x 3/4 CAD.	83	819171216 Washer 17/32 x 3/4 x 16 Ga.
28	532145204 Rod, Parking Brake	84	532169594 Link Transaxle
29	532071673 Cap, Parking Brake	89	532176940 Console, Hydro
30	532169592 Bracket, Transaxle	95	532170201 Control Asm. Bypass Hydro
32	874760512 Bolt Hex Hd 5/16-18 Unc x 3/4	96	532124788 Retainer Spring 1" Zinc/Cad
33	872140506 Bolt Carriage 5/16-18 UNC x 3/4	144	819111016 Washer 11/32 x 5/8 x 16 Ga.
34	532155071 Shaft, Foot Pedal	150	532165850 Bushing Bellcrank Grd Drive
35	532120183 Bearing, Nylon	151	819133210 Washer 13/32 x 2 x 10 Ga.
36	819211616 Washer	156	532166002 Washer Srrted 5/16 ID X 1 X .125
37	532124963 Pin, Roll	158	532165589 Bracket Shift Mount
38	532131494 Pulley, Idler, Flat	159	532165494 Hub Tapered Flange Shift LT
39	874760644 Bolt	161	872140406 Bolt Rdhd Sqnk 1/4-20 x 3/4 Gr. 5
40	532124965 Spacer Split	162	873680400 Nut Crownlock 1/4-20 Unc
41	532165838 Keeper, Belt Idler	163	874780416 Bolt Hex Fin 1/4-20 Unc x 1 Gr. 5
42	819131312 Washer 13/32 x 13/16 x 12 Ga	164	819091010 Washer 5/8 x .281 x 10 Ga.
47	532127783 Pulley, Idler, V-Groove Plastic	165	532165623 Bracket Pivot Lever
48	532154407 Bellcrank Clutch Grnd Drv Stl	166	532166880 Screw 5/16-18 x 5/8
49	532123205 Retainer, Belt Style Spring	168	532165492 Bolt Shoulder 5/16-18 x .561
50	874760624 Bolt Hex Hd 3/8-16 Unc x 1-1/2	169	532165580 Plate Fastening LT
51	873680600 Nut	197	532169613 Nyliner Snap-In 5/8" ID
52	873680500 Nut Crown Lock 5/16-18	198	532169593 Washer Nyl 7/8ID x .105 Hyd
53	532105710 Link, Clutch	199	532169612 Bolt Shoulder 5/16-18 Unc
55	532105709 Spring, Return, Clutch	200	872140508 Bolt Rdhd Sqnk 5/16-18 Unc x 1
56	874760620 Bolt, Fin Hex 3/8-16 UNC x 1 1/4	202	872110612 Bolt
57	532140294 V-Belt, Ground Drive		
59	532169691 Keeper, Center Span		

**NOTE:** All component dimensions given in U.S. inches  
1 inch = 25.4 mm



# REPAIR PARTS

TRACTOR - MODEL NO. YTH1542 (YTH1542A), PRODUCT NO. 954 56 70-48  
STEERING ASSEMBLY

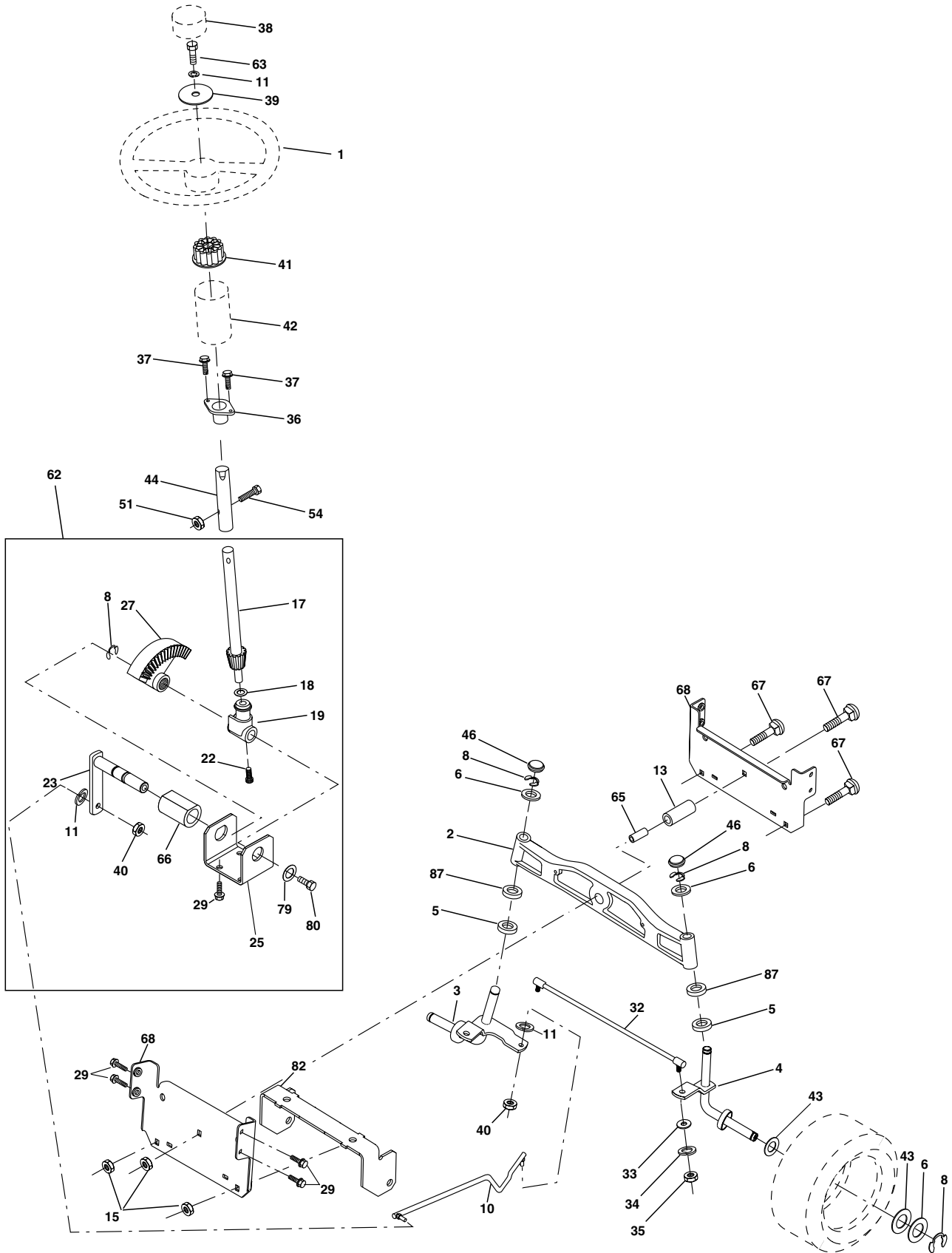

# REPAIR PARTS

## TRACTOR - MODEL NO. YTH1542 (YTH1542A), PRODUCT NO. 954 56 70-48 STEERING ASSEMBLY

KEY NO.	PART NO.	DESCRIPTION
1	532166627	Wheel Steering
2	532172393	Axle Cast LT Machined
3	532169840	Spindle Asm Cast LH
4	532169839	Spindle Asm Cast RH
5	532124931	Bearing Race Thrust Harden
6	532121748	Washer 25/32 X 1-5/8 X 16 Ga
8	812000029	Ring Klip #t5304-75
10	532169832	Link Drag
11	810040600	Washer Lock Hvy Hlcl Spr 3/8
13	532136518	Spacer Brg Axle Front
15	532145212	Nut Hex Flange Lock Yel D
17	532156546	Shaft Asm Strg Private Label
18	532057079	Washer Thrust 515x 750x 033
19	532160395	Support Shaft
22	532165857	Screw Hex Wshhd Torx
23	532165851	Shaft Asm Pittman
25	532154406	Bracket Steering
27	532136874	Gear Sector 22 Teeth
29	817060612	Screw 3/8-16x3/4
32	532171888	Rod Tie
33	819111216	Washer 11/32 x 3/4 x 16 Ga.
34	810040500	Washer Lock Hvy. Helical 5/16 SD
35	873540600	Nut Crown Lock 5/16-24
36	532155099	Bushing Strg
37	532152927	Screw TT #32.5 x 5 x 3/8 Flange
38	532166626	Cap Wheel Steer
39	819132411	Washer 13/32 x 1-1/20 x 11 Ga.
40	532124701	Nut Lock Center 3/8-24 Unf
41	532159945	Adaptor Wheel Strg
42	532169634	Boot Dash Steering
43	532121749	Washer 25/32 X 1 1/4 X 16 Ga
44	532153720	Extension Steering Non-adjust
46	532121232	Cap Spindle Fr Top Blk
51	873800500	Nut Lock Hex W/Ins 5/16-18 UNC
54	874780520	Bolt Fin Hex 5/16-18 UNC x 1-1/4
62	532167902	Steering Assembly
63	874780616	Bolt Fin Hex 3/8-16 UNC x 1 Gr. 5
65	532160367	Spacer, Brace Axle
66	532154404	Bearing Arm Pittman
67	872140618	Bolt Rdhd 3/8-16 x 2-1/4
68	532169827	Brace, Axle
79	819132012	Washer 13/32 x 1-1/4 x 12 Ga.
80	874950612	Bolt Hex Nylon 3/8-16 x 3/4
82	532169835	Bracket Susp Chassis Front 15"
87	532173966	Washer Flat .781 x 1-1/2 x .14

**NOTE:** All component dimensions given in U.S. inches.  
1 inch = 25.4 mm.

# REPAIR PARTS

## TRACTOR - MODEL NO. YTH1542 (YTH1542A), PRODUCT NO. 954 56 70-48 SEAT ASSEMBLY

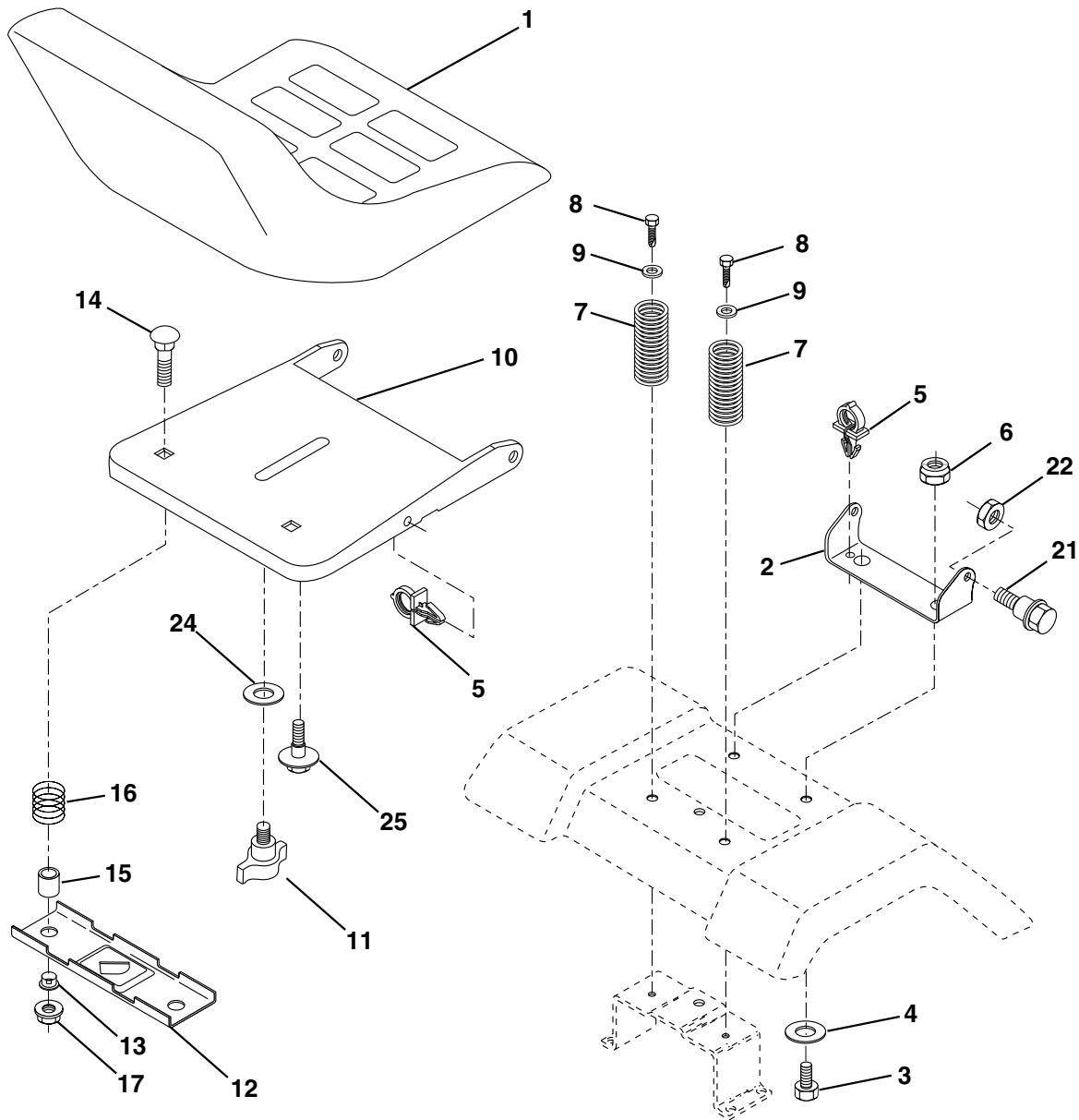

KEY PART NO.	NO.	DESCRIPTION
1	532140839	Seat
2	532140551	Bracket Pivot Seat 8 720
3	871110616	Bolt Fin Hex 3/8-16unc X 1
4	819131610	Washer 13/32 X 1 X 10 Ga
5	532145006	Clip Push-In
6	873800600	Nut Hex w/Ins. 3/8-16 Unc
7	532124181	Spring Seat Cprsn 2 250 Blk Zi
8	817000616	Screw 3/8-16 X 1
9	819131614	Washer 13/32 X 1 X 14 Ga.
10	532174894	Pan Seat
11	532166369	Knob Seat Adj Wingnut
12	532121246	Bracket Mounting Switch

KEY PART NO.	NO.	DESCRIPTION
13	532121248	Bushing Snap Blk Nyl 50 Id
14	872050412	Bolt Rdhd Sqnk 1/4-20x1-1/2
15	532134300	Spacer Split 28x 96 Yel Zinc
16	532121250	Spring Cprsn 1 27 Blk Prnt
17	532123976	Nut Lock 1/4 Lge Flg Gr 5 Zinc
21	532171852	Bolt Shoulder 5/16-18 Unc
22	873800500	Nut Hex Lock W/Ins 5/16-18
24	819171912	Washer 17/32 X 1-3/16 X 12 Ga.
25	532127018	Bolt Shoulder 5/16-18 X 62

**NOTE:** All component dimensions given in U.S. inches.  
1 inch = 25.4 mm

# REPAIR PARTS

TRACTOR - MODEL NO. YTH1542 (YTH1542A), PRODUCT NO. 954 56 70-48  
DECALS

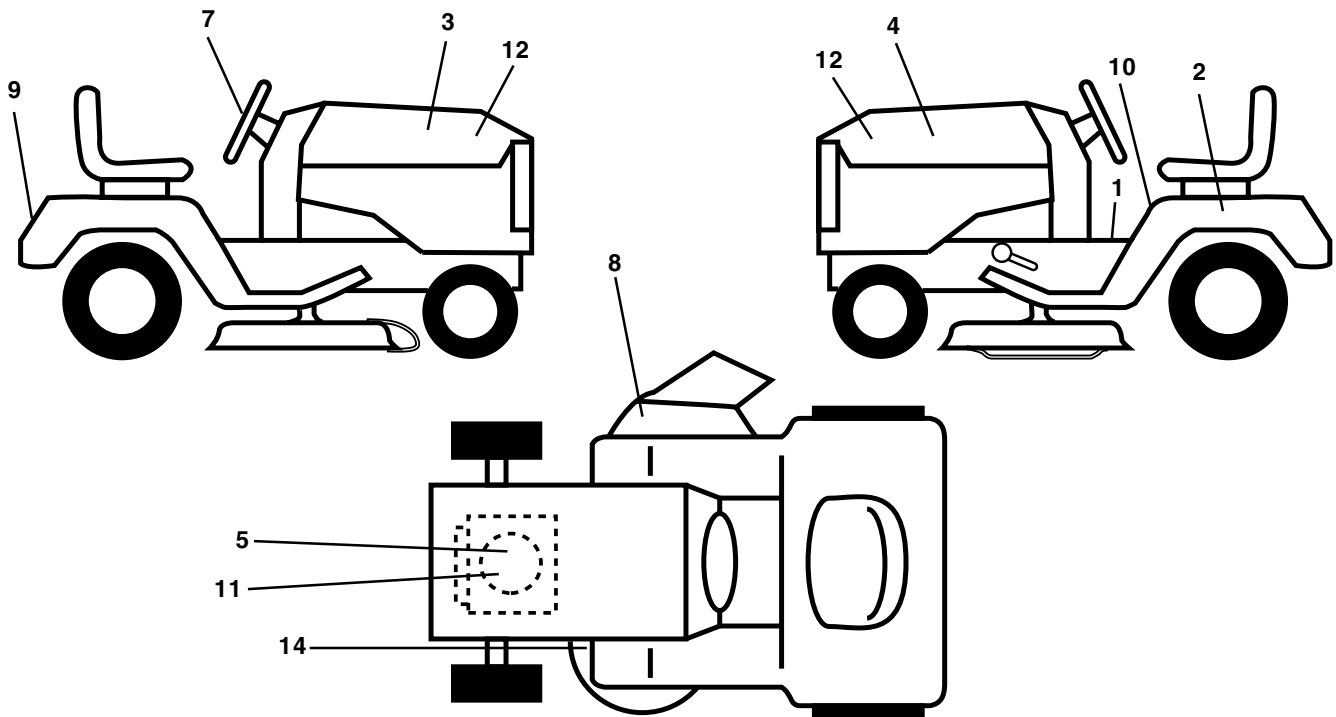

KEY NO.	PART NO.	DESCRIPTION	KEY NO.	PART NO.	DESCRIPTION
1	532157032	Decal Oper. Step Thru E/F	10	532157140	Decal Fender Danger E/F
2	532145005	Decal Battery	11	532176775	Decal Engine
3	532176784	Decal Hood RH	12	532176776	Decal Hood Logo
4	532176785	Decal Hood LH	14	532160396	Decal V-Belt Schematic
5	532176779	Decal HP Engine	--	532133671	Pad Footrest
7	532170564	Decal Wheel Steering	--	532138311	Decal Handle Lft Height Adjust
8	532170563	Decal Warning	--	532169210	Decal By Pass Lt Hydro
9	532176822	Decal Fender Husq	--	532176786	Manual Owner's (English)
			--	532176787	Manual Owner's (French)

## WHEELS & TIRES

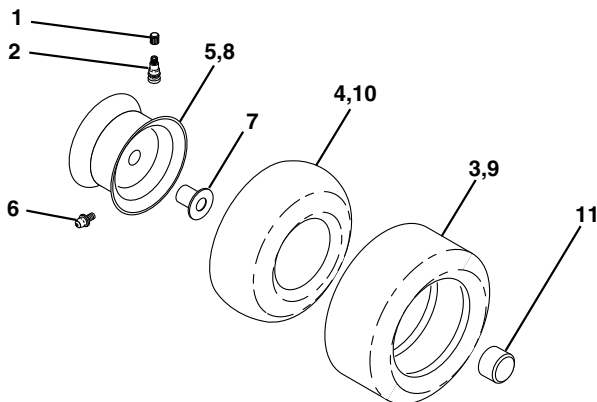

KEY NO.	PART NO.	DESCRIPTION
1	532059192	Cap Valve Tire
2	532065139	Stem Valve
3	532106222	Tire F Ts 15 X 6 0 - 6 Service
4	532059904	Tube Front (Service Item Only)
5	532138336	Rim Asm 6"front Silver Service
6	532124957	Fitting Grease (Front Wheel Only)
7	532124959	Bearing Flange (Front Wheel Only)
8	532138337	Rim Asm 8"rear Silver Service
9	532122082	Tire R Ts 20x10-8 C Service
10	532124926	Tube Rear (Service Item Only)
11	532175039	Cap Axle Blk 1 50 X 1 00
--	532144334	Sealant, Tire ( 10 oz. Tube)

**NOTE:** All component dimensions given in U.S. inches  
1 inch = 25.4 mm

# REPAIR PARTS

TRACTOR - MODEL NO. YTH1542 (YTH1542A), PRODUCT NO. 954 56 70-48  
ENGINE

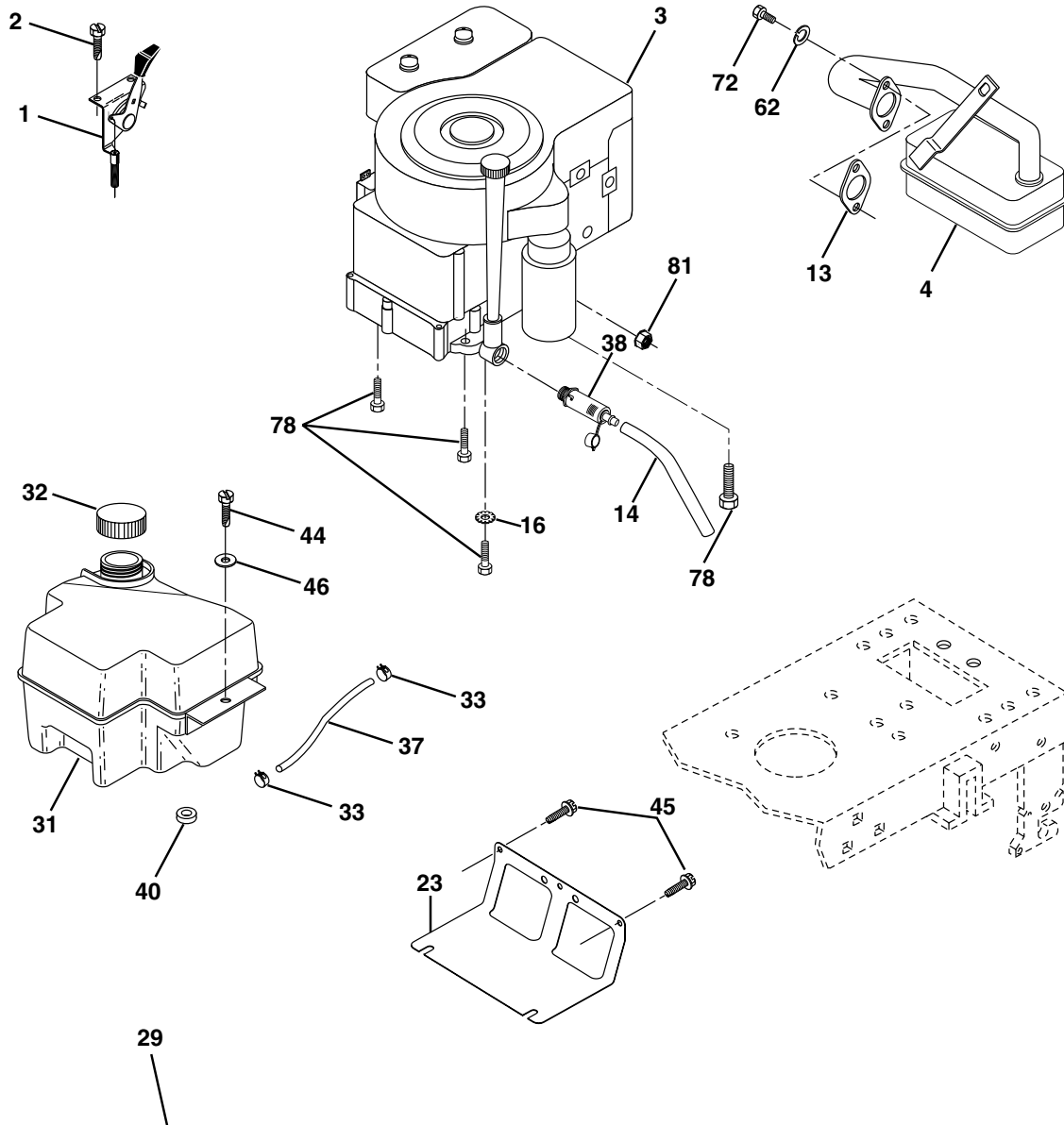

**OPTIONAL EQUIPMENT**  
**Spark Arrester**

KEY NO.	PART NO.	DESCRIPTION
1	532170551	Control Th/ch Flag Dom.
2	817720410	Screw Hex Thd Ext Cut 1/4-20x5/8 T
3	-----	Engine B&S Model 311777 (Order parts from engine manufacturer)
4	532137352	Muffler
13	532165291	Gasket
14	532148456	Tube Drain Oil Easy
16	811050600	Washer Lock Ext Tooth 3/8
23	532169837	Shield BRN/DBR Guard
29	532137180	Kit Spark Arrestor (Flat Scrm)
31	532174642	Tank Fuel
32	532140527	Cap Asm Fuel W/sym Vented

KEY NO.	PART NO.	DESCRIPTION
33	532123487	Clamp Hose Black
37	532137040	Line Fuel
38	532148315	Plug Drain Oil Easy
40	532124028	Bushing Snap Nyl Black Fuel Line
44	817670412	Screw Hex Wsh Thdrol 1/4-20 x 3/4
45	817000612	Screw Hex Wsh Thdrol 3/8-16 x 3/4
46	819091416	Washer 9/32 x 7/8 x 16 Ga.
62	810040500	Washer Lock Hvy Hlcl Spr. 5/16
72	871070512	Screw Hex Hd Cap 5/16-18 x 3/4
78	817060620	Screw 3/8-16 x 1-1/4
81	873510400	Nut Keps Hex 1/4-20 Unc

**NOTE:** All component dimensions given in U.S. inches  
1 inch = 25.4 mm

# REPAIR PARTS

## TRACTOR - MODEL NO. YTH1542 (YTH1542A), PRODUCT NO. 954 56 70-48 MOWER LIFT

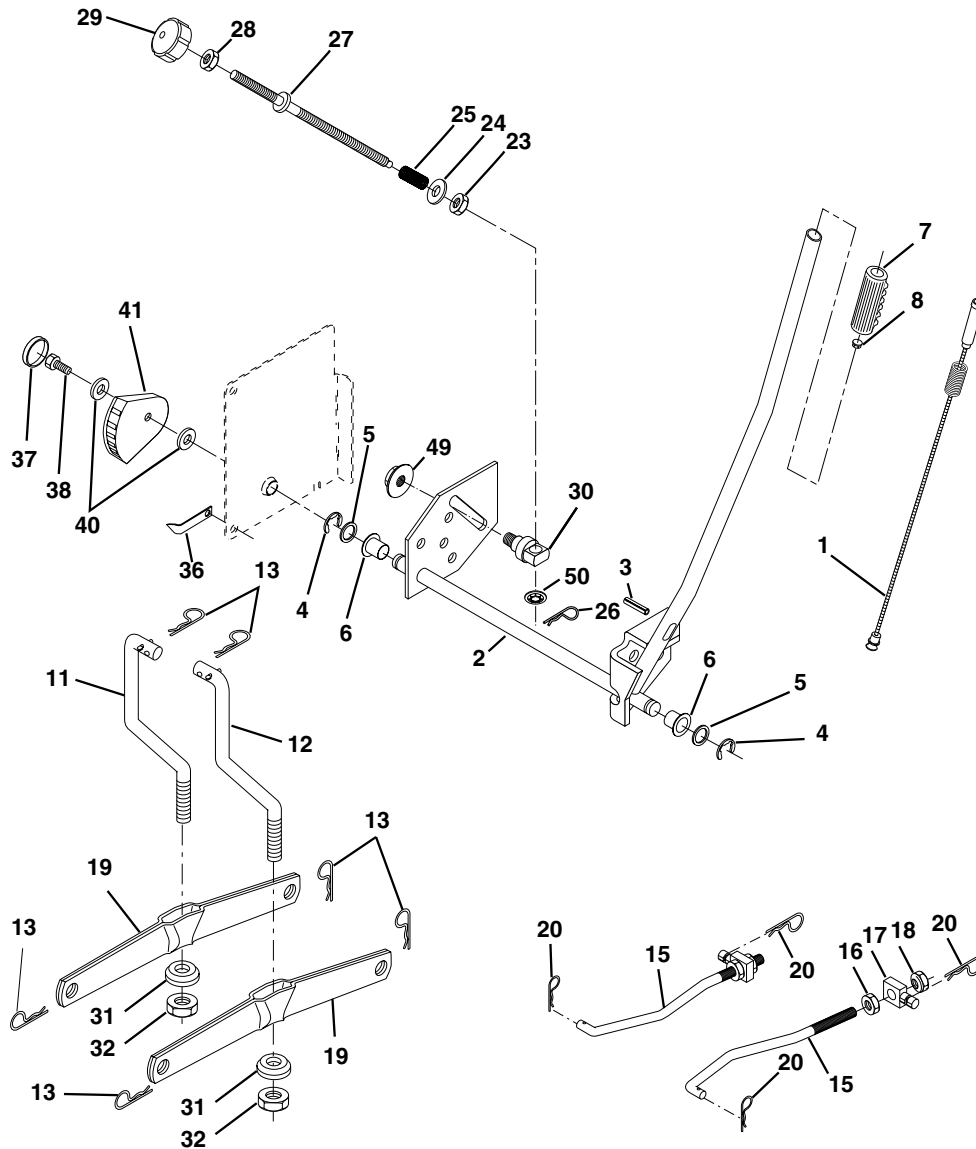

KEY NO.	PART NO.	DESCRIPTION
1	532159460	Wire Asm Inner W/plunger
2	532159471	Shaft Asm Lift RH w/Inf
3	532105767	Pin Groove 1 500 Zinc
4	812000002	E Ring #5133-62
5	819211621	Washer 21/32 X 1 X 21 Ga
6	532120183	Bearing Nylon Blk 629 Id
7	532125631	Grip Handle Fluted Blk
8	532124526	Button Plunger Black
11	532139865	Link Lift LH Fixed Length
12	532139866	Link Lift RH Fixed Length
13	532124670	Retainer Spring
15	532173288	Link Front
16	873350800	Nut Jam Hex 1/2-13 Unc
17	532130171	Trunnion Blk Zinc
18	873800800	Nut Lock w/Wsh 1/2-13unc
19	532139868	Arm Suspension Rear
20	532163552	Retainer Spring
23	532110807	Nut Special

KEY NO.	PART NO.	DESCRIPTION
24	819131016	Washer 13/32 X 5/8 X 16 Ga
25	532124874	Spring 2-1/8"
26	532169484	Retainer Clip
27	532126971	Rod Adj Lift Zinc 7.49 Wrk Lg
28	873350600	Nut Hex Jam 3/8-16 Unc
29	532138057	Knob Inf 3/8-16 Unc Blk W/sym
30	532150233	Trunnion Infin Height
31	532169865	Bearing Pvt Lift
32	873540600	Nut Crownlock 3/8 - 24
36	532155097	Pointer Height Indicator
37	532123935	Plug Hole Blk 1.485/1.515 Dia.
38	817060516	Screw 5/16-18 x 1
40	819112410	Washer 11/32 x 1-1/2 10 Ga.
41	532155098	Indicator Height STLTL
49	532145212	Nut Hex Flange Lock
50	532110452	Nut Phos & Oil

**NOTE:** All component dimensions given in U.S. inches  
1 inch = 25.4 mm

# REPAIR PARTS

TRACTOR - MODEL NO. YTH1542 (YTH1542A), PRODUCT NO. 954 56 70-48  
MOWER DECK

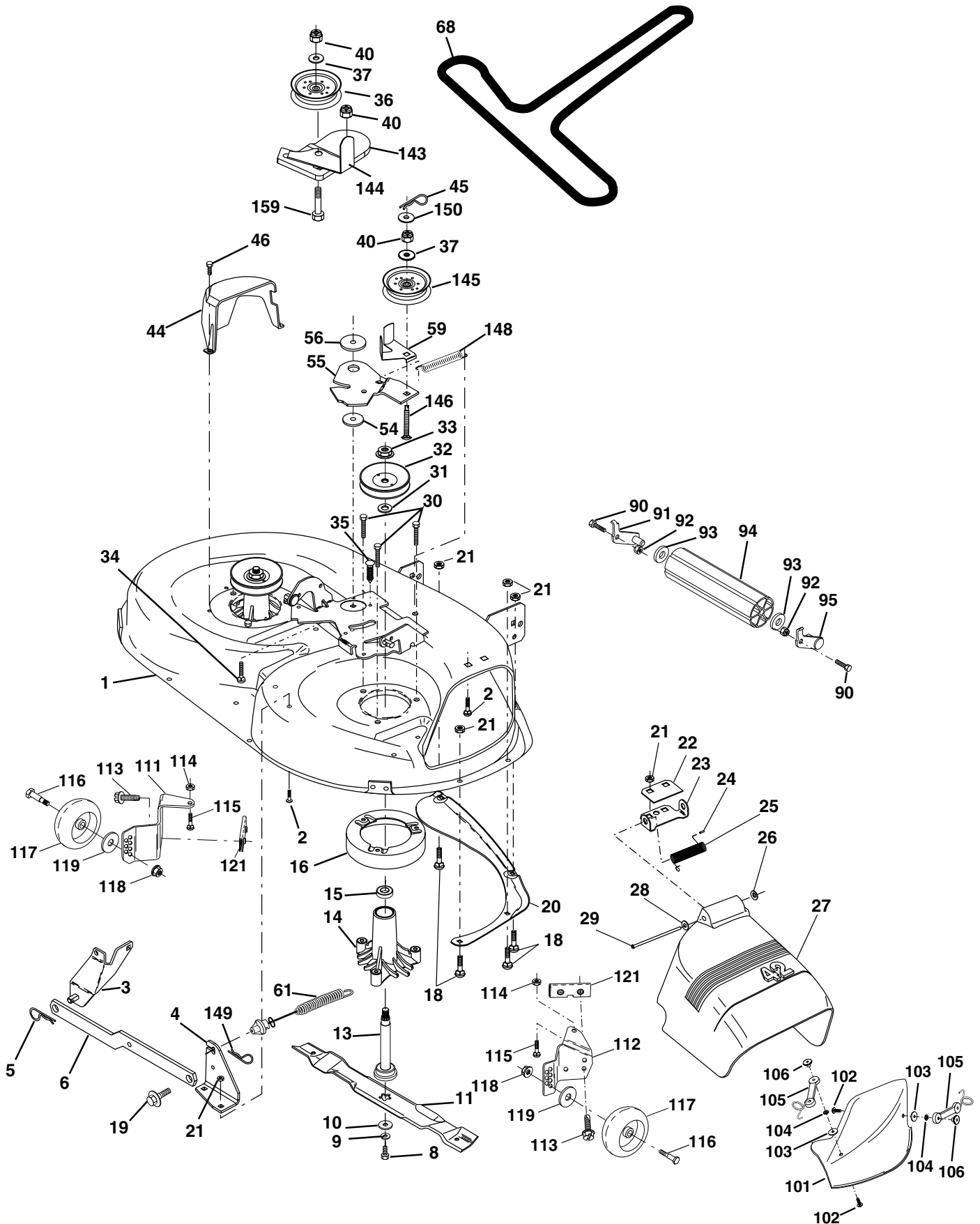

# REPAIR PARTS

## TRACTOR - MODEL NO. YTH1542 (YTH1542A), PRODUCT NO. 954 56 70-48 MOWER DECK

KEY NO.	PART NO.	DESCRIPTION	KEY NO.	PART NO.	DESCRIPTION
1	532176922	Mower Deck Assembly, 42"	61	532174882	Spring Ext Elect Clutch 42" Dck
2	872140506	Bolt	68	532174883	V-Belt
3	532138017	Bracket Assembly, Sway Bar, Front	90	874760616	Bolt Fin Hex 3/8-16 Unc x 1
4	532176935	Bracket Sway Bar 38/42" Deck	91	532132274	Bracket Asm Noseroller Lh
5	532124670	Retainer Spring	92	873800600	Nut Lock Hex w/Ins. 3/8-16 Unc
6	532130832	Arm, Suspension, Rear	93	819171416	Washer 17/32 x 7/8 x 16 Ga.
8	532850857	Bolt, Hex 3/8-24 x 1.25 Gr. 8	94	532132264	Roller Nose 38"-50"
9	810030600	Washer, Lock	95	532132273	Bracket Asm Noseroller Rh
10	532140296	Washer, Hardened	101	532136420	Mulcher Cover
11	532138498	Blade Mower 42" High Perf.	102	871081010	Screw
	532134149	Blade, Mulching	103	819061216	Washer #10
13	532137645	Shaft Assembly, Mandrel, Vented	104	810071000	Washer, Lock
14	532128774	Housing, Mandrel, Vented	105	532160793	Latch Assembly, Bagger
15	532110485	Bearing, Ball, Mandrel	106	532125004	Nut, Weld
16	532140329	Stripper, Vented Mower Deck	111	532176933	Bracket, Gauge, Wheel L.H.
18	872140505	Bolt, Carriage 5/16-18 x 5/8	112	532176934	Bracket, Gauge, Wheel R.H.
19	532132827	Bolt, Shoulder	113	817060514	Screw Tapping 5/16-18 Unc
20	532159770	Baffle, Vortex	114	873510500	Nut, Hex, Keps 5/16-18 UNC
21	873680500	Nut Crownlock 5/16-18 UNC	115	872110504	Bolt, Carriage 5/16 UNC x 1/2
22	532176929	Stiffener Bracket	116	532137644	Bolt, Shoulder
23	532176927	Bracket, Deflector	117	532165746	Wheel, Gauge
24	532105304	Cap, Sleeve	118	873930600	Nut, Centerlock 3/8-16
25	532123713	Spring, Torsion, Deflector	119	819121414	Washer 3/8 x 7/8 x 14 Gauge
26	532110452	Nut, Push	121	532173986	Bracket
27	532171634	Shield, Deflector	143	532176931	Bracket Arm Idler 42"
28	819111016	Washer 11/32 x 5/8 x 16 Ga.	144	532173441	Keeper Belt 42" Clutch Cable
29	532131491	Rod, Hinge	145	532173437	Pulley Idler Flat
30	532157722	Screw Thdrol Washer Head	146	532171977	Bolt Carriage Idler
31	532129963	Washer, Spacer	148	532169022	Spring Return Idler
32	532173436	Pulley, Mandrel	149	532165898	Retainer Spring Yellow Zinc
33	532137266	Nut, Toplock, Flanged	150	819091216	Washer 9/32 x 3/4 x 16 Ga.
34	872110614	Bolt	159	872140614	Bolt Rdhd Sqn 3/8-16 UNC x 1- 3/4
35	532133835	Fastner, Christmas Tree	--	532130794	Mandrel Assembly (Includes Key Numbers 8-10, 13-15, 31 and 32)
36	532173438	Pulley, Idler, Flat	--	532176789	Mower Deck, Complete (Standard Deck, Order Separately Noseroller, Mulcher Plate and Gauge Wheel Components, Key Nos. 90-95, 101-106 and 111-121)
37	819131316	Washer 13/32 x 13/16 x 16 Gauge			
40	873680600	Nut Crownlock 3/8-16 UNC			
44	532140088	Guard, Mandrel, L.H.			
45	532124788	Retainer			
46	532137729	Screw, Thd. Roll 1/4-20 x 5/8			
54	532133943	Washer, Hardened			
55	532176932	Arm, Idler			
56	532165723	Spacer, Retainer			
59	532173442	Guard, TUV Idler			

**NOTE:** All component dimensions given in U.S. inches  
1 inch = 25.4 mm