

CT150

Spare parts
Ersatzteile
Pièces détachées
Reserve onderdelen
Repuestos
Reservdelar

TRACTOR- -MODEL NO. CT150 (HECT150C) PRODUCT NO. 954 17 00-19 SCHEMATIC

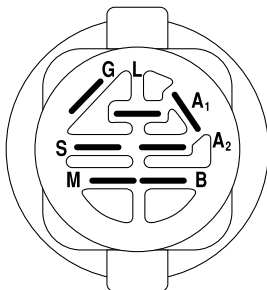
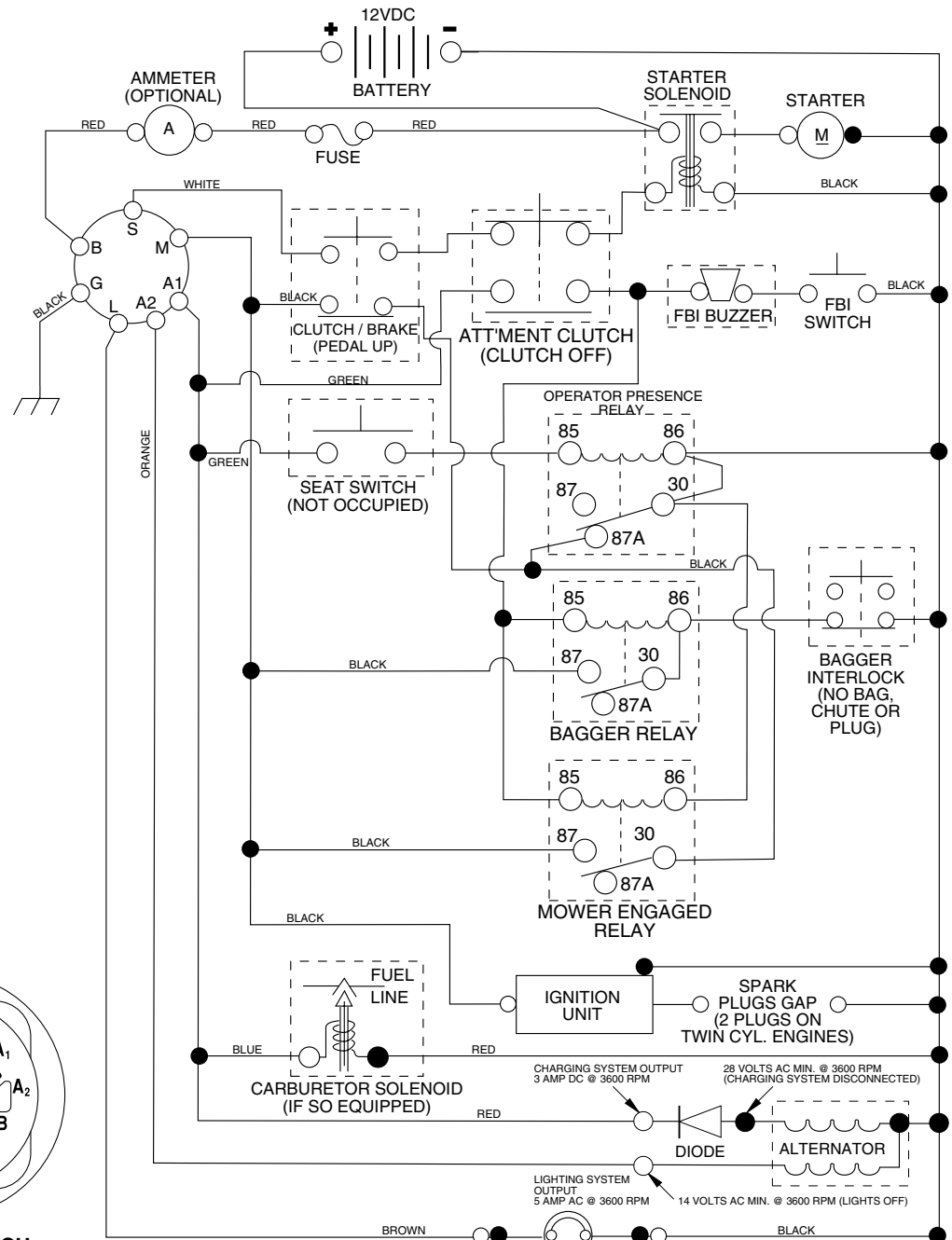

IGNITION SWITCH

POSITION	CIRCUIT	"MAKE"
OFF	M+G+A1	NONE
RUN/LIGHT	B+A1	A2+L
RUN	B+A1	NONE
START	B + S + A1	NONE

WIRING INSULATED CLIPS
NOTE: IF WIRING INSULATED CLIPS WERE REMOVED FOR SERVICING OF UNIT, THEY SHOULD BE REPLACED TO PROPERLY SECURE YOUR WIRING.



PTO SWITCH

POSITION	CIRCUIT
OFF	C + G, B + H
ON	C + F, B + E, A + D

HEADLIGHTS

NOTE
YOUR TRACTOR IS EQUIPPED WITH A SPECIAL ALTERNATOR SYSTEM. THE LIGHTS ARE NOT CONNECTED TO THE BATTERY, BUT HAVE THEIR OWN ELECTRICAL SOURCE. BECAUSE OF THIS, THE BRIGHTNESS OF THE LIGHTS WILL CHANGE WITH ENGINE SPEED. AT IDLE THE LIGHTS WILL DIM. AS THE ENGINE IS SPEEDED UP, THE LIGHTS WILL BECOME THEIR BRIGHTEST.

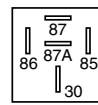

RELAY

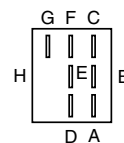

REPAIR PARTS

TRACTOR- -MODEL NO. CT150 (HECT150C) PRODUCT NO. 954 17 00-19
ELECTRICAL

KEY NO.	PART NO.	DESCRIPTION
1	532144925	Battery 12 Volt 25 AMP Wet
2	874760412	Bolt Hex Hd 1/4-20 Unc X 3/4
16	532153664	Switch Interlock Push-In
21	532166181	Harness Asm Light W/4152J
22	532004152	Bulb Light #1156
24	532124780	Cable Starter 6Ga 11" Red
25	532165987	Cable Battery Crd 56" Red
26	532166180	Fuse 15 Amp
27	873510400	Nut Keps Hex 1/4-20 Unc
28	532127725	Cable Ground 6Ga 18" Black
29	532160784	Switch Plunger Normal Op Olive
30	532175566	Switch Ignition
33	532140401	Key Ign Molded
40	532170164	Harness Ign Crd Noram
41	871110408	Bolt Flk Fin Hex 1/4-20 Unc X 1/2
42	532131563	Cover Terminal Red
43	532175141	Solenoid
48	532140844	Adapter Ammeter Rectangular
52	532141940	Protection Wire Loop
58	532169419	Buzzer Crd
59	532166299	Switch FBI CRD
65	817211008	Screw Slftp #10-16 x 1/2 Ty-Ab
66	817490608	Screw Thdrol 3/8-16 x 1/2 Ty-Tt
81	532109748	Relay Asm

NOTE: All component dimensions given in U.S. inches.
1 inch = 25.4 mm.

REPAIR PARTS

TRACTOR- -MODEL NO. CT150 (HECT150C) PRODUCT NO. 954 17 00-19
CHASSIS AND ENCLOSURES

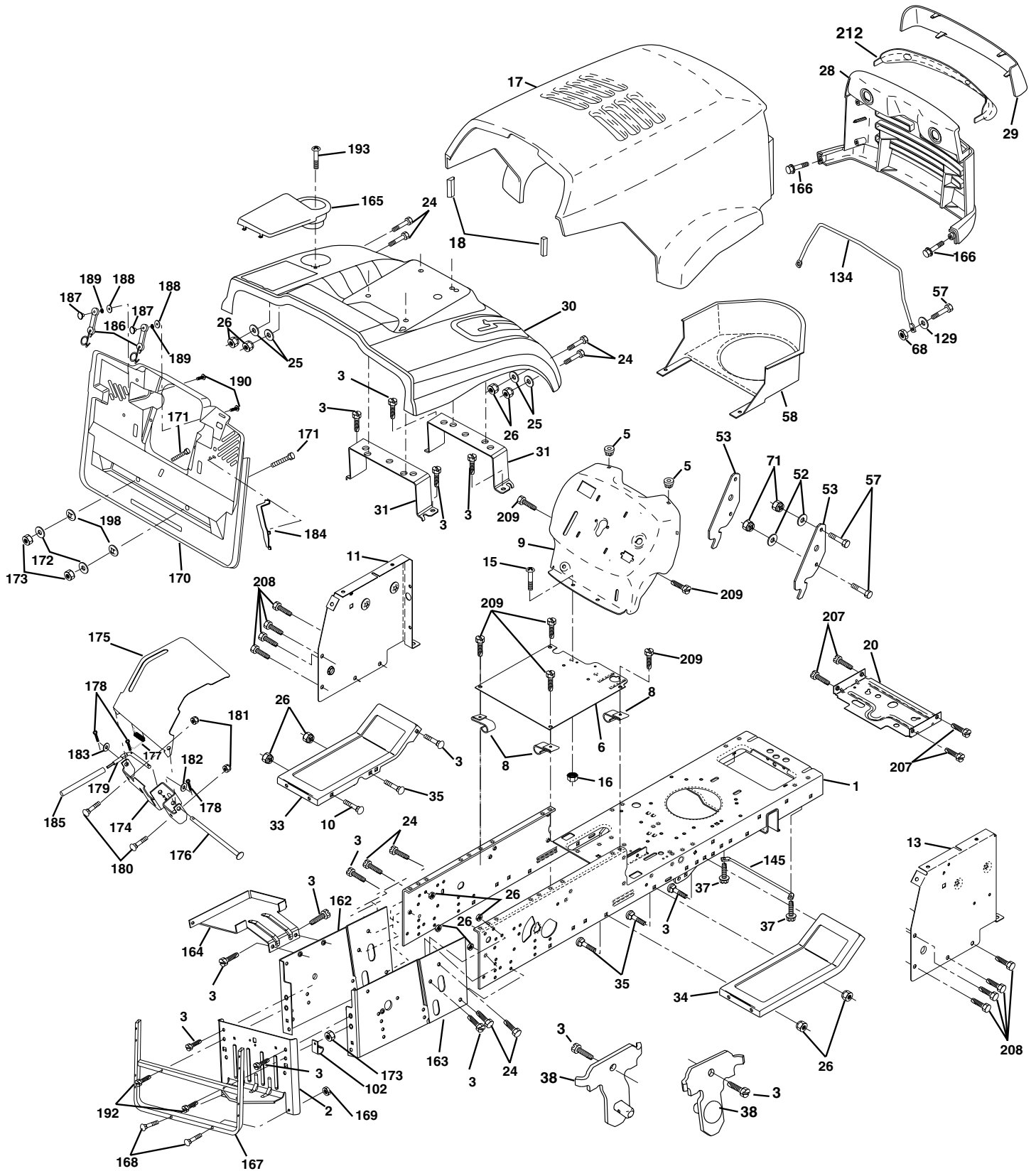

REPAIR PARTS

TRACTOR- -MODEL NO. CT150 (HECT150C) PRODUCT NO. 954 17 00-19 CHASSIS AND ENCLOSURES

KEY NO.	PART NO.	DESCRIPTION	KEY NO.	PART NO.	DESCRIPTION
1	532169831	Chassis Stamping	163	532165673	Bracket Exten Chassis Rh CRD
2	532165606	Drawbar	164	532165605	Support Battery CRD
3	817060612	Screw 3/8-16 x 3/4	165	532167979	Cover Battery CRD Lt
5	532155272	BumperHood/Dash	166	532164863	Screw Hwhd Hi-Lo #13-16 x 3/4
6	532155923	Saddle	167	532165779	Support Asm. Backplate WLDMNT
8	532126471	Clip Insulator 13/32 Mtg. Hole	168	872050412	Bolt, RDHD SHT NK 1/4-20 x 1-1/2
9	532171796	Dash	169	532123976	Nut, Lock 1/4 LGE FLG Gr. 5 Zinc
10	872140608	Bolt, Carriage 3/8-16 x 3/4	170	532175264	Backplate Asm CRD
11	532155927	Panel, Dash, L.H.	171	874520640	Bolt Hex 3/8-16 x 2-1/2
13	532172108	Panel, Asm. Dash R.H.	172	819132016	Washer 13/32 x 1-1/4 x 16 Ga.
15	874180512	Screw, Machine, Truss Head 5/16-18 UNC x 3/4	173	873510600	Nut, Keps Hex 3/8-16 UNC
16	873510500	Nut	174	532165939	Bracket Switch FBI CRD
17	532165378	Hood Assembly	175	532166212	Guard Door Rear CRD
18	532126938	BumperHood	176	532128600	Pin Hinge Pivot
20	532156437	Plate Mtg. Battery/Fuel Tank	177	532132796	Spring Bagger Top LH Black
24	874780616	Bolt	178	876020312	Pin Cotter 3/32 x 3/4 Cad Zinc
25	819131312	Washer 13/32 x 13/16 x 12 Gauge	179	532165942	Rod Pivot FBI CRD
26	873800600	Nut	180	874760516	Bolt Hex HD 5/16-18 UNC x 1
28	532165379	Grille PL	181	873680500	Nut Crownlock 5/16-18
29	532165380	Lens, Grille	182	532138200	Washer .385 x .625 x 11 Ga.
30	532168428	Fender	183	819131316	Washer 13/32 x 13/16 x 16 Ga.
31	532165156	Bracket, Fender Support	184	532174662	Bracket Actuator Bagger CRD
33	532147203	Footrest, L.H.	185	532165940	Tube Lever Switch FBI CRD
34	532147202	Footrest, R.H.	186	532160793	Latch Asm Mulch/Bagger
35	872110606	Bolt	187	532125004	Nut Weld
37	817490508	Screw Thdrol 5/16-18 x 1/2 TYT	188	819061216	Washer #10
38	532169834	Bracket Asm Pivot Mower Rear	189	810071000	Washer Lock #10
52	819091416	Washer 9/32 x 7/8 x 16 Ga.	190	871081010	Screw, Pan Hd Phillips 10-24 x 5/8
53	532150067	Bracket Pick off LT/PI Husq	192	817060624	Screw Thdrol 3/8-16 x 1-1/2
57	874780412	Bolt, Fin Hex 1/4-20 UNC x .75	193	817070412	Screw Truss 1/4-20 x 3/4
58	532150127	Duct Air Engine PI/Lt	198	532168937	Nut Push
68	873510400	Nut Keps Hex 1/4-20 Unc	207	817670508	Screw Thdrol 5/16-18 x 1/2
71	873680400	Nut Crownlock 1/4-20 Unc	208	817670608	Screw Thdrol 3/8-16 x 1/2
102	532124996	Clip Line Fuel 13-13/32 Mtg. Hole	209	817000612	Screw Hex Washer Thdr. 3/8-16 x 3/4
129	819091016	Washer 9/32 x 5/8 x 16 Ga.	212	532156195	Insert Lens Reflective
134	532160219	Rod Support Hood Husq P/L	- -	532005479	Plug, Button
145	532156524	Rod Pivot Chassis/Hood			
162	532170256	Bracket Exten Chassis Lh CRD			

NOTE: All component dimensions given in U.S. inches.
1 inch = 25.4 mm.

REPAIR PARTS

TRACTOR- -MODEL NO. CT150 (HECT150C) PRODUCT NO. 954 17 00-19
DRIVE

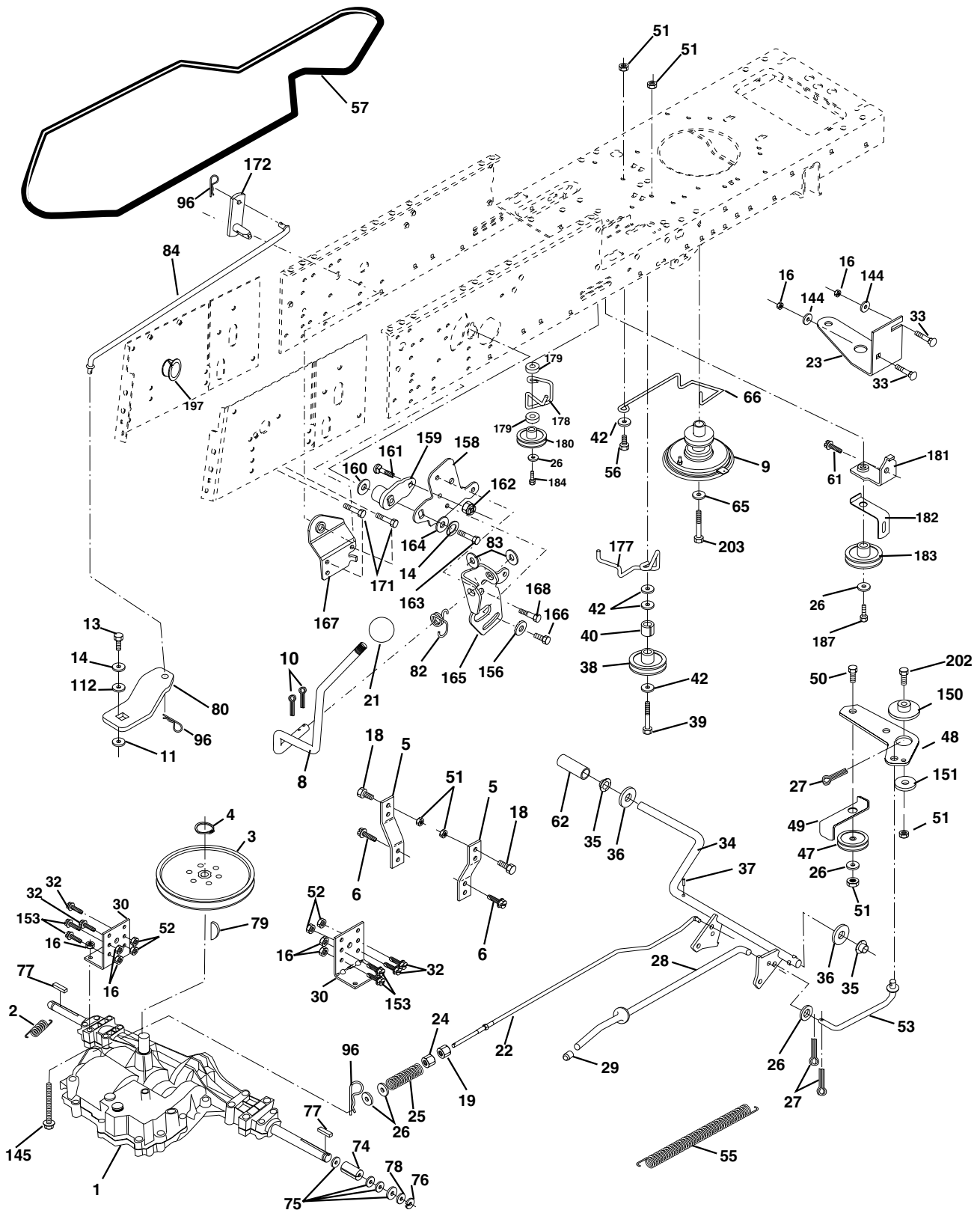

REPAIR PARTS

TRACTOR- -MODEL NO. CT150 (HECT150C) PRODUCT NO. 954 17 00-19
DRIVE

KEY NO.	PART NO.	DESCRIPTION	KEY NO.	PART NO.	DESCRIPTION
1	-----	Transaxle Peerless 206-546 (Order parts from transaxle manufacturer)	62	532123533	Cover, Pedal
2	532146682	Spring Brake Return	65	810040700	Washer
3	532165999	Pulley Transaxle	66	532154778	Keeper, Belt Engine F-Proof
4	812000028	Ring Retainer #5100-62	74	532137057	Spacer Axle
5	532121520	Strap torque 30 degrees	75	532121749	Washer 25/32 x 1-1/4 x 16 Ga.
6	817060512	Screw 5/16-18 x 3/4	76	812000001	Ring, E
8	532165619	Rod Shift Fender Adjust Lt	77	532123583	Key, Square
9	532170163	Clutch Asm Noram	78	532121748	Washer 25/32 x 1-5/8 x 16 Ga.
10	876020416	Pin, Cotter 1/8 x 1	79	532125096	Key Woodruff
11	532105701	Washer Plate Shf .3888 sq hole	80	532145090	Arm Shift PMST 20" Tires
13	874550412	Bolt 1/4-28 Unf Gr 8 w/patch	82	532123782	Spring, Torsion
14	810040400	Washer, Lock Hvy Helical	83	819171216	Washer 17/32 x 3/4 x 16 Ga.
16	873800500	Nut, Lock Hex w/Ins 5/16-18 UNC	84	532165621	Link Shift CRD Pmst 18" Tires
18	874780616	Bolt Hex 3/8-16 UNC x 1 Gr.5	96	532124788	Spring, Retainer 1"
19	873800600	Nut, Lock Hex w/Wsh 3/8-16 UNC	112	819091210	Washer 9/32 x 3/4 x 10 Ga.
21	532121274	Knob	144	819111016	Washer 11/32 x 5/8 x 16
22	532165811	Rod, Brake CRD 0650	145	874490540	Bolt Hex FGHD 5/16-18 x Gr 5
23	532170017	Bracket Asm Clutch Noram	150	532165850	Bushing, Bellcrank Grnd Dr
24	873350600	Nut	151	819133210	Washer 13/32 x 2 x 10 Ga.
25	532106888	Spring, Rod, Brake	153	874760516	Bolt Hex Hd 5/16-18 Unc x 1
26	819131316	Washer 13/32 x 13/16 x 16 Ga.	156	532166002	Washer Srrd 5/16 ID x 1.125
27	876020412	Pin, Cotter 1/8 x 3/4	158	532165589	Bracket Shift Mount
28	532145204	Rod, Parking Brake	159	532165494	Hub Tapered Flange Shift Lt
29	532071673	Cap, Parking Brake	160	819292016	Washer 29/32 x 1-1/4 x 16
30	532174973	Bracket, Mfg. Transaxle	161	872140406	Bolt Rdhd Sqnk 1/4-20 x 3/4 Gr 5
32	874760512	Bolt Hex 5/16-18 UNC x 3/4	162	873680400	Nut Crownlock 1/4-20 Unc
33	872140516	Bolt Rdhd Sqnk 5/16-18 Unc x 3/4	163	874780416	Bolt Hex Fin 1/4-20 Unc x 1 Gr 5
34	532165496	Shaft, Asm Pedal Foot CRD	164	819091010	Washer 5/8 x .281 x 10 Ga.
35	532120183	Bearing, Nylon	165	532165623	Bracket Pivot Lever
36	819211616	Washer 21/32 x 1 x 16 Ga.	166	532166880	Screw 5/16-18 x 5/8
37	532124963	Pin, Roll 3/16 x 1"	167	532165588	Bracket Support Shift CRD
38	532165936	Pulley, Flat	168	532165492	Bolt Shoulder 5/16-18 x .561
39	874760644	Bolt Fin Hex 3/8-16 Unc x 2-3/4	171	817490608	Screw Thdrol 3/8-16 x 1/2 Ty-Tt
40	532124965	Spacer, Split 395 x 59 Bzp	172	532165635	Shaft Asm Shift Front CRD PMST
42	819131312	Washer 13/32 x 13/16 x 12 Ga.	177	532165932	Keeper Flat Idler 3.06" CRD
47	532127783	Pulley, Idler, V Groove Plasic	178	532165933	Keeper Belt Idler 1.88" CRD
48	532154407	Bellcrank Clutch Grnd Drv	179	532120958	Washer Sintered
49	532123205	Retainer, Belt Style Spring	180	532165630	Pulley Flat Composite 3.06"
50	874760624	Bolt Hex Hd 3/8-16 UNC x 1-1/2	181	532165797	Bracket Idler Ground Drive CRD
51	873680600	Nut, Crownlock 3/8-16 UNC	182	532165634	Keeper Belt 2.5" Od V-Idler CRD
52	873680500	Nut Crownlock 5/16-18	183	532165626	Pulley V-Idler 2.50" Od CRD
53	532105710	Link, Clutch 7.66	184	817490644	Screw Hexwsh Thdrol 3/8-16 x 2-3/4
55	532105709	Spring, Return, Clutch	187	817490620	Screw Thdrol 3/8-16 x 1-1/4
56	874760620	Bolt, Hex 3/8-16 UNC x 1-1/4	197	532169613	Nyliner Snap-In 5/8
57	532165631	V-Belt Kev PMST CRD	202	872110612	Bolt Carr Sh 3/8-16 x 1-1/2 Gr. 5
61	817060612	Screw 3/8-16 x 3/4	203	871170780	Bolt Hex 7/16-20 x 5

NOTE: All component dimensions given in U.S. inches
1 inch = 25.4 mm

REPAIR PARTS

TRACTOR- -MODEL NO. CT150 (HECT150C) PRODUCT NO. 954 17 00-19 STEERING ASSEMBLY

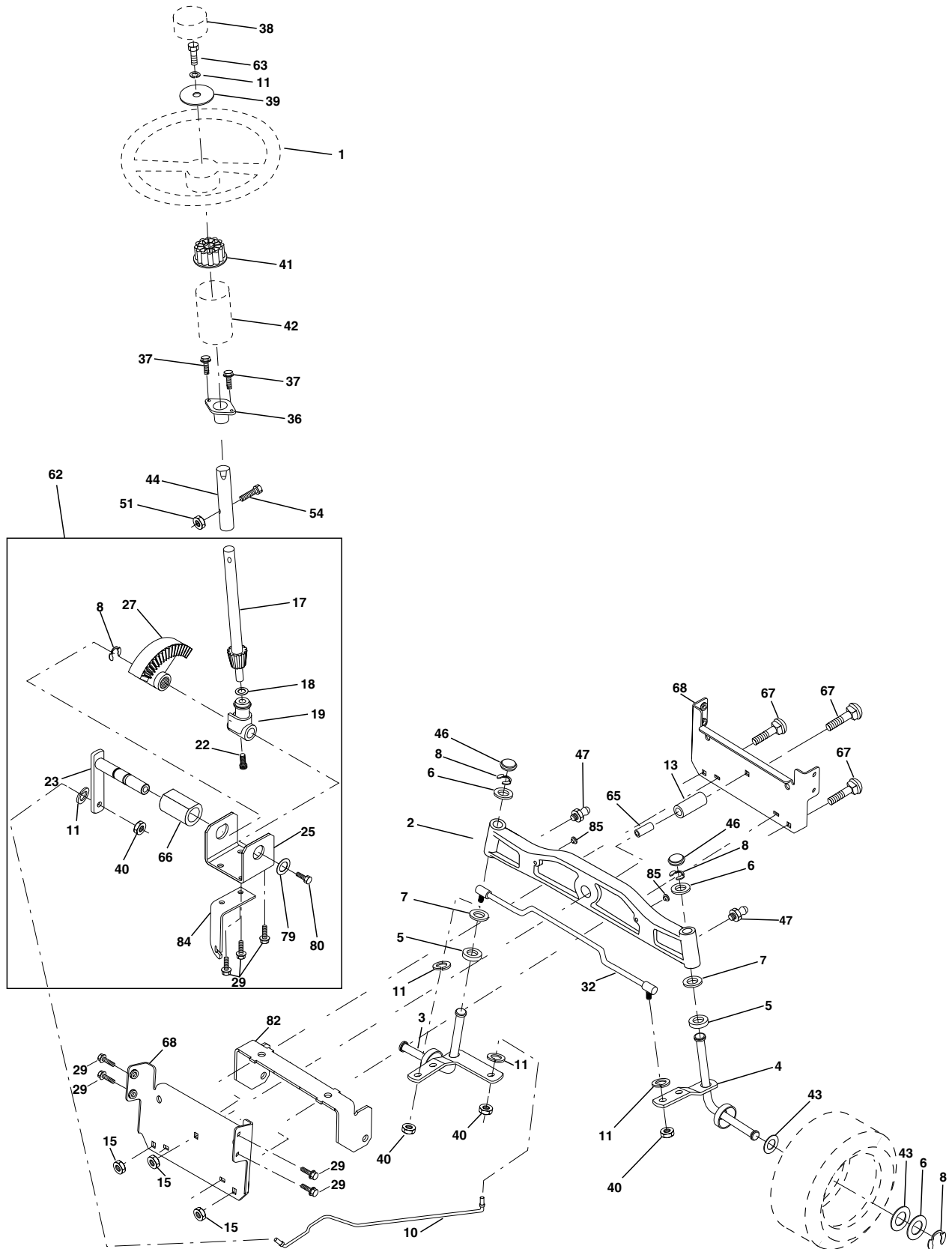

REPAIR PARTS

TRACTOR- -MODEL NO. CT150 (HECT150C) PRODUCT NO. 954 17 00-19
STEERING ASSEMBLY

KEY NO.	PART NO.	DESCRIPTION
1	532166627	Steering Wheel
2	532172393	Axle Asm. Cast Iron Lt
3	532169840	Spindle Assembly, L.H.
4	532169839	Spindle Assembly, R.H.
5	532124931	Bearing, Race, Thrust, Hardened
6	532121748	Washer 25/32 x 1-5/8 x 16 Gauge
7	819272016	Washer 27/32 x 1-1/4 x 16 Gauge
8	812000029	Ring, Klip
10	532169832	Link, Drag
11	810040600	Washer, Lock
13	532136518	Spacer Brg Axle Front
15	532145212	Nut Hex Flange Lock
17	532156546	Shaft Assembly, Steering
18	532057079	Washer, Thrust .515 x .750 x .033
19	532160395	Support, Shaft
22	532165857	Screw Hex Wshhd Torx
23	532165851	Pittman Shaft Assembly
25	532154406	Bracket, Steering
27	532136874	Gear, Sector
29	817060612	Screw 3/8-16 x 3/4
32	532170162	Rod, Tie
33	819111216	Washer 11/32 x 3/4 x 16
34	810040500	Washer Lock Hvy HLCL Spr.5/16
35	873540500	Crownlock Nut 5/16-24 UNF 3847
36	532155099	Bushing, Steering
37	532152927	Screw TT #10-32 x 5 x 3/8 Flange
38	532166626	Cap Wheel Steering
39	819132411	Washer 13/32 x 1-1/20 x 11 Gauge
40	532124701	Nut Lock Center 3/8-24 Unf
41	532159945	Adaptor, Steering Wheel
42	532169634	Boot, Steering Dash P/L Mtl
43	532121749	Washer 25/32 x 1-1/4 x 16 Gauge
44	532153720	Extension Steering Non-Adjust
46	532121232	Cap, Spindle
51	873800500	Nut Lock Hx W/Ins 5/16-18 UNC
54	874780520	Bolt Fin Hex 5/16-18 UNC x 1-1/4
62	532167902	Kit, Steering Assembly, Service
63	874780616	Bolt Fin Hex 3/8-16 unc. x 1 Gr. 5
65	532160367	Spacer Brace Axle
66	532154404	Bearing Arm Pittman
67	872140618	Bolt Rdhd Sqnk 3/8-16 x 2-1/4
68	532169827	Brace Axle
79	819132012	Washer 13/32 x 1-1/4 x 12 Ga
80	874950612	Bolt Hex Nylon 3/8-16 x 3/4
82	532169835	Bracket Susp Chassis Front
84	532170016	Bracket Cable Clutch Chassis
85	532133835	Fastner Christmas Tree
86	532165898	Retainer Spring Yellow
87	532173966	Washer Flat .781 x 1-1/2 x .14

NOTE: All component dimensions given in U.S. inches.
1 inch = 25.4 mm.

REPAIR PARTS

TRACTOR- -MODEL NO. CT150 (HECT150C) PRODUCT NO. 954 17 00-19
SEAT ASSEMBLY

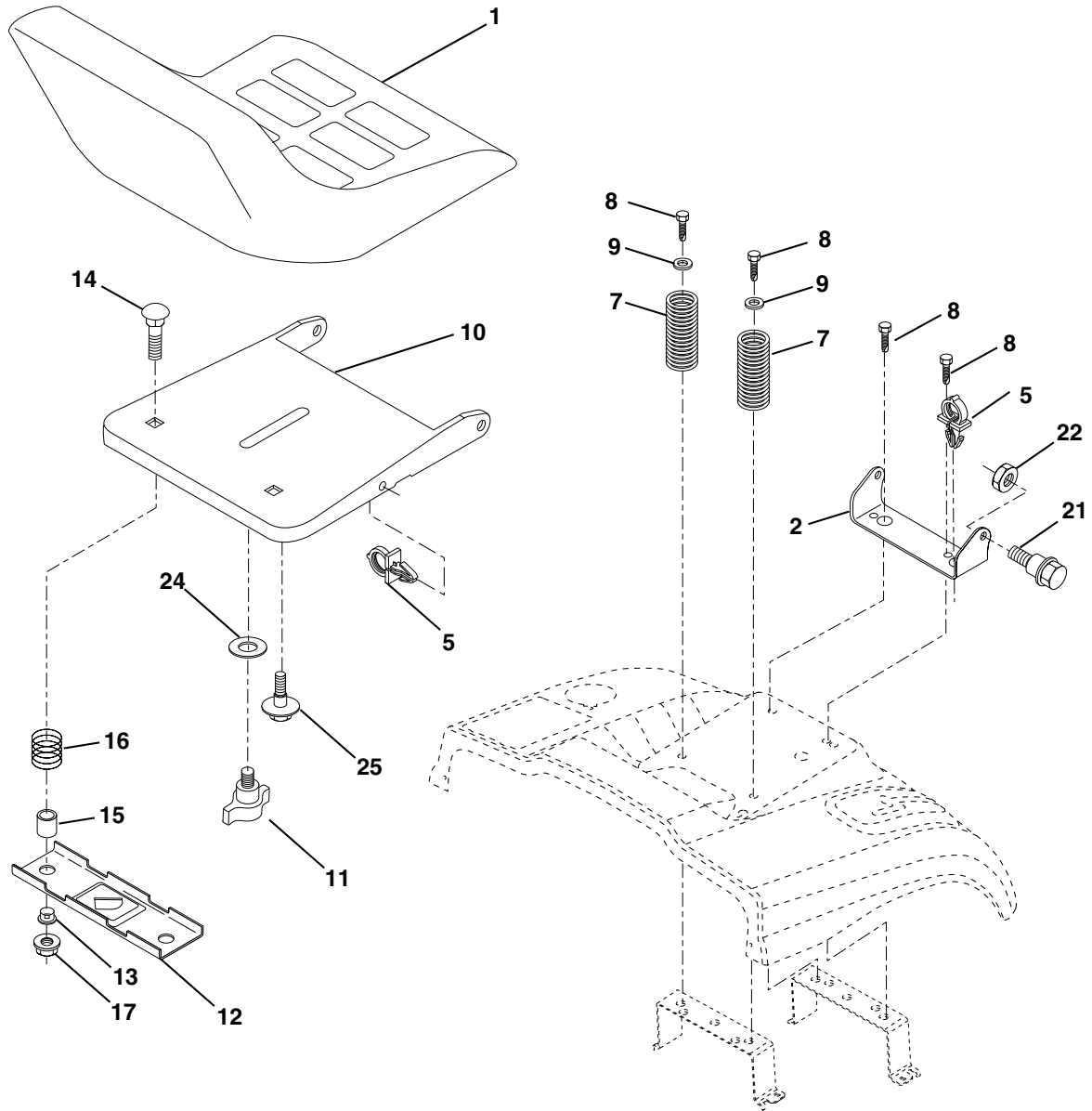

KEY NO.	PART NO.	DESCRIPTION
1	532140839	Seat
2	532140551	Bracket Pnt Pivot Seat (blk)
5	532145006	Clip Push In Hinged
7	532124181	Spring Seat Cprsn 2 250 Blk Zi
8	817000616	Screw 3/8-16 x 1
9	819131614	Washer 13/32 x 1 x 14 Ga
10	532174894	Pan Pnt Seat (blk)
11	532166369	Knob Seat Adj. Wingnut
12	532121246	Bracket Pnt Mounting Switch
13	532121248	Bushing Snap Blk Nyl 50 Id

KEY NO.	PART NO.	DESCRIPTION
14	872050412	Bolt Rdhd Sht Nk 1/4-20 x1-1/2
15	532134300	Spacer Split
16	532121250	Spring Cprsn Plate SW 1.310 Ga
17	532123976	Nut Lock 1/4 Lge Flg Gr 5 Zinc
21	532171852	Bolt Shoulder 5/16-18 Unc-2A
22	873800500	Nut Hex Lock w/Ins 5/16-18
24	819171912	Washer 17/32 x 13/16 x 12
25	532127018	Bolt Shoulder 5/16-18 x 62

NOTE: All component dimensions given in U.S. inches.
1 inch = 25.4 mm

REPAIR PARTS

TRACTOR- -MODEL NO. CT150 (HECT150C) PRODUCT NO. 954 17 00-19

DECALS

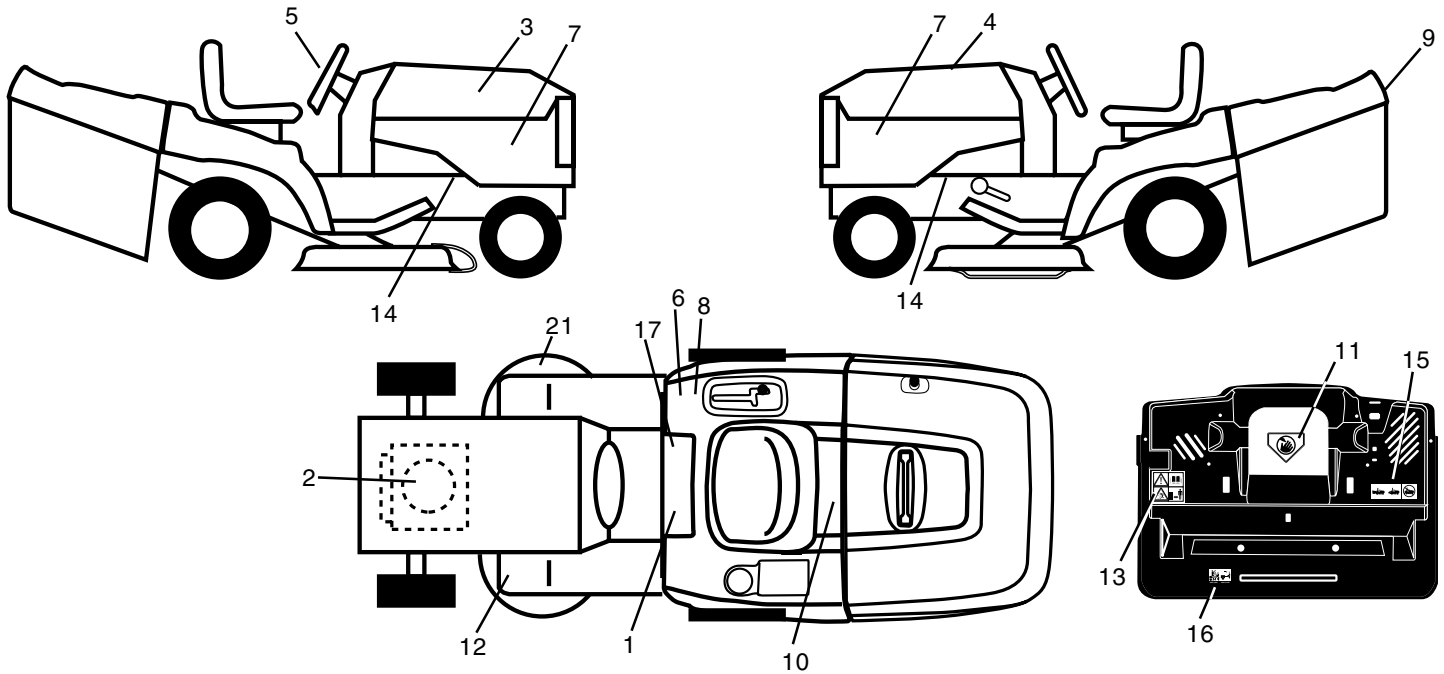

KEY NO.	PART NO.	DESCRIPTION
1	532145498	Decal Read Owner's Manual Sym
2	532170846	Decal Hp Engine
3	532170701	Decal Hood Rh
4	532170702	Decal Hood Lh
5	532170564	Decal Wheel Logo
6	532126187	Decal 100 DBA
7	532159713	Decal Panel Side
8	532145437	Decal Europe Stand Ce
9	532150617	Decal Fender Logo
10	532145005	Decal Bat Dan/Poi P/L Sym Wpn

KEY NO.	PART NO.	DESCRIPTION
11	532145494	Decal Mower Cut Finger Symbol
12	532159737	Decal Brake/Clutch Symbol Lt
13	532166959	Decal Warn Back Plate CRD
14	532159736	Decal Chassis Hot Muffler
15	532166961	Decal Oper Bag Presence CRD
16	532162598	Decal Drawbar Load Limit
17	532140837	Decal Saddle Brake Parking
21	532166286	Decal Deck Sch 92 CRD
—	532138311	Decal Lift Handle
—	532171237	Pad Footrest
—	532175613	Manual Operator's (Euro)
—	532175614	Manual Operator's (Scand)

WHEELS & TIRES

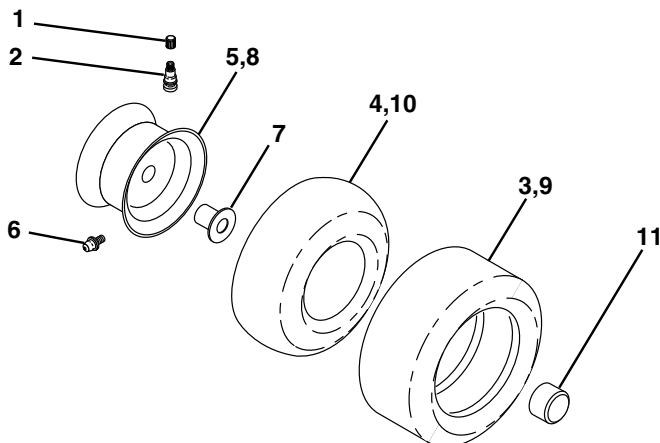

KEY NO.	PART NO.	DESCRIPTION
1	532059192	Cap Valve Tire
2	532065139	Stem Valve
3	532106222	Tire F Ts 15 X 6 0 - 6 Service
4	532059904	Tube Inner Front #35060
5	532138336	Rim Asm 6"front White Service
6	532124957	Fitting Grease
7	532124959	Bearing Flange
8	532138337	Rim Asm 8"rear White Service
9	532124635	Tire R Ts 18 x 8.5-8 Service
10	532124926	Tube Rear 9 5 X 8 Service
11	532104757	Cap Axle Blk 1 50 X 1 00 x 428
--	532144334	Sealant, Tire (10 oz. tube)

NOTE: All component dimensions given in U.S. inches
1 inch = 25.4 mm

REPAIR PARTS

TRACTOR- -MODEL NO. CT150 (HECT150C) PRODUCT NO. 954 17 00-19
ENGINE

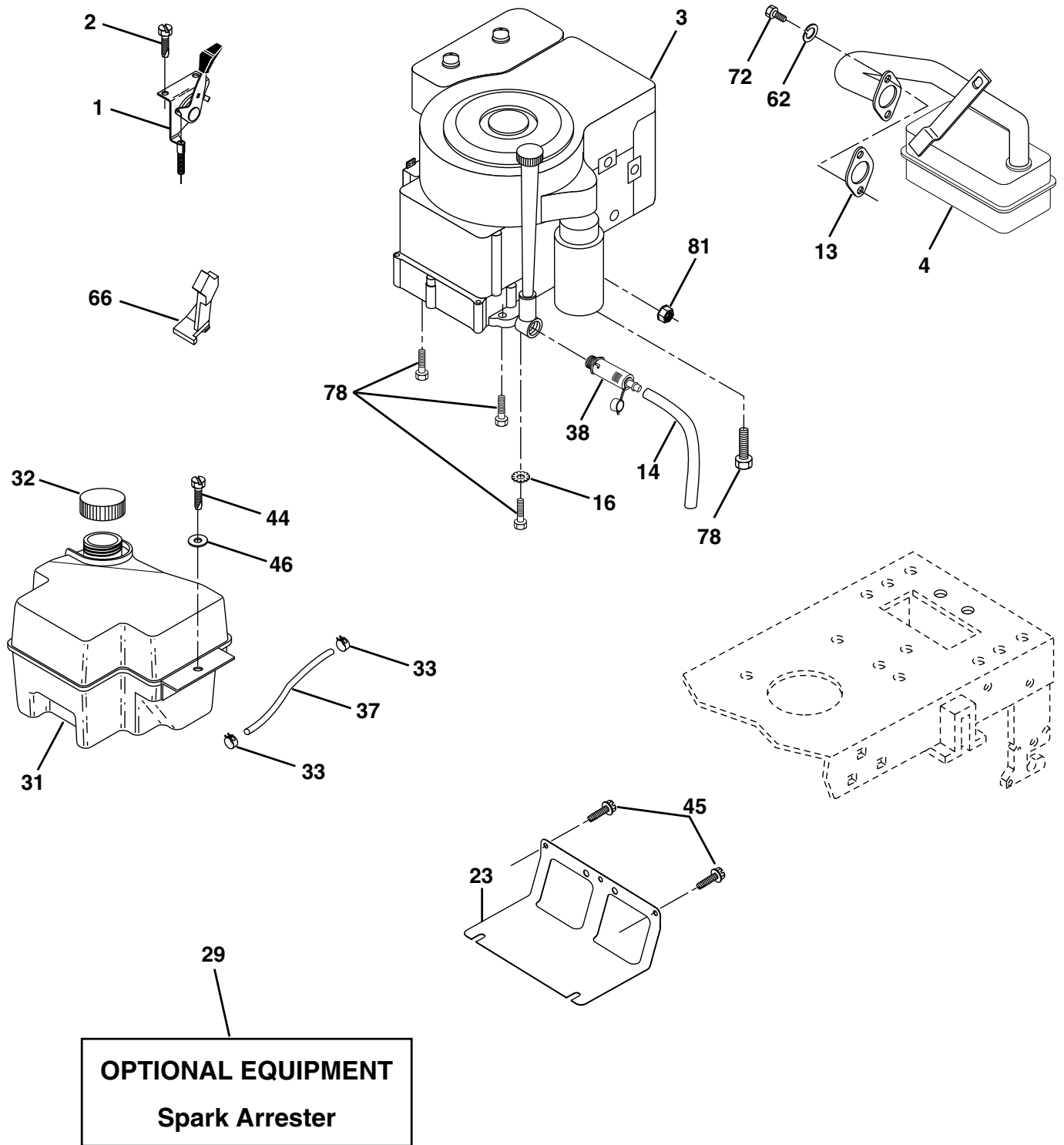

REPAIR PARTS

TRACTOR- -MODEL NO. CT150 (HECT150C) PRODUCT NO. 954 17 00-19
ENGINE

KEY NO.	PART NO.	DESCRIPTION
1	532170865	Control Throt /Ch Flag B&S EEC
2	817720410	Screw Hex Thd Cut 1/4-20x5/8 T
3	-----	Engine Briggs Model 287707 (Order Parts from Engine Manufacturer)
4	532137352	Muffler Exhaust B&S Lt
13	532165291	Gasket 1 313 Id Tin Plated
14	532148456	Tube Drain Oil Easy
16	811050600	Washer Lock Ext Tooth 3/8
23	532169837	Shield Browning/Debris Guard
29	532137180	Arrestor Spark
31	532161911	Tank Fuel 2.00 Fr
32	532140527	Cap Asm Fule Top Vent N/Lany
33	532123487	Clamp Hose Blk
37	532137040	Line Fuel 20"
38	532148315	Plug Drain Oil Easy
44	817670412	Screw Hexwsh Thdrol 1/4-20 x 3/4
45	817000612	Screw Hexwsh 3/8-16 x 3/4
46	819091416	Washer 9/32 X 7/8 X 16ga
62	810040500	Washer Lock Hvy Hlcl Spr 5/16
66	532127951	Stop Throttle 3000 Rpm
72	871070512	Screw Hexhd Cap 5/16-18 x 5/8
78	817060620	Screw 3/8-16x1-1/4
81	873510400	Nut Keps 1/4-20

NOTE: All component dimensions given in U.S. inches
1 inch = 25.4 mm

REPAIR PARTS

TRACTOR- -MODEL NO. CT150 (HECT150C) PRODUCT NO. 954 17 00-19
MOWER LIFT

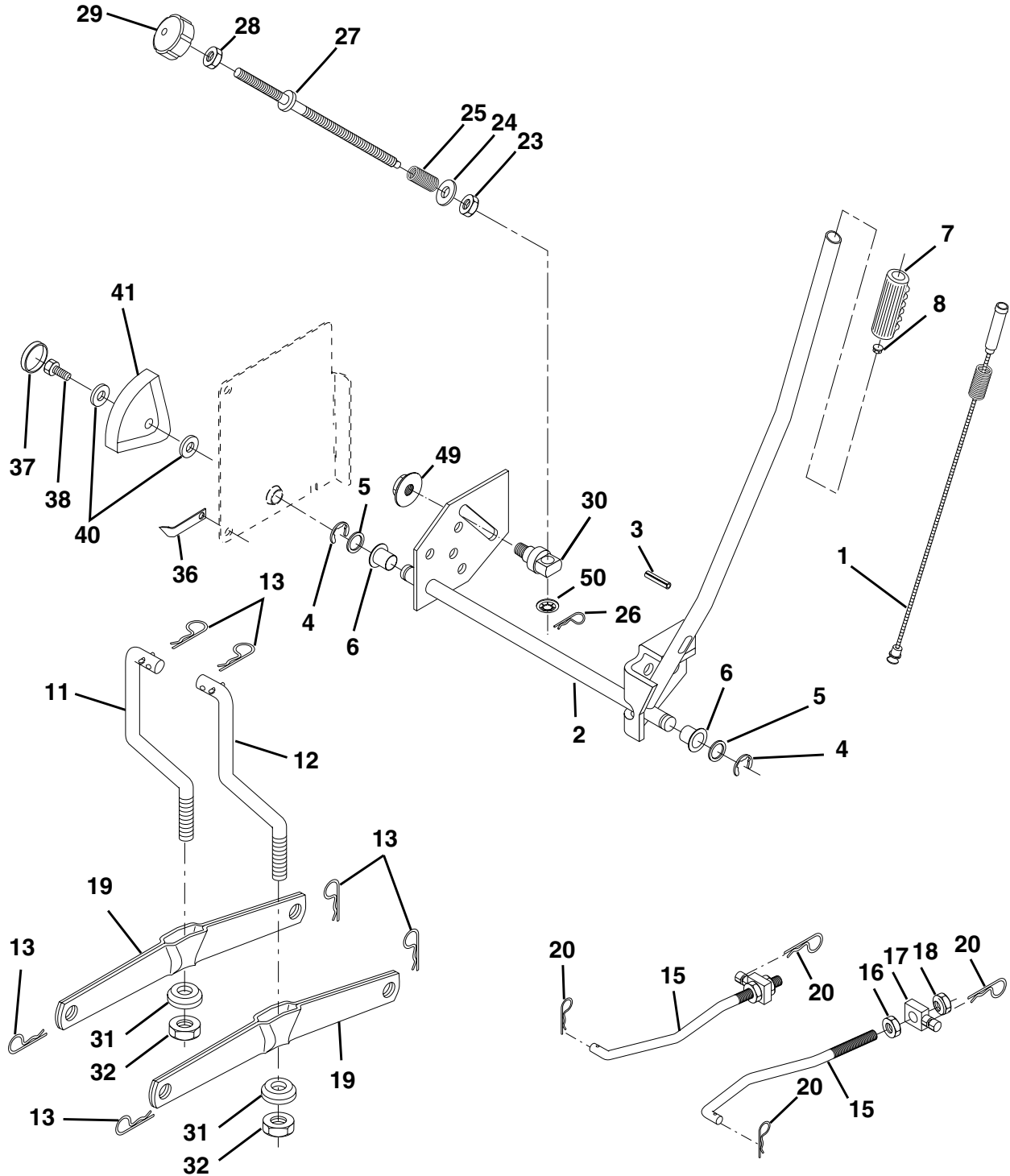

REPAIR PARTS

TRACTOR- -MODEL NO. CT150 (HECT150C) PRODUCT NO. 954 17 00-19
MOWER LIFT

KEY NO.	PART NO.	DESCRIPTION
1	532159460	Washer Asm Inner Spring W/Plunger
2	532159471	Shaft Asm. Lift
3	532105767	Pin Groove
4	812000002	E Ring #5133-62
5	819211621	Washer 21/32 x 1 x 21 Ga.
6	532120183	Bearing Nylon
7	532125631	Grip Handle
8	532124526	Button Plunger Black
11	532165829	Link Asm Lift L.H.
12	532165831	Link Asm Lift R.H.
13	532124670	Retainer Spring
15	532173288	Link Front Suspension
16	873350800	Nut Jam Hex 1/2-13 Unc
17	532130171	Trunnion Blk Zinc
18	873800800	Nut Lock W/Wsh 1/2-13 Unc
19	532139868	Arm Suspension Mower
20	532163552	Retainer Spring
23	532110807	Nut Special
24	819131016	Washer 13/32 x 5/8 x 16 Ga.
25	532124874	Spring 2-1/8
26	532169484	Retainer Clip
27	532126971	Rod Adj Lift Zinc
28	873350600	Nut Hex Jam 3/8-16 Unc
29	532138057	Knob Inf 3/8-16 unc
30	532150233	Trunnion Infin Height
31	532169865	Bearing, Pvt. Lift. Tapered
32	873540600	Nut Crownlock 3/8-24
36	532155097	Pointer Height Indicator
37	532123935	Plug Hole Blk
38	817060516	Screw 5/16-18 x 1
40	819112410	Washer 11/32 x 1-1/2 x 10 Ga
41	532123934	Scale Ind Height Blk
49	532145212	Nut Hex flange lock
50	532110452	Nut Push Phos &Oil

NOTE: All component dimensions given in U.S. inches
1 inch = 25.4 mm

REPAIR PARTS

TRACTOR- -MODEL NO. CT150 (HECT150C) PRODUCT NO. 954 17 00-19
MOWER

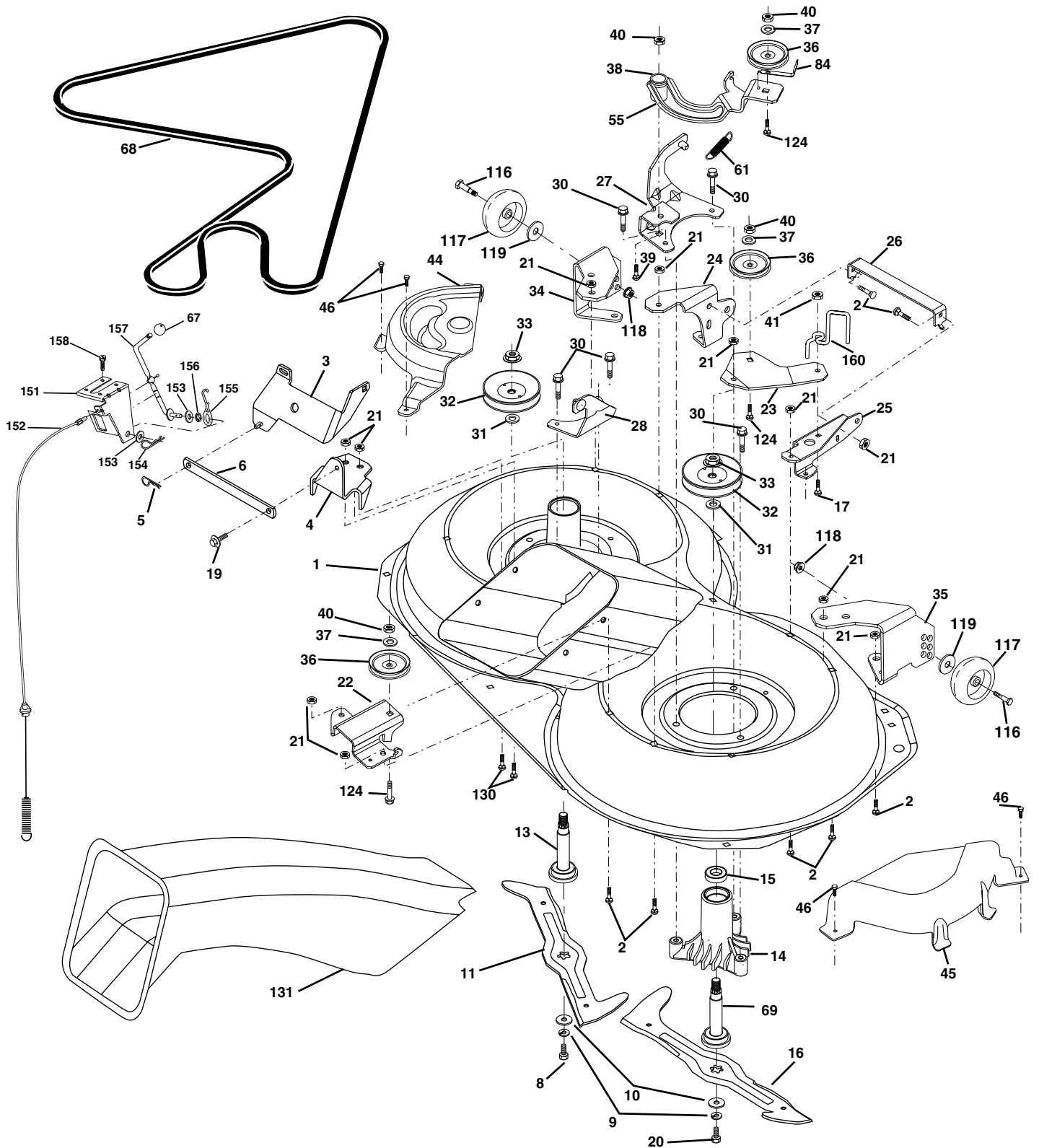

REPAIR PARTS

TRACTOR- -MODEL NO. CT150 (HECT150C) PRODUCT NO. 954 17 00-19
MOWER

KEY NO.	PART NO.	DESCRIPTION	KEY NO.	PART NO.	DESCRIPTION
1	532169160	Housing Asm. Mower 107 CRD	39	872110622	Bolt Rdhd 3/8-16 Unc x 2-3/4 Gr. 5
2	872140506	Bolt Rdhd Sqnk 5/16-18 Unc x 3/4	40	873680600	Nut Crownlock 3/8-16 Unc
3	532165569	Bracket Asm. S-Bar Chass 92 CRD	44	532169180	Cover Mandrel Lh 107 CRD
4	532169167	Bracket Bar Sway Deck 107 CRD	45	532169179	Cover Mandrel Rh 107 CRD
5	532124670	Retainer Spring	46	532137729	Screw Thd Roll 1/4-20 x 5/8
6	532165557	Bar Sway 92 CRD	55	532169849	Arm Idler 107 CRD
8	532850857	Bolt 3/8-24 x 1.25 Gr8 Patched	61	532175159	Spring Tension Belt
9	810030600	Washer Hard Hvy 3/8 Unplated	67	532106932	Knob Rd 3/8-16 Plstc Thds Blk
10	532140296	Washer Hard Blade Mower vented	68	532169178	Hex-Belt 107 Mower
11	532175450	Blade 3-1 Lh 107 CRD	69	532165482	Shaft Asm W/Lwr Brg Rh Thd CRD
13	532137645	Shaft Asm. W/Lower Bearing	84	532156085	Keeper Belt Idler
14	532128774	Housing Mandrel Vented (Machd)	116	532137644	Bolt Shoulder
15	532110485	Bearing Ball Mandrel	117	532133957	Wheel Gage Donut Wide
16	532175451	Blade 3-1 Rh 107 CRD	118	873930600	Nut Centerlock 3/8-16 Unc
18	872140508	Bolt Rdhd Sqnk 5/16 x 18Unc x 1	119	819121414	Washer 3/8 x 7/8 x 14 Ga.
19	532132827	Bolt Shoulder 5/16-18 Thd Form	124	872110612	Bolt Carr Sh 3/8-16 x 1-1/2 Gr5
20	532165484	Bolt 3/8-24 x 1.25 Gr8 Ptch Lhthd	130	872110506	Bolt Rdhdsqnk 5/16-18 Unc x 3/4
21	873680500	Nut Crown Lock 5/16-18	131	532165661	Chute Bagger CRD 92cm
22	532169165	Bracket Idler Sprt RR 107 CRD	151	532169670	Bracket Clutch Cable
23	532169166	Bracket Idler Sprt RF 107 CRD	152	532176074	Clutch Cable
24	532169170	Bracket Suspension LF 107 CRD	153	532169674	Washer Flat 3/8" Type B
25	532169171	Bracket Suspension RF 107 CRD	154	532169675	Spring Retainer
26	532165237	Brace Support Susp Frt CRD	155	532169671	Spring Retention Lvr Clutch Cable
27	532169172	Bracket Asm. Susp RR 107 CRD	156	532169672	Spacer Clutch Cable
28	532169168	Bracket Asm. Susp LR 107 CRD	157	532169669	Rod Clutch Cable 3/8"
30	532157722	Screw Thd Rolling Washer Head	158	817720410	Screw Hex Thd Cut 1/4-20 x 5/8
31	532129963	Washer Spacer Mower Vented	160	532175160	Belt Keeper
32	532175707	Mandrel Pulleys	--	532130794	Mandrel Asm Service
33	532137266	Nut Flg Top Lock Cntr B 9/16	--	532165579	Mandrel Asm CRD Lh Threads SVC
34	532169174	Bracket Gauge Wheel Lf 107 CRD	--	532170273	Deck Mower Complete
35	532169175	Bracket Gauge Wheel Rf 107 CRD			
36	532146763	Pulley Idler V-Groove Dim 4.25			
37	819131316	Washer 11/32 x 13/16 x 16 Ga			
38	532169851	Spacer Hub Arm Idler 107 CRD			

NOTE: All component dimensions given in U.S. inches
1 inch = 25.4 mm

REPAIR PARTS

TRACTOR- -MODEL NO. CT150 (HECT150C) PRODUCT NO. 954 17 00-19
BAGGER

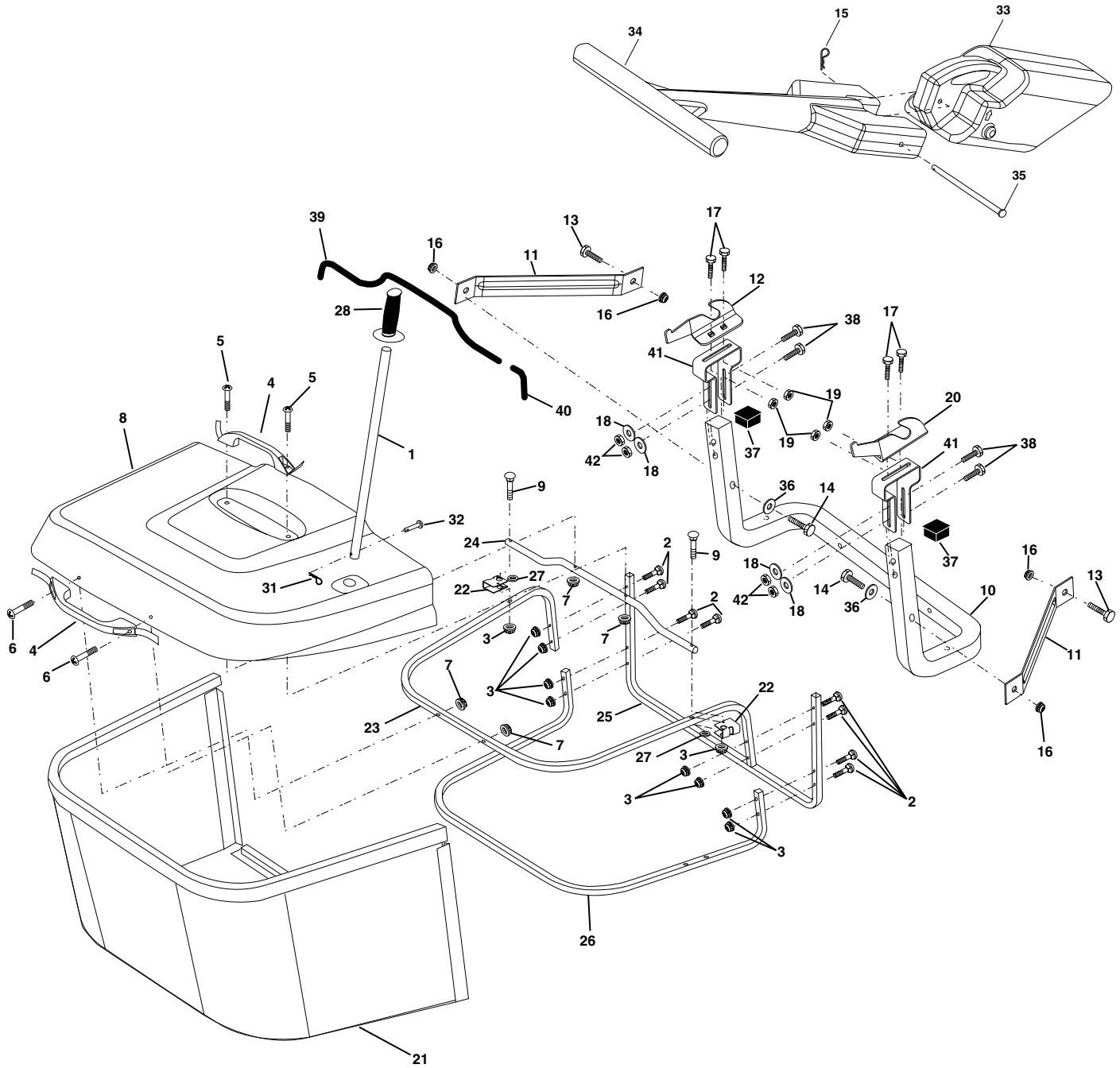

REPAIR PARTS

TRACTOR- -MODEL NO. CT150 (HECT150C) PRODUCT NO. 954 17 00-19
BAGGER

KEY NO.	PART NO.	DESCRIPTION
1	532170690	Tube Handle Bagger CRD
2	872140416	Bolt Carriage 1/4-20 x 2.0 Gr.5
3	532123976	Nut Lock 1/4 Lge Flg Gr. 5 Zinc
4	532169916	Handle Bagger w/Lvrs Blk CRD
5	874981024	Screw Pan Head #10-24 x 1.50 Blk
6	874981032	Screw Pan Hd
7	873401000	Nut Wiz Lock Hex Serr/Hd 10-24
8	532167980	Cover Bagger Plastic CRD MS422
9	872140418	Bolt Carriage 1/4-20 x 2.25d x Gr.5
10	532169688	Tube Support Bagger CRD
11	532165719	Bracket Support Upper Bag CRD
12	532169685	Bracket Horiz Adj Bagger Lh CRD
13	872110606	Bolt Rdhd Sht Sqnk 3/8-16 x 3/4
14	874520640	Bolt Hex 3/8-16 x 2-1/2 Gr.5
15	532124670	Retainer Spring
16	873900600	Nut Lock Flg 3/8-16 Unc
17	872140506	Bolt Rdhd Sht Sqnk 5/16 -18 Unc x 3/4
18	819111216	Washer 11/32 x 3/4 x 16
19	873900500	Nut Lock Hex Flange 5/16-18
20	532169684	Bracket Horiz Adj Bagger Rh CRD
21	532165780	Bag Asm CRD
22	532165781	Bracket Side Bagger CRD
23	532165782	Tube Upper Bagger CRD
24	532165783	Tube Pivot Bagger CRD
25	532165784	Tube Front Bagger CRD
26	532165785	Tube Lower Bagger CRD
27	532169692	Bushing Snap Bagger CRD
28	532170696	Grip Handle Black
31	532124788	Retainer Spring 1" Zinc/Cad
32	532126875	Rivet Rd Hd Drilled 3/8 Dia
33	532169380	Plug Mulcher 107 CRD
34	532165570	Handle Mulcher 92/107 CRD
35	532165572	Pin Mulcher 92/107 CRD
36	819132016	Washer 13/32 x 1-1/4 x 16 Ga.
37	532175401	Plug Support Bagger CRD
38	872010520	Bolt 5/16-18 x 2-1/2
39	532169999	Seal 26" (Long)
40	532170000	Seal 7" (Short)
41	532169683	Bracket Vert Adj Bagger CRD
42	873800500	Nut Lock Hex W/Ins 5/16-18 Unc PI

NOTE: All component dimensions given in U.S. inches
1 inch = 25.4 mm