

# YTH150

**Spare parts**  
**Ersatzteile**  
**Pièces détachées**  
**Reserve onderdelen**  
**Repuestos**  
**Reservdelar**

# REPAIR PARTS

TRACTOR - - MODEL NO. YTH150 (HFYTH155G) PRODUCT NO. 954 17 00-24  
ELECTRICAL

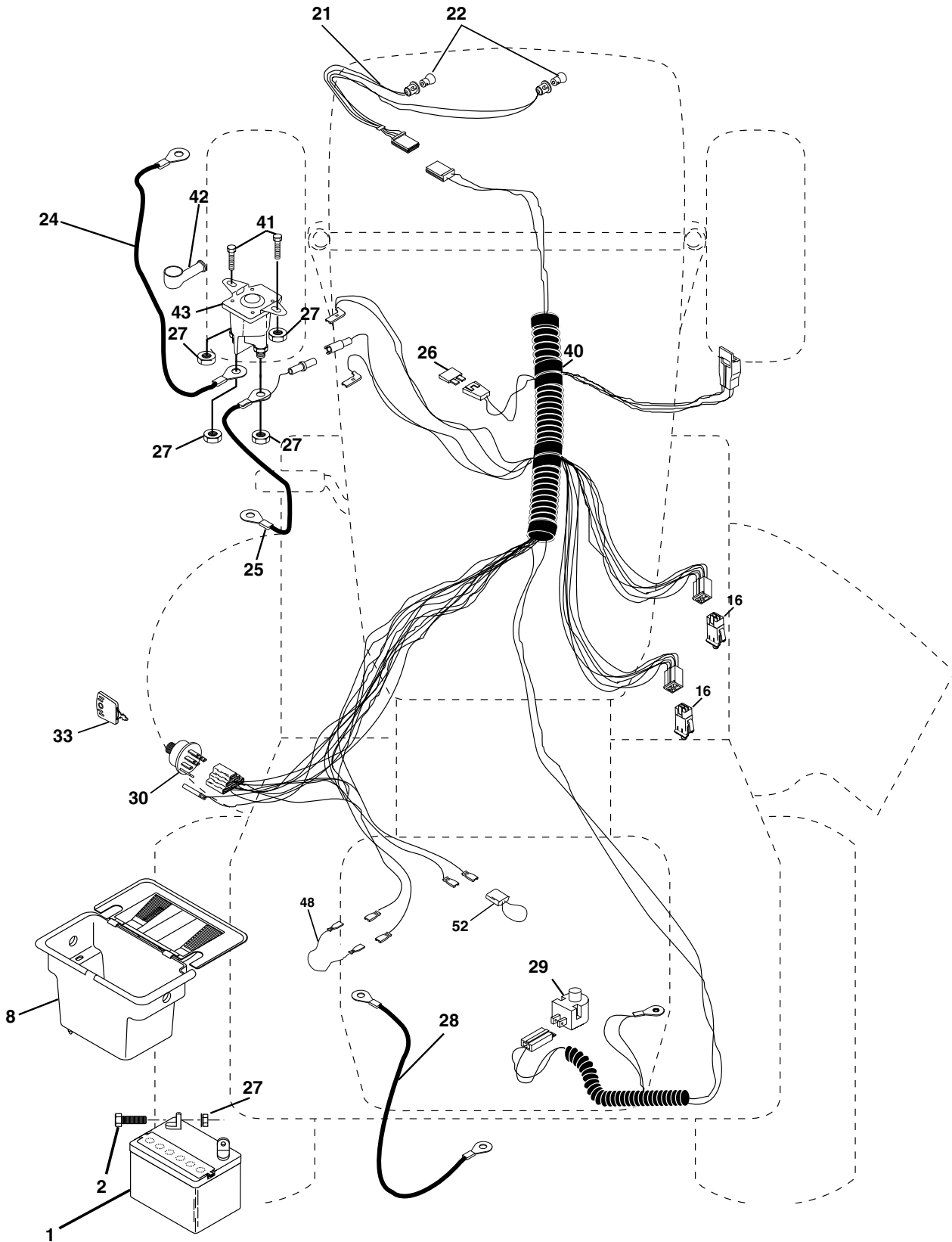

# REPAIR PARTS

TRACTOR - - MODEL NO. YTH150 (HFYTH155G) PRODUCT NO. 954 17 00-24  
ELECTRICAL

KEY NO.	PART NO.	DESCRIPTION
1	532144925	Battery 12 Volt 25 AMP
2	874760412	Bolt Hex Hd 1/4-20unc X 3/4
8	532156417	Case Battery w/2 Holes
16	532153664	Switch Interlock Push-In
21	532166181	Harness Asm Light W/4152j
22	532004152	Bulb Light #1156
24	532124780	Cable Battery 6 Ga 11" red
25	532146147	Cable Battery 6 Ga 44" red w/16 wire
26	<b>532175158</b>	Fuse
27	873510400	Nut Keps Hex 1/4-20 Unc
28	532124773	Cable Ground 6 Ga 12" black
29	532121305	Switch Plunger Nc Gray
30	<b>532175566</b>	Switch Ign
33	532140401	Key Ign Molded Generic
40	532170217	Harness Ign
41	871110408	Bolt Blk Fin Hex 1/4 - 20 x 1/2
42	532131563	Cover Terminal Red
43	<b>532175141</b>	Solenoid
48	532140844	Adapter Ammeter Rectangular
52	532141940	Protection Wire Loop

**NOTE:** All component dimensions given in U.S. inches.  
1 inch = 25.4 mm.

# REPAIR PARTS

TRACTOR - - MODEL NO. YTH150 (HFYTH155G) PRODUCT NO. 954 17 00-24  
CHASSIS AND ENCLOSURES

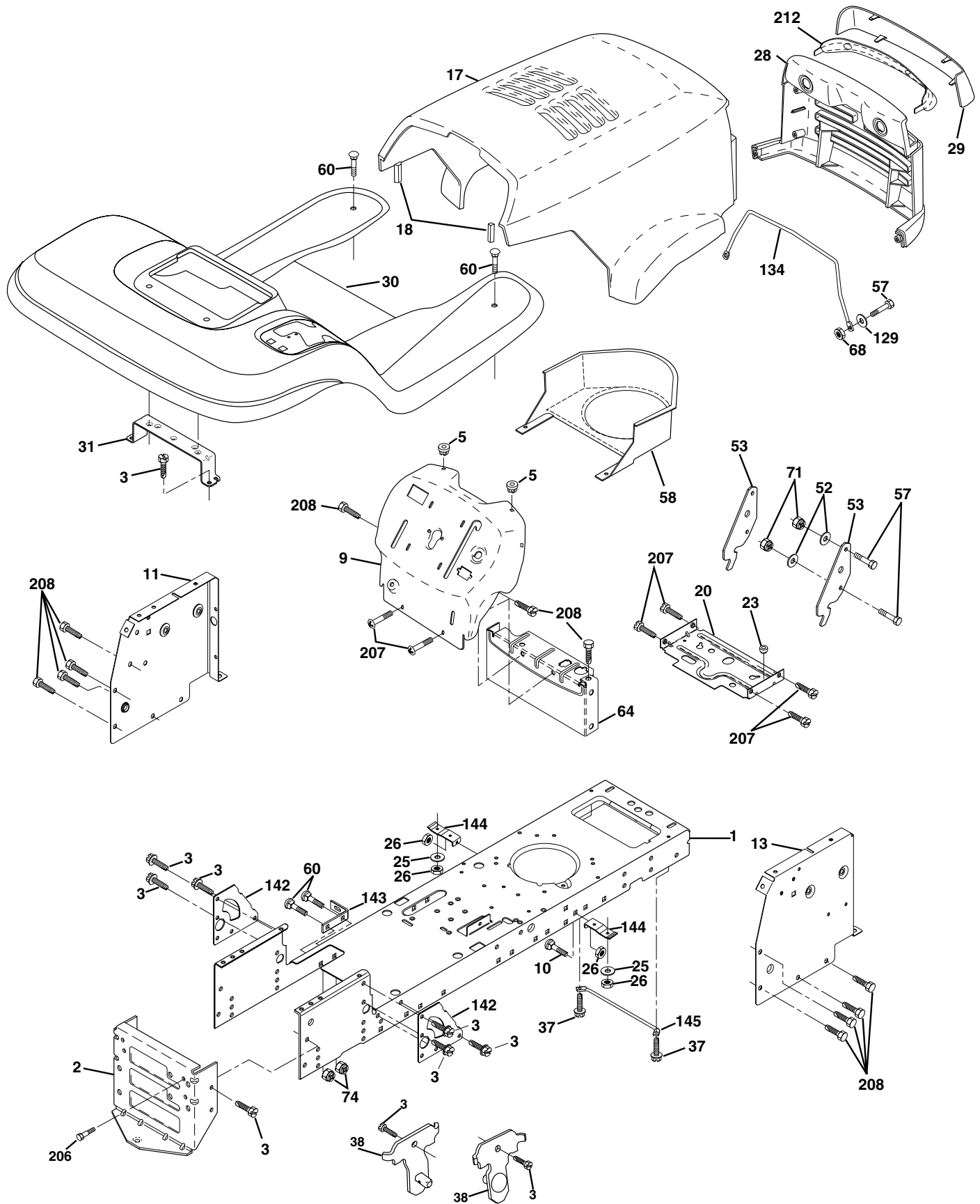

# REPAIR PARTS

## TRACTOR - - MODEL NO. YTH150 (HFYTH155G) PRODUCT NO. 954 17 00-24 CHASSIS AND ENCLOSURES

KEY NO.	PART NO.	DESCRIPTION
1	532169830	Chassis Weldment
2	532169061	Drawbar
3	817060612	Screw 3/8-16x3/4
5	532155272	Bumper Hood/Dash
9	532171853	Dash P/L
10	872140608	Bolt Carriage 3/8-16 x 1
11	532155927	Panel Dash Lh
13	532172108	Panel Dash Rh
17	532165378	Hood LT/PL Husqvarna
18	532126938	Bumper Hood
20	532156437	Plate Mtg Battery Fuel Tank Fr
23	532124028	Bushing
25	819131312	Washer 13/32 X 13/16 X 12 Ga
26	873800600	Nut Lock Hex W/Ins 3/8-16 Unc
28	532165379	Grille LT/PL Husqvarna
29	532165380	Lens LT/PL Husqvarna
30	532171854	Fender Footrest STLT Pnt
31	532139976	Bracket Support Fender
37	817490508	Screw Thdrol 6/16-18 x 1/2 TYT
38	532169834	Bracket, Asm. Pivot, Mower Rear
52	819091416	Washer 9/32 x 7/8 x 16 Ga.
53	532150067	Bracket Pnt. Pick off LT/PL Husqvarna
57	874780412	Bolt Hex 1/4-20 x 3/4
58	532150127	Air Duct Engine P/L
60	872140606	Bolt Rdhd Sqnk 3/8-16unc x 3/4
64	532154798	Dash Lower STLT
68	873510400	Nut Keps Hex 1/4-20 unc
71	873680400	Nut Crownlock 1/4-20 UNC
74	873680600	Nut Crownlock 3/8-16 UNC
129	819091016	Washer 9/32 x 5/8 x 16 Ga.
134	532160219	Rod Support Hood LT/PL Husq.
142	532165867	Plate Reinforcement STLT
143	532154966	Bracket Swaybar Chassis
144	532154207	Bracket Pnt Footrest STLT
145	532156524	Rod Pivot Chassis/Hood
206	532170165	Bolt Shoulder 5/16-18 TT
207	817670508	Screw Thdrol 5/16-18 x 1/2
208	817670608	Screw Thdrol 3/8-16 x 1/2
212	532156195	Insert Lens Reflective
--	532005479	Plug Button

**NOTE:** All component dimensions given in U.S. inches.  
1 inch = 25.4 mm

# REPAIR PARTS

TRACTOR - - MODEL NO. YTH150 (HFYTH155G) PRODUCT NO. 954 17 00-24  
DRIVE

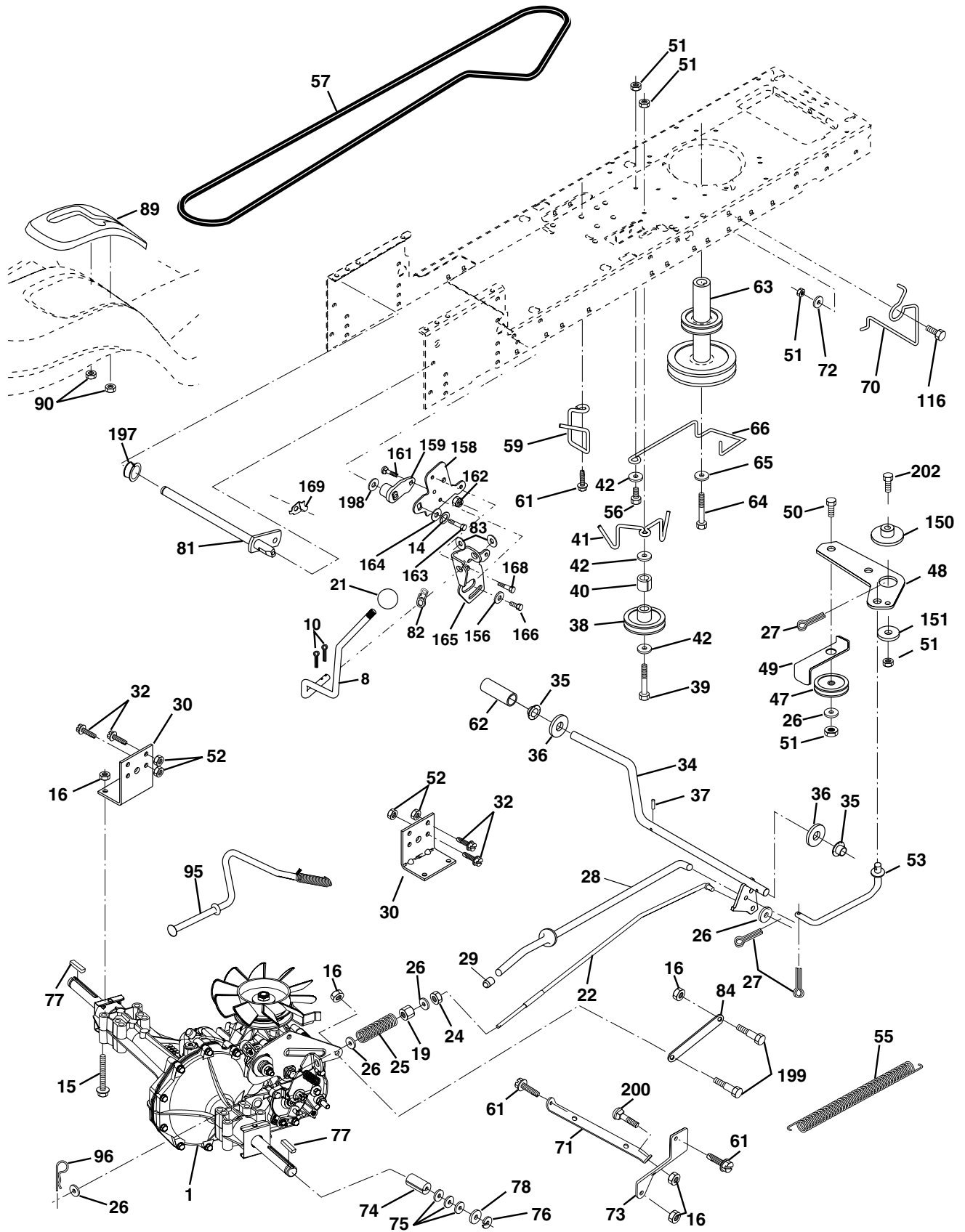

# REPAIR PARTS

TRACTOR - - MODEL NO. YTH150 (HFYTH155G) PRODUCT NO. 954 17 00-24  
DRIVE

## Correction:

**70 532134863**

KEY NO.	PART NO.	DESCRIPTION	KEY NO.	PART NO.	DESCRIPTION
1	-----	Transaxle Hydro Gear 314-0510 Order parts from transaxle manufacturer	63	532140186	Pulley, Engine
8	532165866	Rod Shift Fender	64	871170764	Bolt, Hex 7/16-20 x 4 Gr. 5
10	876020416	Pin Cotter 1/8 x 1 CAD	65	810040700	Washer
14	810040400	Washer Lock Hvy Helical	66	532154778	Keeper Belt Engine Hydro
15	874490544	Bolt Hex Flghd 5/16-18 Gr. 5	70	<b>532134863</b>	Guide Belt Mower Drive RH
16	873800500	Nut Lock Hex W/Ins.5/16-18 Unc P	71	532169183	Strap Torque Rh Hydro
19	873800600	Nut Lock Hex W/Wsh 3/8-16 Unc	72	819132012	Washer 13/32 x 1-1/4 x 12 Ga.
21	532121274	Knob Duckhead	73	532169182	Strap Torque Rh Hydro
22	532169498	Rod, Brake Hydro	74	<b>532137057</b>	Spacer, Axle
24	873350600	Locknut	75	532121749	Washer 25/32 x 1-1/4 x 16 Ga.
25	532106888	Spring, Brake Rod	76	812000001	E-Ring
26	819131316	Washer	77	532123583	Key, Square
27	876020412	Pin Cotter 1/8 x 3/4 CAD.	78	532121748	Washer 25/32 x 1-5/8 x 16 Ga.
28	532145204	Rod, Parking Brake	81	532165596	Shaft Asm Cross Tapered
29	532071673	Cap, Parking Brake	82	532165711	Spring Torsion T/A
30	532169592	Bracket, Transaxle	83	819171216	Washer 17/32 x 3/4 x 16 Ga.
32	874760512	Bolt Hex Hd 5/16-18 Unc x 3/4	84	532169594	Link Transaxle
34	532155071	Shaft, Foot Pedal	89	532166510	Console, Shift
35	532120183	Bearing, Nylon	90	532124346	Nut, Self Thd Wsh Hd 1/4 Zinc
36	819211616	Washer	95	532170201	Control Asm. Bypass Hydro
37	532124963	Pin, Roll	96	532124788	Retainer Spring 1" Zinc/Cad
38	532131494	Pulley, Idler, Flat	116	872110610	Bolt Rdhd Sq Neck 3/8-16 x 1-1/4
39	874760644	Bolt	150	532165850	Bushing Bellcrank Grd Drive
40	532124965	Spacer Split	151	819133210	Washer 13/32 x 2 x 10 Ga.
41	532165838	Keeper, Belt Idler Flat	156	532166002	Washer Srrted 5/16ID x 1.125
42	819131312	Washer 13/32 x 13/16 x 12 Gauge	158	532165589	Bracket Shift Mount
47	532127783	Pulley, Idler, V-Groove	159	532165494	Hub Tapered Flange Shift Lt
48	532154407	Bellcrank Grnd Clutch	161	872140406	Bolt Rdhd Sqnk 1/4-20 x 3/4 Gr.5
49	532123205	Retainer, Belt	162	873680400	Nut Crownlock 1/4-20 Unc
50	874760624	Bolt	163	874780416	Bolt Hex Fin 1/4-20 Unc x 1 Gr 5
51	873680600	Nut	164	819091010	Washer 5/8 x .281 x 10 Ga
52	873680500	Nut Crown Lock 5/16-18	165	532165623	Bracket Pivot Lever
53	532105710	Link, Clutch	166	532166880	Screw 5/16-18 x 5/8
55	532105709	Spring, Return, Clutch	168	532165492	Bolt Shoulxder 5/16-18 x .561
56	874760620	Bolt	169	532165580	Plate Fastening Lt
57	532140294	V-Belt, Ground Drive	197	532169613	Nyliner Snap-In 5/8" ID
59	532169691	Keeper, Center Span	198	532169593	Washer Nyl 7/8 ID x .105" Hyd
61	817060612	Screw 3/8-16 x 3/4	199	532169612	Bolt Shoulder 5/16-18 Unc
62	532123533	Cover, Pedal	200	872140508	Bolt Rhdh Sqnk 5/16-18 Unc x 1
			202	872110612	Bolt Carr Sh 3/8-16 x 1-1/2 Gr. 5

**NOTE:** All component dimensions given in U.S. inches  
1 inch = 25.4 mm

# REPAIR PARTS

TRACTOR - - MODEL NO. YTH150 (HFYTH155G) PRODUCT NO. 954 17 00-24

## STEERING ASSEMBLY

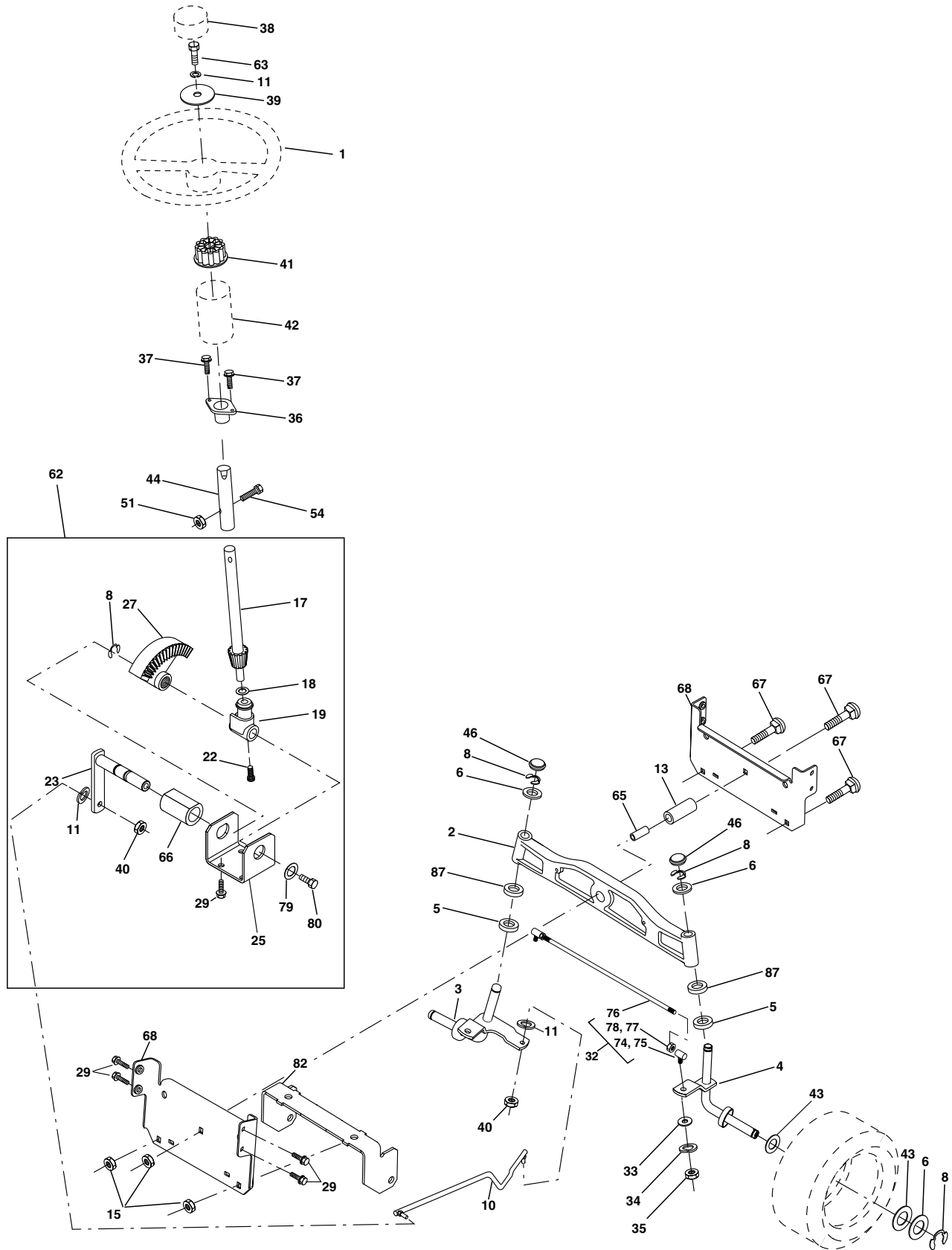



# REPAIR PARTS

TRACTOR - - MODEL NO. YTH150 (HFYTH155G) PRODUCT NO. 954 17 00-24

## STEERING ASSEMBLY

KEY NO.	PART NO.	DESCRIPTION
1	532166627	Wheel Steering
2	<b>532172393</b>	Axle Cast Lt Machined
3	532169840	Spindle Asm LH
4	532169839	Spindle Asm RH
5	532124931	Bearing Race Thrust Harden
6	532121748	Washer 25/32 X 1-5/8 X 16 Ga
8	812000029	Ring Klip #t5304-75
10	532169832	Link Drag
11	810040600	Washer Lock Hvy Hlcl Spr 3/8
13	532136518	Spacer Brg Axle Front
15	532145212	Nut Hex Flange Lock
17	532156546	Shaft Asm Strg
18	532057079	Washer Thrust 515x 750x 033
19	532160395	Support Shaft
22	532165857	Screw Hex WSH HD Torx
23	532165851	Shaft Asm Pittman
25	532154406	Bracket Steering
27	532136874	Gear Sector
29	817060612	Screw 3/8-16x3/4
32	532171888	Rod Tie BJ Solid
33	819111216	Washer 11/32 x 3/4 x 16 Ga.
34	810040500	Washer Lock Hvy Hlcl Spr 5/16
35	873540500	Crownlock Nut 5/16-24 Unf
36	532155099	Bushing Strg
37	532152927	Screw
38	532166626	Insert Cap Strg Wh
39	819132411	Washer 13/32 X 1-1/20 x 11 Ga
40	532124701	Lock nut
41	532159945	Adaptor Wheel Strg
42	532169634	Boot Steering Shaft
43	532121749	Washer 25/32 X 1 1/4 X 16 Ga
44	532153720	Extension Steering Shaft LR/LT
46	532121232	Cap Spindle Fr Top Blk
51	873800500	Nut Lock Hex w/Ins 5/16-18
54	874780520	Bolt Fin Hex 5/16-18 Unc x 1-1/4
62	532167902	Kit, Steering Assembly Svc
63	874780616	Bolt Fin Hex 3/8-16unc x 1 Gr. 5
65	532160367	Spacer Brace Axle
66	532154404	Bearing Arm Pittman
67	872140618	Bolt Rdhd Sq 3/8-16 x 2-1/4
68	532169827	Axle, Brace
74	<b>532109850</b>	Joint Asm Ball Rh
75	<b>532109851</b>	Joint Asm Ball Lh
76	<b>532170257</b>	Rod Tie Link
77	<b>873700600</b>	Nut Hex Jam 3/8-24 Unf Lh
78	<b>873360600</b>	Nut Hex Jam 3/8-24 Unf
79	819132012	Washer 13/32 x 1-1/4 x 12 Ga.
80	874950612	Bolt Hex Nylon 3/8-16 x 3/4
82	532169835	Bracket Susp Chassis Front
87	532173966	Washer Flat .781 x 1-1/2 x .14

**NOTE:** All component dimensions given in U.S. inches.  
1 inch = 25.4 mm.

# REPAIR PARTS

TRACTOR - - MODEL NO. YTH150 (HFYTH155G) PRODUCT NO. 954 17 00-24  
SEAT ASSEMBLY

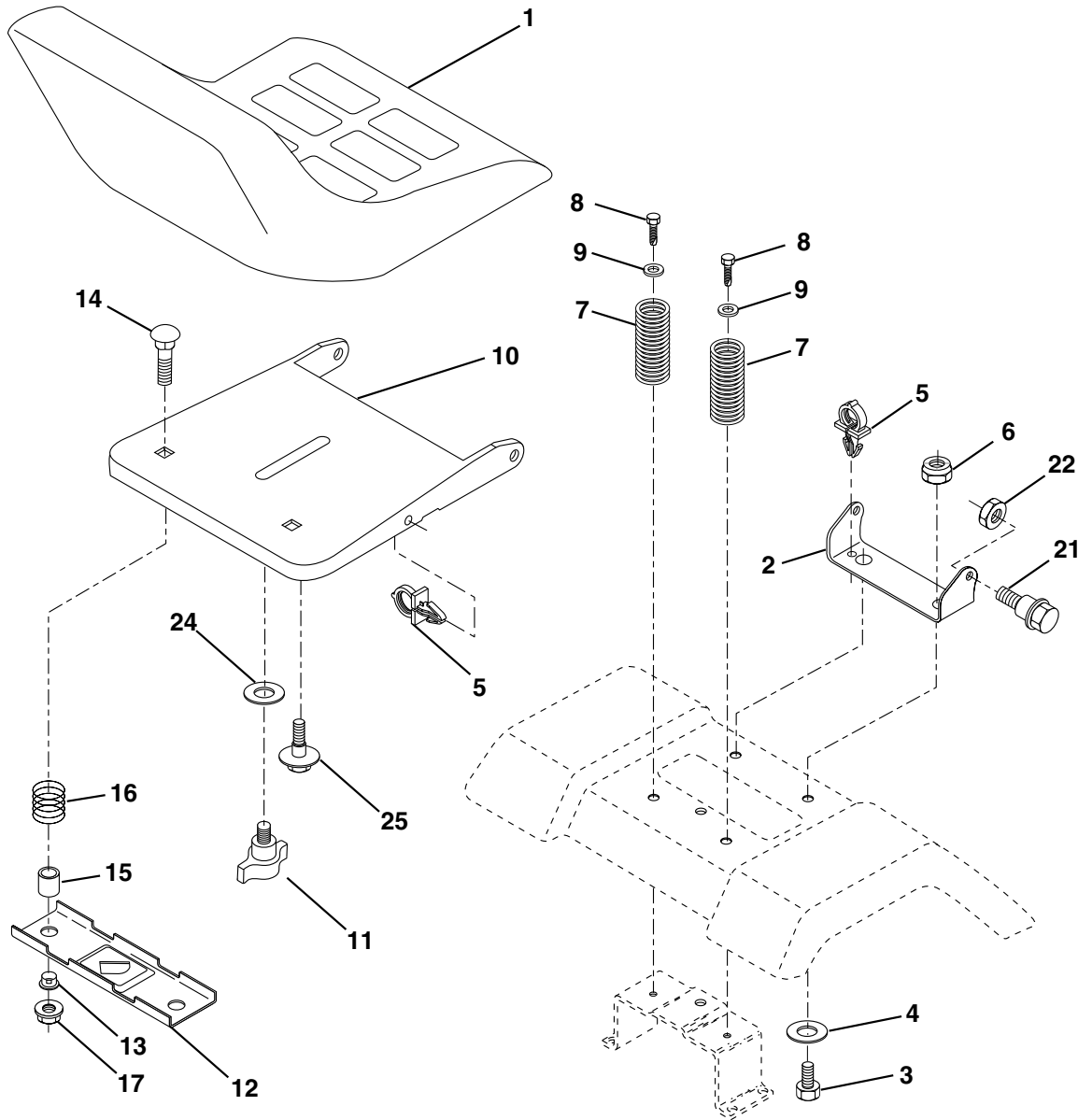

KEY NO.	PART NO.	DESCRIPTION
1	532140839	Seat
2	532140551	Bracket Pivot Seat 8 720
3	871110616	Bolt Fin Hex 3/8-16unc X 1
4	819131610	Washer 13/32 X 1 X 10 Ga
5	532145006	Clip Push-In
6	873800600	Nut Lock 3/8-16 Unc
7	532124181	Spring Seat Cprsn 2 250 Blk Zi
8	817000616	Screw 3/8-16 X 1-1/2
9	819131614	Washer 13/32 X 1 X 14 Ga.
10	<b>532174894</b>	Pan Seat
11	532166369	Knob Seat

KEY NO.	PART NO.	DESCRIPTION
12	532121246	Bracket Mounting Switch
13	532121248	Bushing Snap Blk Nyl 50 Id
14	872050412	Bolt Rdhd Sht Nk 1/4-20x1-1/2
15	532134300	Spacer Split 28x 96 Yel Zinc
16	532121250	Spring Cprsn 1 27 Blk Pnt
17	532123976	Nut Lock 1/4 Lge Flg Gr 5 Zinc
21	532171852	Bolt Shoulder 5/16-18 Unc-2A
22	873800500	Nut Hex Lock W/Ins 5/16-18
24	819171912	Washer 17/32 X 1-3/16 X 12 Ga.
25	532127018	Bolt Shoulder 5/16-18 X 62

**NOTE:** All component dimensions given in U.S. inches.  
1 inch = 25.4 mm

# REPAIR PARTS

TRACTOR - - MODEL NO. YTH150 (HFYTH155G) PRODUCT NO. 954 17 00-24  
DECALS

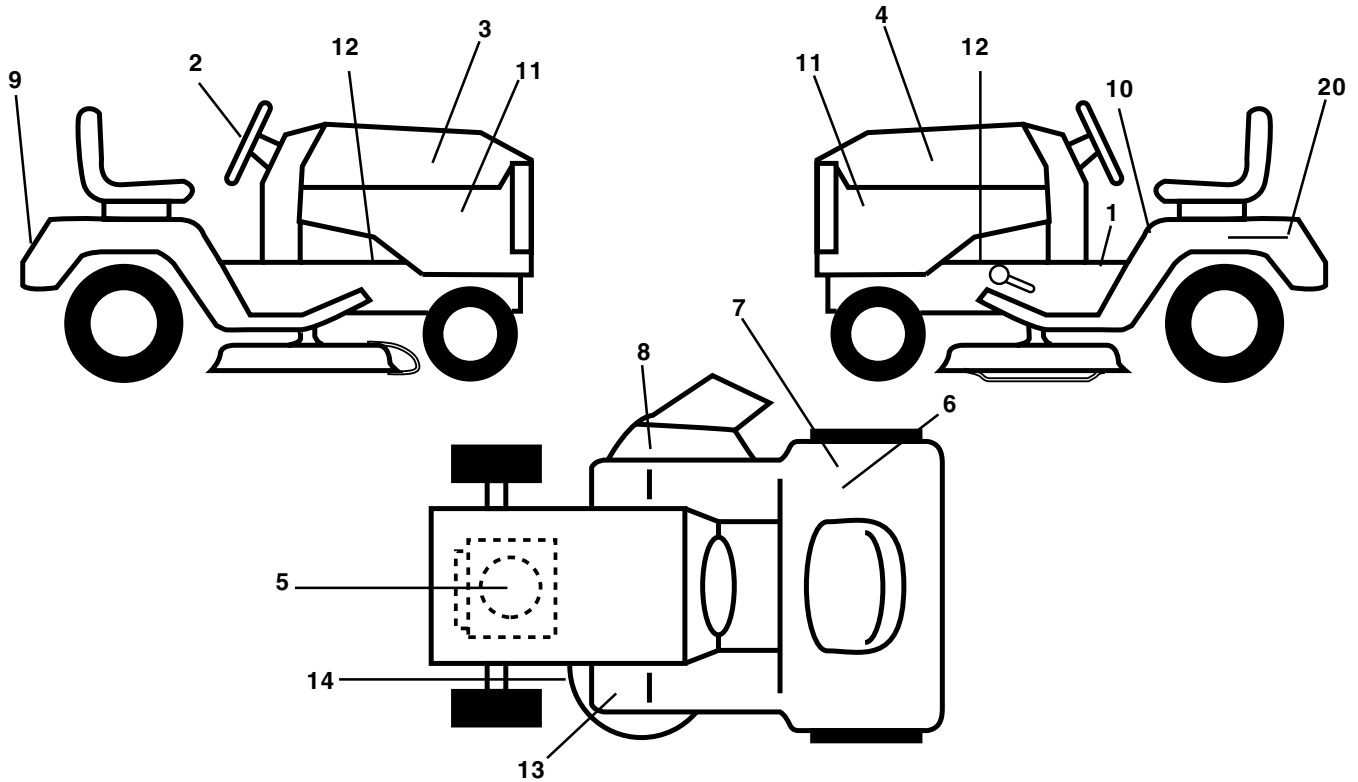

KEY NO.	PART NO.	DESCRIPTION
1	532140837	Decal Saddle Parking
2	532170564	Decal Wheel Steering
3	532150729	Decal Hood RH
4	532150730	Decal Hood LH
5	<b>532176400</b>	Decal HP Engine
6	532126187	Decal 100 DBA
7	532145437	Decal Europe Stand CE
8	532145494	Decal Mower Cut/Finger
9	532150617	Decal Fender Husq
10	532145498	Decal Read Owner's Man Syms
11	532159713	Decal Panel Side B & S Logo

KEY NO.	PART NO.	DESCRIPTION
12	532159736	Decal Chassis Hot Muffler
13	532159737	Decal Brake/Clutch Symbol LT
14	532160396	Decal V-Belt Schematic
20	532145005	Decal Bat Dan/Psn
--	532169210	Decal By Pass Lt Hydro
--	532171284	Pad Footrest LH STLT
--	532171285	Pad Footrest RH STLT
--	532138311	Decal Handle Lft Height Adjust
--	<b>532176144</b>	Manual Operator's (Euro)
--	<b>532176145</b>	Manual Operator's (Scand)
--	532162598	Decal Drawbar Load Limit

Available accessories not included with tractor:

--	MK420	Mulch Kit w/Blades
--	C42	Grass Catcher

## WHEELS & TIRES

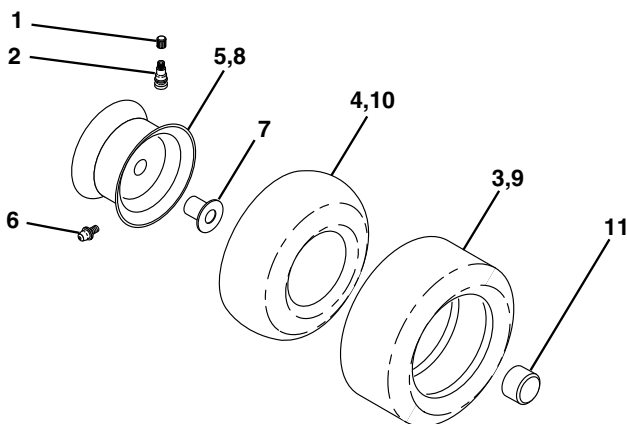

KEY NO.	PART NO.	DESCRIPTION
1	532059192	Cap Valve Tire
2	532065139	Stem Valve
3	532106222	Tire F Ts 15 X 60 - 6 Service
4	532059904	Tube Front (Service Item Only)
5	532138336	Rim Asm 6"front
6	532124957	Fitting Grease (Front Wheel Only)
7	532124959	Bearing Flange (Front Wheel Only)
8	532138337	Rim Asm 8"rear
9	532122082	Tire R Ts 20 x 10-8 C Service
10	532124926	Tube Rear (Service Item Only)
11	<b>532175039</b>	Cap Axle Blk 1 50 X 1 00
--	532144334	Sealant, Tire (10 oz. Tube)

**NOTE:** All component dimensions given in U.S. inches  
1 inch = 25.4 mm

# REPAIR PARTS

TRACTOR - - MODEL NO. YTH150 (HFYTH155G) PRODUCT NO. 954 17 00-24  
ENGINE

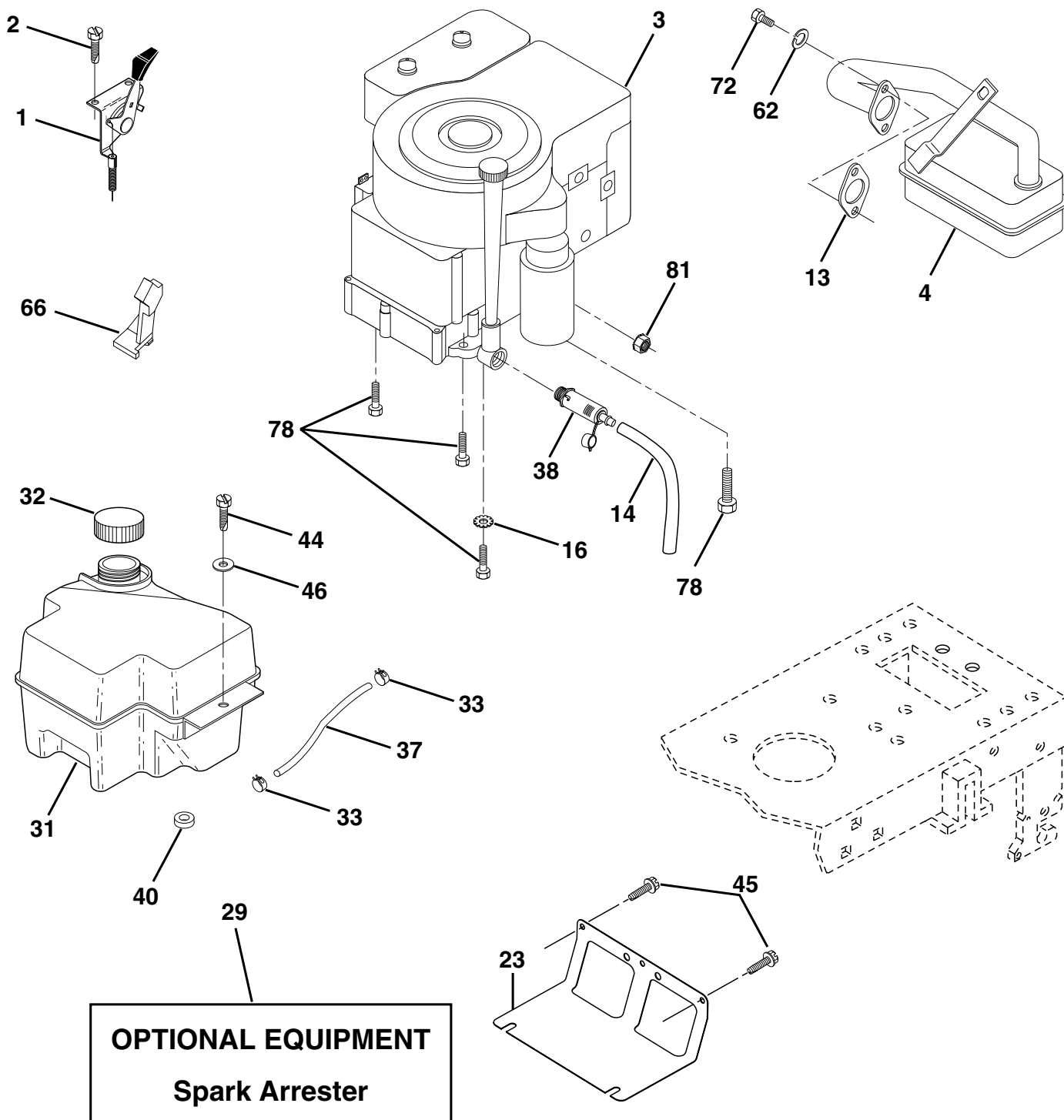

# REPAIR PARTS

TRACTOR - - MODEL NO. YTH150 (HFYTH155G) PRODUCT NO. 954 17 00-24  
ENGINE

KEY NO.	PART NO.	DESCRIPTION
1	<b>532170865</b>	Control Th/ch Flag
2	817720410	Screw Hex Thd Cut 1/4-20x5/8 T
3	-----	Engine, Briggs Model 311777 (Order parts from engine manufacturer)
4	532137352	Muffler LT B&S 15 HP IC OHV
13	532165291	Gasket
14	<b>532148456</b>	Tube Drain Easy
16	811050600	Washer Lock Ext Tooth 3/8
23	532169837	Shield Browning/Debris Guard
29	532137180	Kit Spark Arrestor (Flat Scrn)
31	<b>532174642</b>	Tank Fuel Front 2 00
32	532140527	Cap Asm Fuel W/sym Vented
33	532123487	Clamp Hose Black
37	532137040	Line Fuel 20"
38	<b>532148315</b>	Plug Drain Oil Easy
40	532124028	Bushing Snap Nyl Blk Fuel Line
44	817670412	Screw Hexwsh Thdrol 1/4-20x3/4
45	817000612	Screw Hex Wsh Thdrol
46	819091416	Washer 9/32 X 7/8 X 16 Ga
62	810040500	Washer Lock Hvy Hlcl Spr 5/16
66	532127951	Stop Throttle
72	871070512	Screw Hexhd Cap 5/16-18x 3/4
78	817060620	Screw 3/8-16x1-1/4
81	873510400	Nut Keps Hex 1/4-20 Unc

**NOTE:** All component dimensions given in U.S. inches  
1 inch = 25.4 mm

# REPAIR PARTS

TRACTOR - - MODEL NO. YTH150 (HFYTH155G) PRODUCT NO. 954 17 00-24  
MOWER DECK

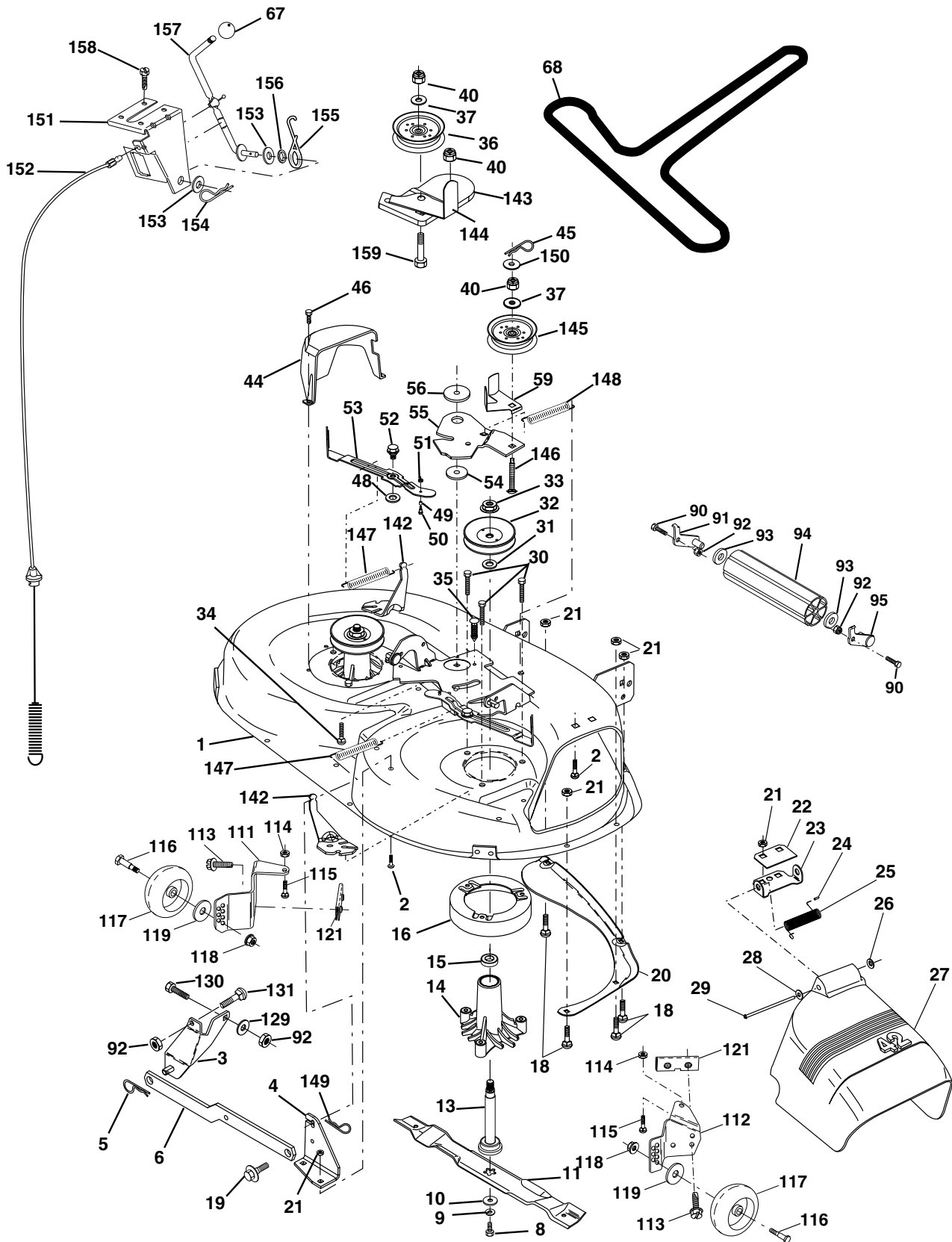

# REPAIR PARTS

TRACTOR - - MODEL NO. YTH150 (HFYTH155G) PRODUCT NO. 954 17 00-24

## MOWER DECK

KEY NO.	PART NO.	DESCRIPTION	KEY NO.	PART NO.	DESCRIPTION
1	532165892	Deck Asm MWR 42"weldment	68	532144959	V-Belt Mower 42"
2	872140506	Bolt Rdhd Sqnk 5/16-18unc X3/4	90	874760616	Bolt Fin Hex 3/8-16 UNC x 1
3	532138017	Bracket Asm Fr Sway Bar 38/42	91	532132274	Bracket Asm Noseroller LH
4	532165460	Bracket Asm Deck 42"sway Bar	92	873800600	Nut Lock Hex W/Ins 3/8-16 Unc
5	532124670	Retainer Spring	93	819171416	Washer 17/32 x 7/8 x 16 Ga.
6	532130832	Arm Suspension Rear	94	532132264	Roller Nose 38 & 42
8	532850857	Bolt 3/8 - 24 X 1.25 Gr 8	95	532132273	Bracket Asm Noseroller RH
9	810030600	Washer Lock Hvy 3/8	111	532155197	Bracket Wheel Gauge LH 42" Deck
10	532140296	Washer Hard Blade Mower Vented	112	532155198	Bracket Gauge Wheel RH 42" Deck
11	532138498	Blade Mower	113	<b>817060514</b>	Screw Tapping 5/16-18 Unc
13	532137645	Shaft Asm W/lower Bearing	114	873510500	Nut Keps 5/16-18 UNC
14	532128774	Housing Mandrel Vented	115	872110504	Bolt Carriage 5/16-UNC x 1/2
15	532110485	Bearing Ball Mandrel	116	532124842	Bolt Shoulder
16	532140329	Stripper Mower Vented	117	532165746	Wheel Gauge Blk
18	872140505	Bolt Rdhd Sqnk 5/16-18 X 5/8	118	873930600	Nut Centerlock 3/8-16 UNC
19	532132827	Bolt Shoulder	119	819121414	Washer 3/8 x 7/8 x 14 Ga.
20	532159770	Baffle Vortex 42	121	532143723	Bracket Extruded Gauge Wheel
21	873680500	Nut Crownlock 5/16-18 UNC	129	819131312	Washer 13/32 x 13/16 x 12 Ga.
22	532134753	Stiffener Bracket 42"deck	130	874780616	Bolt Fin Hex 3/8-16 UNC x 1 Gr. 5
23	532131267	Bracket Deflector Mower 42"	131	872140608	Bolt Rdhd Sqnk 3/8-16 x 1
24	532105304	Cap Sleeve 80x 112 Blk Mower	142	532165890	Arm Spring Brake Mower
25	532123713	Spring Torsion Deflector 2 52	143	532157109	Bracket Arm Idler 42"
26	532110452	Nut Push Phos & Oil	144	532158634	Keeper Belt 42" Clutch Cable
27	532171859	Shield Deflector Mower 42" Blk	145	532165888	Pulley Idler Flat
28	819111016	Washer 11/32 X 5/8 X 16 Ga	146	<b>532171977</b>	Bolt Carriage Idler
29	532131491	Rod Hinge 42"6 75 Wlg	147	532131335	Spring Extension
30	532157722	Screw Thdrol Washer Head	148	532169022	Spring Return Idler
31	532129963	Washer Spacer Mower Vented	149	532165898	Retainer Spring Yellow
32	532153535	Pulley Mandrel 42/44/50	150	819091216	Washer 9/32 x 3/4 x 16 Ga.
33	532137266	Nut 9/16 Toplock Flng Oil Dip	151	532169670	Bracket Clutch Cable
34	872110614	Bolt Rdhd 3/8-16uncx1-3/4 Gr5	152	532169676	Clutch Cable 42"
35	532133835	Fastner Christmas Tree	153	532169674	Washer Flat 3/8" Type B
36	532131494	Pulley Idler Flat 3 060	154	532169675	Spring Retainer
37	819131316	Washer 13/32 X 13/16 X 16	155	532169671	Spring Retention Lvr Clutch Cable
40	873680600	Nut Crownlock 3/8-16 UNC	156	532169672	Spacer Clutch Cable
44	532140088	Guard Mandrel LH Black	157	532169669	Rod Clutch Cable
45	532124788	Spring Retainer 1" Zinc/cad	158	817720410	Screw Hex Thd Cut 1/4-20 x 5/8
46	532137729	Screw Hex Thd Cut 1/4-20x5/8 T	159	872140614	Bolt Rdhd Sqn 3/8-16 Unc x 1-3/4
48	532133944	Washer Hardened Smaller	--	532130794	Mandrel Asm Service (Includes Key Nos. 8-10, 12-15, 31 and 33)
49	<b>532174284</b>	Roller Asm Cam Follower 42"dec	--	532171491	Deck Serv 42"mch S Bar Mult-Lang (Standard Deck - Order noseroller, mulch cover and gauge wheel components separately Key Nos. 90-95, 101-106 and 111-120)
50	532131340	Bolt Shldr 10-24 Zinc Gr 5 42"			
51	532069180	Nut Lock #10-24 Unc			
52	532139888	Bolt Shoulder 5/16-18 Unc Blkz			
53	532131845	Arm Asm Pad Brake			
54	532133943	Washer Hardened			
55	532155046	Arm Idler 42"mower LT/YT			
56	532165723	Spacer Retainer Mower			
59	532141043	Guard TUV Idler			
67	532106932	Knob Rd 3/8-16 Plstc Thd Blk			

**NOTE:** All component dimensions given in U.S. inches  
1 inch = 25.4 mm

# REPAIR PARTS

TRACTOR - - MODEL NO. YTH150 (HFYTH155G) PRODUCT NO. 954 17 00-24  
MOWER LIFT

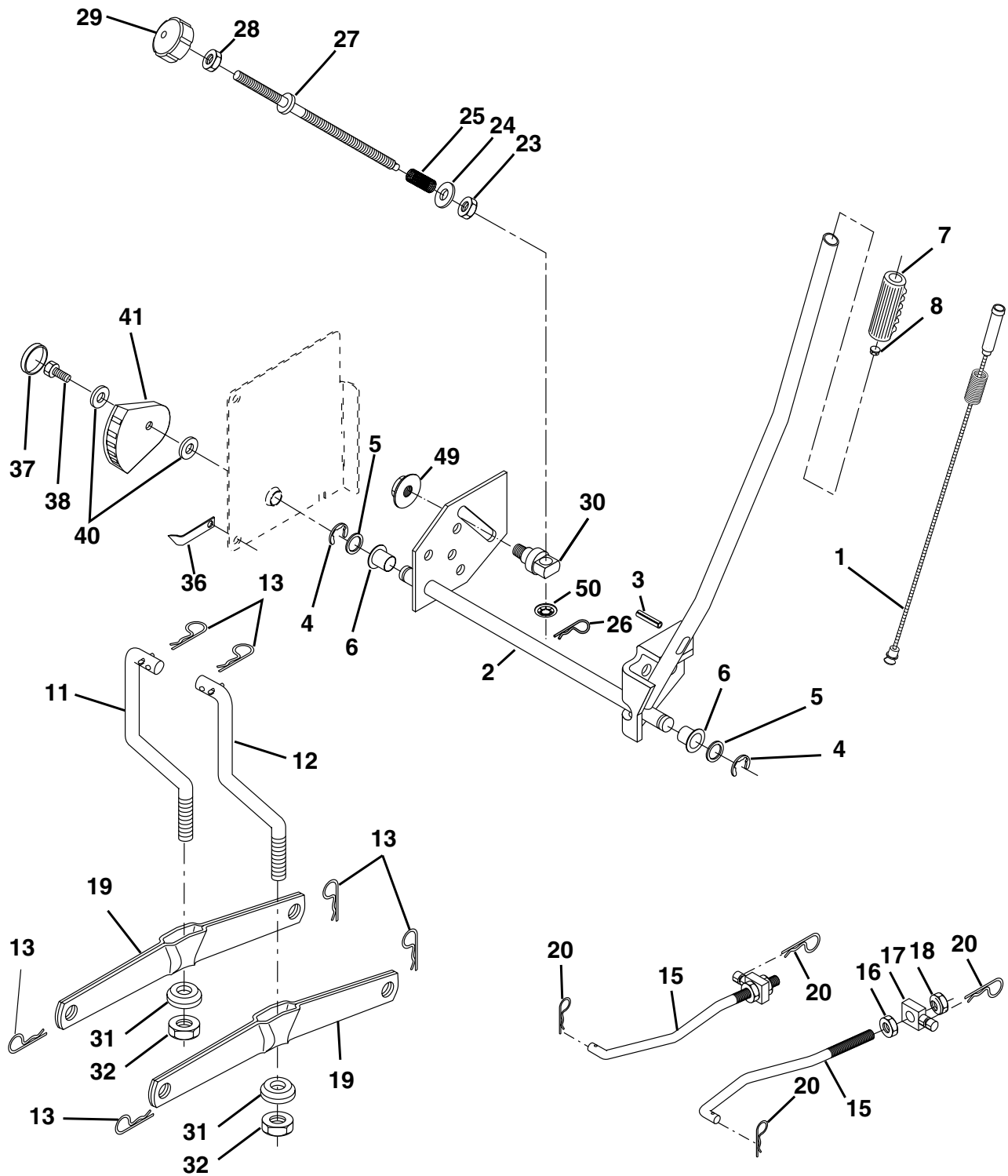



# REPAIR PARTS

TRACTOR - - MODEL NO. YTH150 (HFYTH155G) PRODUCT NO. 954 17 00-24  
MOWER LIFT

KEY NO.	PART NO.	DESCRIPTION
1	532159460	Wire Asm Inner W/plunger 17 32
2	532159471	Shaft Asm Lift LH Inf Hgt P/L
3	532105767	Pin Groove 1 500 Zinc
4	812000002	E Ring #5133-62
5	819211621	Washer 21/32 X 1 X 21 Ga
6	532120183	Bearing Nylon Blk 629 Id
7	532125631	Grip Handle
8	532124526	Button Plunger Black
11	532139865	Link Lift LH
12	532139866	Link Lift RH
13	532124670	Retainer Spring
15	532173288	Link Front
16	873350800	Nut Jam Hex 1/2-13 Unc
17	532130171	Trunnion Blk Zinc
18	873800800	Nut Lock W/wsh 1/2-13unc
19	532139868	Arm Suspension Rear
20	532163552	Retainer Spring
23	532110807	Nut Special
24	819131016	Washer 13/32 X 5/8 X 16 Ga
25	532124874	Spring 2-1/8"
26	532169484	Retainer Clip
27	532126971	Rod Adj Lift Zinc 7 49 Wrk Lg
28	873350600	Nut Hex Jam 3/8-16 Unc
29	532138057	Knob Inf 3/8-16 Unc Blk W/sym
30	532150233	Trunnion Inf Height
31	532169865	Bearing pvt. Lift
32	873540600	Nut Crownlock 3/8-24
36	532155097	Pointer pnt Height Ind.
37	532123935	Plug hole Blk 1.485/1.515 Dia
38	817060516	Screw 5/16-18 x 1
40	819112410	Washer 11/32 x 1-1/2 10 Ga
41	532155098	Indicator Height
49	532145212	Nut Hex Flange Lock
50	532110452	Push Nut

**NOTE:** All component dimensions given in U.S. inches  
1 inch = 25.4 mm

# TRACTOR - - MODEL NO. YTH150 (HFYTH155G) PRODUCT NO. 954 17 00-24 SCHEMATIC

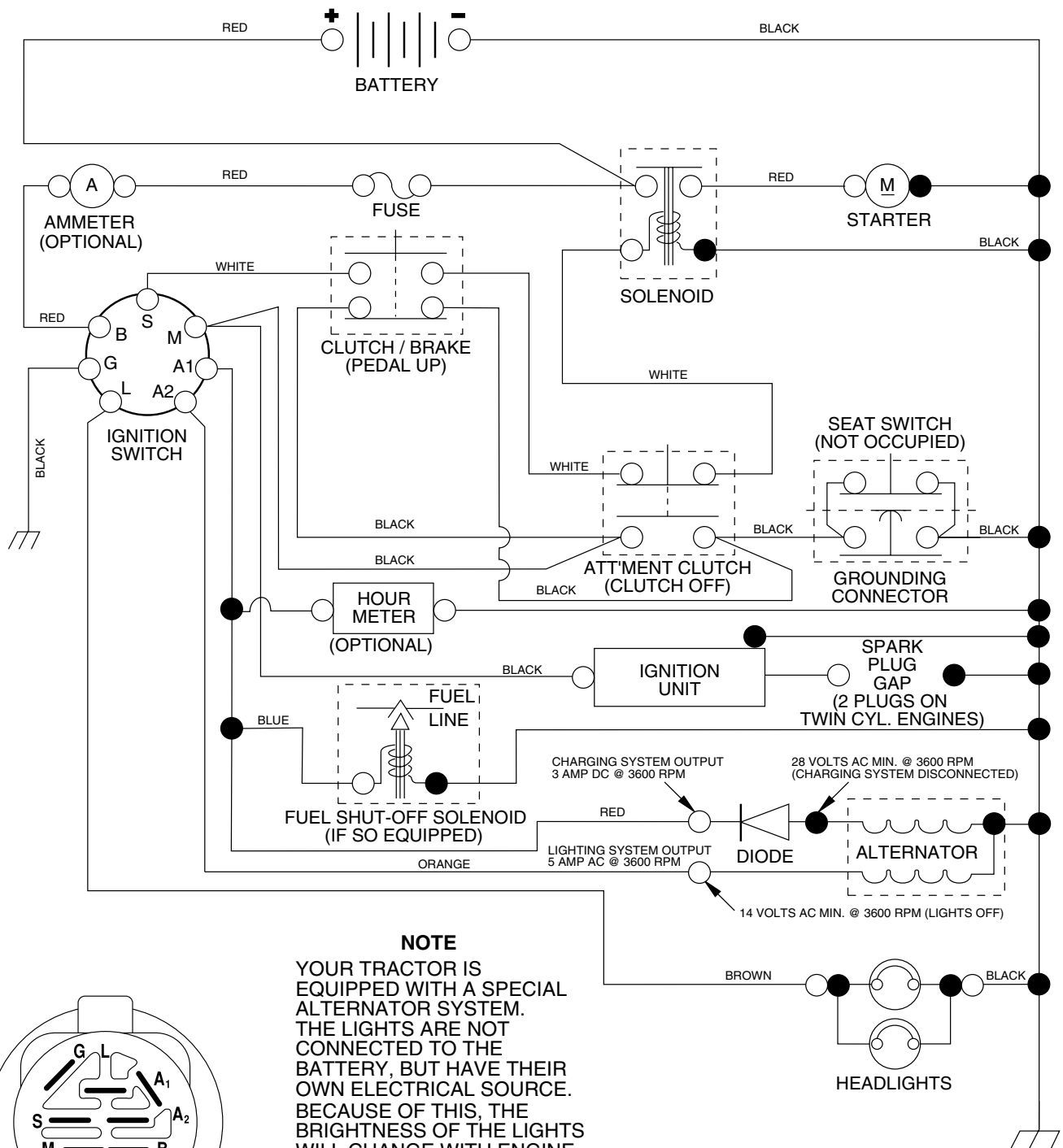

## NOTE

YOUR TRACTOR IS EQUIPPED WITH A SPECIAL ALTERNATOR SYSTEM. THE LIGHTS ARE NOT CONNECTED TO THE BATTERY, BUT HAVE THEIR OWN ELECTRICAL SOURCE. BECAUSE OF THIS, THE BRIGHTNESS OF THE LIGHTS WILL CHANGE WITH ENGINE SPEED. AT IDLE THE LIGHTS WILL DIM. AS THE ENGINE IS SPEEDED UP, THE LIGHTS WILL BECOME THEIR BRIGHTEST.

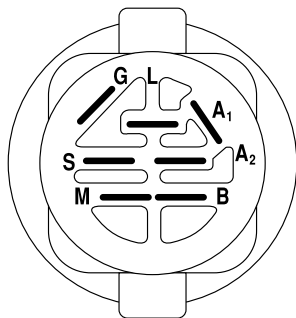

## IGNITION SWITCH

POSITION	CIRCUIT	"MAKE"
OFF	M+G+A1	NONE
RUN/LIGHT	B+A1	A2+L
RUN	B+A1	NONE
START	B + S + A1	NONE

## WIRING INSULATED CLIPS

**NOTE:** IF WIRING INSULATED CLIPS WERE REMOVED FOR SERVICING OF UNIT, THEY SHOULD BE REPLACED TO PROPERLY SECURE YOUR WIRING.

NON-REMOVABLE CONNECTIONS

REMOVABLE CONNECTIONS