

YT150

Spare parts
Ersatzteile
Pièces détachées
Reserve onderdelen
Repuestos
Reservdelar

REPAIR PARTS

TRACTOR - - MODEL NO. YT150 (HEYT155H) PRODUCT NO. 954 17 00-37
ELECTRICAL

KEY NO.	PART NO.	DESCRIPTION
1	532144925	Battery
2	874760412	Bolt Hex Hd 1/4-20unc X 3/4
8	532156417	Case Battery w/2 Holes
16	532153664	Switch Interlock Push-In
21	532166181	Harness Asm Light W/4152j
22	532004152	Bulb Light #1 156
24	532124780	Cable Battery 6 Ga 11" red
25	532146147	Cable Battery 6 Ga 44" red w/16 wire
26	532175158	Fuse 20 AMP
27	873510400	Nut Keps Hex 1/4-20 Unc
28	532124773	Cable Ground 6 Ga 12" black
29	532121305	Switch Plunger Nc Gray
30	532175566	Switch Ign
33	532140401	Key Ign Molded Generic
40	532170217	Harness ign
41	871110408	Bolt Blk Fin Hex 1/4 - 20 x 1/2
42	532131563	Cover Terminal Red
43	532175141	Solenoid
48	532140844	Adapter Ammeter Rectangular
52	532141940	Protection Wire Loop

NOTE: All component dimensions given in U.S. inches.
1 inch = 25.4 mm.

REPAIR PARTS

TRACTOR - - MODEL NO. YT150 (HEYT155H) PRODUCT NO. 954 17 00-37
CHASSIS AND ENCLOSURES

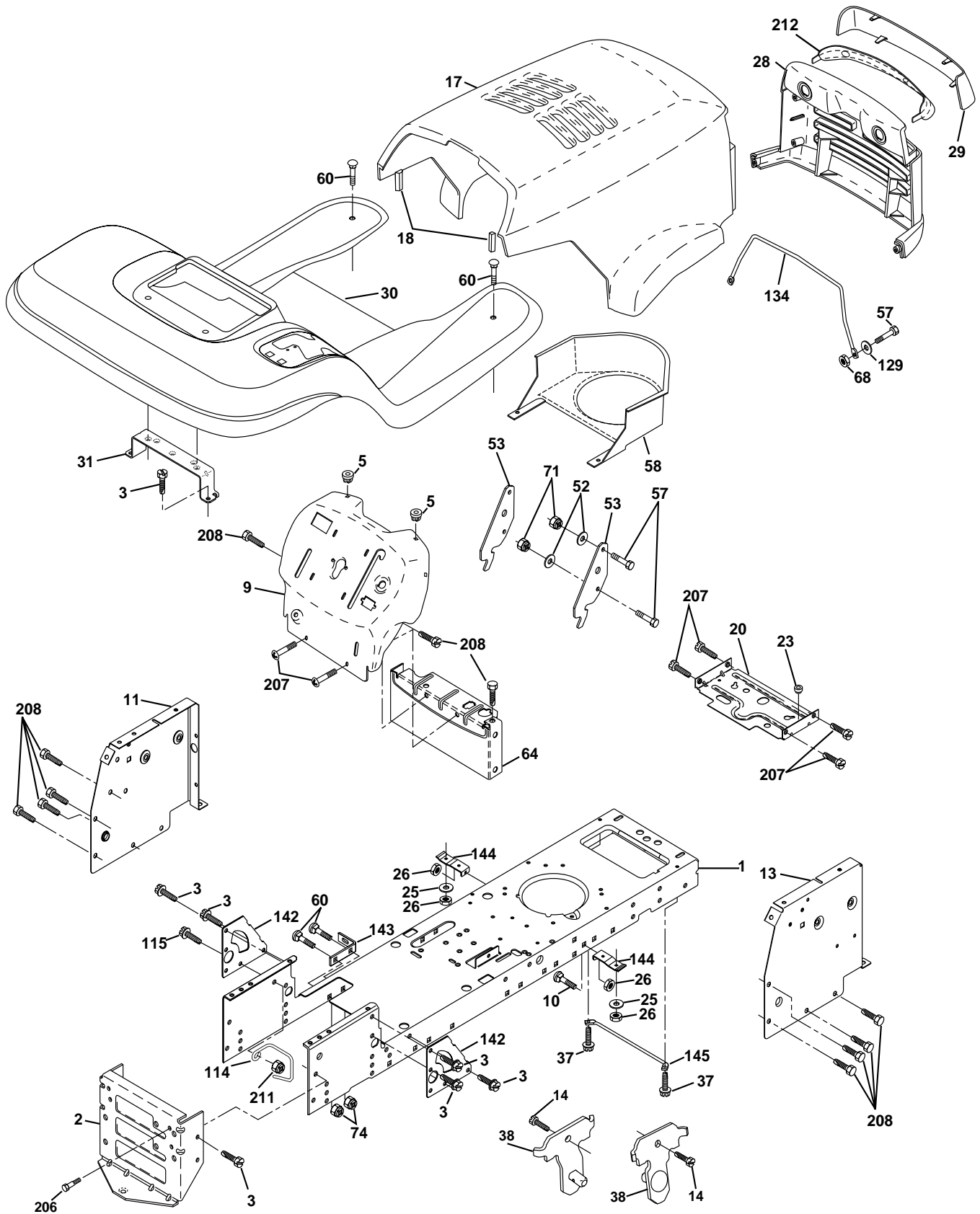

REPAIR PARTS

TRACTOR - - MODEL NO. YT150 (HEYT155H) PRODUCT NO. 954 17 00-37 CHASSIS AND ENCLOSURES

KEY NO.	PART NO.	DESCRIPTION
1	532174619	Chassis Stamping
2	532176554	Drawbar
3	817060612	Screw 3/8-16x3/4
5	532155272	Bumper Hood/Dash
9	532171853	Dash P/L
10	872140608	Bolt Carriage 3/8-16 x 1
11	532155927	Panel Dash Lh
13	532172108	Panel Dash Rh
14	817490608	Screw Thdrol 3/8-16 x 1/2
17	532165378	Hood LT/PL Husqvarna
18	532126938	Bumper Hood
20	532156437	Plate Mtg Battery Fuel Tank Fr
23	532124028	Bushing
25	819131312	Washer 13/32 X 13/16 X 12 Ga
26	873800600	Nut Lock Hex W/Ins 3/8-16 UNC
28	532165379	Grille LT/PL Husqvarna
29	532165380	Lens LT/PL Husqvarna
30	532171854	Fender Footrest STLT Pnt
31	532139976	Bracket Support Fender
37	817490508	Screw Thdrol 6/16-18 x 1/2 TYT
38	532175710	Bracket, Asm. Pivot, Mower Rear
52	819091416	Washer 9/32 x 7/8 x 16 Ga.
53	532150067	Bracket Pnt. Pick off LT/PL Husqvarna
57	874780412	Bolt Hex 1/4-20 x 3/4
58	532150127	Air Duct Engine P/L
60	872140606	Bolt Rdhd Sqnk 3/8-16UNC x 3/4
64	532154798	Dash Lower STLT
68	873510400	Nut Keps Hex 1/4-20 UNC
71	873680400	Nut Crownlock 1/4-20 UNC
74	873680600	Nut Crownlock 3/8-16 UNC
114	532158112	keeper Belt Rear Lh STL
115	817060620	Screw 3/8-16 x 1-1/4
129	819091016	Washer 9/32 x 5/8 x 16 Ga.
134	532160219	Rod Support Hood LT/PL Husq.
142	532165867	Plate Reinforcement STLT
143	532154966	Bracket Swaybar Chassis
144	532154207	Bracket Pnt Footrest STLT
145	532156524	Rod Pivot Chassis/Hood
206	532170165	Bolt Shoulder 5/16-18 TT
207	817670508	Screw Thdrol 5/16-18 x 1/2
208	817670608	Screw Thdrol 3/8-16 x 1/2
211	532145212	Nut Hexflange Lock
212	532156195	Insert Lens Reflective
--	532005479	Plug Button

NOTE: All component dimensions given in U.S. inches.
1 inch = 25.4 mm

REPAIR PARTS

TRACTOR - - MODEL NO. YT150 (HEYT155H) PRODUCT NO. 954 17 00-37
DRIVE

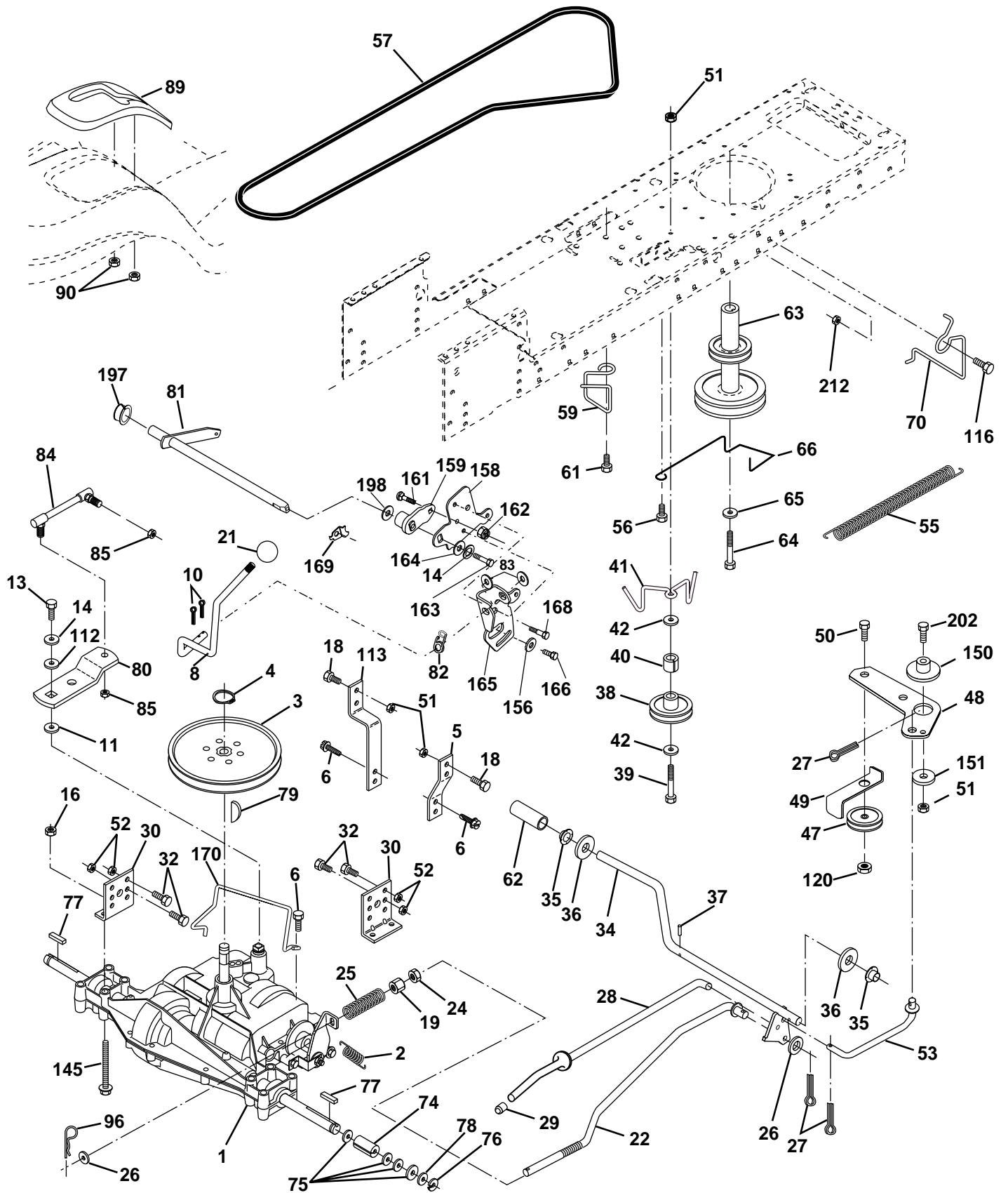

REPAIR PARTS

TRACTOR - - MODEL NO. YT150 (HEYT155H) PRODUCT NO. 954 17 00-37
DRIVE

KEY NO.	PART NO.	DESCRIPTION	KEY NO.	PART NO.	DESCRIPTION
1	-----	Transaxle Peerless 206-545C (Order parts from transaxle manufacturer)	61	817060612	Screw 3/8-16x3/4
2	532146682	Spring Return Brake T/a Zinc	62	532123533	Cover Pedal
3	532123666	Pulley Transaxle 18"tires	63	532175410	Engine Pulley
4	812000028	Ring Retainer #5100-62	64	871170764	Bolt Hex 7/16-20 x 4
5	532121520	Strap Torque 30 Degrees	65	810040700	Washer Lock Hvy Hlcl Spr 7/16
6	817060512	Screw 5/16-18 X 3/4	66	532154778	Keeper Belt Engine F-Proof
8	532165866	Rod Shifter	70	532134683	Guide Belt Mower Drive RH
10	876020416	Pin Cotter 1/8 X 1 Cad	74	532137057	Spacer Axle
11	532105701	Washer Plate Shf 388 Sq Hole	75	532121749	Washer 25/32 X 1 1/4 X 16 Ga
13	874550412	Bolt 1/4-28 Unf Gr 8 W/Patch	76	812000001	E-ring #5133-75
14	810040400	Washer Lock Hvy Helical 1/4	77	532123583	Key Square 2 0 X 1845/ 1865
16	873800500	Nut Lock Hx w/Ins 5/16-18 UNC PL	78	532121748	Washer 25/32 X 1-5/8 X 16 Ga
18	874780616	Bolt Fin Hex 3/8-16 UNC x `1 Gr. 5	79	532125096	Key Woodruff
19	873800600	Nut Lock 3/8-16 Unc	80	532145090	Arm Shift Transaxle
21	532121274	Knob Duckhead1/2-13 Plstc Thd. Blk	81	532165592	Shaft Asm Cross
22	532130804	Rod Brake Blk Zinc 26 840	82	532165711	Spring Torsion T/a
24	873350600	Nut Hex Jam 3/8-16 Unc	83	819171216	Washer 17/32 X 3/4 X 16 Ga
25	532106888	Spring Rod Brake 2 00 Zinc	84	532166231	Link Transaxle
26	819131316	Washer 13/32 X 13/16 X 16 Ga	85	532150360	Nut Nylock 1/4 - 28
27	876020412	Pin Cotter 1/8 X 3/4 Cad	89	532166561	Console Shift 6sp
28	532175765	Rod Brake Parking LT/YT	90	532124346	Nut Self-thd Wsh-hd 1/4 Zinc
29	532071673	Cap Brake Parking	96	532124788	Retainer Spring 1" Zinc/Cad
30	532169592	Bracket Mtg Transaxle	112	819091210	Washer 9/32 x 3/4 x 10 Ga.
32	874760512	Bolt Hex Hd 5/16-18unc X 3/4	113	532127285	Strap Torque Lt
34	532175578	Shaft Asm Pedal Foot	116	872110608	Bolt Rd Sq Neck 3/8-16 x 1
35	532120183	Bearing Nylon Blk 629 Id	120	73900600	Nut Lock Flg 3/8-16
36	819211616	Washer 21/32 X 1 X 16 Ga	145	874490540	Bolt Hex 5/16-18FLGHD
37	532124963	Pin Roll 3/16 X 1"	150	532175456	Spacer Retainer
38	532165936	Pulley Idler Flat	151	819133210	Washer 13/32 x 2 x 10 Ga.
39	874760648	Bolt Fin Hex 3/8-16 Unc x 3	156	532166002	Washer Srrted 5/16 ID x 1 .125
40	532175461	Spacer Split	158	532165589	Bracket Shift Mount
41	532175556	Keeper Belt Idler	159	532165494	Hub Tapered Flange Shift LT
42	819131312	Washer 13/32 X 13/16 X 12 Ga	161	872140406	Bolt Rdhd Sqnk 1/4-20 x 3/4 Gr 5
47	532127783	Pulley Idler V Groove Plastic	162	873680400	Nut Crownlock 1/4-20 Unc
48	532154407	Bellcrank Clutch Grnd Drw STL	163	874780416	Bolt Hex Fin 1/4-20 Unc x 1 Gr. 5
49	532123205	Retainer Belt Style Spring	164	819091010	Washer 5/8 x .281 x 10 Ga.
50	874760624	Bolt Hex Hd 3/8-16unc X 1-1/2	165	532165623	Bracket Pivot Lever
51	873680600	Nut Crownlock 3/8-16 Unc	166	532166880	Screw 5/16-18 x 5/8
52	873680500	Nut Crownlock 5/16-18 Unc	168	532165492	Bolt Shoulder 5/16-18 x .561
53	532105710	Link Clutch 7 66	169	532165580	Plate Fastening LT
55	532105709	Spring Return Clutch 6 75	170	532173898	Keeper Belt Transaxle
56	817060616	Screw 3/8-16 x 1	197	532169613	Nyliner Snap-In 5/8" ID
57	532130801	V-Belt Ground Drive 95 25 42"	198	532169593	Washer Nyl 7/8 ID x .105" Hyd Crd
59	532169691	Keeper Belt Span Ctr	202	872110614	Bolt Carr Sh 3/8-16 x 1-3/4 Gr. 5
			204	817060512	Screw 5/16-18 x 3/4
			212	532145212	Nut Hex Flange Lock

NOTE: All component dimensions given in U.S. inches
1 inch = 25.4 mm

REPAIR PARTS

TRACTOR - - MODEL NO. YT150 (HEYT155H) PRODUCT NO. 954 17 00-37
STEERING ASSEMBLY

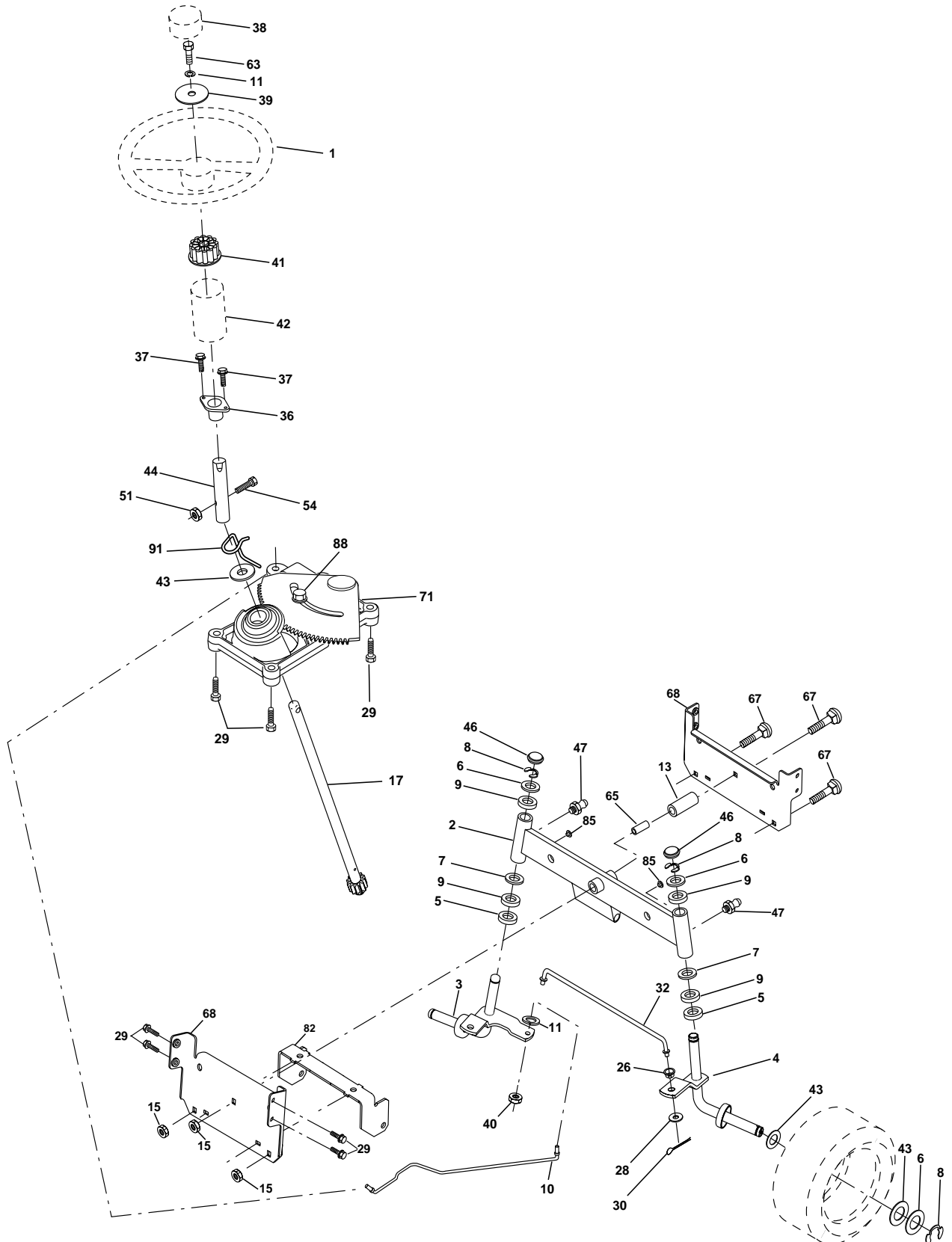

REPAIR PARTS

TRACTOR - - MODEL NO. YT150 (HEYT155H) PRODUCT NO. 954 17 00-37
STEERING ASSEMBLY

KEY NO.	PART NO.	DESCRIPTION
1	532166627	Wheel Steering
2	532154427	Axle Asm STMP Dropped STL
3	532169840	Spindle Asm LH
4	532169839	Spindle Asm RH
5	532124931	Bearing Race Thrust Harden
6	532121748	Washer 25/32 X 1-5/8 X 16 Ga
7	819272016	Washer 27/32 X 1-1/4 X 16 Ga
8	812000029	Ring Klip #t5304-75
9	532124937	Bearing Col Strg Blk
10	532175121	Link Drag
11	810040600	Washer Lock Hvy Hlcl Spr 3/8
13	532136518	Spacer Brg Axle Front
15	532145212	Nut Hex Flange Lock
17	532177876	Shaft Asm Strg
26	532126847	Bushing Link Drag Blk LR
28	819131416	Washer 13/32 X 7/8 X 16 Ga
29	817060612	Screw 3/8-16x3/4
30	876020412	Pin Cotter 1/8 X 3/4 Cad
32	532130465	Rod Tie Wire Form 19 75 Mech
36	532155099	Bushing Strg
37	532152927	Screw
38	532166626	Insert Cap Strg
39	819132411	Washer 13/32 X 1-1/2 x 11
40	532124701	Lock nut
41	532159945	Adaptor Wheel Strg
42	532169634	Boot Steering Shaft
43	532121749	Washer 25/32 X 1 1/4 X 16 Ga
44	532153720	Extension Steering Shaft LR/LT
46	532121232	Cap Spindle Fr Top Blk
47	532124836	Fitting Grease
51	873800500	Nut Lock Hex w/Ins 5/16-18
54	874780520	Bolt Fin Hex 5/16-18 Unc x 1-1/4
63	874780616	Bolt Fin Hex 3/8-16unc x 1 Gr. 5
65	532160367	Spacer Brace Axle
67	872140618	Bolt Rdhd Sqnk 3/8-16 x 2-1/4
68	532169827	Axle, Brace
71	532175146	Steering Asm.
82	532169835	Bracket Susp Chassis Front
85	532133835	Fastener Christmas Tree
88	532175118	Bolt Shoulder 7/16-20 Unc
91	532175553	Clip Steering

NOTE: All component dimensions given in U.S. inches.
1 inch = 25.4 mm.

REPAIR PARTS

TRACTOR - - MODEL NO. YT150 (HEYT155H) PRODUCT NO. 954 17 00-37 SEAT ASSEMBLY

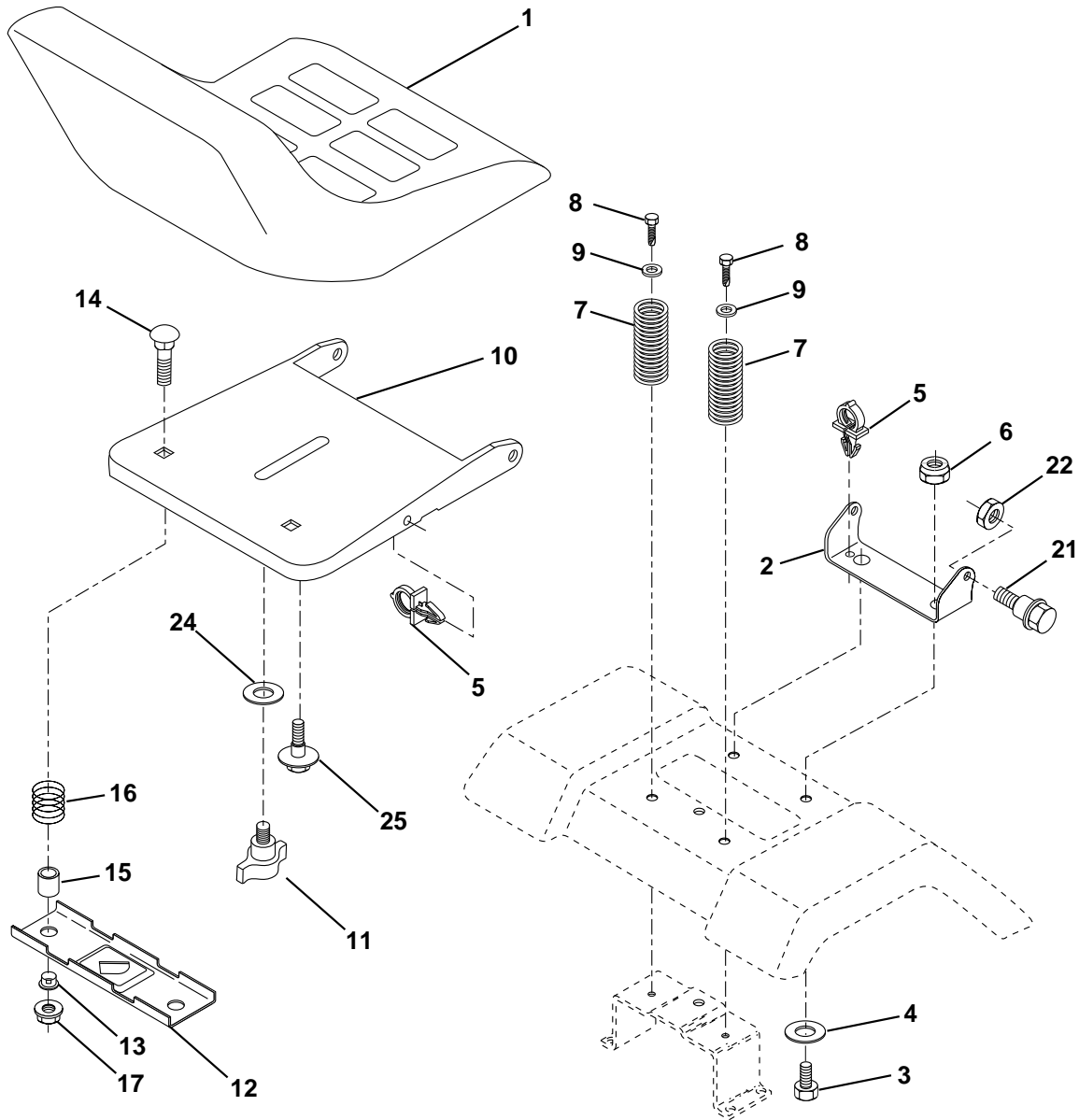

KEY NO.	PART NO.	DESCRIPTION
1	532140839	Seat
2	532140551	Bracket Pivot Seat 8 720
3	871110616	Bolt Fin Hex 3/8-16UNC x 1
4	819131610	Washer 13/32 x 1 x 10 Ga
5	532145006	Clip Push-In
6	873800600	Nut Lock 3/8-16 Unc
7	532124181	Spring Seat Cprsn 2 250 Blk Zi
8	817000616	Screw 3/8-16 x 1-1/2
9	819131614	Washer 13/32 x 1 x 14 Ga.
10	532174894	Pan Seat
11	532166369	Knob Seat

KEY NO.	PART NO.	DESCRIPTION
12	532121246	Bracket Mounting Switch
13	532121248	Bushing Snap Blk Nyl 50 Id
14	872050412	Bolt Rdhd Sht Nk 1/4-20 x1-1/2
15	532134300	Spacer Split 28 x 96 Yel Zinc
16	532121250	Spring Cprsn 1 27 Blk Pnt
17	532123976	Nut Lock 1/4 Lge Flg Gr 5 Zinc
21	532171852	Bolt Shoulder 5/16-18 UNC-2A
22	873800500	Nut Hex Lock W/Ins 5/16-18
24	819171912	Washer 17/32 x 1-3/16 x 12 Ga.
25	532127018	Bolt Shoulder 5/16-18 x 62

NOTE: All component dimensions given in U.S. inches.
1 inch = 25.4 mm

REPAIR PARTS

TRACTOR - - MODEL NO. YT150 (HEYT155H) PRODUCT NO. 954 17 00-37
DECALS

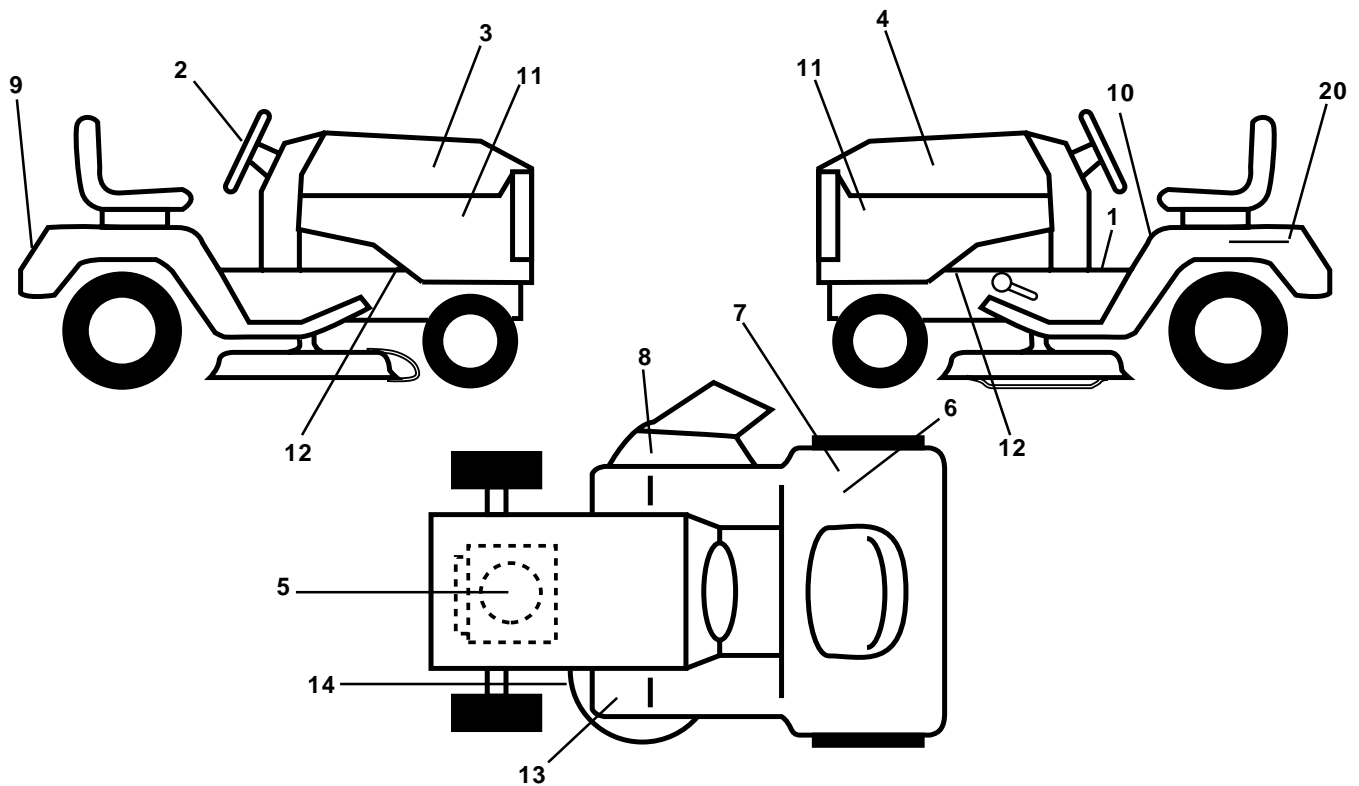

KEY NO.	PART NO.	DESCRIPTION
1	532140837	Decal Saddle Parking
2	532170564	Decal Wheel Steering
3	532151548	Decal Hood RH
4	532151549	Decal Hood LH
5	532170846	Decal HP Engine
6	532126187	Decal 100 DBA
7	532145437	Decal Europe Stand CE
8	532145494	Decal Mower Cut/Finger
9	532150617	Decal Fender Husq
10	532145498	Decal Read Owner's Man Syms
11	532159713	Decal Panel Side B & S Logo

KEY NO.	PART NO.	DESCRIPTION
12	532159736	Decal Chassis Hot Muffler
13	532159737	Decal Brake/Clutch Symbol LT
14	532160396	Decal V-Belt Schematic
20	532145005	Decal Bat Dan/Psn
--	532171284	Pad Footrest LH STLT
--	532171285	Pad Footrest RH STLT
--	532138311	Decal Handle Lft Height Adjust
--	532176248	Manual Operator's (Euro)
--	532176249	Manual Operator's (Scand)
--	532162598	Decal Drawbar Load Limit
Available accessories not included with tractor:		
--	MK420	Mulch Kit w/Blades
--	CE42	Grass Catcher

WHEELS & TIRES

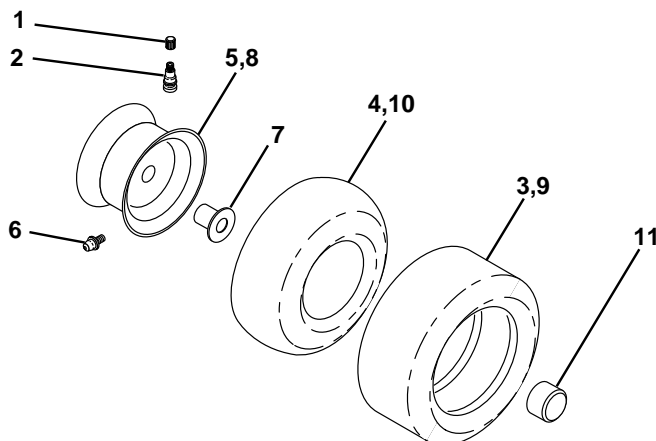

KEY NO.	PART NO.	DESCRIPTION
1	532059192	Cap Valve Tire
2	532065139	Stem Valve
3	532106222	Tire F Ts 15 X 60 - 6 Service
4	532059904	Tube Front (Service Item Only)
5	532138336	Rim Asm 6"front
6	532124957	Fitting Grease (Front Wheel Only)
7	532124959	Bearing Flange (Front Wheel Only)
8	532138337	Rim Asm 8"rear
9	532122082	Tire R Ts 20 x 10-8 C Service
10	532124926	Tube Rear (Service Item Only)
11	532175039	Cap Axle Blk 1 50 X 1 00
--	532144334	Sealant, Tire (10 oz. Tube)

NOTE: All component dimensions given in U.S. inches
1 inch = 25.4 mm

REPAIR PARTS

TRACTOR - - MODEL NO. YT150 (HEYT155H) PRODUCT NO. 954 17 00-37
ENGINE

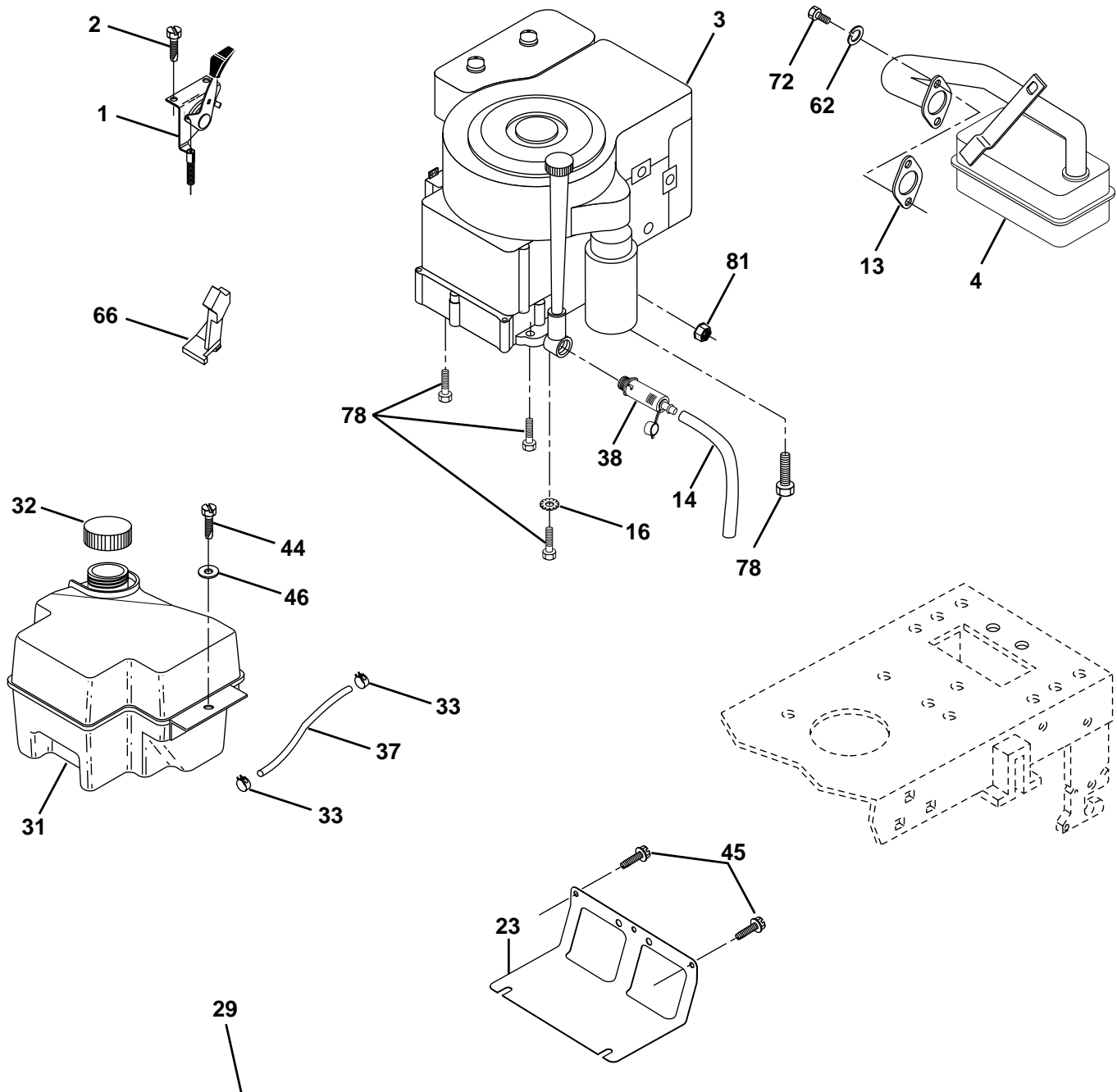

29

OPTIONAL EQUIPMENT
Spark Arrester

REPAIR PARTS

TRACTOR - - MODEL NO. YT150 (HEYT155H) PRODUCT NO. 954 17 00-37
ENGINE

KEY NO.	PART NO.	DESCRIPTION
1	532170865	Control Th/ch Flag
2	817720410	Screw Hex Thd Cut 1/4-20x5/8 T
3	-----	Engine, Briggs Model 287707 (Order parts from engine manufacturer)
4	532137352	Muffler LT B&S 15 HP IC OHV
13	532165291	Gasket
14	532148456	Tube Drain Oil Easy
16	811050600	Washer Lock Ext Tooth 3/8
23	532169837	Shield Browning/Debris Guard
29	532137180	Kit Spark Arrestor (Flat Scrn)
31	532174642	Tank Fuel Front 2 00
32	532140527	Cap Asm Fuel W/sym Vented
33	532123487	Clamp Hose Black
37	532137040	Line Fuel 20"
38	532148315	Plug Drain Oil Easy
44	817670412	Screw Hexwsh Thdrol 1/4-20x3/4
45	817000612	Screw Hexwsh Thdr 3/8-16 x 3/4
46	819091416	Washer 9/32 X 7/8 X 16 Ga
62	810040500	Washer Lock Hvy Hlcl Spr 5/16
66	532127951	Stop Throttle
72	871070512	Screw Hexhd Cap 5/16-18x 3/4
78	817060620	Screw 3/8-16x1-1/4
81	873510400	Nut Keps Hex 1/4-20 Unc

NOTE: All component dimensions given in U.S. inches
1 inch = 25.4 mm

REPAIR PARTS

TRACTOR - - MODEL NO. YT150 (HEYT155H) PRODUCT NO. 954 17 00-37
MOWER DECK

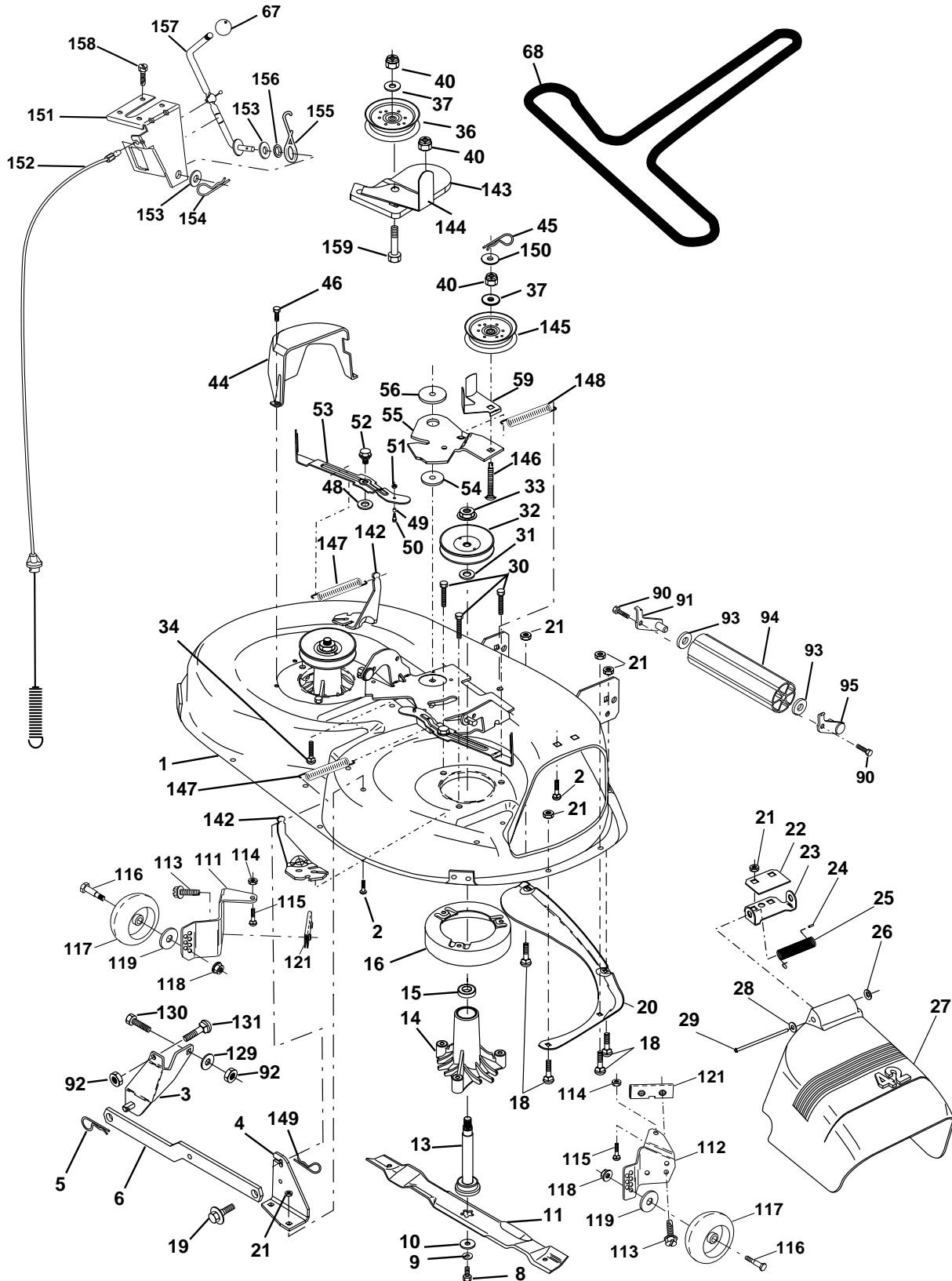

REPAIR PARTS

TRACTOR - - MODEL NO. YT150 (HEYT155H) PRODUCT NO. 954 17 00-37
MOWER DECK

KEY NO.	PART NO.	DESCRIPTION	KEY NO.	PART NO.	DESCRIPTION
1	532165892	Deck Asm MWR 42"weldment	68	532144959	V-Belt Secondary
2	872140506	Bolt Rdhd Sqnk 5/16-18unc X3/4	90	817490612	Screw Thdrol 3/8-16 x 3/4
3	532138017	Bracket Asm Fr Sway Bar 38/42	91	532175746	Bracket Asm Noseroller LH
4	532165460	Bracket Asm Deck 42"sway Bar	92	873800600	Nut Lock Hex W/Ins 3/8-16 Unc
5	532124670	Retainer Spring	93	819171416	Washer 17/32 x 7/8 x 16 Ga.
6	532130832	Arm Suspension Rear	94	532132264	Roller Nose 38 & 42
8	532850857	Bolt 3/8 - 24 X 1.25 Gr 8	95	532175747	Bracket Asm Noseroller RH
9	810030600	Washer Lock Hvy 3/8	111	532155197	Bracket Wheel Gauge LH 42" Deck
10	532140296	Washer Hard Blade Mower	112	532155198	Bracket Gauge Wheel RH 42" Deck
11	532138498	Blade Mower	113	817060514	Screw 5/16-18
13	532137645	Shaft Asm W/lower Bearing	114	873510500	Nut Keps 5/16-18 UNC
14	532128774	Housing Mandrel Vented	115	872110504	Bolt Carriage 5/16-UNC x 1/2
15	532110485	Bearing Ball Mandrel	116	532124842	Bolt Shoulder
16	532174493	Stripper Mower	117	532165746	Wheel Gauge Blk
18	872140505	Bolt Rdhd Sqnk 5/16-18 X 5/8	118	873930600	Nut Centerlock 3/8-16 UNC
19	532132827	Bolt Shoulder	119	819121414	Washer 3/8 x 7/8 x 14 Ga.
20	532159770	Baffle Vortex 42	121	532143723	Bracket Extruded Gauge Wheel
21	873680500	Nut Crownlock 5/16-18 UNC	129	819131312	Washer 13/32 x 13/16 x 12 Ga.
22	532134753	Stiffener Bracket 42"deck	130	874780616	Bolt Fin Hex 3/8-16 UNC x 1 Gr. 5
23	532131267	Bracket Deflector Mower 42"	131	872140608	Bolt Rdhd Sqnk 3/8-16 x 1
24	532105304	Cap Sleeve 80x 112 Blk Mower	142	532165890	Arm Spring Brake Mower
25	532123713	Spring Torsion Deflector 2 52	143	532157109	Bracket arm Idler 42"
26	532110452	Nut Push Phos & Oil	144	532158634	Keeper Belt 42" Clutch Cable
27	532171859	Shield Deflector Mower 42" Blk	145	532165888	Pulley Idler Flat
28	819111016	Washer 11/32 X 5/8 X 16 Ga	146	532171977	Bolt Carriage Idler
29	532131491	Rod Hinge 42"6 75 Wlg	147	532131335	Spring Extension
30	532157722	Screw Thdrol Washer Head	148	532169022	Spring Return Idler
31	532129963	Washer Spacer Mower Vented	149	532165898	Retainer Spring Yellow
32	532153535	Pulley Mandrel 42/44/50	150	819091216	Washer 9/32 x 3/4 x 16 Ga.
33	532137266	Nut 9/16 Toplock Fing Oil Dip	151	532169670	Bracket Clutch Cable
34	872110614	Bolt Rdhd 3/8-16uncx1-3/4 Gr5	152	532169676	Cable Clutch 42"
36	532131494	Pulley Idler Flat 3 060	153	532169674	Washer Flat 3/8" Type B
37	819131316	Washer 13/32 X 13/16 X 16	154	532169675	Spring Retainer
40	873680600	Nut Crownlock 3/8-16 UNC	155	532169671	Spring Retention Cltch Cab
44	532140088	Guard Mandrel LH Black	156	532169672	Spacer Clutch Cable
45	532124788	Spring Retainer 1" Zinc/cad	157	532169669	Rod Clutch Cable 3/8"
46	532137729	Screw Hex Thd Cut 1/4-20x5/8 T	158	817720410	Screw Hex Thd Cut 1/4-20 x 5/8
48	532133944	Washer Hardened Smaller	159	872140614	Bolt Rdhd Sqn 3/8-16 UNC x 1-3/4
49	532174284	Roller Asm Cam Follower 42"dec	--	532130794	Mandrel Asm Service (Includes Key
50	532131340	Bolt Shldr 10-24 Zinc Gr 5 42"			Nos. 8-10, 13-15, 31 and 33)
51	532069180	Nut Lock #10-24 Unc	--	532171491	Deck Serv 42"mch S Bar Multi-Lang
52	532139888	Bolt Shoulder 5/16-18 Unc Blkz			(Standard Deck - Order noseroller,
53	532131845	Arm Asm Pad Brake			mulch cover and gauge wheel
54	532133943	Washer Hardened			components separately)
55	532155046	Arm Idler 42"mower LT/YT			
56	532165723	Spacer Retainer Mower			
59	532141043	Guard TUV Idler			
67	532106932	Knob Rd 3/8-16 Plstc Thds Blk			

NOTE: All component dimensions given in U.S. inches
1 inch = 25.4 mm

REPAIR PARTS

TRACTOR - - MODEL NO. YT150 (HEYT155H) PRODUCT NO. 954 17 00-37
MOWER LIFT

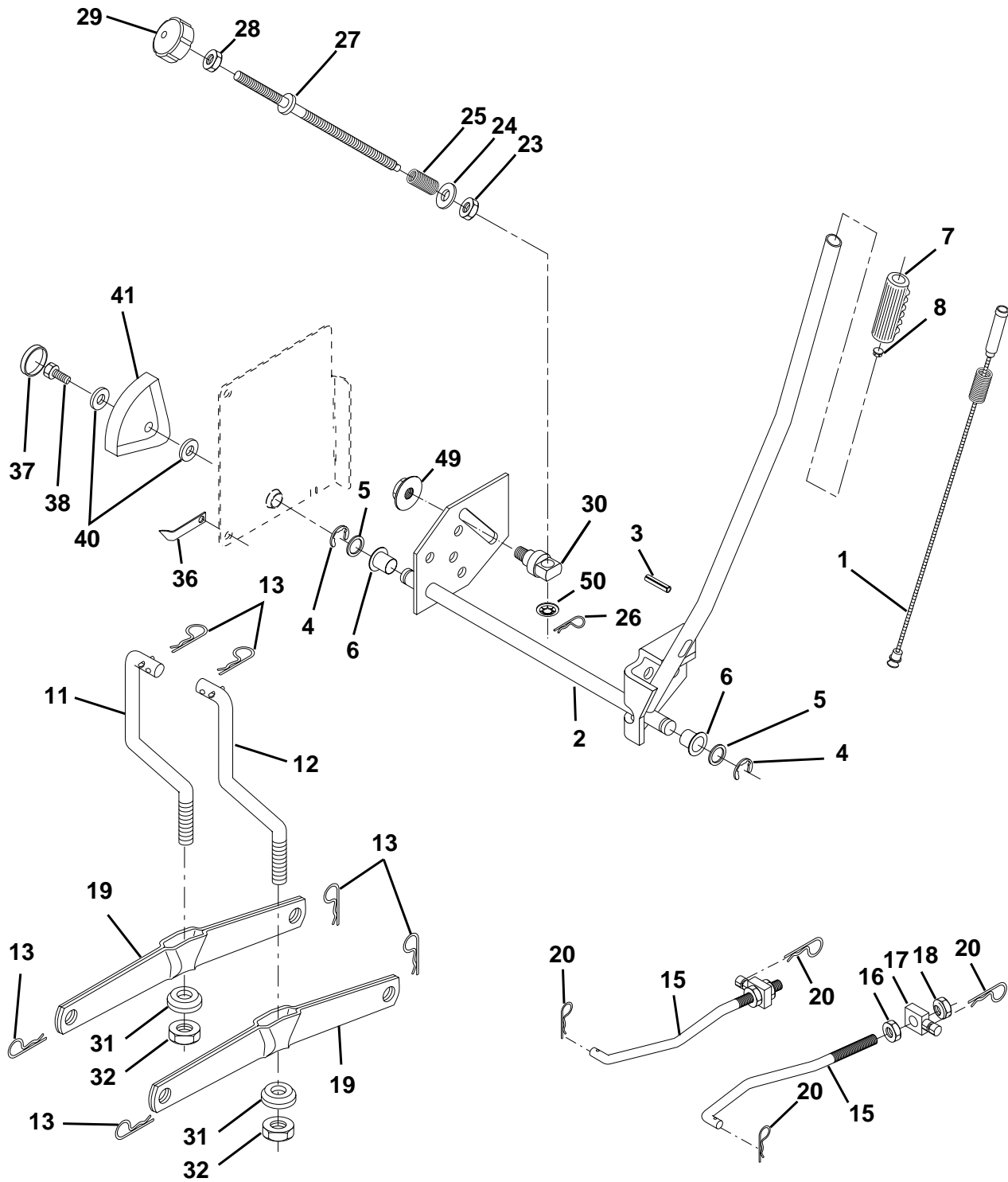

REPAIR PARTS

TRACTOR - - MODEL NO. YT150 (HEYT155H) PRODUCT NO. 954 17 00-37
MOWER LIFT

KEY NO.	PART NO.	DESCRIPTION
1	532159460	Wire Asm Inner W/plunger 17 32
2	532159471	Shaft Asm Lift LH Inf Hgt P/L
3	532105767	Pin Groove 1 500 Zinc
4	812000002	E Ring#5133-62
5	819211621	Washer 21/32 X 1 X 21 Ga
6	532120183	Bearing Nylon Blk 629 Id
7	532125631	Grip Handle
8	532124526	Button Plunger
11	532139865	Link Lift LH
12	532139866	Link Lift RH
13	532124670	Retainer Spring
15	532173288	Link Front
16	873350800	Nut Jam Hex 1/2-13 Unc
17	532130171	Trunnion Blk Zinc
18	873800800	Nut Lock W/wsh 1/2-13unc
19	532139868	Arm Suspension Rear
20	532163552	Retainer Spring
23	532110807	Nut Special
24	819131016	Washer 13/32 X 5/8 X 16 Ga
25	532124874	Spring 2-1/8"
26	532169484	Retainer Clip
27	532126971	Rod Adj Lift Zinc 7 49 Wrk Lg
28	873350600	Nut Hex Jam 3/8-16 Unc
29	532138057	Knob Inf 3/8-16 Unc Blk W/sym
30	532150233	Trunnion Inf Height
31	532169865	Bearing pvt. Lift
32	873540600	Nut Crownlock 3/8-24
36	532155097	Pointer pnt Height Ind.
37	532123935	Plug hole Blk 1.485/1.515 Dia
38	817060516	Screw 5/16-18 x 1 Smgml Tap/R
40	819112410	Washer 11/32 x 1-1/2 10 Ga
41	532155098	Indicator Height
49	532145212	Nut Hex Flange Lock
50	532110452	Push Nut

NOTE: All component dimensions given in U.S. inches
1 inch = 25.4 mm

TRACTOR - - MODEL NO. YT150 (HEYT155H) PRODUCT NO. 954 17 00-37 SCHEMATIC

