

YTH 1542 XP A

954567253

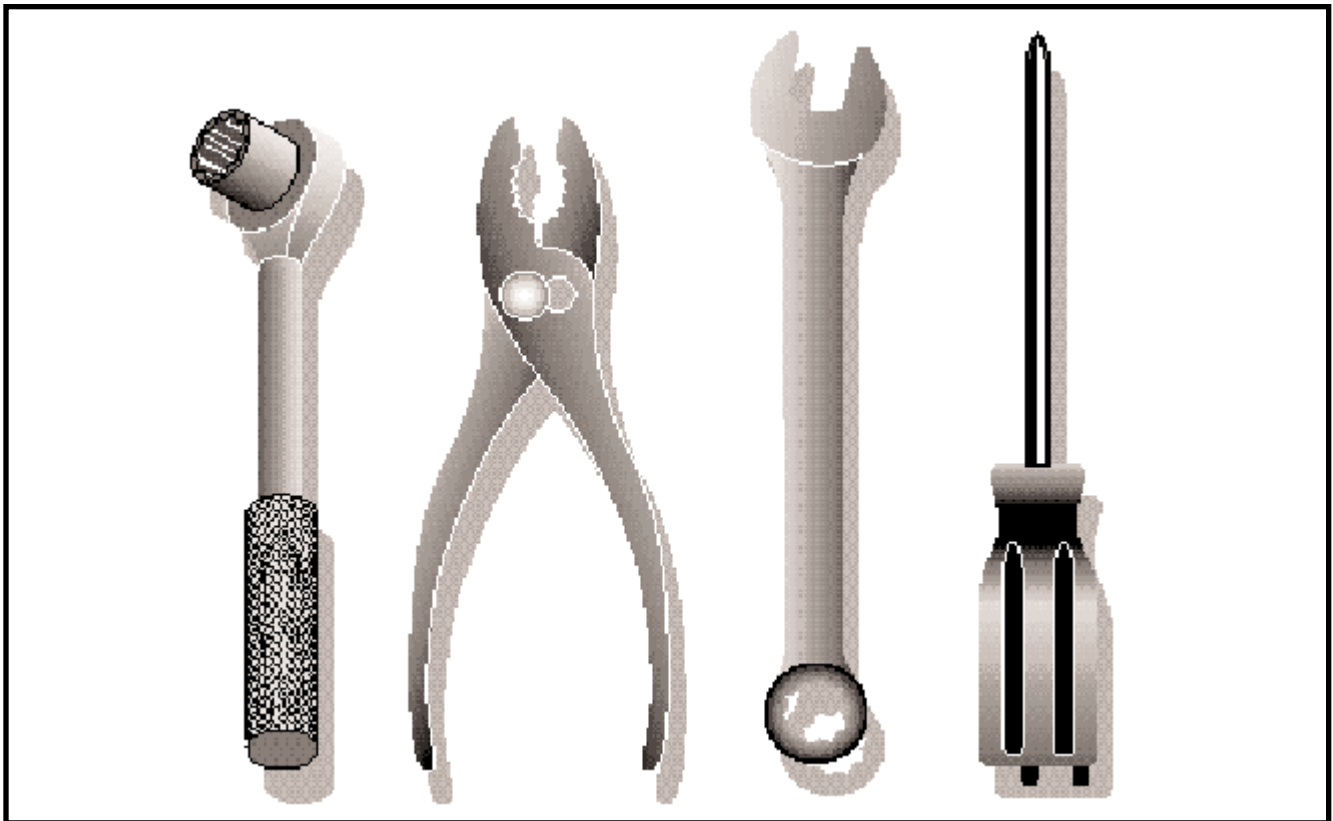

Repair Parts Manual

Ride Mower

TRACTOR - MODEL NO. YTH1542XP (YTH1542XPA), PRODUCT NO. 954 56 72-53 SCHEMATIC

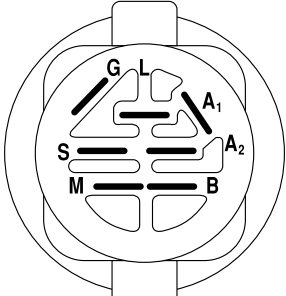
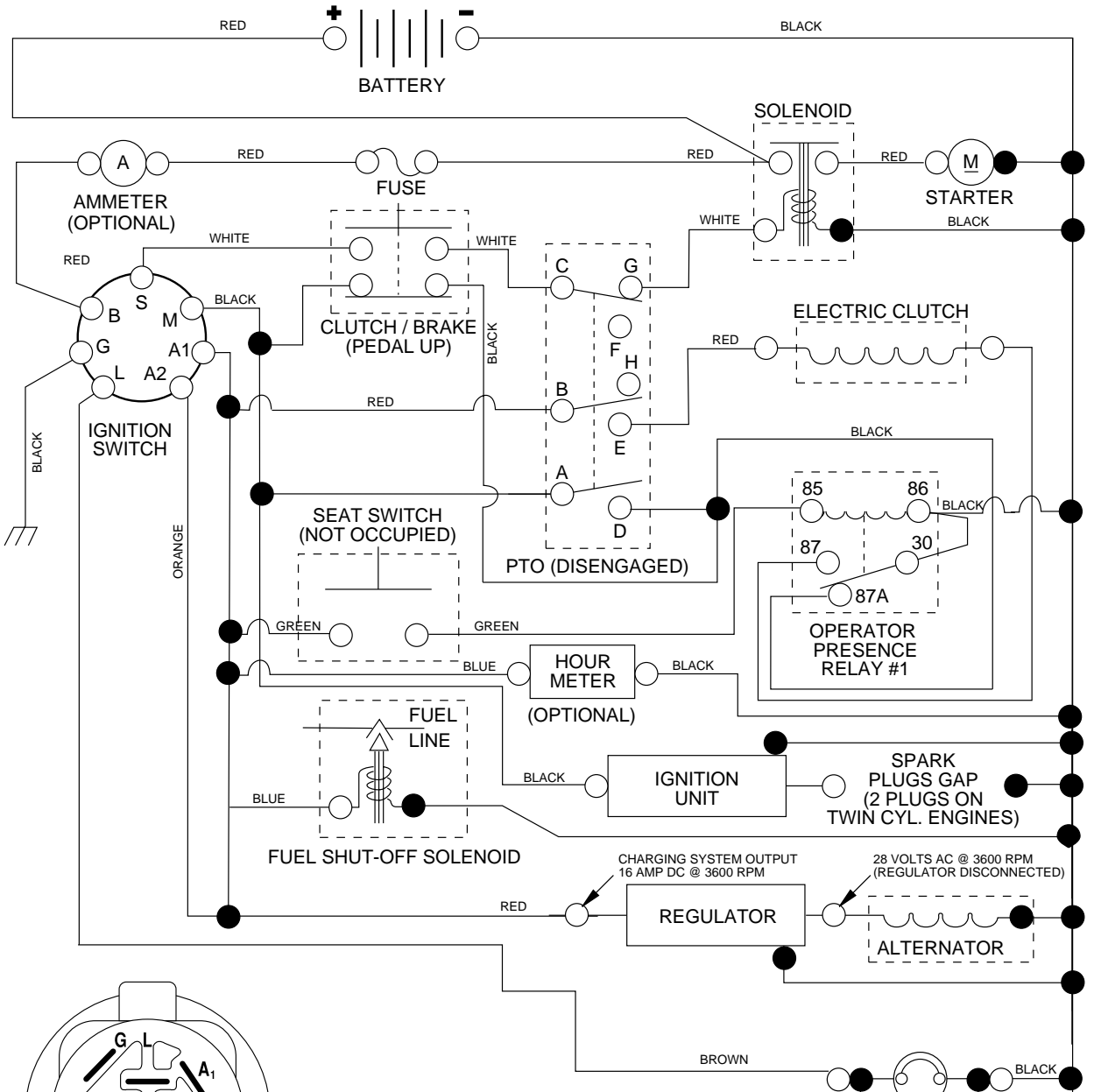

IGNITION SWITCH

POSITION	CIRCUIT	"MAKE"
OFF	M+G+A1	NONE
RUN/LIGHT	B+A1	A2+L
RUN	B+A1	NONE
START	B + S + A1	NONE

WIRING INSULATED CLIPS
NOTE: IF WIRING INSULATED CLIPS WERE REMOVED FOR SERVICING OF UNIT, THEY SHOULD BE REPLACED TO PROPERLY SECURE YOUR WIRING.

PTO SWITCH

POSITION	CIRCUIT
OFF	C + G, B + H
ON	C + F, B + E, A + D

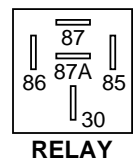
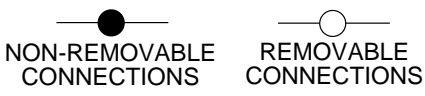

RELAY

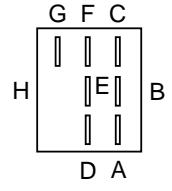

REPAIR PARTS

TRACTOR - MODEL NO. YTH1542XP (YTH1542XPA), PRODUCT NO. 954 56 72-53
ELECTRICAL

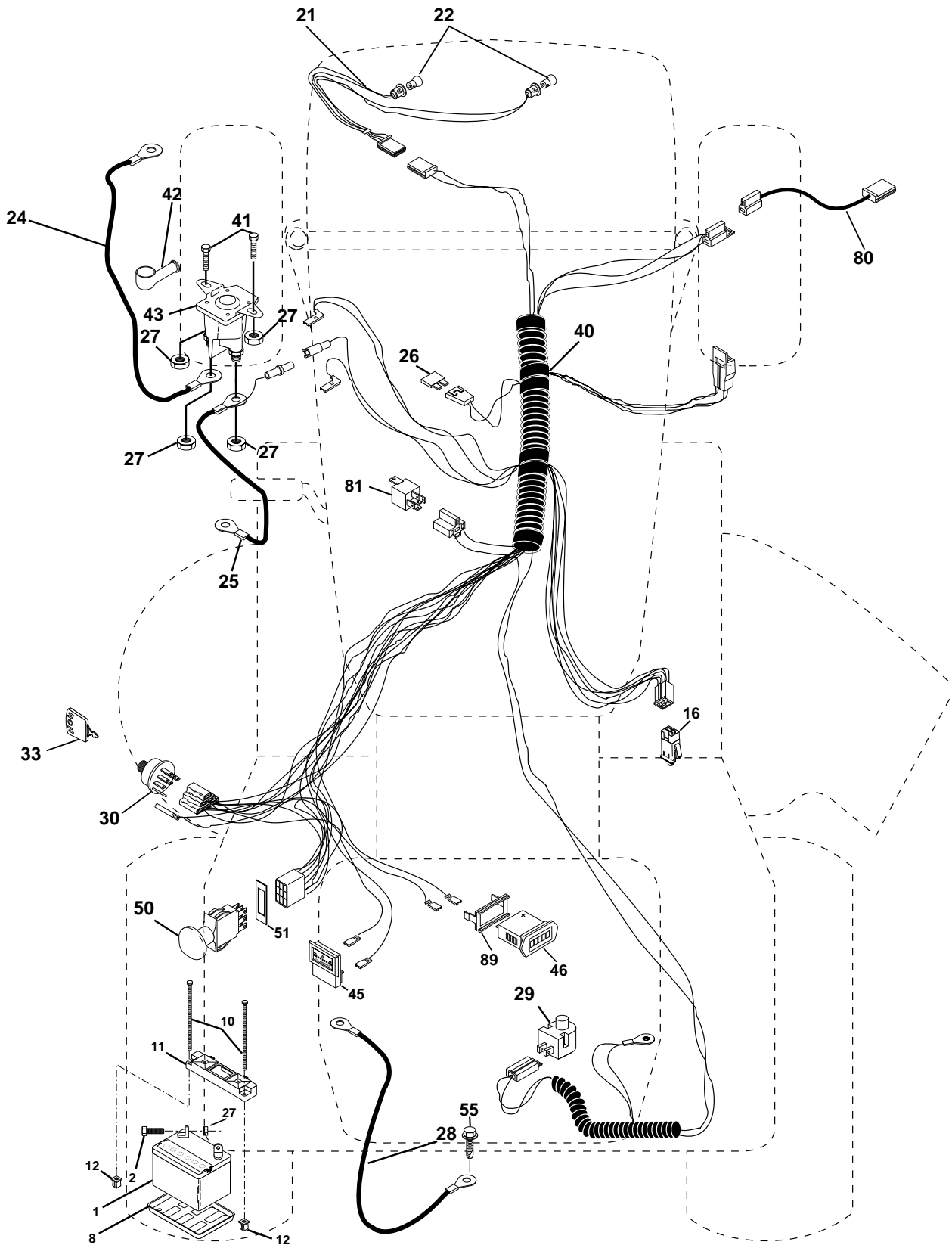

REPAIR PARTS

TRACTOR - MODEL NO. YTH1542XP (YTH1542XPA), PRODUCT NO. 954 56 72-53
ELECTRICAL

KEY NO.	PART NO.	DESCRIPTION
1	532144925	Battery 12 Volt 25 AMP
2	874760412	Bolt Hex Hd 1/4-20unc X 3/4
8	532124886	Tray Battery
10	532145211	Bolt Btr Frt 1/4-20 x 7.5
11	532150109	Hold down Battery Frt Mount
12	532145769	Nut Push Nylon 1/4 Batt Frt
16	532153664	Switch Interlock Push-In
21	532166181	Harness Asm Light W/4152j
22	532004152	Bulb Light #1156
24	532146148	Cable Battery 6 Ga 22" red
25	532108423	Cable Battery 6 Ga 16" red
26	532175158	Fuse
27	873510400	Nut Keps Hex 1/4-20 Unc
28	532145491	Cable Ground
29	532160784	Switch Plunger Nc Gray
30	532175566	Switch Ign
33	532140401	Key Ign Generic
40	532170221	Harness Ign.
41	871110408	Bolt Blk Fin Hex 1/4 - 20 x 1/2
42	532131563	Cover Terminal Red
43	532175141	Solenoid
45	532122822	Ammeter
46	532169635	Meter Hour
50	532174651	Switch PTO
51	532140405	Ring Retainer PTO
55	817490508	Screw Thdrol 5/16-18 x 1/2
80	532146685	Harness Clutch Evx
81	532109748	Relay Asm.
89	532169639	Bracket Snap-In Hourmeter

NOTE: All component dimensions given in U.S. inches.
1 inch = 25.4 mm.

REPAIR PARTS

TRACTOR - MODEL NO. YTH1542XP (YTH1542XPA), PRODUCT NO. 954 56 72-53
CHASSIS AND ENCLOSURES

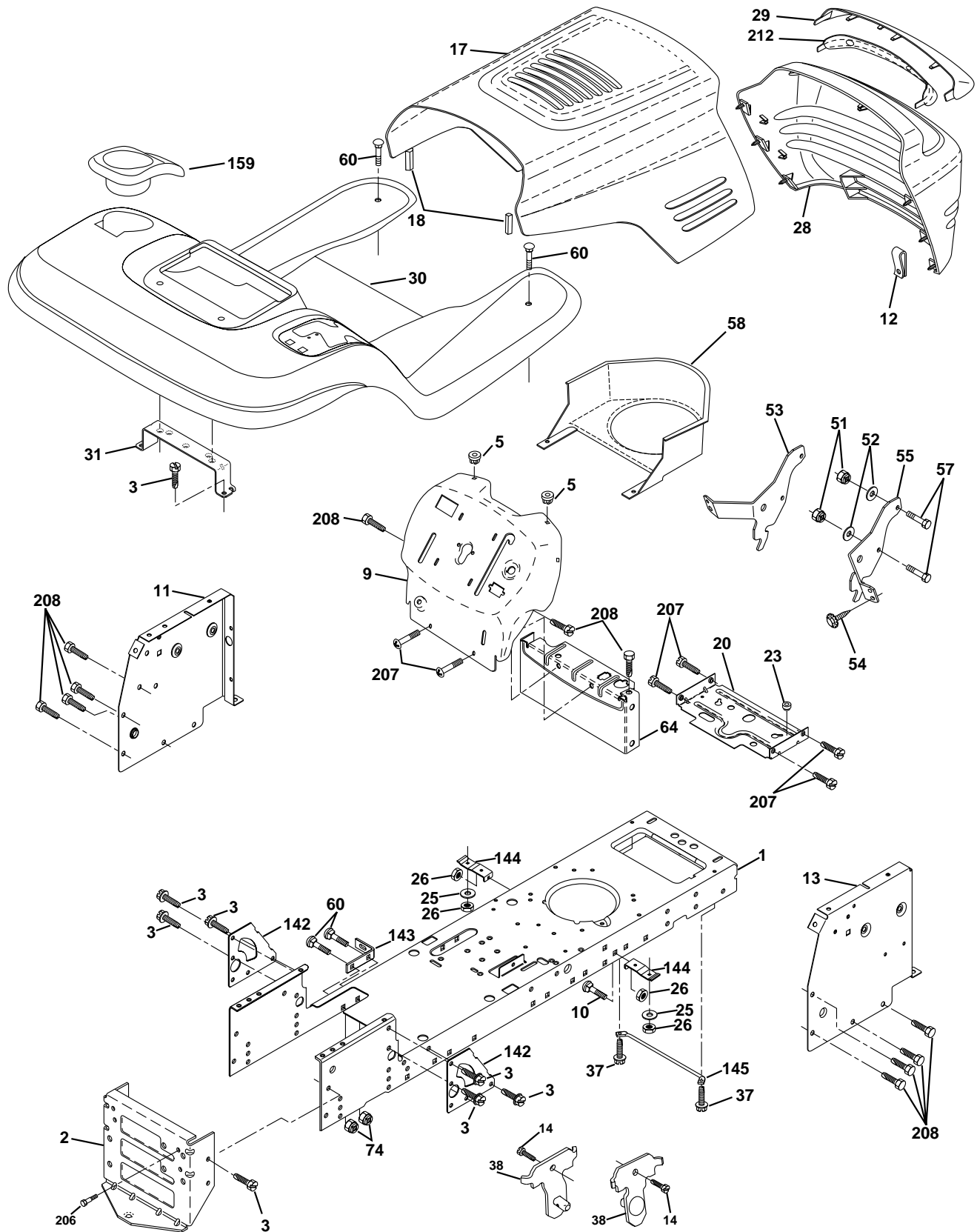

REPAIR PARTS

TRACTOR - MODEL NO. YTH1542XP (YTH1542XPA), PRODUCT NO. 954 56 72-53 CHASSIS AND ENCLOSURES

KEY NO.	PART NO.	DESCRIPTION
1	532174619	Chassis stamping
2	532176554	Drawbar, 12 Ga.
3	817060612	Screw 3/8-16x3/4
5	532155272	Bumper Hood/Dash
9	532178179	Dash Slkscr
10	872140608	Bolt Carriage 3/8-16 x 1
11	532155927	Panel Dash Lh
12	532145660	Clip Tinnerman
13	532172106	Panel Dash Rh
14	817490608	Screw Thdrol 3/8-16 x 1/2
17	532162237	Hood LT/PL
18	532126938	Bumper Hood
20	532156437	Plate Mtg Battery Fuel Tank Fr
23	532124028	Bushing
25	819131312	Washer 13/32 X 13/16 X 12 Ga
26	873800600	Nut Lock Hex w/Ins. 3/8-16 Unc
28	532170475	Grille/Lens Asm
29	532176645	Lens
30	532171625	Fender
31	532139976	Bracket Fender
37	817490508	Screw Thdrol 6/16-18 x 1/2 TYT
38	532169834	Bracket Asm Pivot Mower Rear
44	532140675	Strap Asm
51	873800400	Nut Lock w/Insert 1/4-20 Unc
52	819091416	Washer 9/32 x 7/8 x 16 Ga.
53	532144697	Bracket Grille Lh
54	532161464	Screw Hex Wsh 8-18 x 7/8
55	532144696	Bracket Grille Rh
57	874780412	Bolt Hex 1/4-20 x 3/4
58	532162266	Air Duct Engine
60	872140606	Bolt Rdhd Sqnk 3/8-16unc x 3/4
64	532154798	Dash Lower STLT
142	532165867	Plate Reinforcement STLT
143	532154966	Bracket Swaybar Chassis
144	532154207	Bracket Footrest
145	532156524	Rod Pivot Chassis/Hood
159	532166508	Cupholder
195	532177070	Panel Pnt Fend
196	817580408	Screw Tap Tite 1/4-20 x 1/2
206	532170165	Bolt Shoulder 5/16-18 TT
207	817670508	Screw Thdrol 5/16-18 x 1/2
208	817670608	Screw Thdrol 3/8-16 x 1/2
212	532156229	Insert Lens Reflective

NOTE: All component dimensions given in U.S. inches
1 inch = 25.4 mm

REPAIR PARTS

TRACTOR - MODEL NO. YTH1542XP (YTH1542XPA), PRODUCT NO. 954 56 72-53
DRIVE

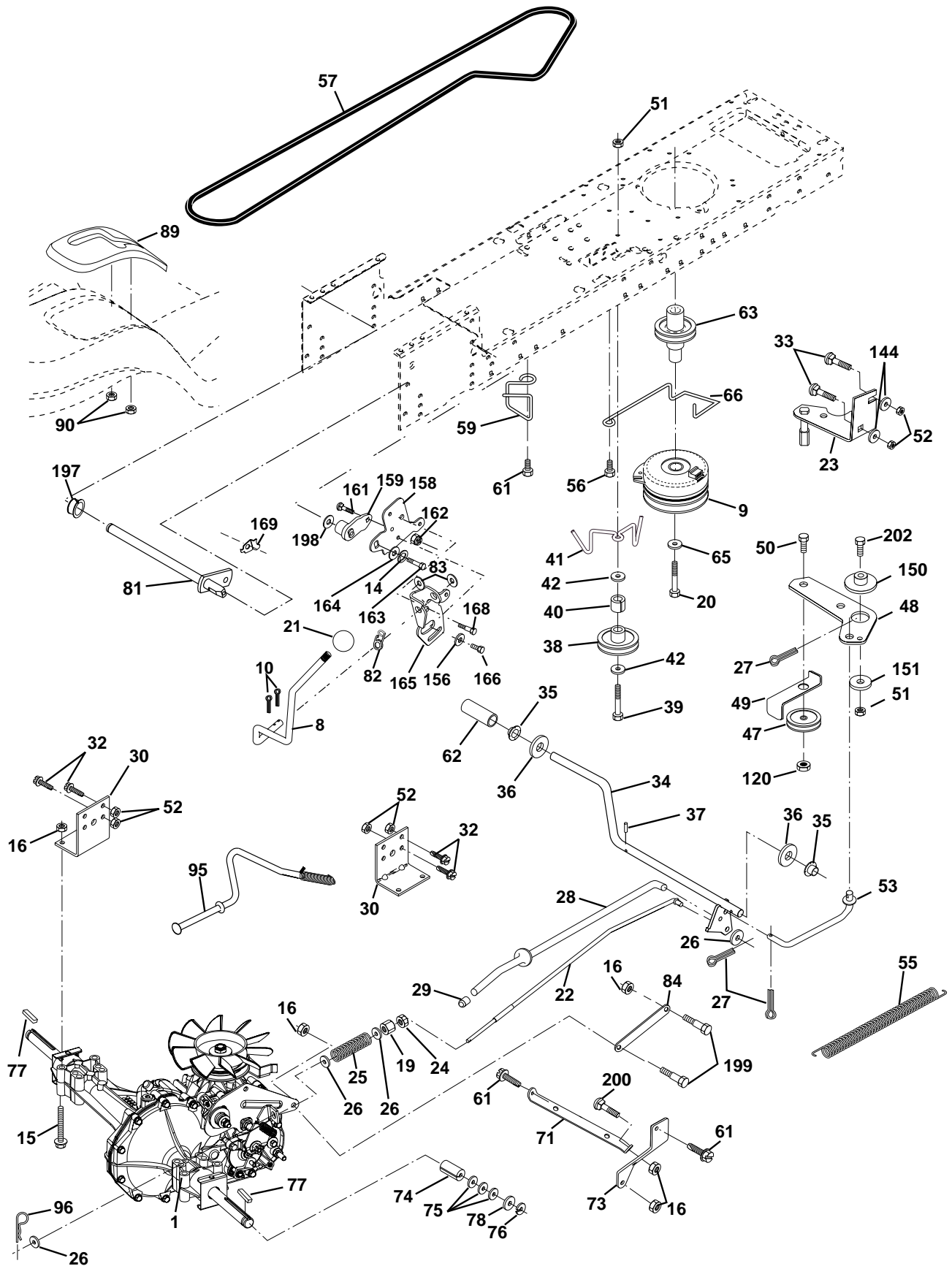

REPAIR PARTS

TRACTOR - MODEL NO. YTH1542XP (YTH1542XPA), PRODUCT NO. 954 56 72-53
DRIVE

KEY PART NO. NO.	DESCRIPTION	KEY PART NO. NO.	DESCRIPTION
1	----- Transaxle Hydro Gr. 314-0510 (Order parts from transaxle mfg.)	61	817060612 Screw 3/8-16 x 3/4
8	532165866 Rod Shift Fender	62	532124872 Cover, Pedal
9	532160889 Clutch Electric	63	532175414 Pulley, Engine
10	876020416 Pin Cotter 1/8 x 1 CAD	65	810040700 Washer Lock Hvy HLCL Spr 7/16
14	810040400 Washer Lock Hvy Helical	66	532154778 Keeper Belt Engine
15	874490544 Bolt Hex 5/16-18 Gr. 5	71	532169183 Strap Torque Lh
16	873800500 Nut Lock Hex W/Ins. 5/16-18 Unc P	73	532169182 Strap Torque Rh
19	873800600 Nut Lock Hex W/Ins 3/8-16 Unc	74	532137057 Spacer, Axle
20	532150350 Bolt Hex	75	532121749 Washer 25/32 x 1-1/4 x 16 Ga.
21	532140845 Knob Deluxe 1/2-13 UNC BLK/BLK	76	812000001 E-Ring
22	532169498 Rod, Brake Hydro	77	532123583 Key, Square
23	532171258 Bracket Asm. Anti-Rot EVX	78	532121748 Washer 25/32 x 1-5/8 x 16 Ga
24	873350600 Nut Hex Jam 3/8-16 UNC	81	532165596 Shaft Asm Cross Tapered
25	532106888 Spring, Brake Rod	82	532165711 Spring Torsion
26	819131316 Washer	83	819171216 Washer 17/32 x 3/4 x 16 Ga.
27	876020412 Pin Cotter 1/8 x 3/4 CAD.	84	532169594 Link Transaxle
28	532175765 Rod, Parking Brake	89	532166510 Console, Hydro
29	532071673 Cap, Parking Brake	90	532124346 Nut Self-Thd Wsh-Hd 1/4
30	532169592 Bracket, Transaxle	95	532170201 Control Asm. Bypass Hydro
32	874760512 Bolt Hex Hd 5/16-18 Unc x 3/4	96	532124788 Retainer Spring 1" Zinc/Cad
33	872140506 Bolt Carriage 5/16-18 UNC x 3/4	120	873900600 Nut Lock Flg 3/8-16
34	532175578 Shaft, Foot Pedal	144	819111016 Washer 11/32 x 5/8 x 16 Ga.
35	532120183 Bearing, Nylon	150	532175456 Spacer Retainer
36	819211616 Washer	151	819133210 Washer 13/32 x 2 x 10 Ga.
37	532124963 Pin, Roll	156	532166002 Washer Srrted 5/16 ID X 1 X .125
38	532165936 Pulley, Flat Composite	158	532165589 Bracket Shift Mount
39	874760648 Bolt Fin Hex 3/8-16 x 3	159	532165494 Hub Tapered Flange Shift LT
40	532175461 Spacer Split	161	872140406 Bolt Rdhd Sqnk 1/4-20 x 3/4 Gr. 5
41	532175556 Keeper, Belt Idler	162	873680400 Nut Crownlock 1/4-20 Unc
42	819131312 Washer 13/32 x 13/16 x 12 Ga	163	874780416 Bolt Hex Fin 1/4-20 Unc x 1 Gr. 5
47	532127783 Pulley, Idler, V-Groove Plastic	164	819091010 Washer 5/8 x .281 x 10 Ga.
48	532154407 Bellcrank Clutch Grnd Drv Stl	165	532165623 Bracket Pivot Lever
49	532123205 Retainer, Belt Style Spring	166	532166880 Screw 5/16-18 x 5/8
50	874760624 Bolt Hex Hd 3/8-16 Unc x 1-1/2	168	532165492 Bolt Shoulder 5/16-18 x .561
51	873680600 Nut	169	532165580 Plate Fastening LT
52	873680500 Nut Crown Lock 5/16-18	197	532169613 Nyliner Snap-In 5/8" ID
53	532105710 Link, Clutch	198	532169593 Washer Nyl 7/8ID x .105 Hyd
55	532105709 Spring, Return, Clutch	199	532169612 Bolt Shoulder 5/16-18 Unc
56	817060616 Screw 3/8-16 x 1.0	200	872140508 Bolt Rdhd Sqnk 5/16-18 Unc x 1
57	532140294 V-Belt, Ground Drive	202	872110612 Bolt
59	532169691 Keeper, Center Span		

NOTE: All component dimensions given in U.S. inches
1 inch = 25.4 mm

REPAIR PARTS

TRACTOR - MODEL NO. YTH1542XP (YTH1542XPA), PRODUCT NO. 954 56 72-53
STEERING ASSEMBLY

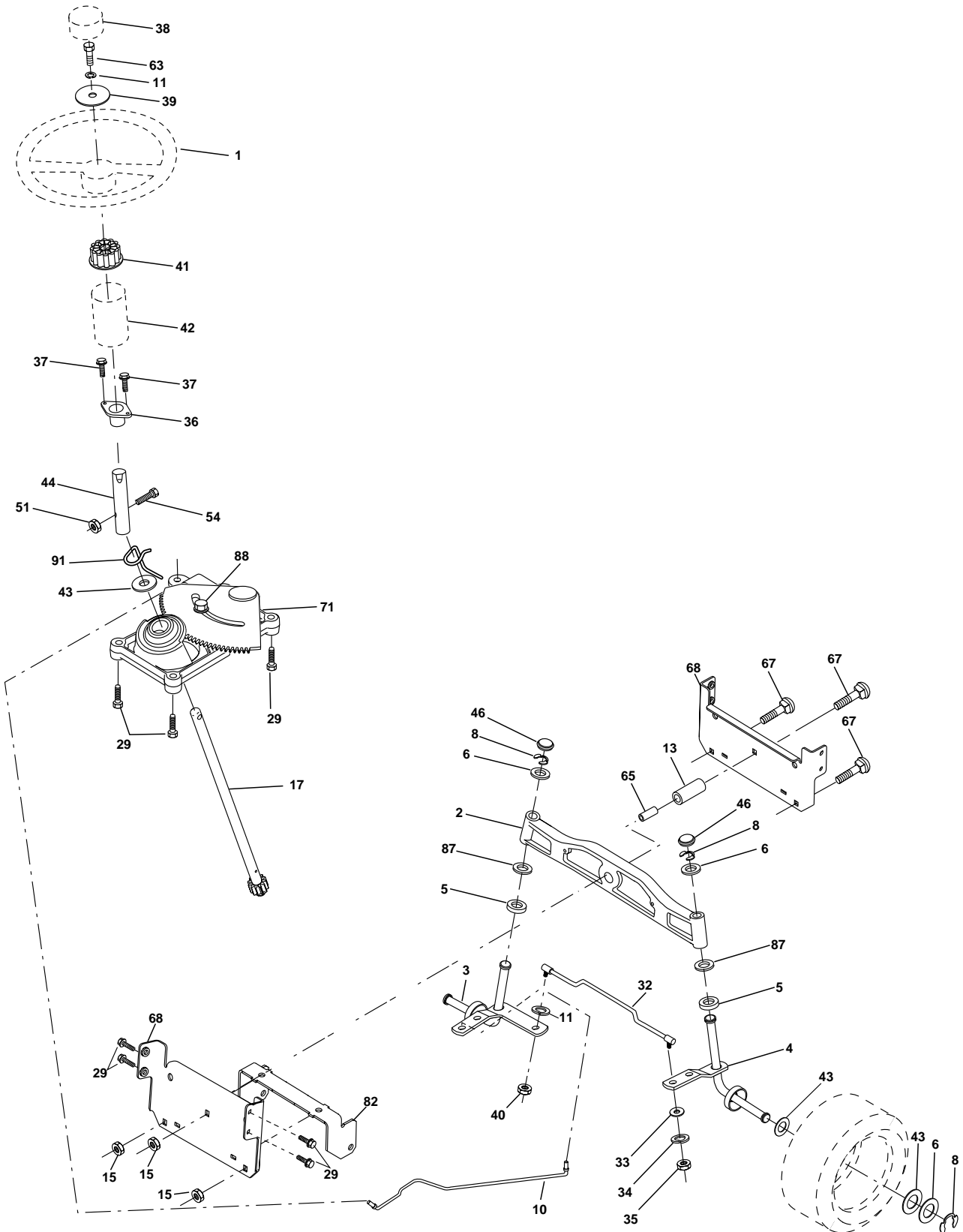

REPAIR PARTS

TRACTOR - MODEL NO. YTH1542XP (YTH1542XPA), PRODUCT NO. 954 56 72-53 STEERING ASSEMBLY

KEY NO.	PART NO.	DESCRIPTION
1	532166627	Wheel Steering
2	532172393	Axle Cast LT Machined
3	532169840	Spindle Asm Cast LH
4	532169839	Spindle Asm Cast RH
5	532124931	Bearing Race Thrust Harden
6	532121748	Washer 25/32 X 1-5/8 X 16 Ga
8	812000029	Ring Klip #t5304-75
10	532175121	Link Drag
11	810040600	Washer Lock Hvy Hlcl Spr 3/8
13	532136518	Spacer Brg Axle Front
15	532145212	Nut Hex Flange Lock Yel D
17	532177876	Shaft Asm Strg
29	817060612	Screw 3/8-16x3/4
32	532171888	Rod Tie
33	819111216	Washer 11/32 x 3/4 x 16 Ga.
34	810040500	Washer Lock Hvy. Helical 5/16 SD
35	873540600	Nut Crown Lock 5/16-24
36	532155099	Bushing Strg
37	532152927	Screw TT #32.5 x 5 x 3/8 Flange
38	532166626	Cap Wheel Steer
39	819132411	Washer 13/32 x 1-1/20 x 11 Ga.
40	532124701	Nut Lock Center 3/8-24 Unf
41	532159945	Adaptor Wheel Strg
42	532169634	Boot Dash Steering
43	532121749	Washer 25/32 X 1 1/4 X 16 Ga
44	532153720	Extension Steering Non-adjust
46	532121232	Cap Spindle Fr Top Blk
51	873800500	Nut Lock Hex W/Ins 5/16-18 UNC
54	874780520	Bolt Fin Hex 5/16-18 UNC x 1-1/4
63	874780616	Bolt Fin Hex 3/8-16 UNC x 1 Gr. 5
65	532160367	Spacer, Brace Axle
67	872140618	Bolt Rdhd 3/8-16 x 2-1/4
68	532169827	Brace, Axle
71	532175146	Steering Asm
82	532169835	Bracket Susp Chassis Front 15"
87	532173966	Washer Flat .781 x 1-1/2 x .14
88	532175118	Bolt Shoulder 7/16-20
91	532175553	Clip Steering

NOTE: All component dimensions given in U.S. inches.
1 inch = 25.4 mm.

REPAIR PARTS

TRACTOR - MODEL NO. YTH1542XP (YTH1542XPA), PRODUCT NO. 954 56 72-53
SEAT ASSEMBLY

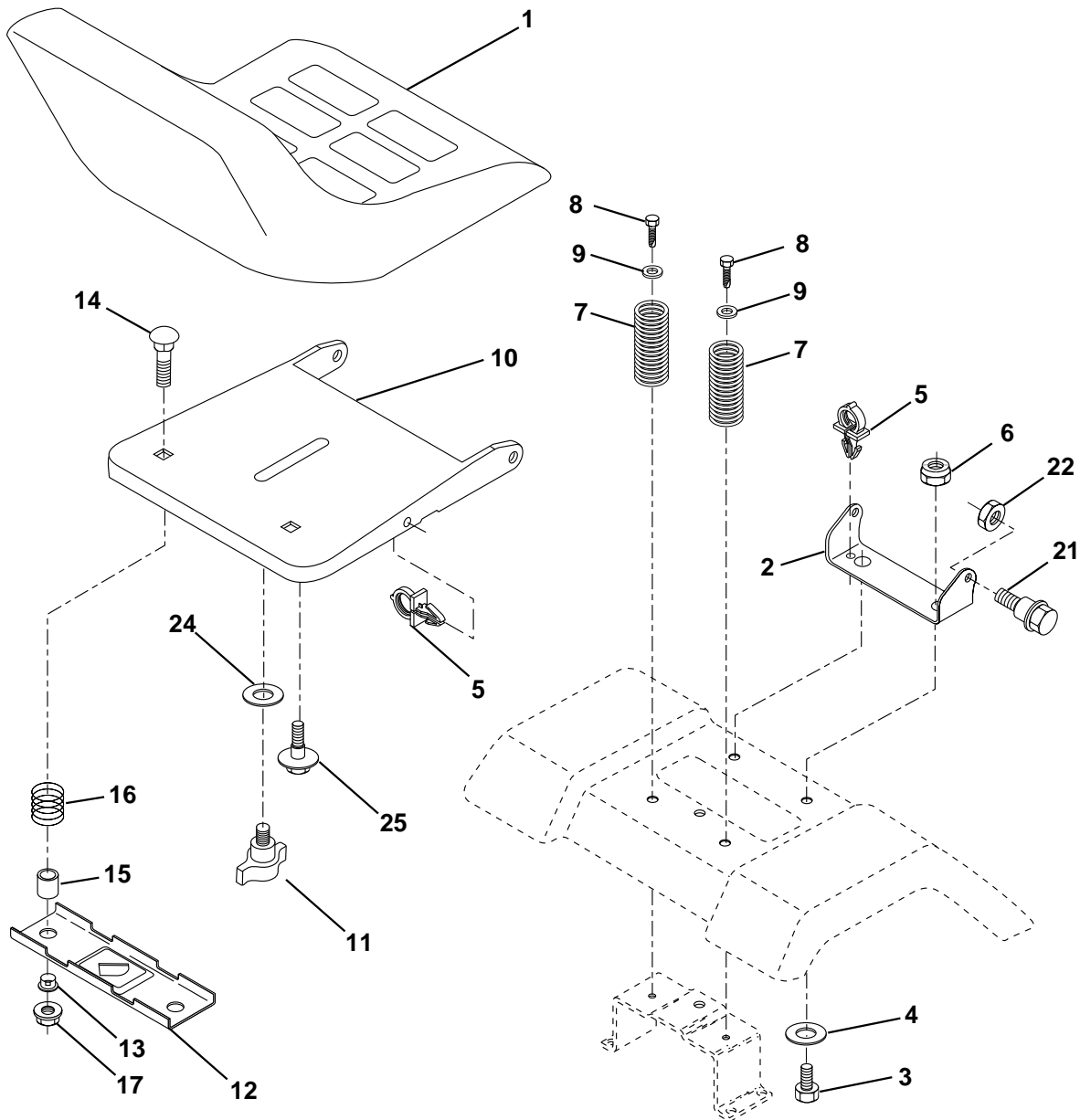

**KEY PART
NO. NO.**

DESCRIPTION

1	532140840	Seat
2	532140551	Bracket Pivot Seat 8 720
3	872110616	Bolt Fin Hex 3/8-16unc x 1
4	819131610	Washer Flat 13/32 x 1 x 10 Ga
5	532145006	Clip Push-In
6	873800600	Nut Hex w/Ins. 3/8-16 Unc
7	532124181	Spring Seat Cprsn 2 250 Blk Zi
8	817000616	Screw 3/8-16 x 1-1/2
9	819131614	Washer 13/32 x 1 x 14 Ga
10	532174894	Pan Seat
11	532166369	Knob Seat Adj Wingnut
12	532121246	Bracket Mounting Switch

**KEY PART
NO. NO.**

DESCRIPTION

13	532121248	Bushing Snap Blk Nyl 50 Id
14	872050412	Bolt Rdhd Sqnk 1/4-20x1-1/2
15	532121249	Spacer Split 28x 96 Yel Zinc
16	532123740	Spring Cprsn
17	532123976	Nut Lock 1/4 Lge Flg Gr 5 Zinc
21	532171852	Bolt Shoulder 5/16-18 Unc
22	873800500	Nut Hex Lock W/Ins 5/16-18
24	819171912	Washer 17/32 X 1-3/16 X 12 Ga.
25	532127018	Bolt Shoulder 5/16-18 X 62
27	817490608	Screw Thdrol 3/8-16 x 1/2
28	532171877	Bolt 5/16-18 x 3/4

NOTE: All component dimensions given in U.S. inches.
1 inch = 25.4 mm

REPAIR PARTS

TRACTOR - MODEL NO. YTH1542XP (YTH1542XPA), PRODUCT NO. 954 56 72-53
DECALS

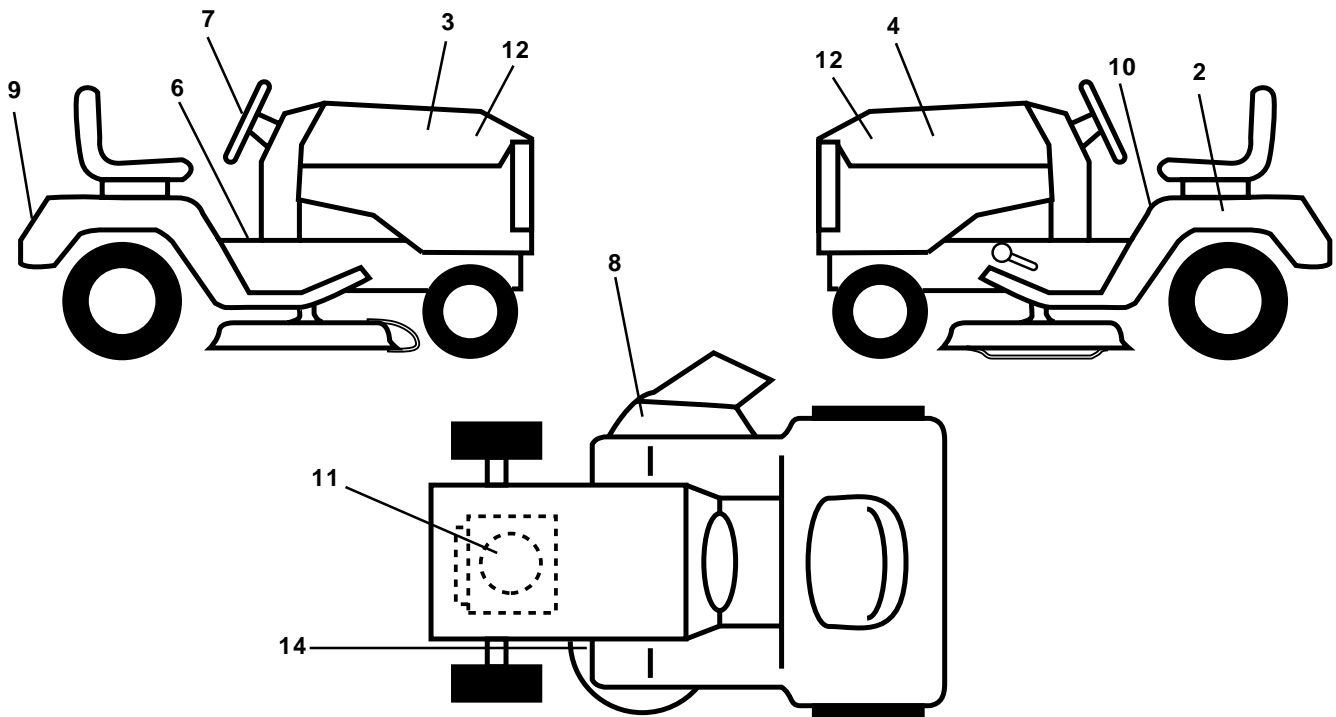

KEY NO.	PART NO.	DESCRIPTION
2	532145005	Decal Battery
3	532177743	Decal Hood RH
4	532177744	Decal Hood LH
6	532157032	Decal Fender Oper
7	532170564	Decal Wheel Steering
8	532170563	Decal Warning
9	532176822	Decal Fender Husq
10	532157140	Decal Fender Danger E/F

KEY NO.	PART NO.	DESCRIPTION
11	532177735	Decal Engine
12	532176871	Decal Hood
14	532160396	Decal V-Belt Schematic
--	532171284	Pad Footrest LH
--	532171285	Pad Footrest RH
--	532138311	Decal Handle Lft Height Adjust
--	532169210	Decal By Pass Lt Hydro
--	532177021	Manual Owner's (English)
--	532177022	Manual Owner's (French)

WHEELS & TIRES

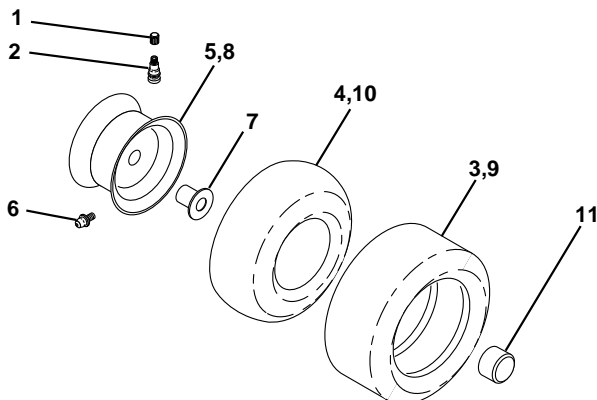

KEY NO.	PART NO.	DESCRIPTION
1	532059192	Cap Valve Tire
2	532065139	Stem Valve
3	532106222	Tire F Ts 15 X 6 0 - 6 Service
4	532059904	Tube Front (Service Item Only)
5	532138336	Rim Asm 6"front Silver Service
6	532124957	Fitting Grease (Front Wheel Only)
7	532124959	Bearing Flange (Front Wheel Only)
8	532138337	Rim Asm 8"rear Silver Service
9	532122082	Tire R Ts 20x10-8 C Service
10	532124926	Tube Rear (Service Item Only)
11	532175039	Cap Axle Blk 1 50 X 1 00
--	532144334	Sealant, Tire (10 oz. Tube)

NOTE: All component dimensions given in U.S. inches
1 inch = 25.4 mm

REPAIR PARTS

TRACTOR - MODEL NO. YTH1542XP (YTH1542XPA), PRODUCT NO. 954 56 72-53
ENGINE

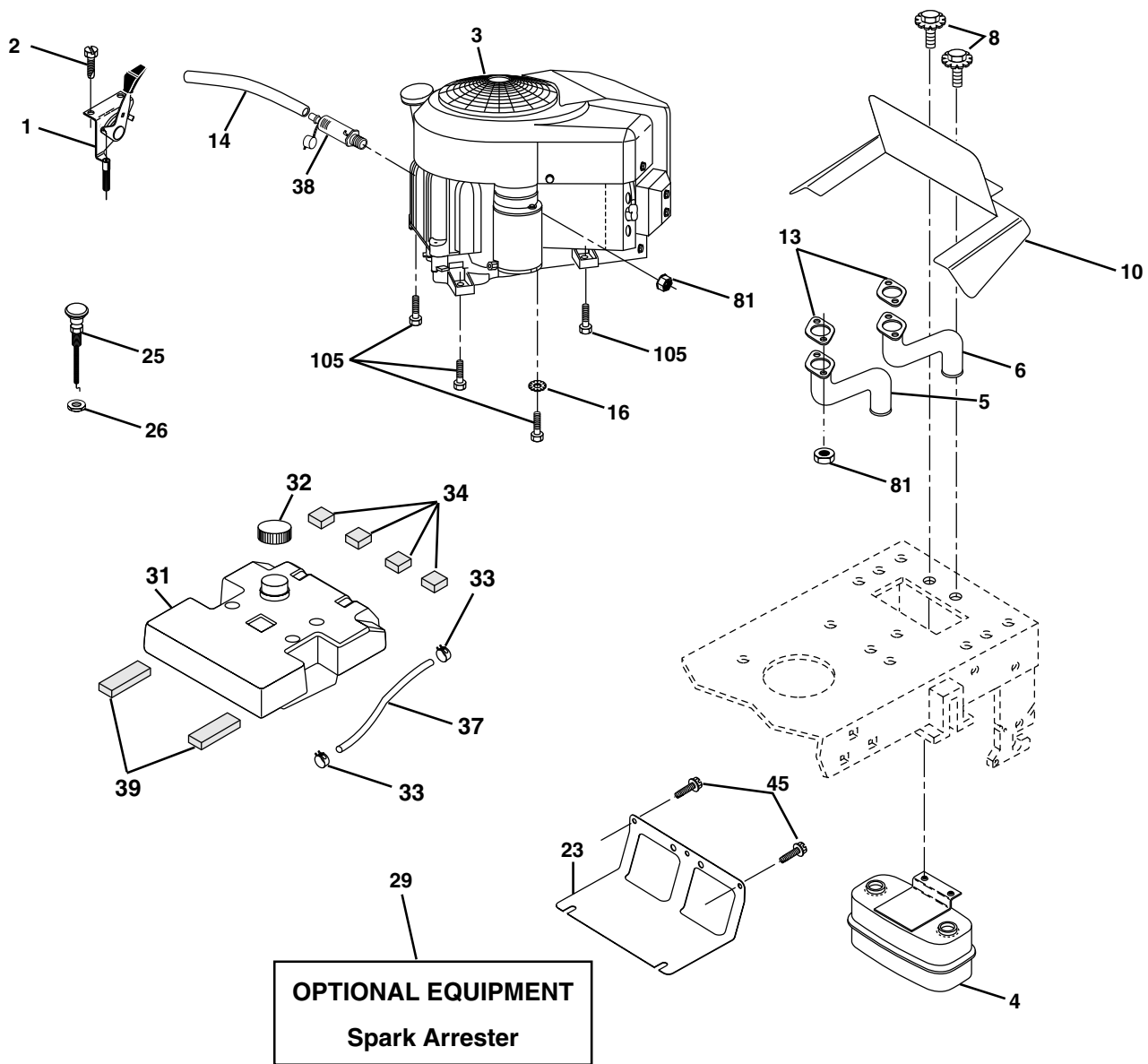

KEY NO.	PART NO.	DESCRIPTION	KEY NO.	PART NO.	DESCRIPTION
1	532170803	Control Throt Flg	26	873920600	Nut, Keps 3/8-24 Unf
2	817720410	Screw Hex Thd Cut 1/4-20x5/8 T	29	532137180	Kit Spark Arrester (Flat Scrn)
3	-----	Engine KAWA FH451V (Order Parts from Engine Manufacturer)	31	532157103	Tank Fuel 3 50 Rear
4	532149723	Muffler Asm Twin Lo-Tone	32	532140527	Cap Asm Fuel Top N/Lany Vented
5	532176067	Exhaust Tube	33	532123487	Clamp Hose Blk
6	532176068	Exhaust Tube	34	532106082	Pad, Spacer
8	532171877	Bolt 5/16-18unc x 3/4 W/Sems	37	532142158	Line Fuel
10	532146629	Shield Browning	38	-----	Plug Drain Oil (Order from Engine Manufacturer)
13	532178084	Gasket Muffler	39	532109227	Pad, Idler
14	532148456	Tube Drain Oil Easy	45	817000612	Screw Hexwsh Thdr 3/8-16 x 3/4
16	811050600	Washer Lock Ext Tooth 3/8	81	532163305	Nut Flange M-8-1.25
23	532169837	Shield Browning	105	817120616	Screw 3/8-16 x 1
25	532132782	Choke Control			

NOTE: All component dimensions given in U.S. inches
1 inch = 25.4 mm

REPAIR PARTS

TRACTOR - MODEL NO. YTH1542XP (YTH1542XPA), PRODUCT NO. 954 56 72-53
MOWER LIFT

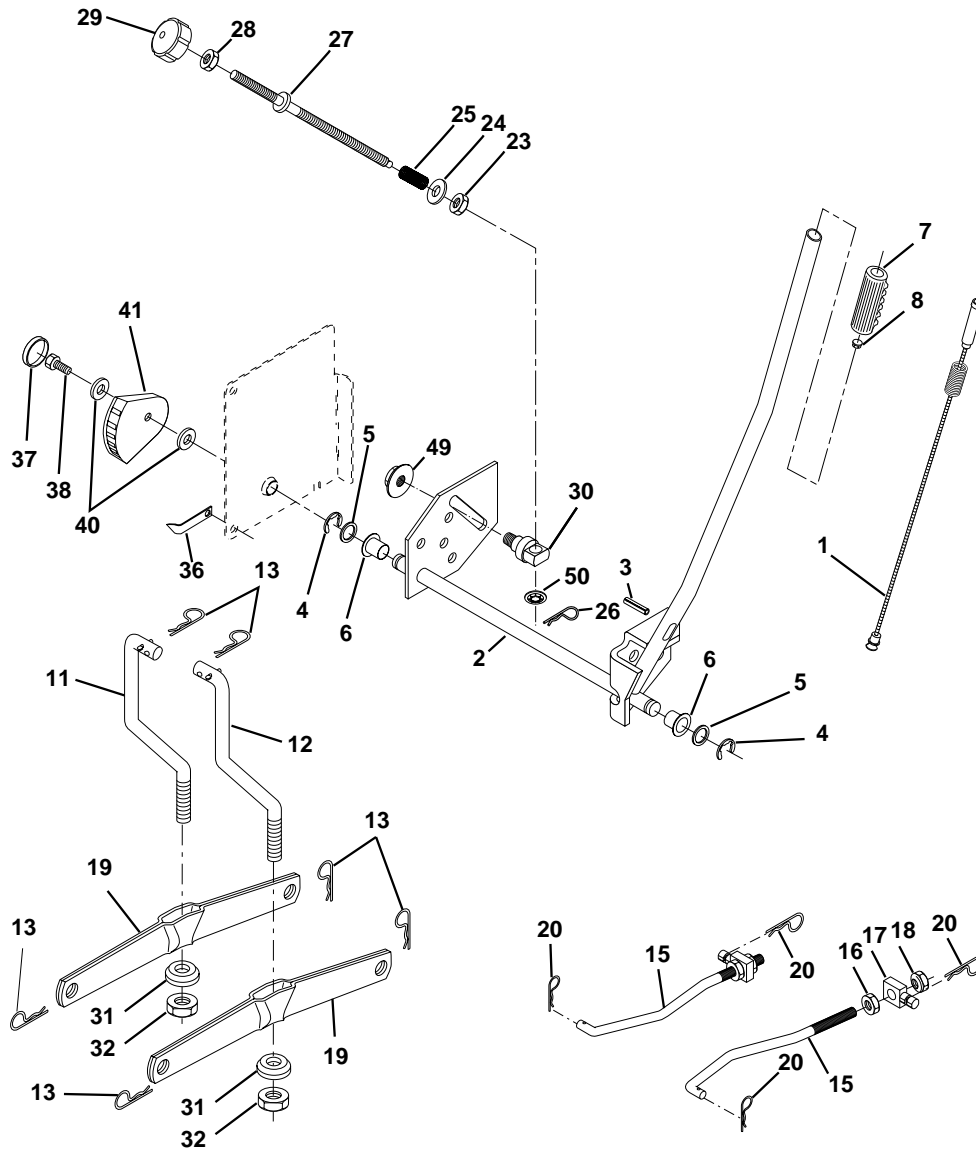

KEY NO.	PART NO.	DESCRIPTION
1	532159460	Wire Asm Inner W/plunger
2	532159471	Shaft Asm Lift RH w/Inf
3	532105767	Pin Groove 1 500 Zinc
4	812000002	E Ring #5133-62
5	819211621	Washer 21/32 X 1 X 21 Ga
6	532120183	Bearing Nylon Blk 629 Id
7	532125631	Grip Handle Fluted Blk
8	532124526	Button Plunger Black
11	532139865	Link Lift LH Fixed Length
12	532139866	Link Lift RH Fixed Length
13	532124670	Retainer Spring
15	532173288	Link Front
16	873350800	Nut Jam Hex 1/2-13 Unc
17	532130171	Trunnion Blk Zinc
18	873800800	Nut Lock w/Wsh 1/2-13unc
19	532139868	Arm Suspension Rear
20	532163552	Retainer Spring
23	532110807	Nut Special

KEY NO.	PART NO.	DESCRIPTION
24	819131016	Washer 13/32 X 5/8 X 16 Ga
25	532124874	Spring 2-1/8"
26	532169484	Retainer Clip
27	532126971	Rod Adj Lift Zinc 7.49 Wrk Lg
28	873350600	Nut Hex Jam 3/8-16 Unc
29	532138057	Knob Inf 3/8-16 Unc Blk W/sym
30	532150233	Trunnion Infin Height
31	532169865	Bearing Pvt Lift
32	873540600	Nut Crownlock 3/8 - 24
36	532155097	Pointer Height Indicator
37	532123935	Plug Hole Blk 1.485/1.515 Dia.
38	817060516	Screw 5/16-18 x 1
40	819112410	Washer 11/32 x 1-1/2 10 Ga.
41	532155098	Indicator Height STLTL
49	532145212	Nut Hex Flange Lock
50	532110452	Nut Phos & Oil

NOTE: All component dimensions given in U.S. inches
1 inch = 25.4 mm

REPAIR PARTS

TRACTOR - MODEL NO. YTH1542XP (YTH1542XPA), PRODUCT NO. 954 56 72-53
MOWER DECK

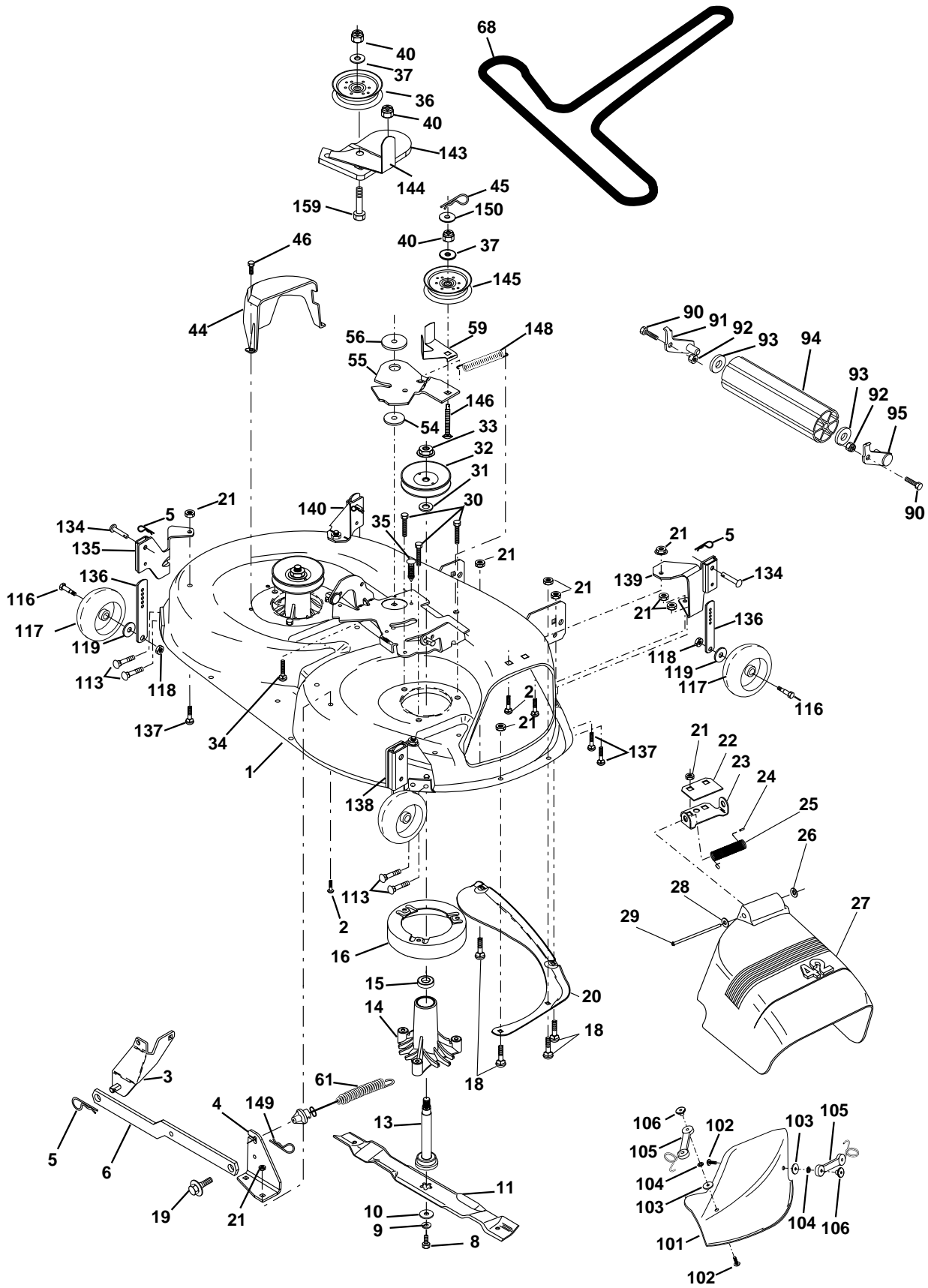

REPAIR PARTS

TRACTOR - MODEL NO. YTH1542XP (YTH1542XPA), PRODUCT NO. 954 56 72-53 MOWER DECK

KEY NO.	PART NO.	DESCRIPTION	KEY NO.	PART NO.	DESCRIPTION
1	532165894	Mower Deck Assembly, 42"	68	532174883	V-Belt
2	872140506	Bolt	90	874760616	Bolt Fin Hex 3/8-16 Unc x 1
3	532138017	Bracket Assembly, Sway Bar, Front	91	532132274	Bracket Asm Noseroller Lh
4	532176935	Bracket Sway Bar 38/42" Deck	92	873800600	Nut Lock Hex w/Ins. 3/8-16 Unc
5	532124670	Retainer Spring	93	819171416	Washer 17/32 x 7/8 x 16 Ga.
6	532130832	Arm, Suspension, Rear	94	532132264	Roller Nose 38"-50"
8	532850857	Bolt, Hex 3/8-24 x 1.25 Gr. 8	95	532132273	Bracket Asm Noseroller Rh
9	810030600	Washer, Lock	101	532136420	Mulcher Cover
10	532140296	Washer, Hardened	102	871081010	Screw
11	532138498	Blade Mower 42" High Perf.	103	819061216	Washer #10
	532134149	Blade, Mulching	104	810071000	Washer, Lock
13	532137645	Shaft Assembly, Mandrel, Vented	105	532160793	Latch Assembly, Bagger
14	532128774	Housing, Mandrel, Vented	106	532125004	Nut, Weld
15	532110485	Bearing, Ball, Mandrel	113	817060514	Screw Tapping 5/16-18 Unc
16	532174493	Stripper, Mower Deck	116	532137644	Bolt, Shoulder
18	872140505	Bolt, Carriage 5/16-18 x 5/8	117	532133957	Wheel, Gauge
19	532132827	Bolt, Shoulder	118	873930600	Nut, Centerlock 3/8-16
20	532159770	Baffle, Vortex	119	819121414	Washer 3/8 x 7/8 x 14 Gauge
21	873680500	Nut Crownlock 5/16-18 UNC	129	819131312	Washer 13/32 x 13/16 x 12 Ga
22	532134753	Stiffener Bracket	130	874780616	Bolt Fin Hex 3/8-16unc x 1 Gr. 5
23	532131267	Bracket, Deflector	131	872140608	Bolt Rdhd Sqnk 3/8-16unc x 1
24	532105304	Cap, Sleeve	134	532156941	Pin Head Rivet
25	532123713	Spring, Torsion, Deflector	135	532178074	Bracket Asm Whl GA R LH
26	532110452	Nut, Push	136	532155986	Bar Adjusting GA WHL
27	532171634	Shield, Deflector	137	872110505	Bolt Carr 5/16-18 x 5/8
28	819111016	Washer 11/32 x 5/8 x 16 Ga.	138	532178075	Bracket Asm Whl GA R RH
29	532131491	Rod, Hinge	139	532178077	Bracket Asm Whl GA F RH
30	532157722	Screw Thdrol Washer Head	140	532178076	Bracket Asm Whl GA F LH
31	532129963	Washer, Spacer	143	532176931	Bracket Arm Idler 42"
32	532173436	Pulley, Mandrel	144	532173441	Keeper Belt 42" Clutch Cable
33	532137266	Nut, Toplock, Flanged	145	532173437	Pulley Idler Flat
34	872110614	Bolt	146	532171977	Bolt Carriage Idler
35	532133835	Fastner, Christmas Tree	148	532169022	Spring Return Idler
36	532173438	Pulley, Idler, Flat	149	532165898	Retainer Spring Yellow Zinc
37	819131316	Washer 13/32 x 13/16 x 16 Gauge	150	819091216	Washer 9/32 x 3/4 x 16 Ga.
40	873680600	Nut Crownlock 3/8-16 UNC	159	872140614	Bolt Rdhd Sq 3/8-16 UNC x 1- 3/4
44	532140088	Guard, Mandrel, L.H.	--	532130794	Mandrel Assembly (Includes Key Numbers 8-10, 13-15, 31 and 32)
45	532124788	Retainer	--	532176050	Mower Deck, Complete (Standard Deck, Order Separately Noseroller, Mulcher Plate and Gauge Wheel Components, Key Nos. 90-95, 101-106 and 111-121)
46	532137729	Screw, Thd. Roll 1/4-20 x 5/8			
54	532133943	Washer, Hardened			
55	532176932	Arm, Idler			
56	532122052	Spacer, Retainer			
59	532173442	Guard, TUV Idler			
61	532174882	Spring Ext Elect Clutch 42" Dck			

NOTE: All component dimensions given in U.S. inches
1 inch = 25.4 mm