

# GTH 2548 XP A

954567895

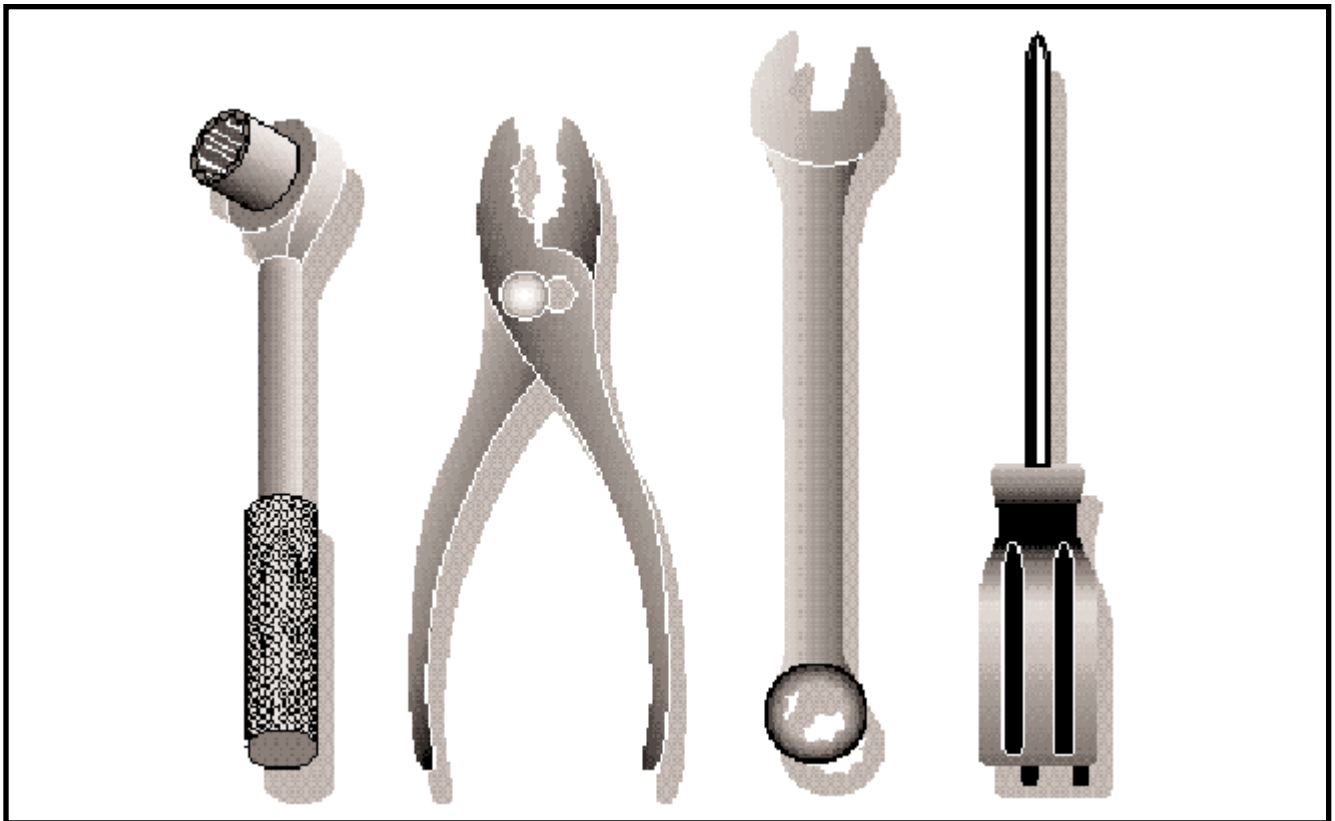

Repair Parts Manual

Ride Mower

# TRACTOR - - MODEL NO. GTH2548XPA

## SCHEMATIC

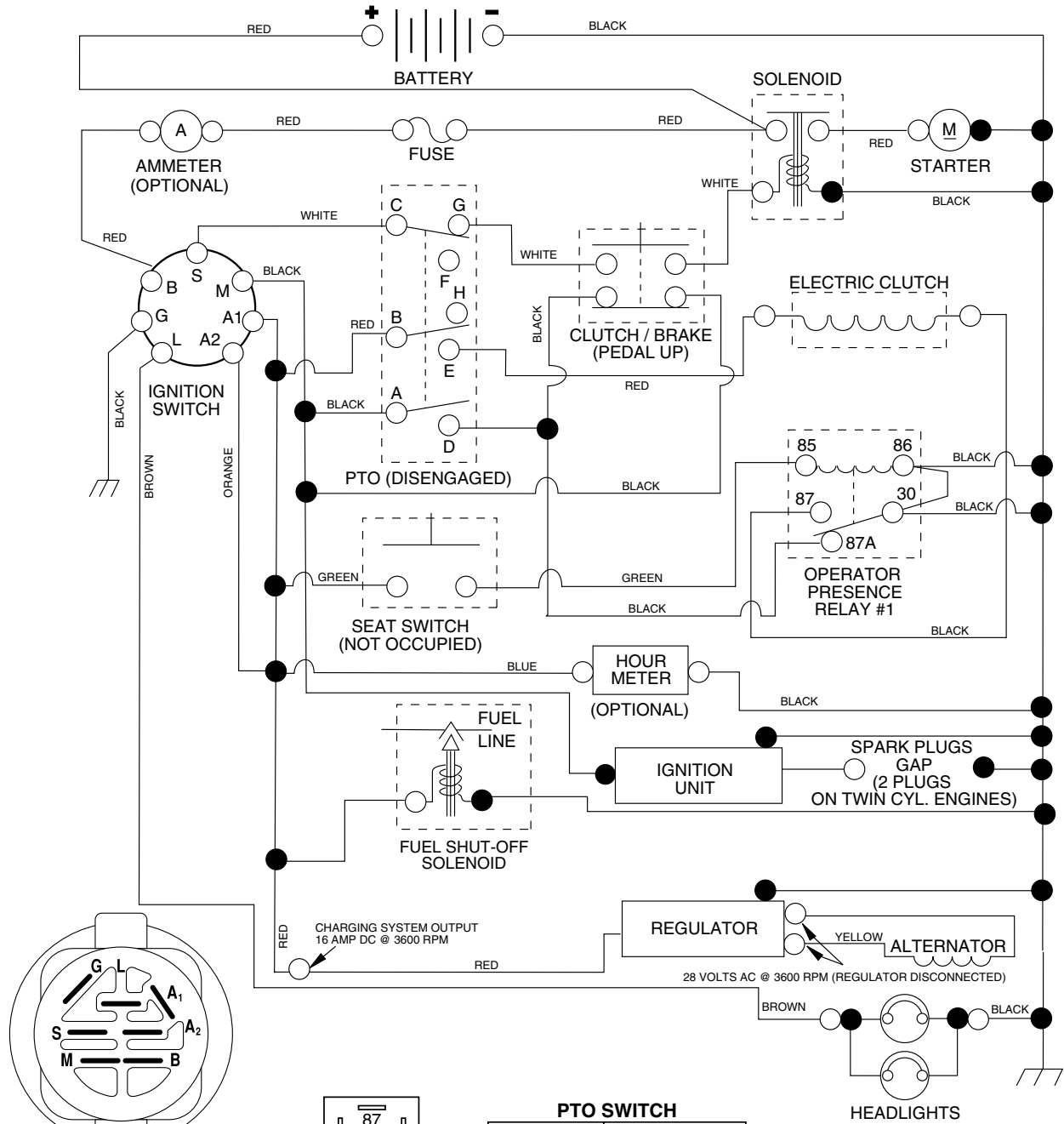

**IGNITION SWITCH**

POSITION	CIRCUIT	"MAKE"
OFF	M + G + A1	NONE
ON + LIGHTS	B + A1	L + A2
ON	B + A1	NONE
START	B + S + A1	NONE

**WIRING INSULATED CLIPS**  
**NOTE:** IF WIRING INSULATED CLIPS WERE REMOVED FOR SERVICING OF UNIT, THEY SHOULD BE REPLACED TO PROPERLY SECURE YOUR WIRING.

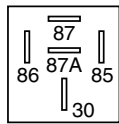

**RELAY**



**PTO SWITCH**

POSITION	CIRCUIT
OFF	C + G, B + H
ON	C + F, B + E, A + D

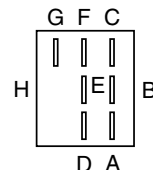

# REPAIR PARTS

## TRACTOR - - MODEL NO. GTH2548XPA

### ELECTRICAL

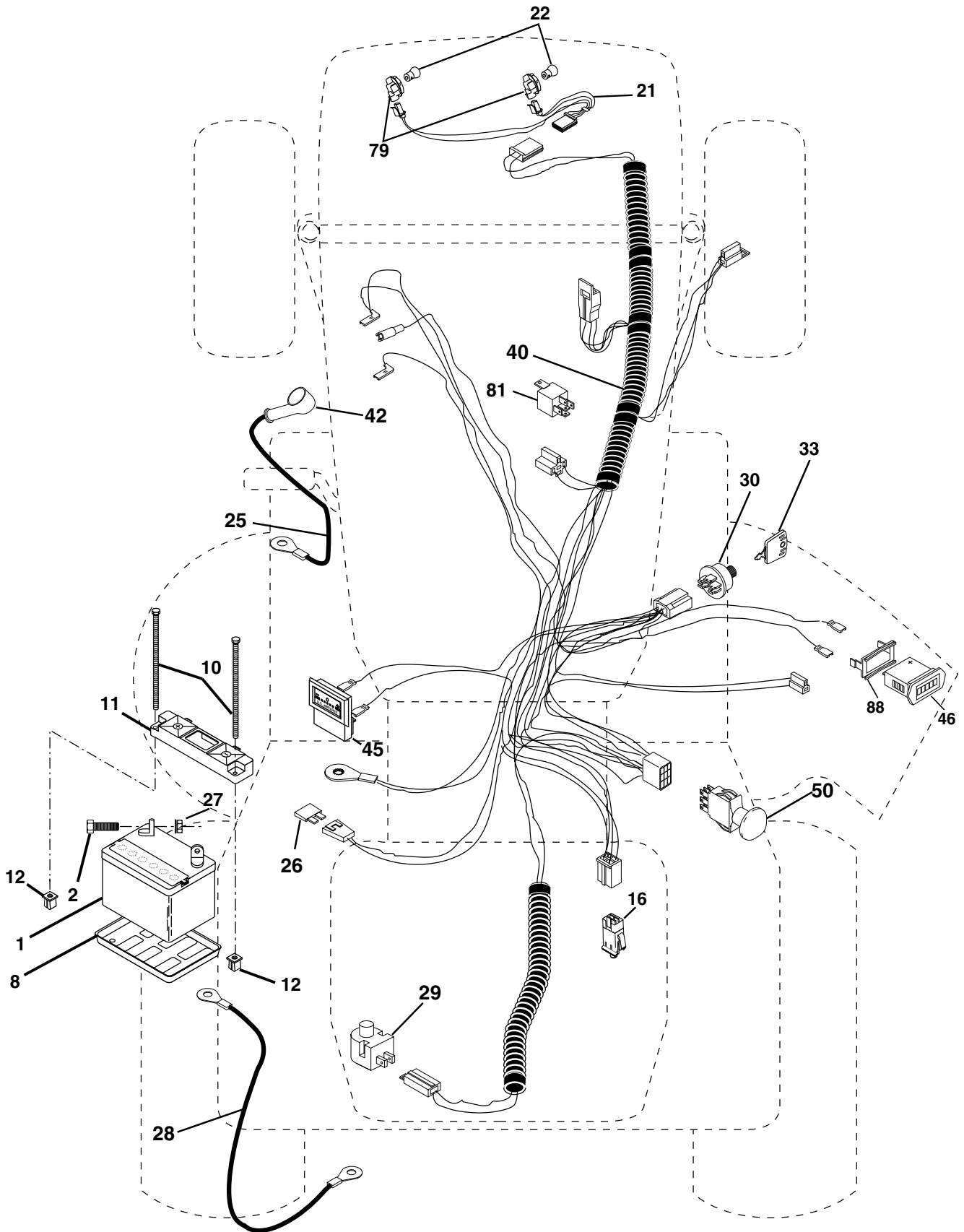

# REPAIR PARTS

## TRACTOR - - MODEL NO. GTH2548XPA

### ELECTRICAL

KEY NO.	PART NO.	DESCRIPTION
1	532 14 49-27	Battery
2	874 76 04-12	Bolt Hex Head 1/4-20 x 3/4
8	532 12 48-86	Tray, Battery
10	532 14 52-11	Bolt, Battery Front 1/4-20 x 7.5 Zinc
11	532 15 01-09	Holddown Battery Front Mount
12	532 14 57-69	Nut, Push Nylon 1.4" Battery Front
16	532 17 61-38	Switch Interlock
21	<b>532 17 56-88</b>	Harness Socket Light w/4152J
22	<b>532 00 41-52</b>	Bulb Light
25	532 17 76-62	Cable, Battery
26	532 10 88-24	Fuse
27	873 51 04-00	Nut Keps Hex 1/4-20
28	532 17 06-97	Cable, Ground
29	532 16 07-84	Switch, Plunger Normal Op Olive
30	532 17 55-66	Switch, Ign
33	532 14 04-01	Key
40	532 17 02-38	Harness Ign.
42	532 15 43-36	Cover, Terminal Red
45	532 12 28-22	Ammeter
46	532 16 96-35	Hourmeter Snap-In
50	532 17 46-51	Switch, PTO
79	<b>532 17 52-42</b>	Bulbholder Asm
81	532 10 97-48	Relay Asm.
89	532 16 96-39	Bracket Snap-In Hourmeter

**NOTE:** All component dimensions given in U.S. inches  
1 inch = 25.4 mm

# REPAIR PARTS

## TRACTOR - - MODEL NO. GTH2548XPA

### CHASSIS AND ENCLOSURES

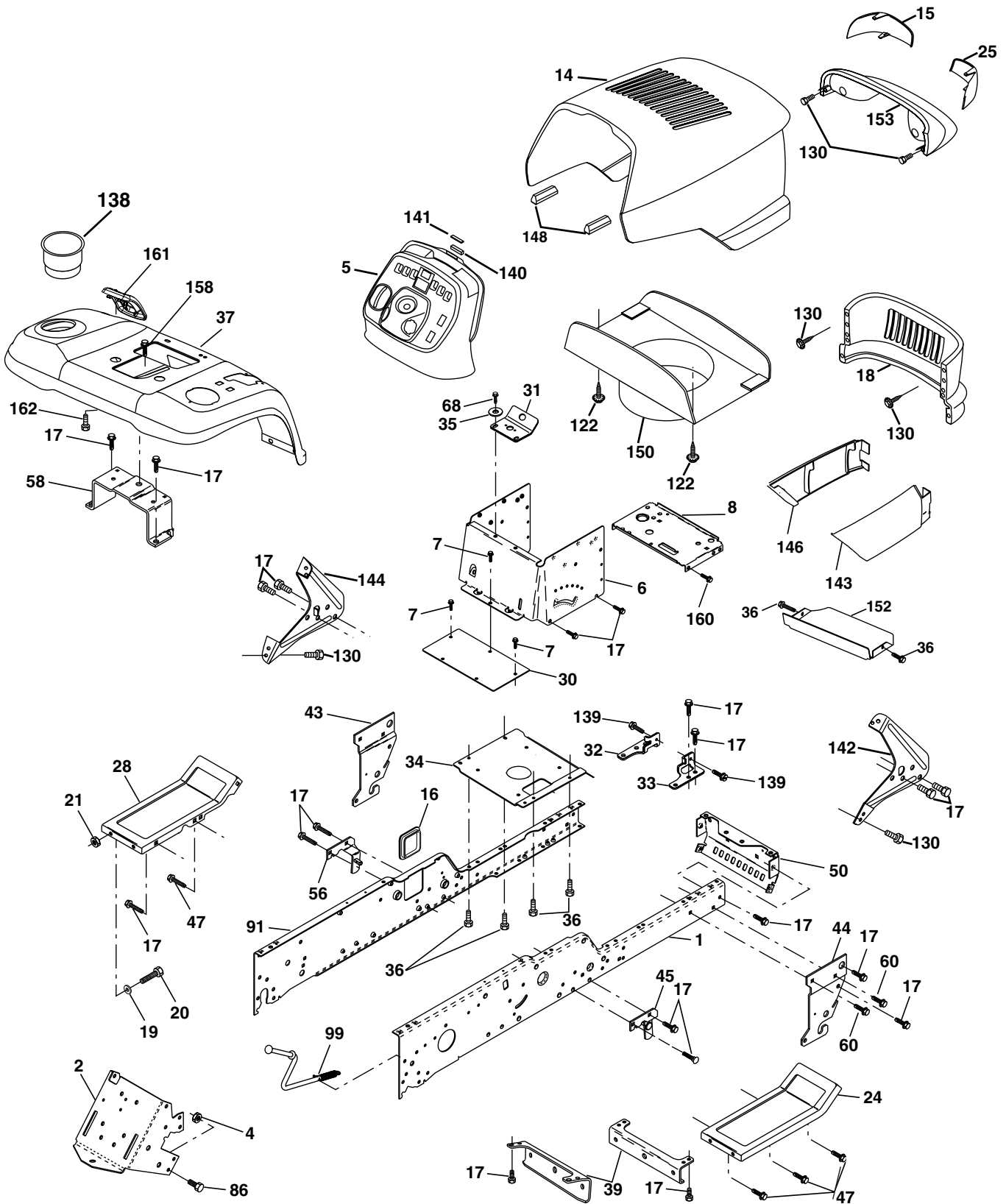

# REPAIR PARTS

## TRACTOR - - MODEL NO. GTH2548XPA

### CHASSIS AND ENCLOSURES

KEY NO.	PART NO.	DESCRIPTION	KEY NO.	PART NO.	DESCRIPTION
1	532 18 03-72	Rail, Frame RH	45	532 17 60-18	Bracket Asm., Susp Chassis Rh
2	532 17 52-82	Drawbar, Gt	47	817 49 06-08	Screw Thdrol 3/8-16 x 1/2
4	873 80 07-00	Nut, Lock Hex 7/16 Unc	50	532 17 54-76	Bracket, Chassis Front
5	532 17 75-82	Dash, Plastic	56	532 17 60-16	Bracket Asm., Susp Chassis Lh
6	532 15 78-82	Dash, 1PCS, Lower	58	532 17 53-15	Bracket Asm., Fender
7	817 72 04-08	Screw, Thd Cut 1/4-20 x 1/2	68	817 49 05-08	Screw, 5/16-18 x 1/2
8	532 14 51-66	Support, Battery	86	874 76 07-16	Bolt, Fin Hex 7/16-14 Unc x 1
14	532 17 75-83	Hood Asm., Pnt	91	532 18 03-66	Rail, Frame Lh
15	532 16 18-41	Lens LH	99	532 17 71-43	Rod Asm. Bypass
16	532 12 17-94	Cover, Access	122	532 16 14-64	Screw Hex WSHD 8-18 x 7/8
17	817 06 06-12	Screw, 3/8-16 x 3/4	130	532 16 48-63	Screw Hw Hd Hi-Lo #13-16 x 3/4
18	532 17 75-84	Grille	138	532 18 17-98	Cupholder
19	819 13 13-12	Washer 13/32 x 13/16 x 12 Ga.	139	532 17 18-73	Bolt Shoulder 5/16-18
20	874 76 06-16	Bolt, Fin Hex 3/8-16 x 1	140	532 16 38-06	Magnet Stealth
21	873 68 06-00	Nut, Crownlock 3/8-16	141	532 16 38-05	Striker Plate
24	532 18 10-58	Footrest, RH	142	532 16 18-97	Bracket Dash Stealth RH
25	532 16 18-42	Lens RH	143	532 17 75-86	Skirt Grille RH
28	532 18 10-57	Footrest, LH	144	532 16 19-00	Bracket Dash Stealth LH
30	532 14 50-52	Saddle	146	532 17 75-87	Skirt Grille LH
31	532 16 14-19	Bracket Supt 1-pc Vgt Steering	148	532 16 46-55	Extrusion Bumper
32	532 16 13-27	Bracket, Frame Pivot Lh	150	532 16 12-37	Duct Heat Hood
33	532 16 13-26	Bracket, Frame Pivot Rh	152	532 17 79-56	Shield, Browning
34	532 17 70-18	Plate Asm Engine Chassis	153	<b>532 17 97-65</b>	Light Box Asm w/Lens
35	819 11 11-16	Washer 11/32 x 11/16 x 16 Ga.	158	817 67 06-08	Screw 3/8-16 x 1/2
36	817 06 05-12	Screw 5/16-18 x 3/4	160	817 06 05-08	Screw 5/16-18 x 1/2
37	532 18 17-20	Fender, Pnt.	161	532 18 17-87	Consol Fuel Window
39	532 17 52-78	Bracket, Axle Front	162	532 14 24-32	Screw Hex Wsh Hi-Lo 1/4-1/2 Unc
43	532 13 69-39	Bracket, Spnsn Front Lh			
44	532 13 69-40	Bracket, Spnsn Front Rh			

**NOTE:** All component dimensions given in U.S. inches  
1 inch = 25.4 mm



# REPAIR PARTS

## TRACTOR - - MODEL NO. GTH2548XPA

### GROUND DRIVE

KEY NO.	PART NO.	DESCRIPTION	KEY NO.	PART NO.	DESCRIPTION
1	-----	Transaxle Hydro Gear 311-3500 (Order Parts From Transaxle Manufacturer)	89	8736807-00	Nut Crownlock 7/16-14 Unc
2	5321806-42	Key Sq. 1/4 x 1/4 x 2	94	5321338-35	Fastener Christmas Tree
3	5320075-63	Washer	98	5321410-04	Bracket Shift
6	8760204-12	Pin, Cotter	106	5321429-18	O-Ring Asm Hydro Gear
7	5321405-07	Wheel, Hub Assembly	107	5321547-39	Line Fuel Hydro 15" VGT
9	5321400-80	Bolt, Hub	108	5321429-17	Cap Asm Vent Hydro Gear
20	8739408-00	Nut	111	5321562-40	Spacer Shift Lever VGTH
22	5321802-35	Lever Asm Shift	112	5321561-04	Washer Nylon High Temp
23	5321408-45	Knob	114	8738005-00	Nut Lock Hex W/Ins 5/16-18 Unc
29	5321766-00	Brake, Rod	117	8739006-00	Nut, Lock Flg. 3/8-16
33	8120000-53	Ring E	120	8170606-12	Screw 3/8-16 x .75
34	5320716-73	Cap, Parking Brake	121	5321756-11	Bracket Strap Torque
35	5321376-48	Rod, Parking Brake	122	8720105-20	Bolt RDHDSQ 5/16-18 Unc x 2-1/2
36	5321494-12	Spring, Drive Ground	123	5321766-02	Rod Shift
37	5321217-49	Washer 25/32 x 1-1/4 x 16 Ga.	124	5321654-92	Bolt Shoulder 5/16-18 x .561
38	5321500-35	Nyliner	125	5321668-80	Screw 5/16-18 x 5/8
39	8743210-16	Screw, Fin. #10-24 x 1	126	5321660-02	Washer SRRTD 5/16 ID x 1.0 x .125
40	5321785-75	Actuator, Interlock VGT	127	5321773-62	Link Control Clutch
41	8739310-00	Nut Centerlock 10-24 Unc	128	5321766-24	Spring Drive GRND
42	5321247-82	Cover, Pedal	129	5321794-73	Bracket Asm Idler Tensioning
46	5321451-70	Retainer, Spring	130	8191310-16	Washer 13/32 x 5/8 x 16 Ga.
48	8721106-14	Bolt Rdhd 3/8-16 x 1.3/4 Gr. 5	131	8760203-12	Pin Cotter 3/32 x 3/4
50	5321314-94	Pulley, Idler, Flat	132	5321754-67	Bracket Mtg Hydro 3500 LH VGT
52	5321277-83	Pulley, Idler, Grooved	133	5321754-68	Bracket Mtg Hydro 3500 RH VGT
55	5321057-06	Bearing, Idler	135	5321773-64	Link Asm Control Hydro 3500
56	5321615-97	V-Belt	137	5321249-49	Nut Lock 5/16-18 NC Thd.
58	8747607-24	Bolt Fin Hex 7/16-14 x 1-1/2	138	5320013-70	Washer Thrust 5/8 x 1.10 x 1/32
61	5321439-95	Pulley, Transaxle	142	5321754-69	Strap Torque HG-3500
64	5321766-01	Shaft, Brake Pedal	143	8170605-12	Screw Thdrol 5/16-18 x 3/4
65	5321796-13	Bolt, Shoulder	145	5321631-68	Washer Axle Flange HG-3000
68	5320051-42	Pin, Roll	146	5321404-62	Fan 7" Hydro
69	5321238-00	Washer	147	5321413-22	Washer
70	5321817-88	Console Automatic YT/GT	148	8170606-20	Screw 3/8-16 x 1-1/4
73	8744905-48	Bolt Hex Flghd 5/16-18 x 3 Gr5	151	8747605-14	Bolt Hex 5/16-18 x 7/8
74	5321424-32	Screw Hex Wsh. Hi-Lo 1/4-1/2	152	5321787-05	Bolt Hex 5/16 x 1 W/Patch
77	8747607-16	Bolt Fin Hex 7/16-14 x 1	153	5321247-88	Spring, Retainer

**NOTE:** All component dimensions given in U. S. inches 1 inch = 25.4 mm



# REPAIR PARTS

## TRACTOR - - MODEL NO. GTH2548XPA

### STEERING ASSEMBLY

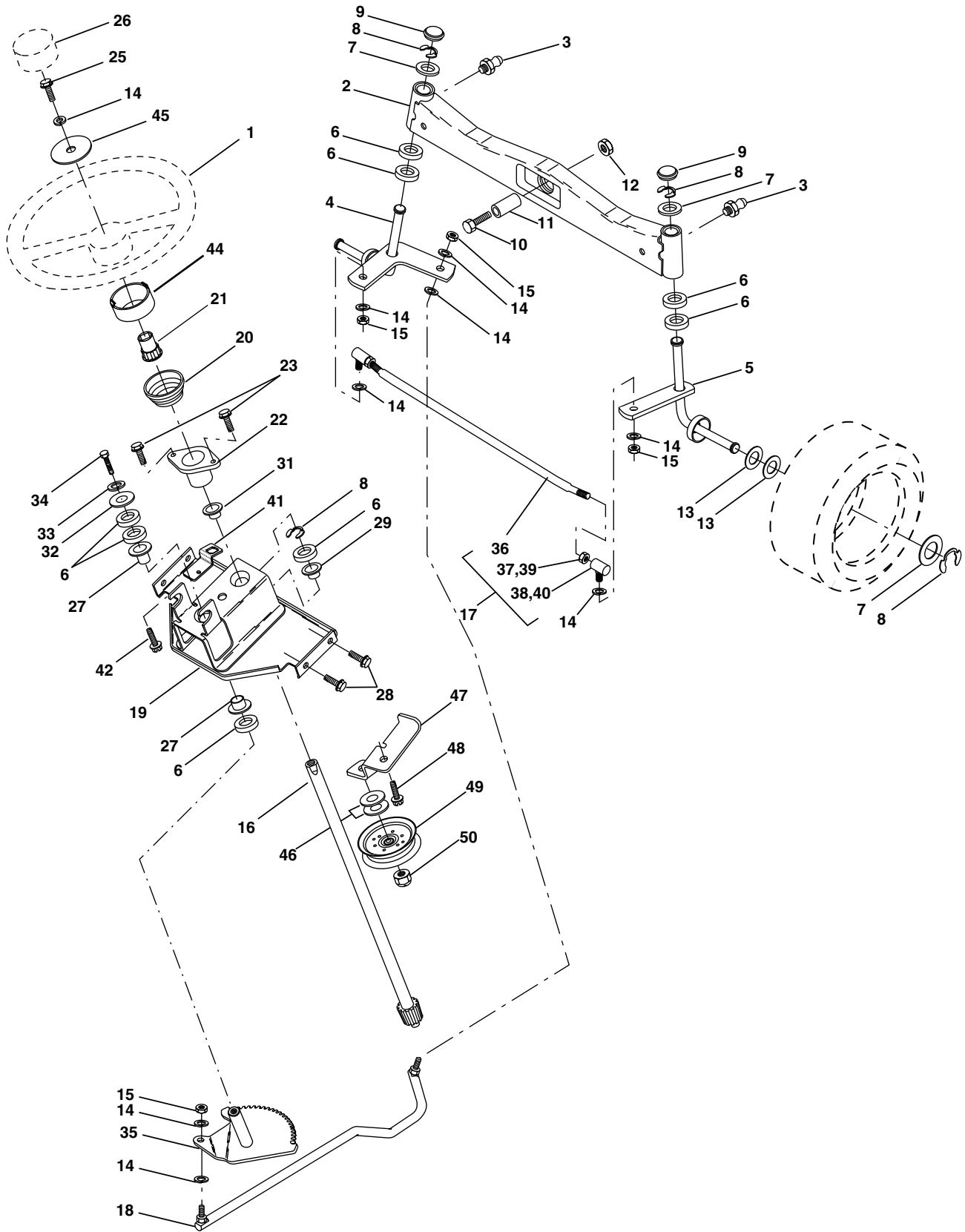

# REPAIR PARTS

## TRACTOR - - MODEL NO. GTH2548XPA

### STEERING ASSEMBLY

KEY NO.	PART NO.	DESCRIPTION
1	532 16 66-27	Wheel, Steering
2	532 17 85-57	Axle Asm., Front
3	532 12 48-36	Fitting, Grease
4	532 16 18-49	Spindle Asm, LH
5	532 16 18-48	Spindle Asm., RH
6	532 12 49-31	Bearing, Race Thrust Harden
7	532 12 17-48	Washer 25/32 x 1-5/8 x 16 Ga.
8	812 00 00-29	Ring, Klip #T5304-75
9	532 12 12-32	Cap, Spindle
10	874 78 10-44	Bolt, Fin Hex 5/8-11 x 2-3/4
11	532 13 65-18	Spacer Brg Axle Front 1.570
12	873 90 10-00	Nut, Lock Flange 5/8-11 Unc
13	532 12 17-49	Washer 25/32 x 1-1/4 x 16 Ga.
14	810 04 06-00	Washer, Lock Hvy Hlcl Spr 3/8
15	532 12 47-01	Nut Lock Center 3/8-24 Unf
16	532 14 51-03	Shaft Asm., Steering
17	532 13 73-47	Rod Asm., Tie Ball J Ball Vgt (Inc. Key No. 36-40)
18	532 17 55-72	Draglink, Ball Joint Solid Vgt
19	532 15 60-11	Support Asm., Steering Vgt
20	532 17 75-92	Boot Steering
21	532 15 99-45	Adapter, Wheel Steering
22	532 15 51-05	Bushing, Strg.
23	532 15 29-27	Screw
25	874 78 06-16	Bolt, Fin Hex 3/8-16 x 1 Gr. 5
26	532 16 66-26	Cap , Wheel Steering
27	532 12 49-37	Bearing, Col. Strg.
28	817 00 06-12	Screw 3/8-16 x 3/4
29	532 10 42-39	Bearing, Flange
31	532 13 81-36	Bushing, Nyliner Snap
32	819 11 16-10	Washer 11/32 x 1 x 10 Ga.
33	810 04 05-00	Washer, Lock Hvy Hlcl Spr 5/16
34	874 78 05-12	Bolt, Hex Hd 5/16-18 x 3/4
35	532 13 80-59	Gear, Sector Steering
36	532 13 71-56	Tie Rod
37	873 36 06-00	Jam Nut RH Thread
38	532 10 98-50	Joint Asm. Ball RH Thread
39	873 70 06-00	Nut Hex Jam 3/8-24 UNF LH
40	532 10 98-51	Joint Asm Ball LH
41	532 15 52-46	Bracket Switch Inerlock VGT97
42	817 49 05-08	Screw 5/16-18 x 1/2
44	532 17 75-93	Extension Steering Premium
45	819 13 24-11	Washer 13/32 x 1-1/20 x 11 Ga.
46	819 13 16-10	Washer FLat 13/32 x 1/10 Ga.
47	532 17 78-63	Bracket Asm. Idler
48	817 06 06-12	Screw 3/8-16 x .75
49	532 17 58-20	Pulley Idler Flat
50	873 90 06-00	Nut Lock Flg 3/8-16 Unc

**NOTE:** All component dimensions given in U.S. inches  
1 inch = 25.4 mm

# REPAIR PARTS

## TRACTOR - - MODEL NO. GTH2548XPA

### ENGINE

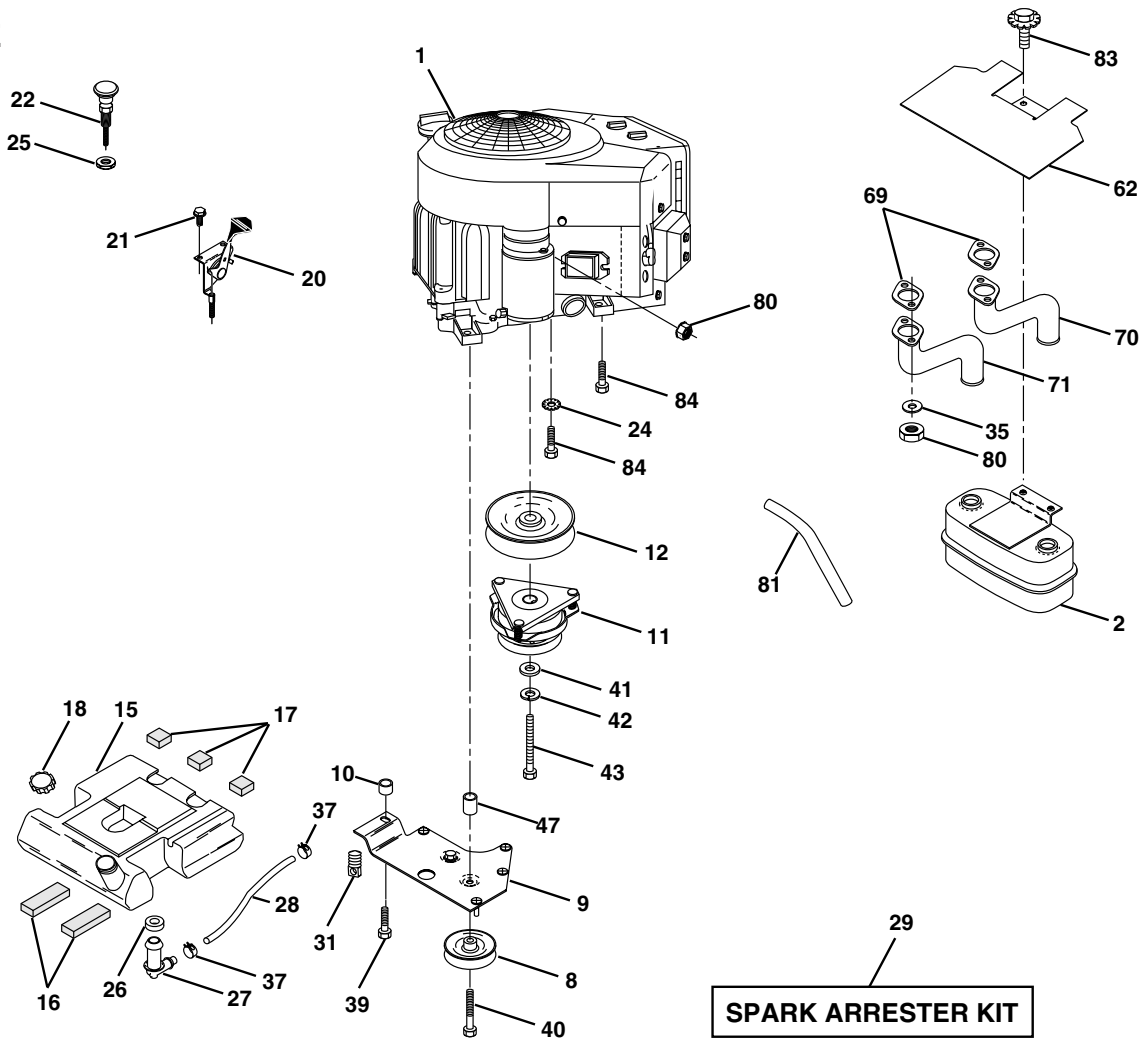

KEY NO.	PART NO.	DESCRIPTION
1	----	Engine Kawasaki, Model No. FH721V (Order parts from engine manufacturer)
2	532 14 97-23	Muffler Side
8	532 12 13-61	Pulley V-Idler
9	532 17 77-48	Keeper Asm. Belt Engine VGT
10	532 17 52-87	Bushing
11	532 17 46-05	Clutch Electric
12	532 14 39-96	Pulley Engine VGT Elect Clutch
15	532 17 91-15	Tank Fuel
16	532 10 92-27	Pad Spacer
17	532 10 60-82	Pad Spacer
18	532 18 18-03	Cap Fuel
20	532 17 81-47	Control Throttle
21	532 16 48-63	Screw Hex Thd Cut 1/4 - 20 X 5/8
22	532 17 81-48	Control Choke
24	811 05 06-00	Washer Ext Tooth 3/8
25	873 92 06-00	Nut Keps 3/8-24 Unf
26	532 12 49-52	Bushing
27	532 13 92-77	Stem Tank Fuel
28	532 12 47-03	Fuel Line

KEY NO.	PART NO.	DESCRIPTION
29	532 13 71-80	Spark Arrester Kit
31	532 14 50-06	Clip Push-In Hinged
35	810 01 05-00	Washer
37	532 12 34-87	Clamp Hose
39	817 49 06-36	Screw TT 3/8-16 x 2-1/4 UNC
40	817 49 06-64	Screw TT 3/8-16 x 4 UNC
41	532 12 61-97	Washer 1-1/2 OD X 15/32 ID X .250
42	810 04 07-00	Washer Lock 7/16
43	532 17 99-53	Bolt Hex 7/16-20 X 3.75 Gr. 5
47	532 17 52-88	Bushing
62	532 17 62-52	Shield Heat Muffler
69	----	Gasket (Order from engine mfg.)
70	532 17 57-66	Tube Exhaust LH
71	532 17 57-67	Tube Exhaust RH
80	532 16 33-05	Nut Flange M8-1.25
81	532 14 84-56	Tube Drain Oil Easy
83	532 17 18-77	Bolt 5/16-18unc X 1-3/4 W/Sems
84	817 06 06-24	Screw 3/8-16 x 1-1/2

**NOTE:** All component dimensions given in U.S. inches  
1 inch = 25.4 mm

# REPAIR PARTS

## TRACTOR - - MODEL NO. GTH2548XPA

### SEAT ASSEMBLY

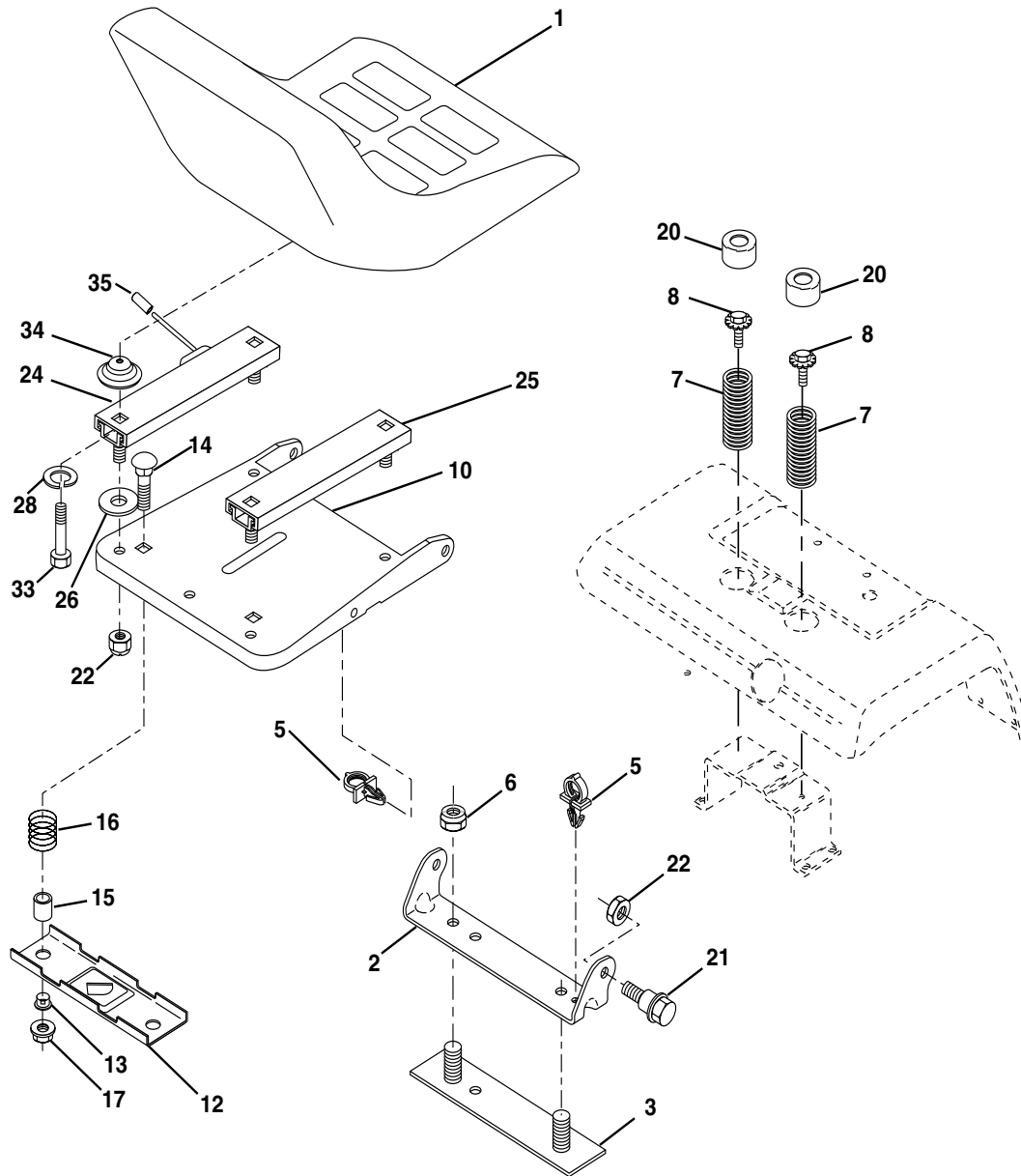

KEY NO.	PART NO.	DESCRIPTION
1	532 12 41-87	Seat
2	532 14 05-51	Bracket, Pivot Seat
3	532 14 06-75	Strap, Fender
5	532 14 50-06	Clip, Push In Hinged
6	873 80 06-00	Nut, Crownlock 3/8-16
7	532 12 41-81	Spring, Seat Cprsn
8	532 17 18-77	Bolt 5/16-18 UNC X 3/4
10	532 17 48-94	Pan, Seat
12	532 12 12-46	Bracket, Mounting Switch
13	532 12 12-48	Bushing, Snap
14	872 05 04-12	Bolt, Carriage 1/4-20 X 1-1/2
15	532 12 12-49	Spacer, Split
16	532 12 37-40	Spring, Cprsn

KEY NO.	PART NO.	DESCRIPTION
17	532 12 39-76	Nut, Lock 1/4 Lge Flg Gr. 5
20	532 12 42-38	Cap, Spring Seat
21	532 17 18-52	Bolt, Shoulder 5/16-18
22	873 80 05-00	Nut, Crownlock 5/16-18
24	532 17 79-46	Track Slide Seat LH Locking
25	532 17 79-47	Track Slide Seat RH Free
26	819 11 10-12	Washer 11/32 x 5/8 x 12 Ga.
28	810 01 05-00	Washer Split
33	874 78 05-16	Bolt Fin Hex 5/16-18 x 1
34	532 12 44-27	Spacer
35	532 17 84-26	Cap Vinyl

**NOTE:** All component dimensions given in U.S. inches  
1 inch = 25.4 mm

# REPAIR PARTS

## TRACTOR - - MODEL NO. GTH2548XPA

### DECALS

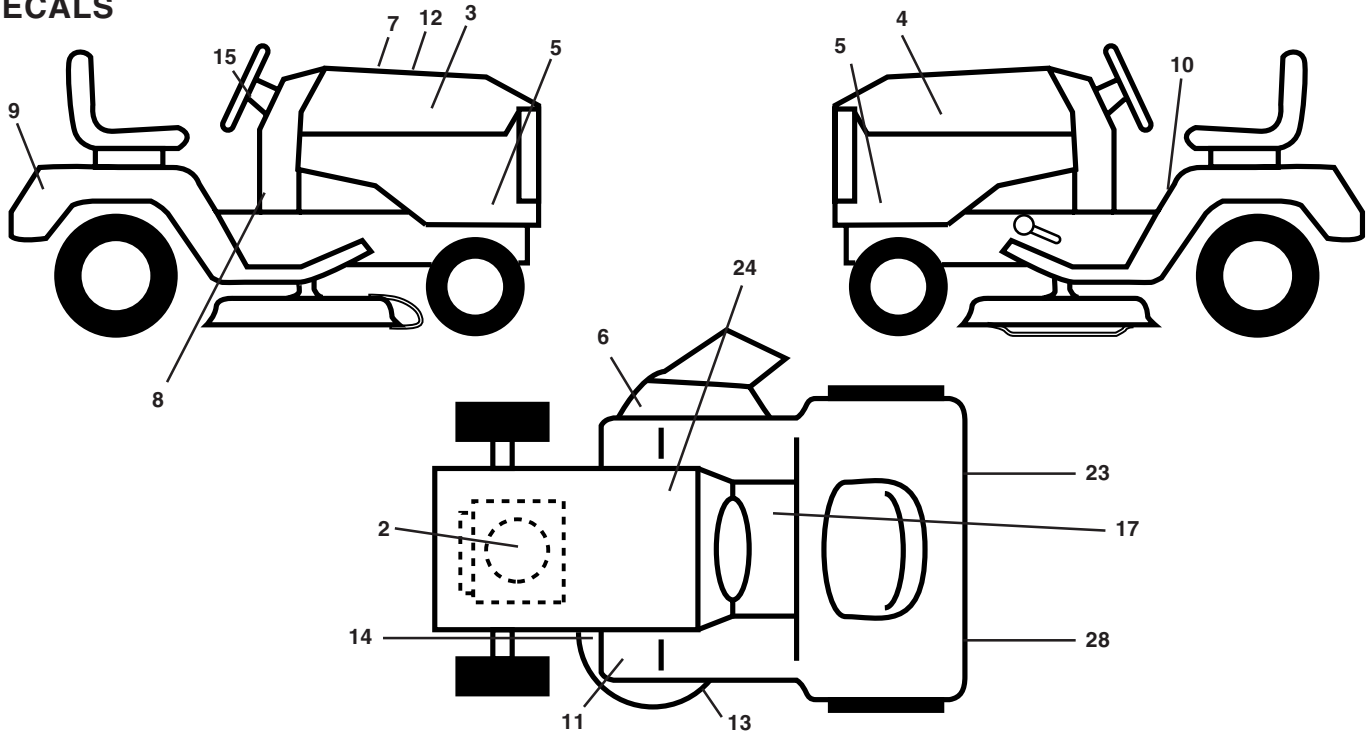

KEY NO.	PART NO.	DESCRIPTION
2	532 18 00-95	Decal, Engine
3	532 18 16-60	Decal, Hood, RH
4	532 18 16-61	Decal, Hood, LH
5	532 18 00-91	Decal, Side Panel
6	532 17 05-63	Decal, Warning
7	532 18 90-41	Decal, Customer Resp.
8	532 17 68-64	Decal, Dash
9	532 17 68-22	Decal, Fender
10	532 15 71-40	Decal, Danger
11	532 18 12-53	Decal, Foot Rest

KEY NO.	PART NO.	DESCRIPTION
12	532 18 10-66	Decal, Final
13	532 17 52-91	Decal, V-Belt Sch
14	532 17 85-02	Decal, Caution
15	532 17 05-64	Decal, Ins. Strg Whl
17	532 14 08-37	Decal, Saddle Brake Parking
23	532 17 49-70	Reflector, Taillight RH
24	532 14 50-05	Decal, Btry Dngr/Psn
27	532 16 69-60	Decal, Drawbar
28	532 17 49-69	Reflector, Taillight LH
--	532 13 83-11	Decal, Handle Lift (Lift Handle)
--	532 18 13-96	Manual, Owner's (English)
--	532 18 13-97	Manual, Owner's (French)

### WHEELS & TIRES

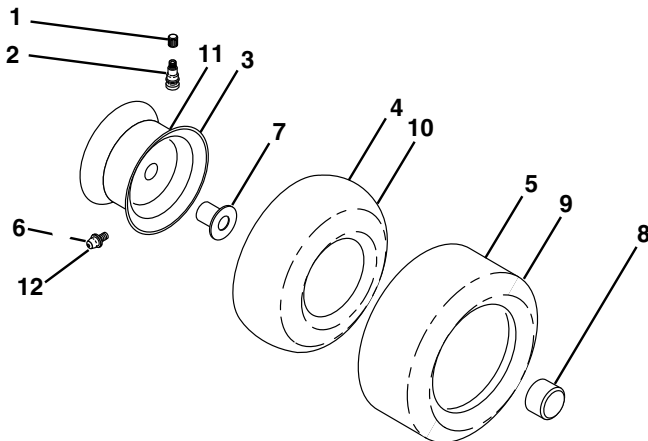

KEY NO.	PART NO.	DESCRIPTION
1	532 05 91-92	Cap, Valve, Tire
2	532 06 51-39	Stem, Valve
3	532 18 18-39	Rim Assembly, Front
4	532 00 81-34	Tube, Front (Service Item Only)
5	532 14 87-41	Tire, Front
6	532 12 49-57	Fitting, Grease
7	532 12 49-59	Bearing, Flange (Front Wheel Only)
8	532 17 50-39	Cap, Hub
9	532 15 16-07	Tire, Rear
10	532 00 71-54	Tube, Rear (Service Item Only)
11	532 18 18-40	Rim Assembly, Rear
12	532 12 48-60	Fitting, Grease
--	532 14 43-34	Sealant, Tire (10 oz. Tube)

**NOTE:** All component dimensions given in U.S. inches  
1 inch = 25.4 mm

# REPAIR PARTS

## TRACTOR - - MODEL NO. GTH2548XPA

### LIFT ASSEMBLY

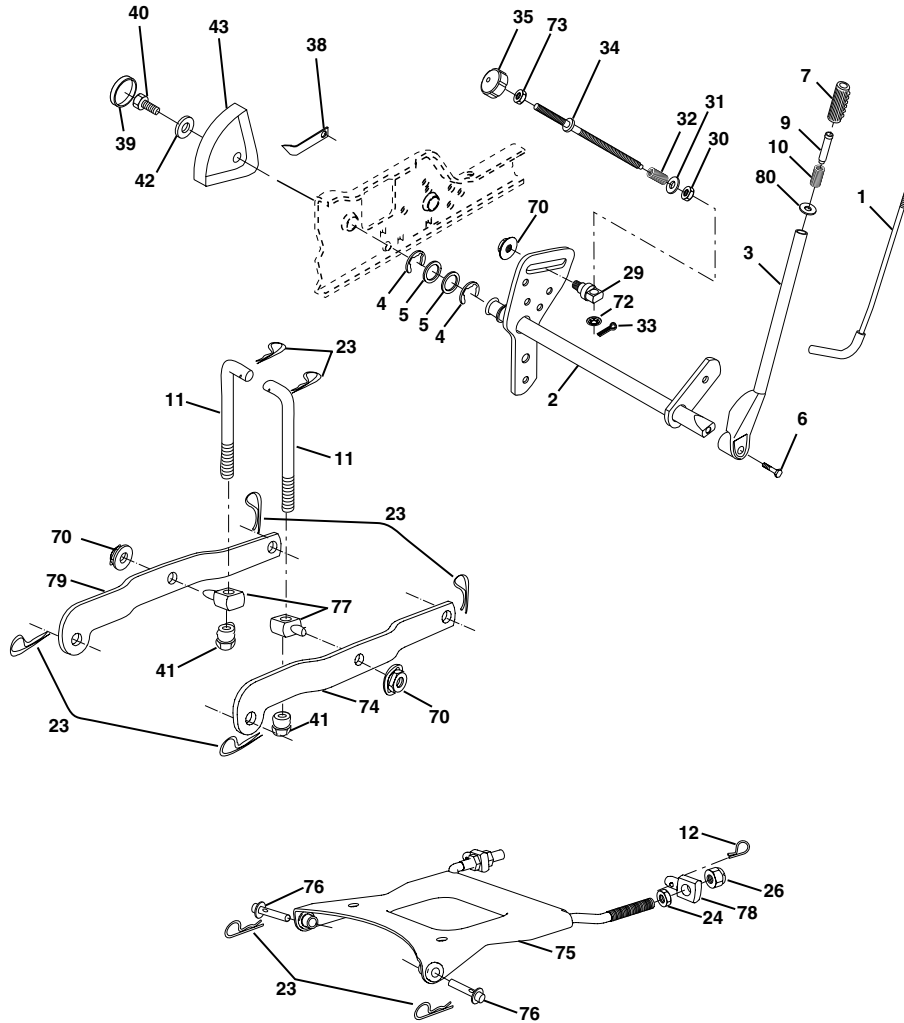

KEY NO.	PART NO.	DESCRIPTION
1	532 12 10-06	Rod Asm., Lever
2	532 18 00-45	Shaft Asm., Lift Vgt
3	532 15 91-89	Lever Asm., Lift Rh
4	812 00 00-22	E-Ring Truarc #5133-87
5	819 29 20-16	Washer 29/32 x 1-1/4 x 16 Ga.
6	871 11 06-24	Bolt, Fin Hex 3/8-16 x 1-1/2
7	532 12 56-31	Grip, Handle
8	532 12 45-26	Button, Plunger
9	532 12 23-64	Plunger, Lever Lift
10	532 12 48-74	Spring 2-1/8"
11	532 17 53-75	Link Lift
12	532 16 35-52	Retainer, Spring
14	532 16 98-65	Bearing
23	532 12 46-70	Retainer, Spring
24	873 35 08-00	Nut, Jam Hex 1/2-13 Unc
26	873 80 08-00	Nut, Lock W/Wsh 1/2-13 Unc
29	532 15 02-33	Trunion Infin Height
30	532 11 08-07	Nut, Special
31	819 13 10-16	Washer 13/32 x 5/8 x 16 Ga.
32	532 13 71-50	Spring, Compression Inf Hgt
33	876 02 03-08	Pin, Cotter 3/32 x 1/2
34	532 13 71-67	Rod, Adj Lift
35	532 13 80-57	Knob, Inf 3/8-16 Unc

KEY NO.	PART NO.	DESCRIPTION
38	532 15 50-97	Pointer Height Indicator
39	532 12 39-35	Plug, Hole Blk. 1.485/1.515 Dia.
40	817 06 05-16	Screw 5/16-18 x 1
41	532 17 59-94	Nut, Lift Link 7/16-20
42	819 11 24-10	Washer 11/32 x 1-1/2 x 10 Ga.
43	532 12 39-34	Scale, Indicator Height
70	532 14 52-12	Nut Hex Flange Lock
72	532 11 04-52	Nut Push Phos & Oil
73	873 35 06-00	Nut, Hex Jam 3/8-16 Unc
74	532 17 58-02	Arm Suspension Rear RH
75	532 17 58-05	Plate, Asm, Susp, Front
76	532 17 55-60	Pin Flange
77	532 17 62-05	Trunion Susp Arm
78	532 17 56-89	Trunion, Front, Susp
79	532 17 53-78	Arm, Suspension LH
80	532 12 66-84	Washer 1/4 x 5/8 x .062

**NOTE:** All component dimensions given in U.S. inches  
1 inch = 25.4 mm

# REPAIR PARTS

## TRACTOR - - MODEL NO. GTH2548XPA

### MOWER DECK

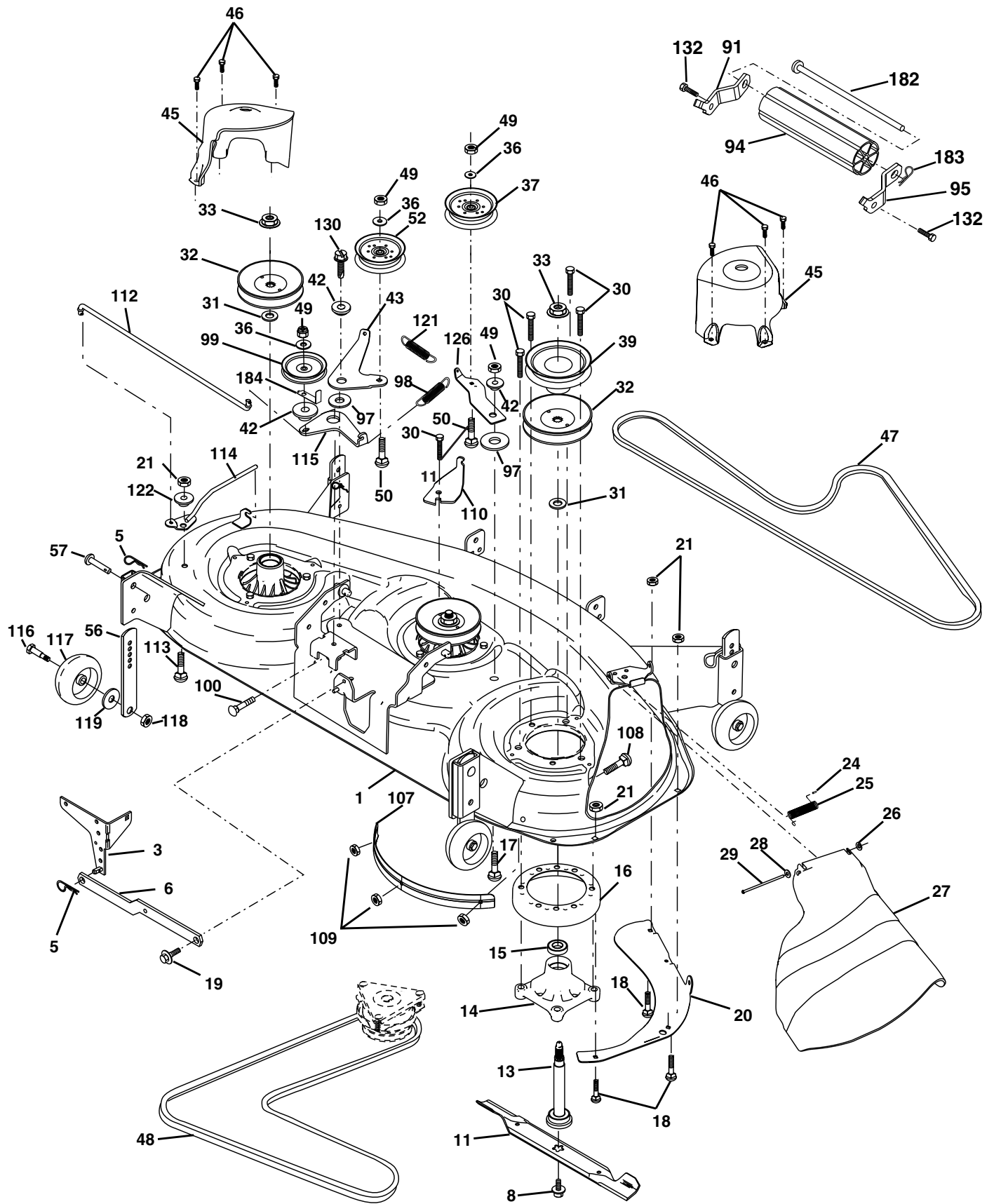



# REPAIR PARTS

## TRACTOR - - MODEL NO. GTH2548XPA

### MOWER DECK

KEY NO.	PART NO.	DESCRIPTION	KEY NO.	PART NO.	DESCRIPTION
1	532 18 03-58	Deck Weldment Mower 48	56	532 15 59-86	Bar Pnt Adj.
3	532 17 89-15	Bracket Asm., Sway Bar	57	532 15 69-41	Pin Head Rivet
5	532 12 46-70	Retainer Spring	90	874 76 05-16	Bolt Hex HD 5/16-18 x 1
6	532 17 80-24	Bar Sway Deck	91	532 18 05-34	Bracket N Roller LH
8	532 17 43-65	Bolt 7/16 Asm. Blade	93	819 17 14-16	Washer 17/32 x7/8 x 16 Ga
11	532 18 00-54	Blade	94	532 17 60-66	Roller Nose 48"
13	532 17 43-60	Shaft Asm. w/Lower Bearing	95	532 18 05-35	Bracket Asm N Roller RH
14	532 17 43-58	Mandrel Asm.	97	532 13 39-43	Washer Hardened
15	532 11 04-85	Bearing, Ball, Mandrel	98	532 17 94-79	Spring Primary Drive
16	532 17 44-93	Stripper Mandrel Deck	99	532 17 50-80	Pulley Idler"V"
17	872 11 06-10	Bolt RDHD Sq Neck 3/8-16 x 1.25	100	872 11 06-16	Bolt RDHD Sqnk 3/8-16 UNC x 2
18	872 14 05-05	Bolt, Carriage 5/16-18 x 5/8	107	532 17 52-94	Baffle Vac Edge Mower
19	532 13 28-27	Bolt, Hex Hd, Shoulder 5/16-18	108	872 14 04-04	Bolt Carr.
20	532 17 43-78	Baffle, Vortex Mower	109	873 68 04-00	Nut Crownlock 1/4-20
21	873 68 05-00	Nut, Crownlock 5/16-18 UNC	110	532 17 50-16	Arm Spring Secondary
24	532 10 53-04	Cap, Sleeve	112	532 17 43-87	Link Tension Relief Lever
25	532 17 81-02	Spring, Torsion	113	872 11 05-08	Bolt Carr. 5/16-18 x 1
26	532 11 04-52	Nut, Push	114	532 17 43-84	Tension Asm. Relief Lever
27	532 18 17-07	Deflector Shield	115	532 17 46-09	Arm Spring Tension Relief
28	819 11 10-16	Washer 11/32 x 5/8 x 16 Ga.	116	532 13 76-44	Bolt, Shoulder
29	532 13 14-91	Rod, Hinge	117	532 13 39-57	Gauge Wheel
30	532 17 39-84	Screw, Thdroll Washer Head	118	873 93 06-00	Nut, Centerlock 3/8-16 UNC
31	532 12 99-63	Washer, Spacer Mower Vented	119	819 12 14-14	Washer 3/8 x 7/8 x 14 Ga.
32	532 17 78-65	Pulley, Mandrel	121	532 17 43-71	Spring Secondary Drive
33	532 17 83-42	Nut, Flg. Top Lock Cntr. 9/16	122	532 17 46-06	Bushing Pivot Tension Relief
36	819 13 13-16	Washer 13/32 x 13/16 x 16 Ga.	126	532 17 43-72	Arm, Idler, Primary Deck
37	532 17 79-68	Pulley, Idler, Flat	130	817 00 06-16	Screw 3/8-16 x 1.0
39	532 17 43-75	Pulley, Idler, Driven	132	817 06 06-12	Screw 3/8-16 x .75
42	532 12 20-52	Spacer, Retainer	182	532 17 91-27	Rod Roller Nose Narrow
43	532 17 43-73	Arm, Idler Secondary	183	532 16 35-52	Retainer Spring
45	532 17 43-43	Cover, Mandrel Deck	184	532 17 39-79	Keeper Belt Idler
46	532 13 77-29	Screw, Thdroll. 1/4-20 x 5/8	--	532 18 15-91	Replacement Mower, Complete
47	532 17 43-69	V-Belt, Mower, Secondary	--	532 17 43-56	Mandrel Asm. Service (Includes Key Nos. 13-15 and 33)
48	532 17 43-68	V-Belt, Mower, Primary			
49	873 68 06-00	Nut, Crownlock 3/8-16 UNC			
50	872 11 06-12	Bolt, Carr. 3/8-16 x 1-1/2 Gr. 5			
52	532 17 58-20	Pulley Idler Flat			

**NOTE:** All component dimensions given in U.S. inches  
1 inch = 25.4 mm