

OWNER'S MANUAL

Model No. CG46A

46 Inch Mower

Grass Catcher

- **Assembly**
- **Operation**
- **Customer Responsibilities**
- **Service and Adjustments**
- **Repair Parts**



SAFETY RULES



Safe Operation Practices for Ride-On Mowers

IMPORTANT: THIS CUTTING MACHINE IS CAPABLE OF AMPUTATING HANDS AND FEET AND THROWING OBJECTS. FAILURE TO OBSERVE THE FOLLOWING SAFETY INSTRUCTIONS COULD RESULT IN SERIOUS INJURY OR DEATH.

I. GENERAL OPERATION

- Read, understand, and follow all instructions in the manual and on the machine before starting.
- Only allow responsible adults, who are familiar with the instructions, to operate the machine.
- Clear the area of objects such as rocks, toys, wire, etc., which could be picked up and thrown by the blade.
- Be sure the area is clear of other people before mowing. Stop machine if anyone enters the area.
- Never carry passengers.
- Do not mow in reverse unless absolutely necessary. Always look down and behind before and while backing.
- Be aware of the mower discharge direction and do not point it at anyone. Do not operate the mower without either the entire grass catcher or the guard in place.
- Slow down before turning.
- Never leave a running machine unattended. Always turn off blades, set parking brake, stop engine, and remove keys before dismounting.
- Turn off blades when not mowing.
- Stop engine before removing grass catcher or unclogging chute.
- Mow only in daylight or good artificial light.
- Do not operate the machine while under the influence of alcohol or drugs.
- Watch for traffic when operating near or crossing roadways.
- Use extra care when loading or unloading the machine into a trailer or truck.

II. SLOPE OPERATION

Slopes are a major factor related to loss-of-control and tipover accidents, which can result in severe injury or death. All slopes require extra caution. If you cannot back up the slope or if you feel uneasy on it, do not mow it.

DO:

- Mow up and down slopes, not across.
- Remove obstacles such as rocks, tree limbs, etc.
- Watch for holes, ruts, or bumps. Uneven terrain could overturn the machine. *Tall grass can hide obstacles.*
- Use slow speed. Choose a low gear so that you will not have to stop or shift while on the slope.
- Follow the manufacturer's recommendations for wheel weights or counterweights to improve stability.
- Use extra care with grass catchers or other attachments. These can change the stability of the machine.
- Keep all movement on the slopes *slow* and *gradual*. Do not make sudden changes in speed or direction.
- Avoid starting or stopping on a slope. If tires lose traction, disengage the blades and proceed slowly *straight* down the slope.

DO NOT:

- *Do not* turn on slopes unless necessary, and then, turn slowly and gradually downhill, if possible.
- *Do not* mow near drop-offs, ditches, or embankments. The mower could suddenly turn over if a wheel is over the edge of a cliff or ditch, or if an edge caves in.
- *Do not* mow on wet grass. Reduced traction could cause sliding.
- *Do not* try to stabilize the machine by putting your foot on the ground.
- *Do not* use grass catcher on steep slopes.

III. CHILDREN

Tragic accidents can occur if the operator is not alert to the presence of children. Children are often attracted to the machine and the mowing activity. *Never* assume that children will remain where you last saw them.

- Keep children out of the mowing area and under the watchful care of another responsible adult.
- Be alert and turn machine off if children enter the area.
- Before and when backing, look behind and *down* for small children.
- Never carry children. They may fall off and be seriously injured or interfere with the safe machine operation.
- Never allow children to operate the machine.
- Use extra care when approaching blind corners, shrubs, trees, or other objects that may obscure vision.

IV. SERVICE

- Use extra care in handling gasoline and other fuels. They are flammable and vapors are explosive.
 - Use only an approved container.
 - Never remove gas cap or add fuel with the engine running. Allow engine to cool before refueling. Do not smoke.
 - Never refuel the machine indoors.
 - Never store the machine or fuel container inside where there is an open flame, such as a water heater.
- Never run a machine inside a closed area.
- Keep nuts and bolts, especially blade attachment bolts, tight and keep equipment in good condition.
- Never tamper with safety devices. Check their proper operation regularly.
- Keep machine free of grass, leaves, or other debris build-up. Clean oil or fuel spillage. Allow machine to cool before storing.
- Stop and inspect the equipment if you strike an object. Repair, if necessary, before restarting.
- Never make adjustments or repairs with the engine running.
- Grass catcher components are subject to wear, damage, and deterioration, which could expose moving parts or allow objects to be thrown. Frequently check components and replace with manufacturer's recommended parts, when necessary.
- Mower blades are sharp and can cut. Wrap the blade(s) or wear gloves, and use extra caution when servicing them.
- Check brake operation frequently. Adjust and service as required.



Look for this symbol to point out important safety precautions. It means CAUTION!!! BECOME ALERT!!! YOUR SAFETY IS INVOLVED.



CAUTION: Always disconnect spark plug wire and place wire where it cannot contact spark plug in order to prevent accidental starting when setting up, transporting, adjusting or making repairs.

CONGRATULATIONS on your purchase of a Grass Catcher. It has been designed, engineered and manufactured to give you the best possible dependability and performance.

Should you experience any problems you cannot easily remedy, please contact your nearest authorized service center. They have competent, well trained technicians and the proper tools to service or repair this unit.

Please read and retain this manual. The instructions will enable you to assemble and maintain your Grass Catcher properly. Always observe the "SAFETY RULES".

NOTE: To make debris disposal easier 30 gallon plastic trash bags may be inserted in plastic grass containers. To order, see repair parts section of this manual.

TABLE OF CONTENTS

SAFETY RULES	2	CUSTOMER RESPONSIBILITIES	12
BAG OF PARTS	4-5	STORAGE	12
ASSEMBLY.....	6-10	REPAIR PARTS	center of manual
OPERATION	11		

Know Your Grass Catcher

READ THIS OWNER'S MANUAL AND SAFETY RULES BEFORE ASSEMBLING OR OPERATING YOUR GRASS CATCHER. Compare the illustrations with the carton contents to familiarize yourself with the parts before starting the assembly. Study the operating instructions and safety precautions thoroughly to insure proper functioning of your Grass Catcher and to prevent injury to yourself and others. Save this manual for future reference.



The operation of any tractor can result in foreign objects thrown into the eyes, which can result in severe eye damage. Always wear safety glasses or eye shields before starting your tractor and while mowing. We recommend a wide vision safety mask for over the spectacles or standard safety glasses.

UNPACKING INSTRUCTIONS

- Remove all parts and packing materials from carton.
- Fold flaps to inside of carton and turn carton upsidedown on floor of work area. To protect grass catcher cover during assembly place cover upsidedown on overturned carton.
- Check carton contents against list. Be sure all parts are there.







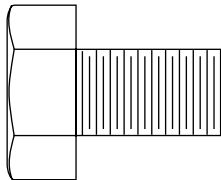
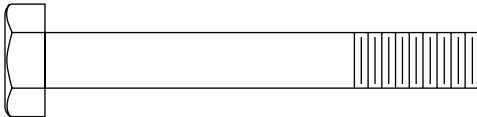
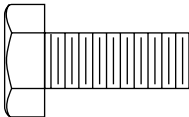
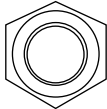

CARTON CONTENTS:

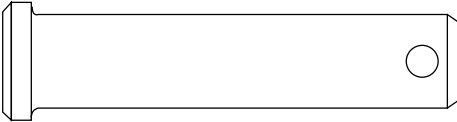
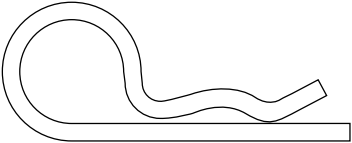
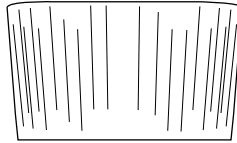
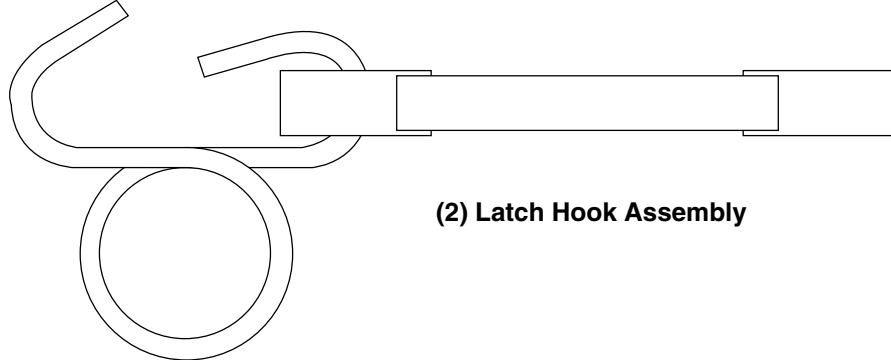
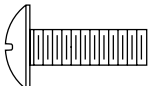
- | | |
|-----------------------|----------------------------|
| (3) Container Tops | (1) Mounting Support Plate |
| (3) Container Bottoms | (1) Cover Assembly |
| (1) Upper Chute | (1) Cover Seal |
| (1) Lower Chute | (1) Bag of Parts |
| (1) Support Post | (1) Owner's Manual |
| (1) Mounting Bracket | |

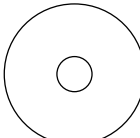
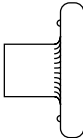
NOTE: For ease of assembly, aside of your work area, lay out all hardware in the following groups. Each step of the assembly instructions will identify the group needed for that step.

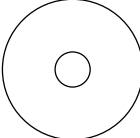
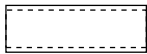
BAG OF PARTS CONTENTS	
ASSEMBLY LOCATION	HARDWARE SHOWN ACTUAL SIZE
REAR MOUNTING BRACKET AND SUPPORT PLATE TO DRAW BAR	GROUP "A"  (6) Bolt 7/16 - 14 x 3/4 Self Tapping
SUPPORT POSTS TO COVER ASSEMBLY	GROUP "B"  (2) Bolt 5/16 - 18 x 2-1/4  (2) Bolt 5/16 - 18 x 3/4  (4) Locknut 5/16-18

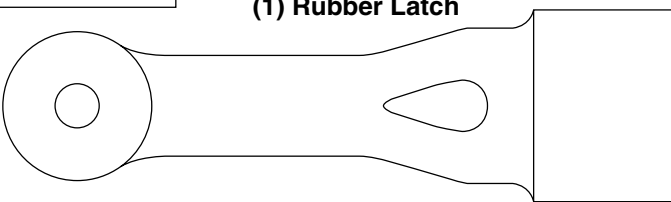
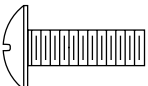
BAG OF PARTS CONTENTS (continued)

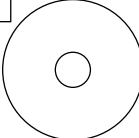
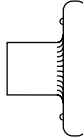
SUPPORT POSTS TO MOUNTING BRACKET	GROUP "C"	 (2) Support Clevis Pin	 (2) Retainer Spring	 (4) Tubing End Caps		
LOWER CHUTE ASSEMBLY TO MOWER DECK	GROUP "D"	 (2) Latch Hook Assembly	 (2) Screw #10 x 5/8	 (2) Washer, Lock #10	 (2) Washer 3/16 x 3/4 x 16 Ga.	 (2) Nut, Weld #10
CHUTE LATCH ASSEMBLY to UPPER CHUTE	GROUP "E"	 (1) Screw #10 x 1-1/8	 (2) Washer 3/16 x 3/4 x 16 Ga.	 (1) Spacer, Split #10	 (1) Nut, Acorn #10	
CHUTE LATCH ASSEMBLY to LOWER CHUTE	GROUP "F "	 (1) Rubber Latch	 (1) Screw #10 x 5/8	 (1) Washer, Lock #10	 (1) Washer 3/16 x 3/4 x 16 Ga.	 (1) Nut, Weld #10

ASSEMBLY

PARTS IDENTIFICATION

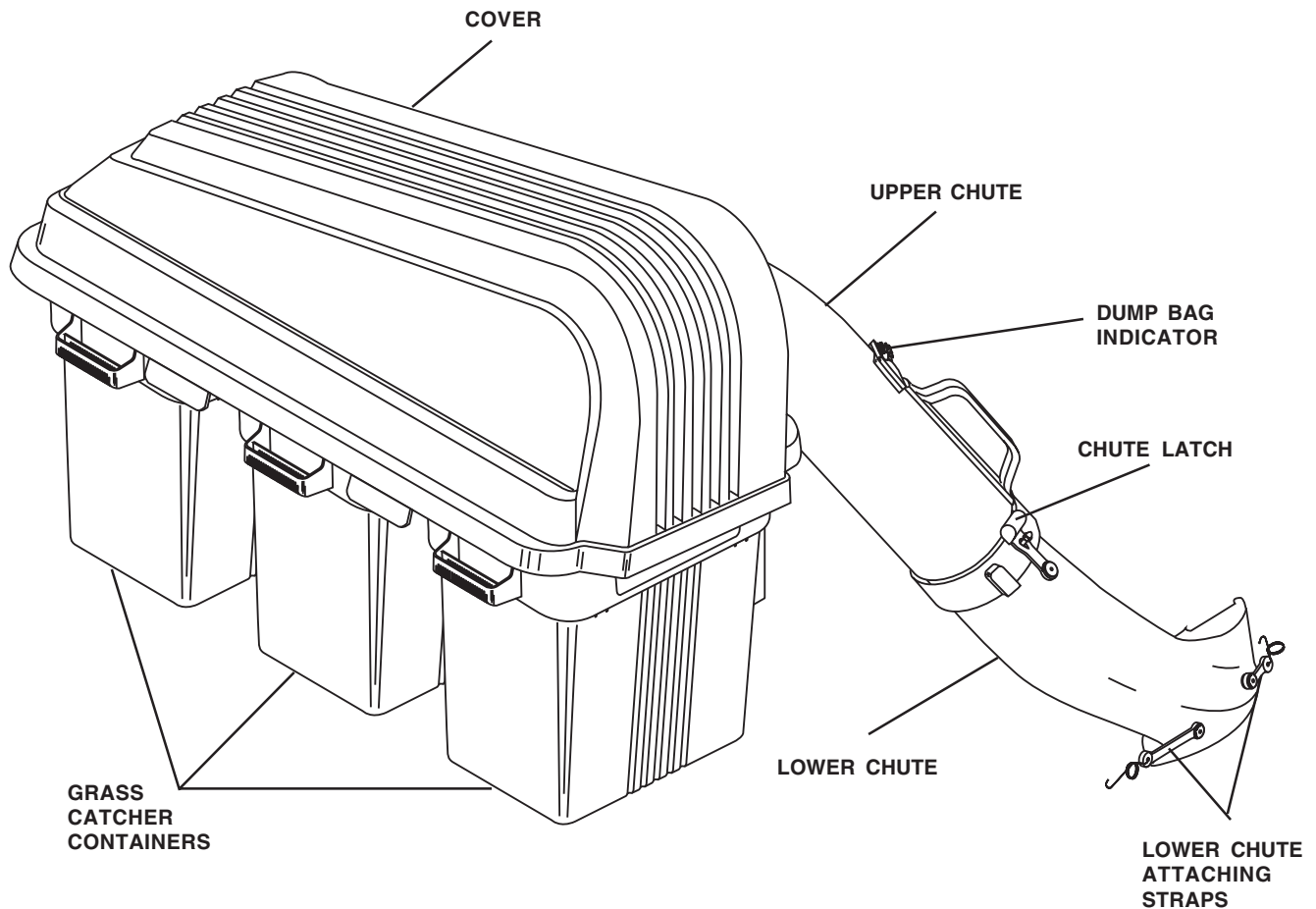

NOTE: When right hand (R.H.) and left hand (L.H.) are mentioned in this manual, it means when you are seated on the tractor, in the operator's position.

THESE ARE THE TOOLS YOU WILL NEED TO ASSEMBLE YOUR GRASS CATCHER:

(1) 1/2" Wrench
(1) 1/2" Socket
(1) 5/8" Socket
(1) Drive Ratchet

(1) 3" or longer Extension
(1) Short Handle
Phillips Screwdriver

CAUTION: BEFORE ASSEMBLING GRASS CATCHER TO TRACTOR:



- Depress clutch/brake pedal fully and set parking brake.
- Place gearshift/motion control lever in "NEUTRAL" position.
- Place attachment clutch in "DISENGAGED" position.
- Turn ignition key "OFF" and remove key.
- Make sure the blade and all moving parts have completely stopped.
- Disconnect spark plug wire from spark plug and place wire where it cannot come in contact with plug.

ASSEMBLY

1 REAR MOUNTING BRACKET and SUPPORT PLATE (See Figs. 1 & 2) Use Hardware - - GROUP "A"

- Install support plate to inside of drawbar as shown, using two (2) 7/16-14 x 3/4 hex bolts and the two threaded upper holes in the plate. Do not tighten at this time.

NOTE: Be sure to align the four (4) lower threaded holes of the support plate with the holes in the drawbar.

- Assemble the mounting bracket as shown to the outside of the drawbar using four (4) 7/16-14 x 3/4 hex bolts and the four (4) lower threaded holes of the support plate. Tighten all hardware securely.

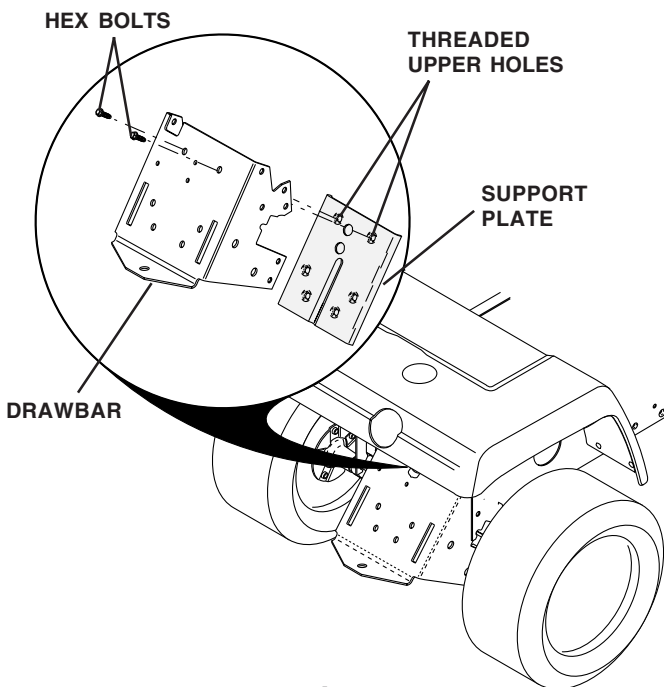

Fig. 1

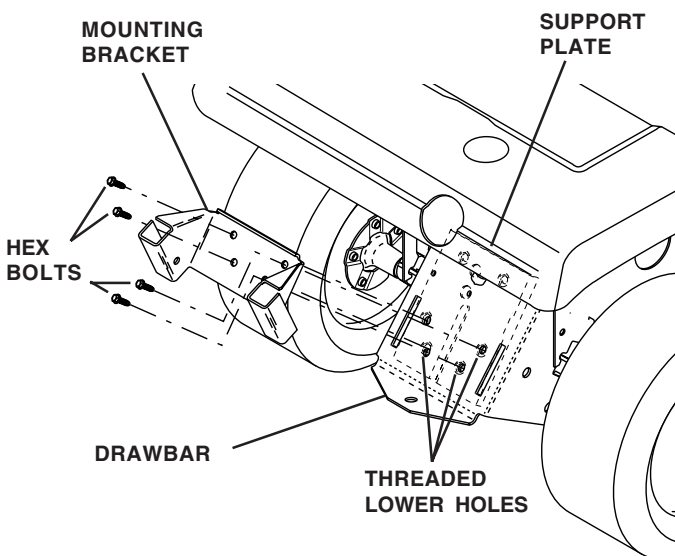

Fig. 2

2 COVER SEAL (See Fig. 3) No hardware required

- Align mark on seal with mark at cover opening.
- Work seal into opening so cover sits between flanges of seal.

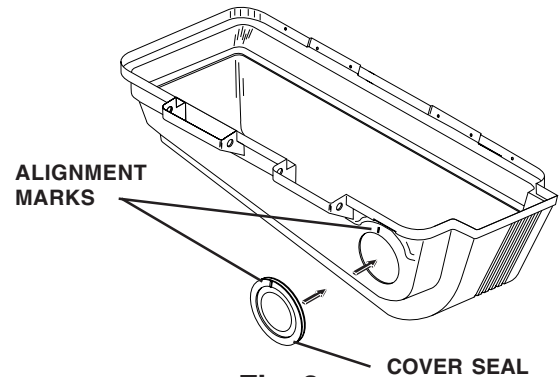

Fig. 3

3 SUPPORT POST (See Fig. 4) Use Hardware - - GROUP "B"



CAUTION: Container support is spring loaded and locked to the cover. Handle cover assembly carefully so as not to unlatch the cover from the container support.

- Rotate cover assembly onto its side as shown.
- Secure support tubes to cover assembly using short hex bolts, long hex bolts, and locknuts as shown. Tighten all hardware securely.

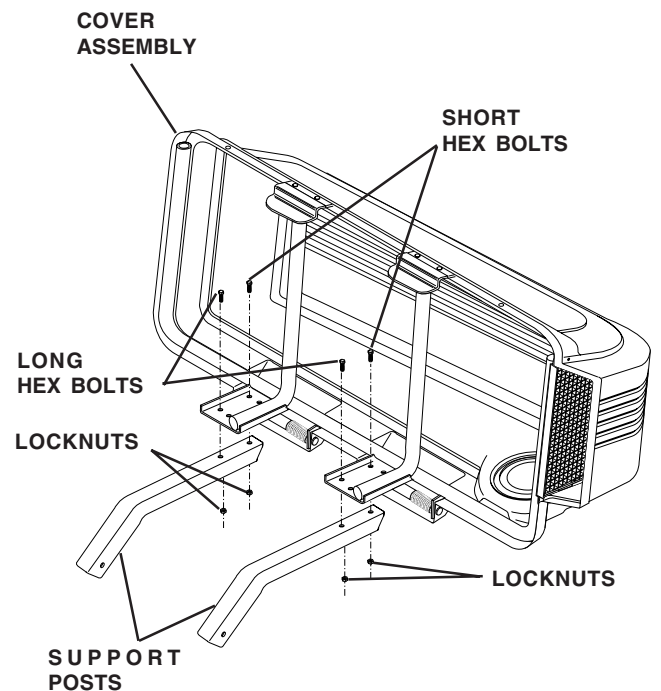

Fig. 4

ASSEMBLY

4 MOUNTING TO TRACTOR (See Fig. 5) Use Hardware - - GROUP "C"

NOTE: For ease of assembly, you may wish to obtain the assistance of another person for mounting assembly to tractor.

- Raise seat on tractor to allow assembly to be mounted.
- With cover closed, lift assembly and place support posts into mounting bracket. Allow assembly to rest on bottom of mounting bracket.
- Line up holes in mounting bracket with holes in support posts and insert support post clevis pins. Secure with retainer springs.
- Install the four (4) tubing end caps onto container support. Tap each end cap onto container support tubes to seat securely.

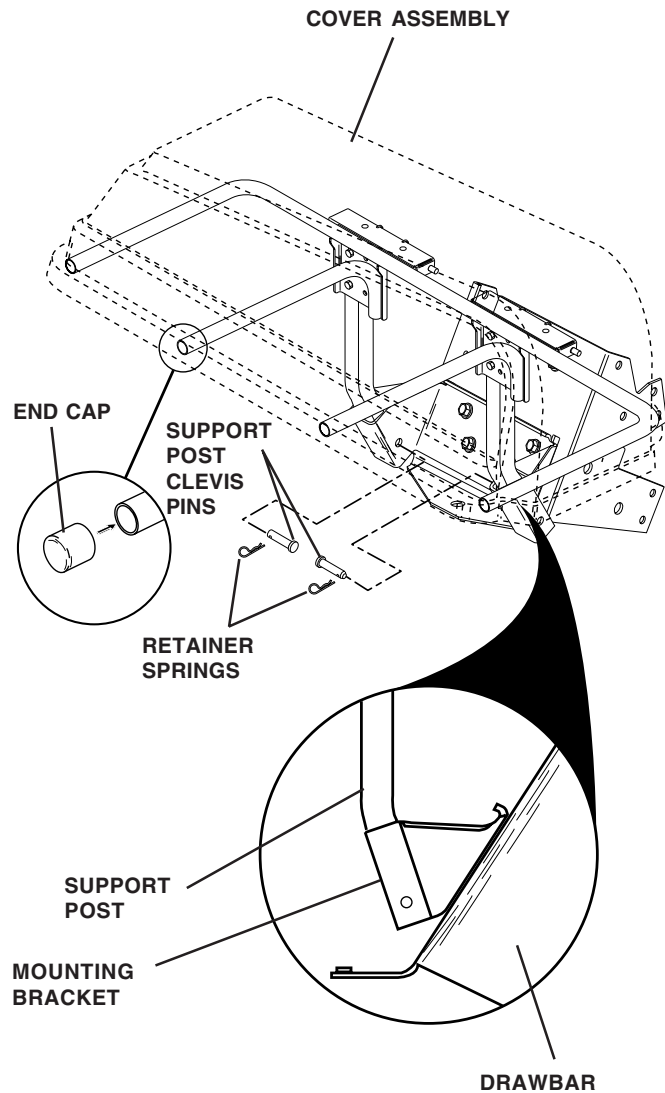

Fig. 5

5 CONTAINER ASSEMBLY (See Fig. 6) No hardware required

- Place bottom half inside of top half, as shown.
- Place one foot inside bottom half and lift top half to meet bottom half.
- Press halves tightly together while lifting top to lock into place as shown.

IMPORTANT: BEFORE LOCKING THE TABS, HOOKED EDGES ON BOTH HALVES MUST OVERLAP TO FORM SEAL AS SHOWN IN INSET.

- Repeat for second container.

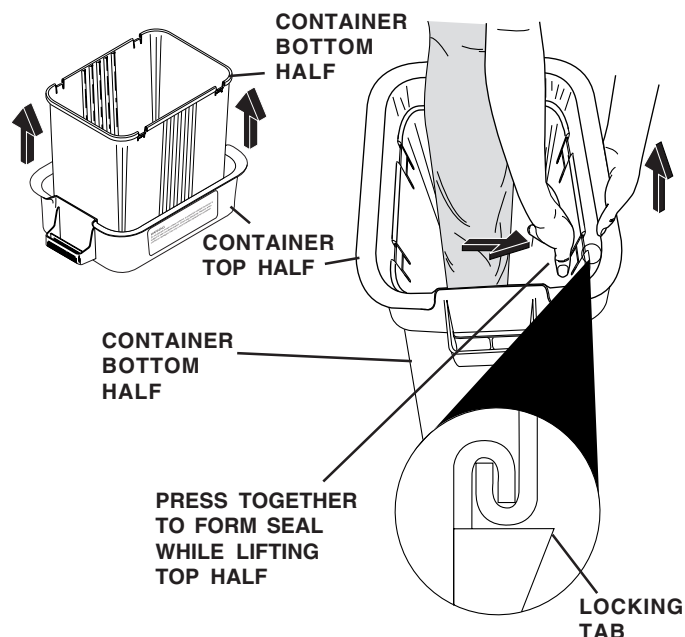

ASSEMBLY CHECK: Squeeze sides of lower half of container and check that there is no gap between upper and lower halves. If a gap appears, unlock tabs to separate container halves and repeat instructions above.

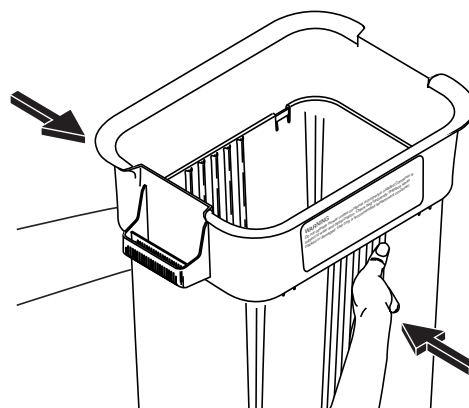

Fig. 6

ASSEMBLY

6 CONTAINER MOUNTING (See Fig. 7) No hardware required

- Install one container to left side first with warning to outside of unit. Install another container to center position and one in right position.

NOTE: Right container should always overlap left container at center supports.

- Close cover and lock latch handles over center support tubes.

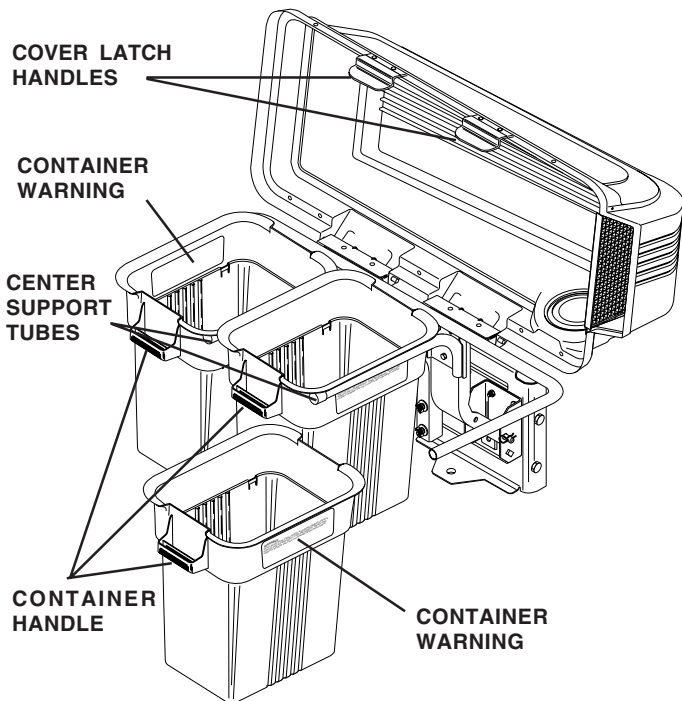

Fig. 7

7 LOWER CHUTE (See Fig. 8 & 9) Use Hardware - - GROUP "D"

- Press weld nut into rubber latch and install two latch hook assemblies to lower chute using screw, washer, and lock washer as shown.
- Tighten hardware securely.
- Raise and hold deflector shield in upright position.
- Place rear of chute over rear of mower deck opening. Push chute down and forward to guide extended edge of chute between discharge guard and mower deck.
- Hook front latch into tab hole on front of mower deck.
- Hook rear latch into flange hole on back of mower deck.



CAUTION: Do not remove discharge guard from mower. Raise and hold guard when attaching lower chute and allow it to rest on chute while in operation.

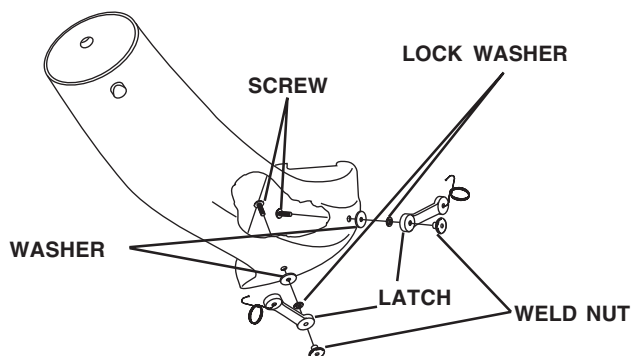

Fig. 8

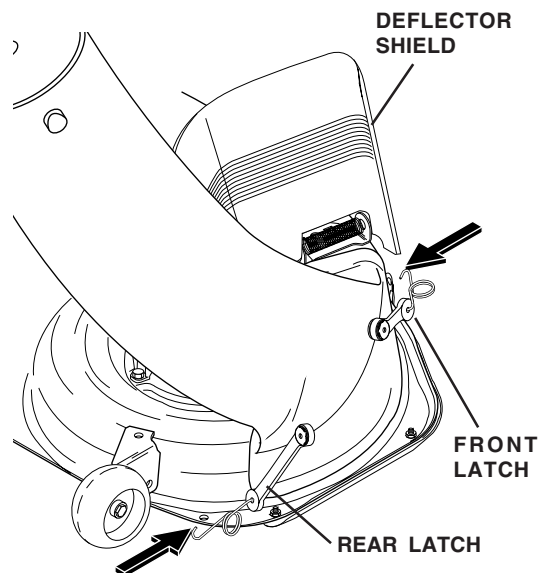

Fig. 9

ASSEMBLY

8 CHUTE LATCH ASSEMBLY (See Fig. 10)

Use Hardware - - GROUP "E & F"

- Assemble hardware shown (latch pin) to upper chute.
- Press weld nut into rubber latch and assemble rubber latch to lower chute, as shown.
- Tighten all hardware securely.

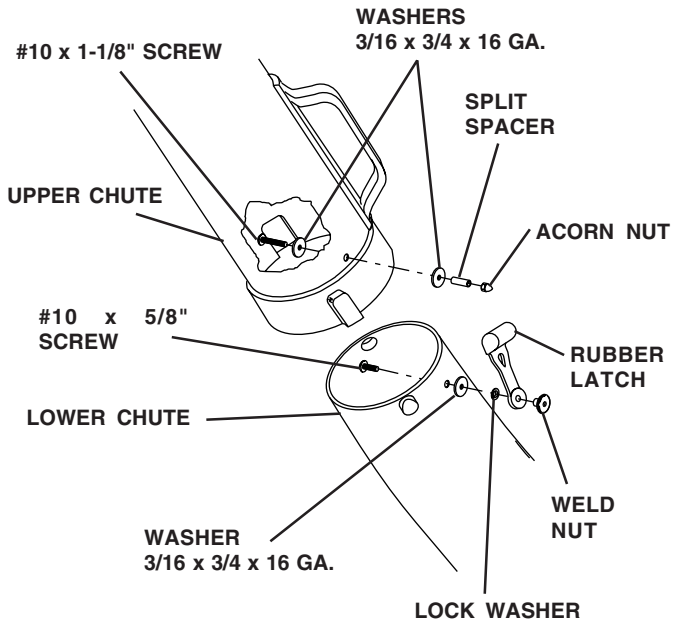

Fig. 10

9 UPPER CHUTE (See Fig. 11 & 12) No hardware required

- Lower mower deck to its lowest cutting position.
- Assemble upper chute by inserting curved end into hole in back of cover.

NOTE: Handle carefully so as not to damage full bagger indicator.

- Push in and turn upper chute until it is in line with lower chute.
- Align the bosses on lower chute with alignment slots on upper chute and slide together.
- Secure with rubber latch by hooking hole in latch over latch pin.

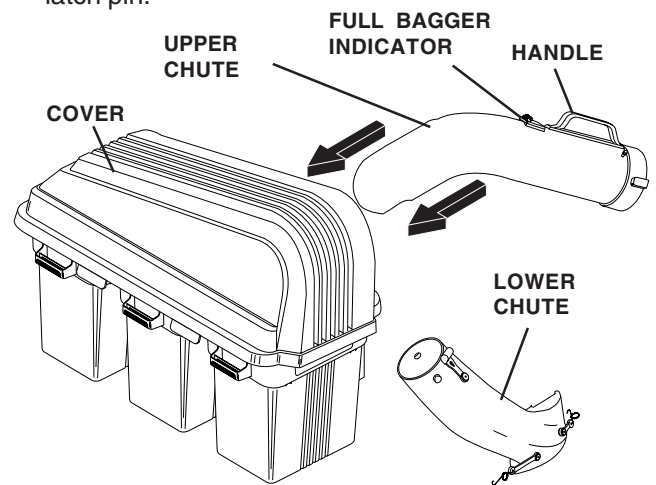

Fig. 11

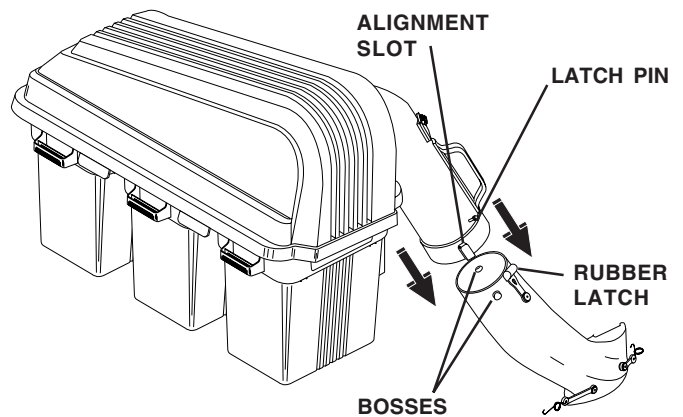

Fig. 12

10 LEVEL MOWER DECK No hardware required

- Be sure deck is properly leveled for best mower performance. See your tractor's owner's manual for instructions.

OPERATION

TIPS FOR IMPROVED BAGGING OPERATION:

Follow the mower operation instructions in your tractor owner's manual.

When operating your grass catcher on a lawn where grass and leaf bagging equipment has not been used, you are picking up thatch and debris that has accumulated for long periods of time. The amount collected and the total time of operation may be greater than you will experience with regular use of your grass catcher.

- Always run throttle at full speed when bagging.
- Select a gear low enough to give good mower cutting performance, good quality cut and good bagging performance.

NOTE: It may be necessary to overlap width of cut to suit your conditions.

- If grass is extremely tall, it should be mowed twice. The first time relatively high, the second time to desired height.
- Use left hand side of mower for trimming.
- Plastic trash bags can be inserted inside grass catcher containers for ease of debris disposal. To remove the plastic trash bags when full:
 - a. Raise seat. Unlatch and raise cover.
 - b. Remove one container at a time by grasping container handles and pulling toward the rear, off of the tube rails.
 - c. With the container resting on the ground, close and secure the top of the plastic lawn bag.
 - d. Tip the container on its side and slide the filled bag from the container.
 - e. Install a new plastic lawn bag with the edges of the bag draped over upper lip of the Container (for replacement bags refer to REPLACEMENT PARTS).
 - f. Repeat for other containers.
 - g. Reinstall containers making sure right container overlaps left container at center supports.
 - h. Close cover and secure latches over center support tubes.

- Avoid cutting wet grass or in the morning while the dew is still heavy. Grass clippings collected under these conditions tend to be sticky and adhere to the walls of the flow path causing clogging.
- Your bagger is equipped with a dump bag indicator. As the bags become full, movement of the wheel will slow down and/or stop, indicating that the bags are full or the chutes have become clogged. Care should be taken not to damage the parts and that the wheel spins freely at the beginning of each use.
- If the grass catcher fails to pick up cut grass or leaves, it is an indication that clogging has occurred in the system or that the grass catcher containers are full. Usually this is indicated by the stopped movement of the dump bag indicator.
 - a. Disengage blades, shift into neutral, engage the parking brake and stop the engine.
 - Raise seat. Unlatch and raise cover.
 - Slide out containers and dispose of clippings .
 - Replace containers, close cover, and latch.
 - b. Unlatch chutes and check for clogging
 - Remove all debris in chutes.
 - Reassemble and latch chutes
 - c. Check to insure dump bag indicator has not become clogged.
 - The air passage hole must be clear of debris. Gently insert a small twig or wire into passage-way to clear.



CAUTION

- **Do not operate mower with grass catcher partially installed.**
- **Disengage blades and stop engine before leaving tractor seat to empty containers, unclogging chutes, etc.**
- **Close cover before starting.**
- **Disengage mower when crossing driveways or gravel surfaces and other areas where thrown objects could be a hazard.**
- **Do not attempt to vacuum up cans or other potentially hazardous projectiles.**

CUSTOMER RESPONSIBILITIES

GENERAL RECOMMENDATIONS

Always observe safety rules when performing any maintenance.

- Before each use check for loose fasteners.
- Clean unit thoroughly after each use.

BLADE CARE

For best results mower blades must be kept sharp. Replace bent or damaged blades.

- See BLADE CARE instructions in your tractor owner's manual.



CAUTION: BEFORE PERFORMING ANY MAINTENANCE, SERVICE OR ADJUSTMENTS:

- Depress clutch brake pedal fully and set parking brake.
- Place gearshift/motion control lever in "NEUTRAL" position.
- Place clutch control in "DISENGAGED" position.
- Turn ignition key to "OFF" position.
- Make sure blades and all moving parts have completely stopped.
- Disconnect spark plug wire(s) from spark plug(s) and place wire where it cannot come in contact with plug.



CAUTION: Grass catcher components are subject to wear, damage and deterioration, which could expose moving parts or allow objects to be thrown. Frequently check components and replace with manufacturer's recommended parts, when necessary.

STORAGE

When grass catcher is to be stored for a period of time, clean it thoroughly, remove all dirt, grass, leaves, etc. Store in a clean, dry place.



CAUTION: Do not leave grass in bagger containers. Empty containers after each use and before storing. Failure to do so may result in spontaneous combustion which could develop into a fire.

TO REMOVE GRASS CATCHER

Reverse appropriate steps in **ASSEMBLY** section of this manual.

SERVICE NOTES

REPAIR PARTS/PIÈCES DE RECHANGE

GRASS CATCHER - MODEL NUMBER CG46A / RAMASSE-HERBE - NUMÉRO DE MODÈLE CG46A
PRODUCT NUMBER 954 04 00 06-07 / NUMÉRO DE PRODUIT 954 04 06-07

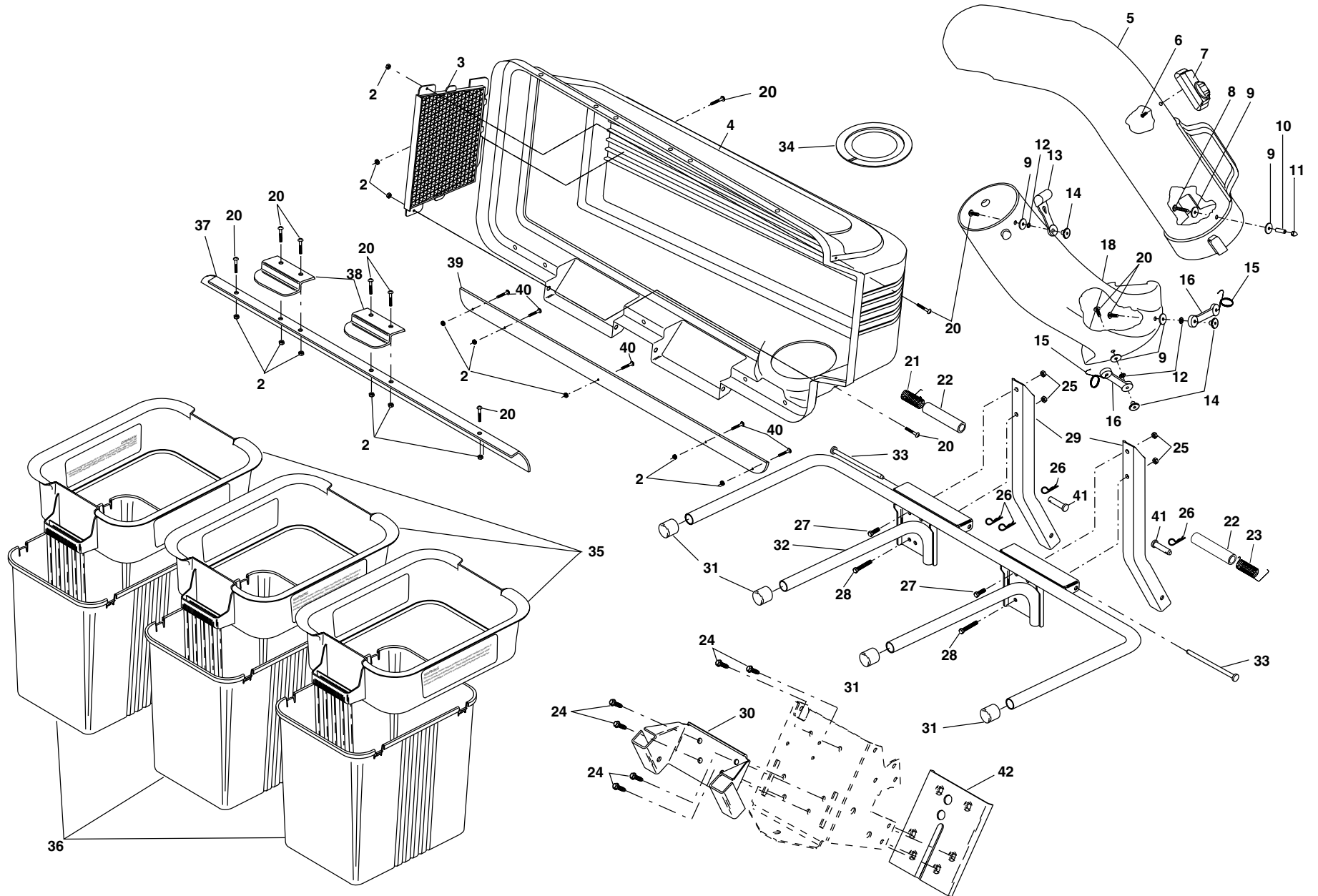

REPAIR PARTS/PIÈCES DE RECHANGE

GRASS CATCHER - MODEL NUMBER CG46A / RAMASSE-HERBE - NUMÉRO DE MODÈLE CG46A
 PRODUCT NUMBER 954 04 00 06-07 / NUMÉRO DE PRODUIT 954 04 06-07

KEY NO.	PART NO.	DESCRIPTION	KEY NO.	PART NO.	DESCRIPTION
2	532069180	Nut, Crownlock #10-24	25	532063124	Locknut 5/16 x 18
3	532127533	Screen, Cover	26	532124670	Spring, Retainer
4	532134678	Cover	27	874760512	Bolt, Hex 5/16-18 x 3/4
5	532126840	Chute, Upper	28	874760536	Bolt, Hex 5/16-18 x 2-1/4
6	818021008	Screw, Special #10-14x1/2	29	532144840	Bagger, Support Post
7	532140572	Dump Bagger Indicator	30	532144839	Bracket, Mounting
8	532087175	Screw, #10-24 x 1-1/8	31	532134496	Plug, Tubing End
9	819061216	Washer 3/16x3/4x16 Ga.	32	532134639	Bagger, Frame
10	532007206	Spacer, Split	33	532128600	Pin, Hinge
11	532060867	Nut, Acorn #10-24	34	532127534	Gasket, Cover
12	810071000	Washer, Lock	35	532129585	Container, Top
13	532109808	Latch, Chute	36	532129586	Container, Bottom
14	532125004	Nut, Weld	37	532134637	Seal, Cover
15	532130760	Latch, Hook	38	532130895	Latch Handle, Cover
16	532130759	Rubber, Latch	39	532155857	Strip, Reinforcement
18	532145578	Chute, Lower	40	871141008	Screw #10-24 x 1/2
20	871161010	Screw #10-24 x 5/8	41	532145326	Pin, Clevis
21	532132796	Spring, Cover L.H. (black)	42	532145892	Plate, Reinforcement
22	532140809	Spacer, Cover	—	532104419	Bag, 3.0 mil. 30 Gallon
23	532132983	Spring, Cover R.H. (gray)			Trash (not included with bagger)
24	874780712	Bolt, 7/16-14 x 3/4	—	532151673	Owner's Manual
					Écrou frein 5/16 x 18
					Ressort de retenue
					Boulon H 5/16-18 x 3/4
					Boulon H 5/16-18 x 2-1/4
					Support du ramasse-herbe
					Support de montage
					Capuchon d'extrémité de tuyau
					Cadre de ramasse-herbe
					Goupille de charnière
					Garniture de couvercle
					Bac à gazon supérieur
					Bac à gazon inférieur
					Sceau de couvercle
					Poignée de loquet de couve
					Bande
					Vis #10-24 x 1/2
					Axe de chape
					Plaque de renforcement
					Sac-poubelle; 3,0 mil. 30 gallon (N'y pas compris avec le ramasse-herbe)
					Manuel de propriétaire