

# **Operator's manual Rider ProFlex 21 II**



Please read these instructions carefully and make sure you understand them before using the machine.

**English**



# Operator's Manual for Rider ProFlex 21 II

## Contents

<b>Contents</b> .....	1	Adjusting of the Hydrostatic Transmission Cable....	31
For Your Own Safety .....	2	Cable Seat .....	31
<b>Introduction</b> .....	3	Adjusting the Brake .....	32
Driving and Transport on Public Roads .....	3	Checking the Tyre Pressures.....	32
Towing .....	3	Replacing the Air Filter .....	33
Use.....	3	Replacing the Fuel Filter .....	34
Proper Service .....	4	Cleaning the Pulse Air Filter.....	34
Serial Number .....	4	Checking the Fuel Pump's Air Filter.....	34
<b>Symbols and Decals</b> .....	5	Checking the Battery Acid Level .....	35
<b>Safety Instructions</b> .....	7	Ignition System.....	35
General Use.....	7	Main Fuse .....	36
Driving on Slopes .....	9	Checking the Safety System .....	36
Children.....	10	The Cutting Unit Components.....	37
Maintenance .....	10	Attaching the Cutting Unit .....	37
Transport.....	12	Adjusting the Unit's Parallelism and Cutting Height .....	39
<b>Presentation</b> .....	13	Parallelism.....	39
Placement of Controls.....	13	Cutting Height .....	39
Throttle Control .....	14	Checking and Adjusting the Ground Pressure .....	40
Choke Lever.....	14	The Cutting Unit's Service Position.....	40
Accelerator.....	14	Checking the Blades .....	41
Cutting Unit .....	15	Cutting Unit Model.....	41
Accessories.....	15	Removing the Cutting Unit .....	42
Hydraulic Lifting Lever for the Cutting Unit .....	15	Removing the Cutting Unit Frame.....	44
Mechanical Lifting Lever for the Cutting Unit .....	16	Removing the Belt.....	44
Cutting Height Adjustment Lever .....	17	Attaching the Belt.....	45
Parking Brake .....	17	Changing the Cutting Unit's Belt .....	46
Seat.....	17	Removing the BioClip Plug (Combi).....	46
Fuelling .....	17	<b>Lubrication</b> .....	47
Differential Lock .....	18	Lubrication Schedule.....	47
Clutch Control .....	18	General .....	48
Chronometer .....	18	Lubricating the Cables .....	48
<b>Driving</b> .....	19	Lubricating in Accordance with the Lubrication Schedule.....	48
Before Starting .....	19	<b>Trouble Shooting Guide</b> .....	55
Starting the Engine .....	19	Problem.....	55
Driving the Rider .....	20	<b>Storage</b> .....	57
Differential Lock .....	21	Winter Storage .....	57
Mowing Tips.....	22	Service .....	58
Stopping the Engine.....	23	<b>Electrical and Hydraulic Systems</b> .....	59
Clutch Control .....	24	<b>Technical Data</b> .....	61
<b>Maintenance</b> .....	25	Rider ProFlex 21 II .....	61
Maintenance Schedule .....	25	Cutting Unit .....	62
Removing the Rider's Covers .....	27	<b>EU Declaration of Conformity</b> .....	63
Checking the Engine's Cooling Air Intake .....	28	<b>Service journal</b> .....	65
Checking the Transmission Air Intake .....	28	Delivery Service .....	65
Checking and Adjusting the Steering Cables.....	29	After the first 8 hours.....	65
Checking and Adjusting the Throttle Cable.....	30	25-Hour Service .....	66
Checking and Adjusting the Choke Cable .....	30	50-Hour Service .....	67
Adjusting of the Differential Lock .....	30	100/200-Hour Service .....	68
		300-Hour Service .....	69
		At Least Once Each Season.....	70

### **IMPORTANT INFORMATION**

**Read carefully through the Operator's manual so that you know how to use and maintain the Rider before you use it.**

**For service measures other than those described in this manual, please contact an authorised dealer that provides parts and service.**

## **For Your Own Safety**

### **Insure your Rider**

- Check the insurance
- Contact your insurance company
- You should have fully comprehensive insurance for: Traffic-Fire-Damage-Theft.

---

# INTRODUCTION

---

## Introduction

### Congratulations

Thank you for purchasing a Husqvarna Rider. Husqvarna Riders have been designed according to a unique concept with a front mounted cutting unit and patented rear wheel steering. The Rider is built to give maximum efficiency even in small and confined areas. All controls in one place and a hydrostatic transmission regulated by foot pedals also contribute to the machine's performance.

This operator's manual is a valuable document. Following the instructions (use, service, maintenance, etc.) can considerably increase the life span of your machine and even increase its resale value.

When you sell your Rider, make sure to give the operator's manual to the new owner.

The final chapter of this operator's manual comprises a Service Journal. Ensure that service and repair work is documented. A well-kept service journal reduces service costs for the season-based maintenance and affects the machine's resale value. Take the operator's manual along when the Rider is left to the workshop for service.

### Driving and Transport on Public Roads

Check applicable road traffic regulations before driving and transport on public roads. You should always use approved fasteners during transport and ensure that the machine is well secured.

### Towing

Your machine is equipped with a hydrostatic transmission and, if necessary, you ought only tow the machine over short distances and at a low speed, otherwise there is a risk of damaging the transmission.

The power transmission must be disengaged when towing, see Clutch Control on page 18.

### Use

This machine is constructed only for cutting grass on normal lawns and other free and even ground without obstacles such as stones, tree stumps, etc., even when the machine is equipped with special accessories provided by the manufacturer, for which the operating instructions are provided in conjunction with delivery. All other types of use are incorrect. The manufacturer's instructions with regard to driving, maintenance, and repair must be followed precisely.

The machine may only be operated, maintained, and repaired by persons that are fully conversant with the machine's special characteristics and safety regulations.

Accident prevention regulations, other general safety regulations, occupational safety rules, and traffic regulations must be observed.

Unauthorised modifications to the design of the machine may absolve the manufacturer from liability for any resulting personal injury or property damage.

---

# INTRODUCTION

---

## Proper Service

Husqvarna's products are sold all over the world and only by specialised retail traders offering complete service. This ensures that you as a customer receive only the best support and service. Before the product is delivered, the machine has, for example, been inspected and adjusted by your retailer, see the certificate in the Service Journal in this operator's manual.

When you need spare parts or support concerning service, warranty issues, etc., please consult the following professional:

This operator's manual belongs to the machine bearing serial number:	Engine	Transmission

## Serial Number

The serial number can be found on the printed plate attached to the front, left-hand side under the seat. Stated on the plate, from the top, are:

- The machine's type designation.
- The manufacturer's type number.
- The machine's serial number.

Please state the type designation and serial number when ordering spare parts.

The engine's serial number is stated on a barcode decal. This is placed on the left side of the crankcase, in front of the starter. The plate states:

- The engine's serial number (E/NO).
- Code.

Please state these when ordering spare parts.

The transmission's serial number is stated on the barcode decal located on the front of the housing on the left-hand drive axle:

- The type designation is stated above the barcode and starts with the letter K.
- The serial number is stated above the barcode and has the prefix s/n.
- The manufacturer's type number is stated under the barcode and has the prefix p/n.

Please state the type designation and serial number when ordering spare parts.

# EXPLANATION OF SYMBOLS

## Symbols and Decals

These symbols can be found on the rider and in the operator's manual. Study them carefully so that you know what they mean.



Read the operator's manual.

**R**

Reverse

**N**

Neutral



Fast



Slow



Engine off



Battery



Choke



Fuel



Oil level



Cutting height



Reversing



Forward



START

Ignition



Use hearing protection

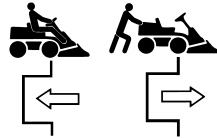

Hydrostatic free wheeling



Parking brake



Brake



Warning



Noise emission to surroundings in accordance with the directive of the European Community. The machine's emission is indicated in the TECHNICAL DATA chapter and on the decal.



Warning! Rotating blades



Warning! Risk of the Rider overturning



Never drive directly across a slope



CE conformity marking



Never use the Rider if persons, especially children or pets, are in the immediate vicinity.



Never carry passengers on the Rider or on its tools

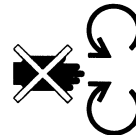

Do not insert your hands or feet under the cover when the engine is running



Drive very slowly without the cutting unit

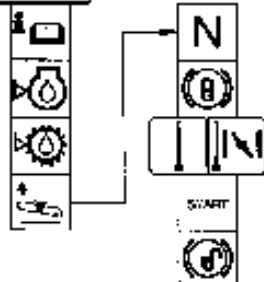
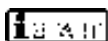

Starting instructions  
 Read the operator's manual  
 Check the engine oil level  
 Check the oil level in the hydrostat  
 Lift up the cutting unit  
 Put the hydrostat pedals in the neutral position  
 Brake  
 Use the choke if the engine is cold  
 Start the engine  
 Disengage the parking brake before driving



Accelerator pedal forward  
 Neutral position  
 Accelerator pedal reversing



Switch off the engine and remove the ignition cable before carrying out repairs or maintenance

---

# EXPLANATION OF SYMBOLS

---



**WARNING!**

Xxxxxxx xxxx xxxxxxxx xxx x

Xxxxx xxxxxx xx.

xx xxxxxxxx xxxxx xxx xx.

Used in this publication to notify the reader of a risk of **personal injury**, particularly if the reader should neglect to follow instructions given in the manual.

**IMPORTANT INFORMATION**

Xxxxxxx xxxx xxxxxxxx xxx xxx

xxxx xxxxxx xx.

Used in this publication to notify the reader of a risk of **material damage**, particularly if the reader should neglect to follow instructions given in the manual. Used also when there is a potential for misuse or misassembly.

Avoid hosing the decals with high pressure washers. Replace damaged decals before the machine is used.



# SAFETY INSTRUCTIONS

## Safety Instructions

These instructions are for your safety. Read them carefully.



### WARNING!

The inserted symbol means that important safety instructions needed to be observed. It applies to your safety.

### General Use

- Read all instructions in this operator's manual and on the machine before starting it. Ensure you understand them and then observe them.
- Learn how to use the machine and its controls safely and learn how to stop quickly. Also learn to recognise the safety decals.
- Only allow the machine to be used by adults who are familiar with its use.
- Make sure nobody else is in the vicinity of the machine when you start the engine, engage the drive, or run the machine.
- Make sure animals and people maintain a safe distance from the machine.
- Stop the machine if someone enters the work area.
- Clear the area of objects such as stones, toys, steel wire, etc. that may become caught in the blades and thrown out.
- Beware of the discharge deck and do not point it at any one.
- Stop the engine and prevent it from starting before you clean the discharge deck.
- Remember that the driver is responsible for dangers or accidents.
- Never take passengers. The machine is only intended to be used by one person.
- Always look down and behind before and during reversing manoeuvres. Keep watch for both large and small obstacles.
- Slow down before turning.
- Shut down the blades when not mowing.

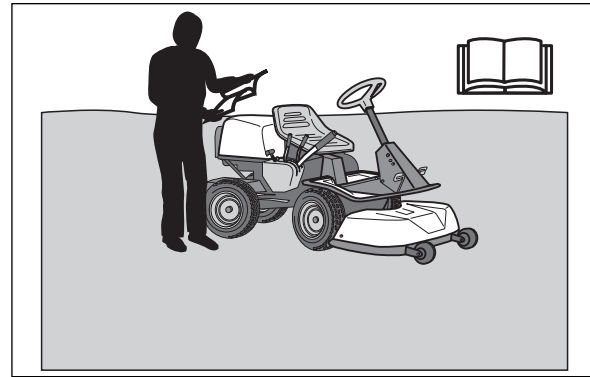

8010-047

*Read the operator's manual before starting the machine.*

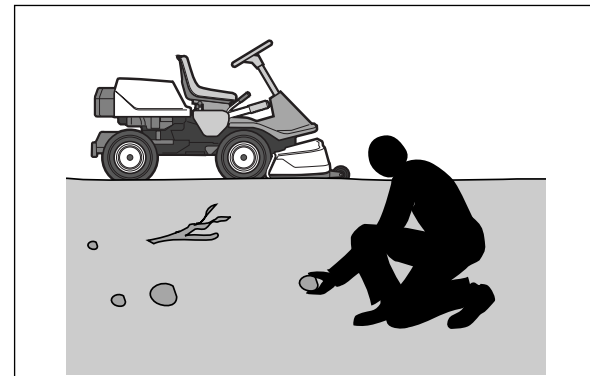

6003-002

*Clear the area of objects before mowing.*

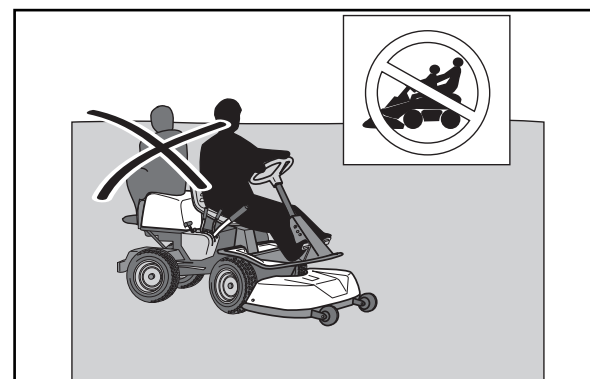

8010-052

*Never take passengers.*



### WARNING!

This machine can sever hands and feet as well as throw objects. Failure to observe the safety instructions can result in serious injuries.

# SAFETY INSTRUCTIONS

- Be careful when rounding fixed objects, so that the blades do not hit them. Never run the machine over foreign objects.
- Only use the machine in daylight or in other well-lit conditions. Keep the machine at a safe distance from holes or other irregularities in the ground. Pay attention to other possible risks.
- Never use the machine if you are tired, if you have consumed alcohol, or if you are taking other drugs or medication that can affect your vision, judgment, or coordination.
- Beware of traffic when working near or crossing a road.
- Never leave the machine unsupervised with the engine running. Always stop the blades, apply the parking brake, stop the engine and remove the keys before leaving the machine.
- Never allow children or other persons not trained in the use of the machine to use or service it. Local laws may regulate the age of the user.



## WARNING!

Engine exhaust, some of its constituents and certain vehicle components contain or emit chemicals considered to cause cancer, birth defects or other reproductive impairment. The engine emits carbon monoxide, which is a colourless, poisonous gas. Do not use the machine in enclosed spaces.

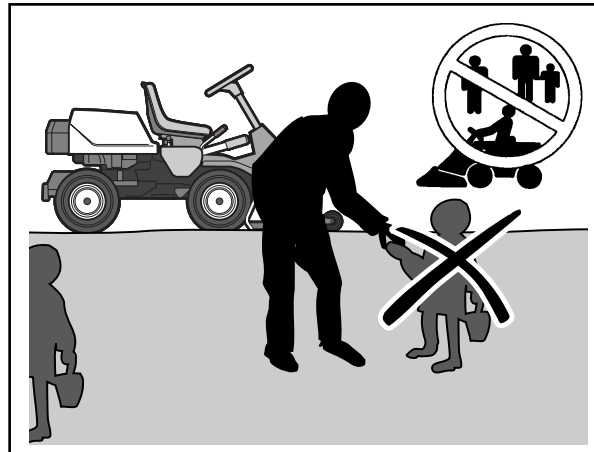

6003-006

*Keep children away from the area to be mowed.*



## WARNING!

You must use approved personal protective equipment whenever you use the machine. Personal protective equipment cannot eliminate the risk of injury but it will reduce the degree of injury if an accident does happen. Ask your dealer for help in choosing the right equipment.

- Make sure that you have first aid equipment close at hand when using the machine.
- Never use the machine when barefoot. Always wear protective shoes or protective boots, preferably with steel toes.
- Always wear approved protective glasses or a full visor when assembling or driving.
- Never wear loose clothing that can fasten in moving parts.
- Use hearing protection when driving the machine. Consult your dealer concerning the appropriate protection level.



8011-292

*Personal protective equipment.*

# SAFETY INSTRUCTIONS

## Driving on Slopes

Driving on slopes is one of the operations where the risk of the driver losing control of the machine or of it overturning is the greatest; this can result in serious injury or death. All slopes demand extra care. If you cannot reverse up a slope or if you feel unsure, do not mow it.

### Do as follows

- Remove obstacles such as stones, tree branches, etc.
- Mow up and down, not side-to-side.
- Never drive the machine on terrain that slopes more than 15°.
- Avoid starting or stopping on a slope. If the tyres start to slip, stop the blades and drive slowly down the slope.
- Always drive evenly and slowly on slopes.
- Make no sudden changes in speed or direction.
- Avoid unnecessary turns on slopes, and if it proves necessary, turn slowly and gradually downward, if possible.
- Watch out for and avoid driving over furrows, holes, and bumps. It is easier for the machine to overturn on uneven ground. Tall grass can hide obstacles.
- Drive slowly. Do not turn the wheel sharply.
- Be extra cautious with any additional equipment, which can alter the machine's stability.
- Do not mow near verges, ditches, or banks. The machine can suddenly overturn if one wheel comes over the edge of a steep slope or a ditch, or if an edge gives way.
- Do not mow wet grass. It is slippery, and tyres can lose their grip so that the machine skids.
- Try not to stabilise the machine by putting a foot on the ground.
- When cleaning the chassis, the machine may never be driven near verges or ditches.
- Follow the manufacturer's recommendations regarding wheel weights or counterbalance weights to increase machine stability.

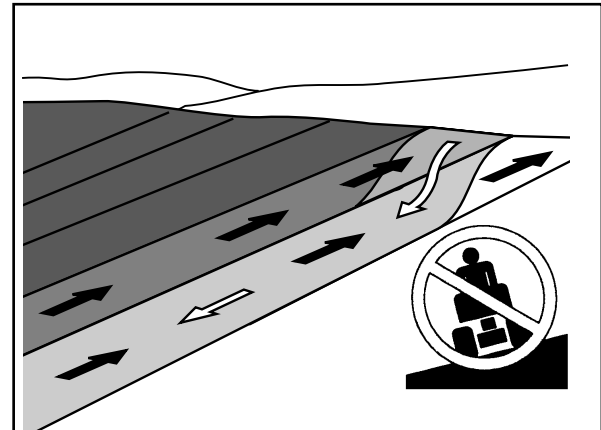

6003-004

*Mow upwards and downwards on slopes, not sideways.*

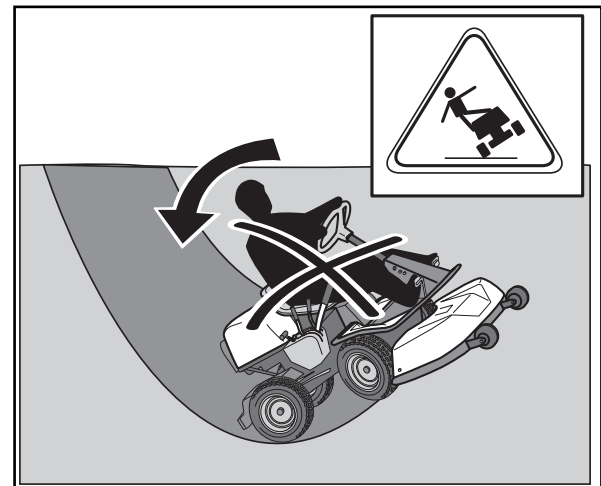

8010-054

*Be extra cautious when driving on slopes.*

### IMPORTANT INFORMATION

**Do not drive down slopes with the unit raised.**

### IMPORTANT INFORMATION

**Wheel weights fitted on the rear wheels are recommended when driving on slopes for safer steering and improved manoeuvrability. Consult your dealer concerning the use of wheel weights if you are unsure.**

# SAFETY INSTRUCTIONS

## Children

- Serious accidents may occur if you fail to be on guard for children in the vicinity of the machine. Children are often attracted to the machine and mowing. Never assume that children will stay put where you last saw them.
- Keep children away from the mowing area and under close supervision by another adult.
- Keep an eye out and shut off the machine if children enter the work area.
- Before and during a reversing manoeuvre, look backward and downward for small children.
- Never allow a child to ride with you. They can fall off and seriously injure themselves or be in the way for safe manoeuvring of the machine.
- Never allow children to operate the machine.
- Be particularly careful near corners, bushes, trees or other objects that block your view.

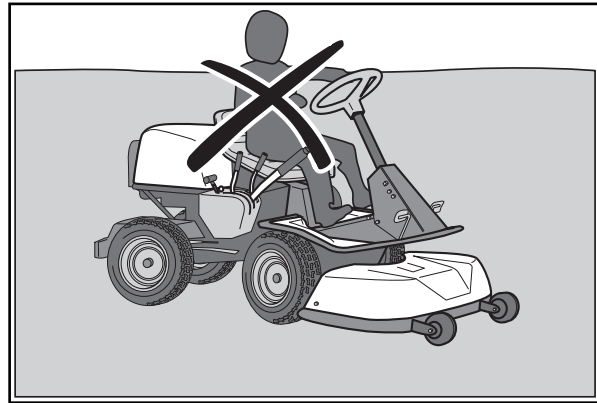

8010-057

*Never allow children to operate the machine.*

## Maintenance

- Stop the engine. Prevent the engine from starting by removing the spark plug cables from the spark plugs or by removing the ignition key before making any adjustments or performing maintenance.
- Never fill the fuel tank indoors.
- Petrol and petrol fumes are poisonous and extremely flammable. Be especially careful when handling petrol, as carelessness can result in personal injury or fire.
- Only store fuel in containers approved for the purpose.
- Never remove the fuel cap or fill the fuel tank while the engine is running.
- Allow the engine to cool before refuelling. Do not smoke. Do not fill petrol in the vicinity of sparks or naked flames.



8010-058

*Never fill the fuel tank indoors.*

# SAFETY INSTRUCTIONS

- If leaks arise in the fuel system, the engine must not be started until the problem has been resolved.
- Store the machine and fuel in such a way that there is no risk of leaking fuel or fuel vapour leading to damages.
- Check the fuel level before each use and leave space for the fuel to expand, because the heat from the engine and the sun may otherwise cause the fuel to expand and overflow.
- Avoid overfilling. If you spill petrol on the machine, wipe up the spill and wait until it has evaporated before starting the engine. If you spill petrol on your clothing, change your clothing.
- Allow the machine to cool before taking any actions in the engine room.
- Be especially careful when handling battery acid. Acid on the skin can cause serious corrosive injuries. In the event of spillage on the skin wash immediately with water.
- Acid in the eyes can cause blindness, contact a doctor immediately.
- Be careful when servicing the battery. Explosive gases form in the battery. Never perform maintenance on the battery while smoking or in the vicinity of open flames or sparks. This can cause the battery to explode and cause serious injuries.
- Make sure all nuts and bolts are tightened correctly and that the equipment is in good condition.
- Do not modify safety equipment. Check regularly to be sure it works properly. The machine must not be driven if protective plates, protective covers, safety switches or other protective devices are not fitted or are defective.
- Do not change the settings of governors and avoid running the engine with overly high engine speeds. If you run too fast, you risk damaging the machine components.



## WARNING!

The engine, and components of the exhaust and hydraulic systems become extremely hot during operation. Risk of burn injuries if touched.



## WARNING!

The battery contains lead and lead compounds, chemicals that are considered to cause cancer, birth defects, and other reproductive system damage. Wash your hands after touching the battery.

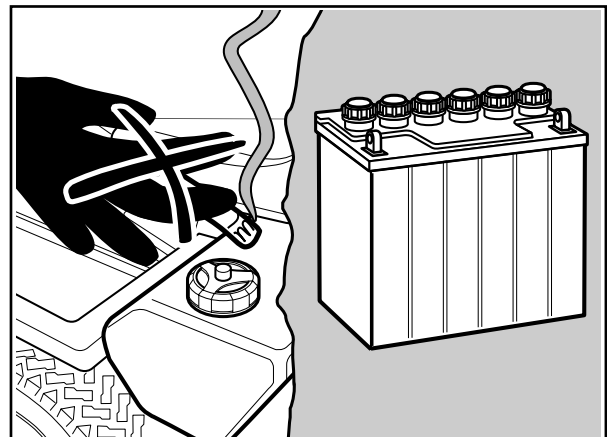

6003-009

*Do not smoke when carrying out maintenance.*

# SAFETY INSTRUCTIONS

- Never use the machine indoors or in spaces lacking proper ventilation. Exhaust fumes contain carbon monoxide, an odourless, poisonous and highly dangerous gas.
- Stop and inspect the equipment if you run over or into anything. If necessary, make repairs before starting.
- Never make adjustments with the engine running.
- The machine is tested and approved only with the equipment originally provided or recommended by the manufacturer.
- The blades are sharp and can cause cuts and gashes. Wrap the blades or wear protective gloves when handling them.
- Check the parking brake's functionality regularly. Adjust and maintain as required.
- The mulching unit should only be used where better quality mowing is required and in known areas.
- Reduce the risk of fire by removing grass, leaves and other debris that may have fastened in the machine. Allow the machine to cool before putting it in storage.

## Transport

- The machine is heavy and can cause serious crush injuries. Be especially careful when it is loaded in or out of a car or on and off of a trailer.
- Use an approved trailer to transport the machine. Activate the parking brake, shutoff the fuel supply and secure the machine using approved fasteners, such as tension belts, chains or ropes when transporting.
- Check and abide by local traffic regulations before transporting or driving the machine on any road.

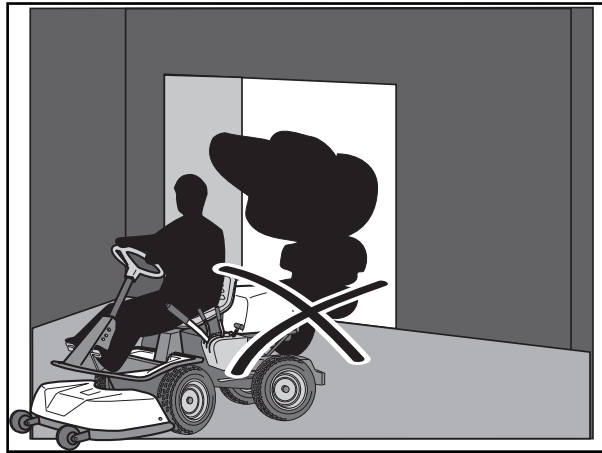

8010-060

*Never drive the machine in an enclosed space.*

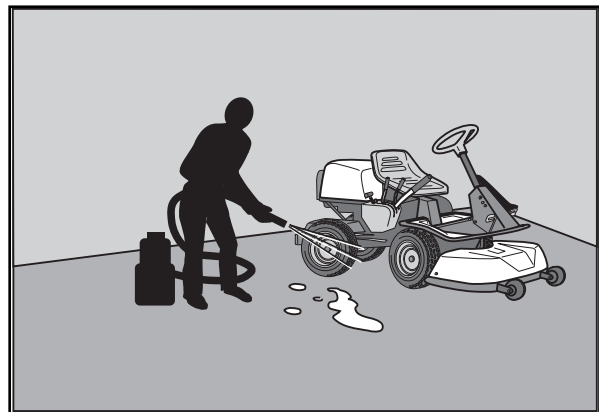

8010-061

*Regularly clean grass, leaves and other debris from the machine.*

### **IMPORTANT INFORMATION**

**The parking brake is not sufficient to lock the machine during transport. Ensure you secure the machine firmly to the transporting vehicle.**

# PRESENTATION

## Presentation

This operator's manual describes the Rider ProFlex 21 II.

The Rider ProFlex 21 II is fitted with a Kawasaki four-stroke V-Twin engine developing 21 horse power.

Power transmission from the engine is via a hydrostatic gearbox that allows variable speed controlled by the foot pedals. One pedal to drive forwards and one pedal to reverse.

The machine is equipped with servo steering and hydraulic lifts, powered by the gearbox.

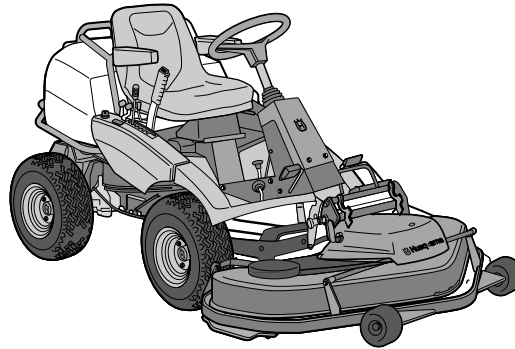

8009-318

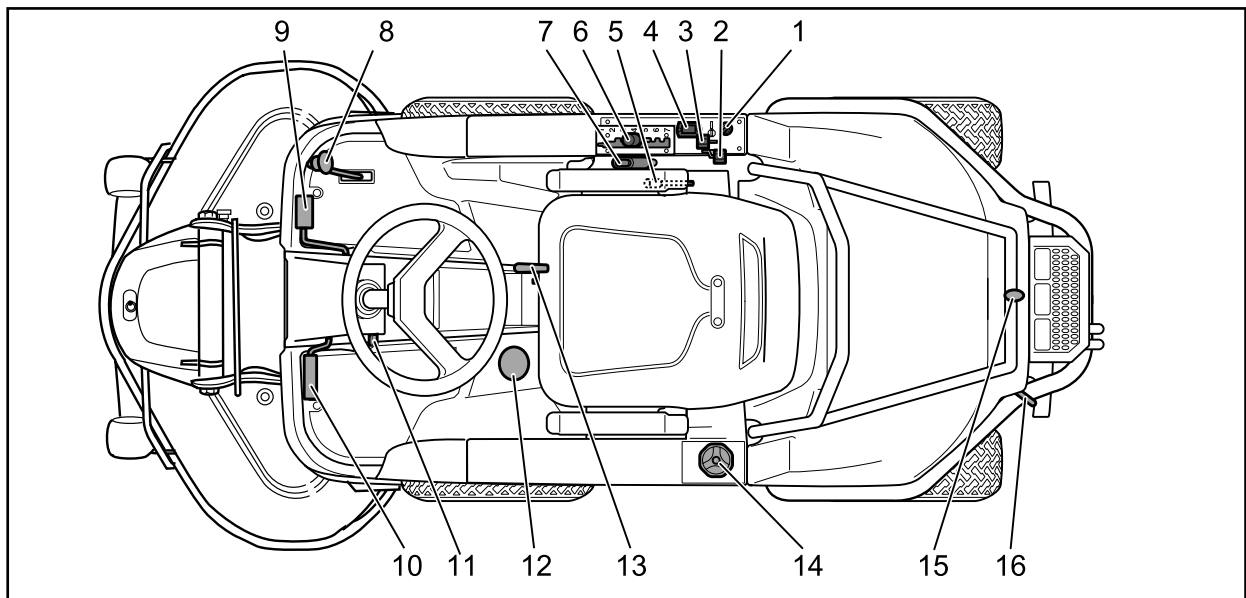

8009-319

## Placement of Controls

- |   |                                     |
|---|-------------------------------------|
| 1. Ignition lock                                      | 9. Accelerator for driving forwards |
| 2. Choke lever  | 10. Parking brake pedal             |
| 3. Throttle control – regulates the engine speed      | 11. Lock button for parking brake   |
| 4. Chronometer  | 12. Differential lock pedal         |
| 5. Hydraulic lifting lever for cutting unit           | 13. Seat adjustment lever           |
| 6. Cutting height adjustment lever                    | 14. Fuel cap                        |
| 7. Mechanical lifting lever with lock button for unit | 15. Cover lock                      |
| 8. Accelerator for reversing                          | 16. Clutch control                  |

# PRESENTATION

## Throttle Control

The throttle is used to control the speed of the engine and thereby also the rotation speed of the blades.

In order to increase or decrease the engine speed, the control is moved forwards or backwards respectively.

Avoid idling the engine for long periods, as there is a risk of carbon build-up on the spark plugs.

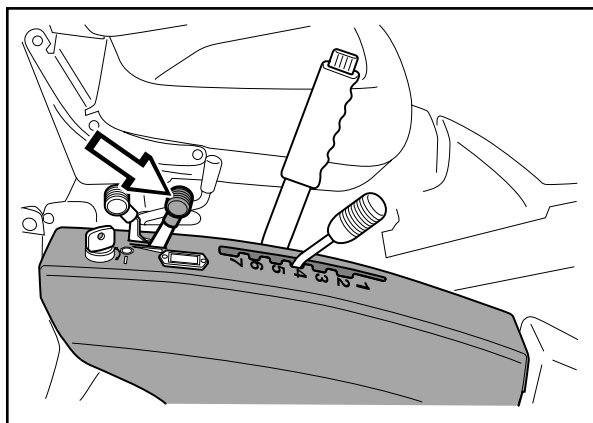

8009-320

## Choke Lever

The choke lever is used for cold starts in order to provide the engine with a richer fuel mixture.

For cold starts, the lever shall be moved backwards to its endpoint.

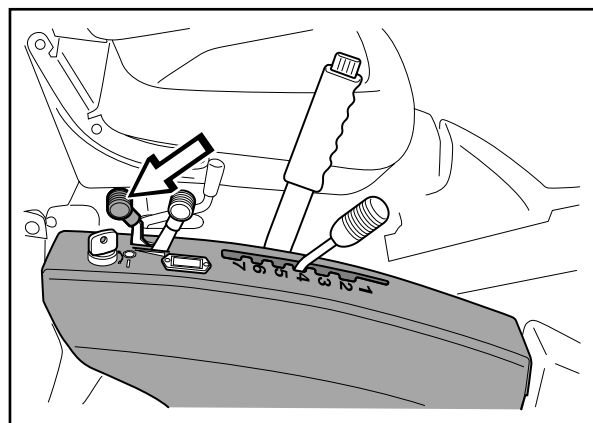

8009-321

## Accelerator

The speed of the machine is variably controlled using two pedals. Pedal (1) is used to travel forwards and pedal (2) to reverse.



### WARNING!

Make sure that no branches can interfere with the pedals when mowing under bushes.

Risk for unintentional manoeuvring.

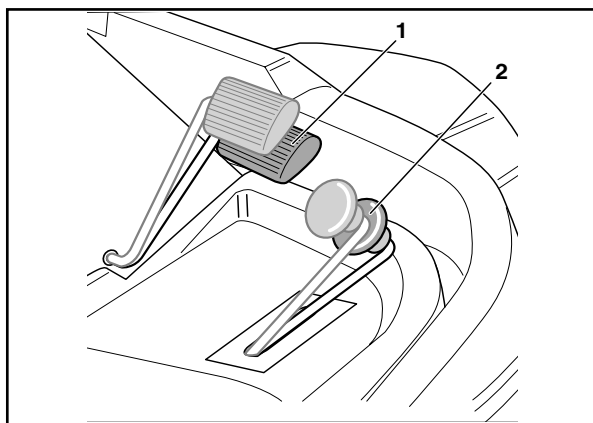

6004-206



---

# PRESENTATION

---

## Cutting Unit

As standard, the Rider ProFlex 21 II is fitted with a Combi 122 cutting unit with a cutting width of 122 cm.

The Combi unit functions as a BioClip unit when a BioClip plug is fitted, but can be set to rear ejection by removing the BioClip plug.

The unit's BioClip function finely chops the grass several times before returning it to the lawn as fertiliser. The rear ejector ejects the clippings behind the unit without finely chopping them.

## Accessories

The accessories are described in separate operator's manuals. Contact your dealer if you require an accessory.

A selection of the available Rider ProFlex 21 II accessories:

- Brush
- Snow Blade
- Wheel Weights
- Snow Chains
- Dutch Hoe
- Edge Trimmer
- Gravel Harrow
- Trailer
- Spreader

## Hydraulic Lifting Lever for the Cutting Unit

The lifting lever is used to put the cutting unit in either the transport or mowing position when hydraulic pressure is available.

In the transport position, the blade brake is automatically activated so that the blades stop within about five seconds.

### Lifting the cutting unit (transport position)

Pull the lever backwards to engage the transport position.

The unit is raised and the blades stop rotating.

Secure the cutting unit if necessary using the mechanical lifting lever.

### Lowering the unit (mowing position)

If the cutting unit is secured in the transport position using the mechanical lifting lever, move the mechanical lifting lever to the cutting position.

Move the hydraulic lifting lever forwards to engage the cutting position. The unit is lowered and the blades begin to rotate.

In order to ensure that the hydraulic cylinder is in the outer position, hold the lever in the forward position for a half to one second.

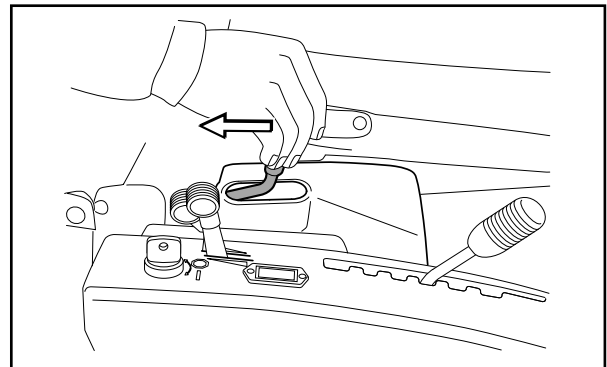

*Raising the cutting unit with the hydraulic lifting lever*

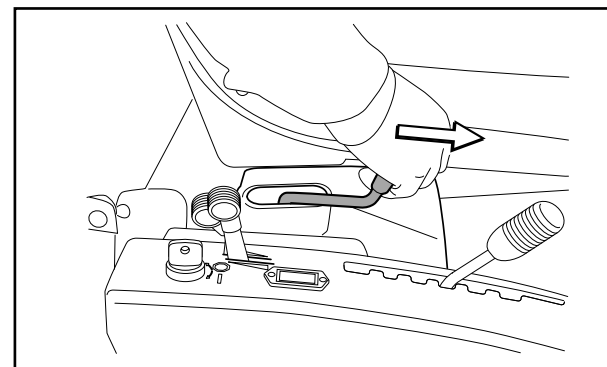

*Lowering the unit with the hydraulic lifting lever*

# PRESENTATION

## Mechanical Lifting Lever for the Cutting Unit

The lever is used as a backup lever to put the cutting unit in either the transport or mowing position when hydraulic pressure is unavailable. It can also be used to mechanically secure the cutting unit in the transport position.

The lever must be used when starting the engine, if the engine stopped with the unit in the mowing position, in order to raise the unit so that the start lock circuit is disengaged.

In the transport position, the blade brake is automatically activated so that the blades stop within about five seconds.

### Transport Position

Pull the lever backwards to the locked position to engage the transport position.

The unit is raised and the blades stop rotating.

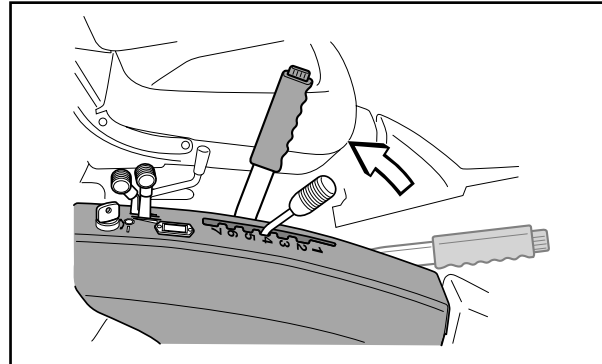

8009-322

*Raising the cutting unit with the mechanical lifting lever*

### Mowing Position

Depress the lock button and move the lever forwards to engage the mowing position.

The unit is lowered and the blades begin to rotate.

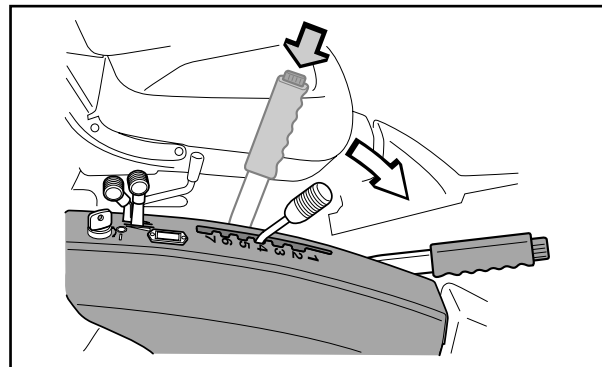

8009-324

*Lowering the unit with the mechanical lifting lever*

# PRESENTATION

## Cutting Height Adjustment Lever

Using the cutting height lever, the cutting height can be adjusted between 7 different positions.

In order to obtain an equal cutting height, it is important that the air pressure is the same in both front wheels (60 kPa).

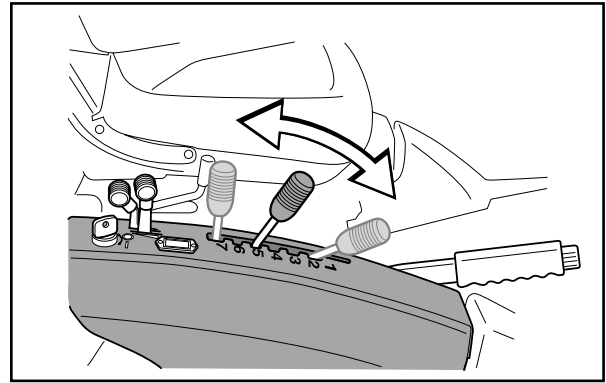

8009-327

## Parking Brake

The parking brake is activated as follows:

1. Press the brake pedal.
2. Completely depress the lock button on the steering servo housing.
3. Release the brake pedal while keeping the button pressed in.

The parking brake lock is automatically disengaged when the brake pedal is pressed down.

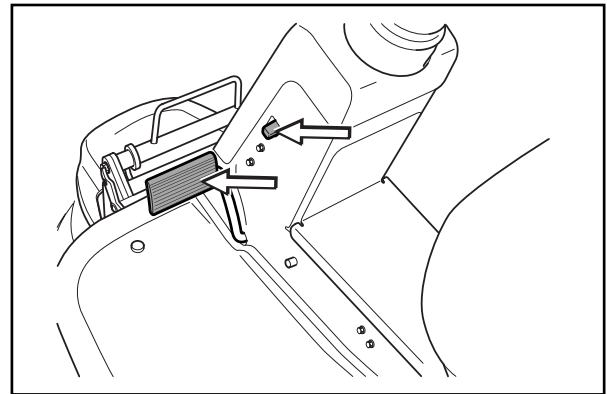

8009-328

## Seat

The seat has a hinged mounting on the front edge and can be folded forwards.

The seat can also be adjusted lengthways.

When making adjustments, the lever under the front edge of the seat is moved to the left, after which the seat can be moved backwards or forwards to the desired position.

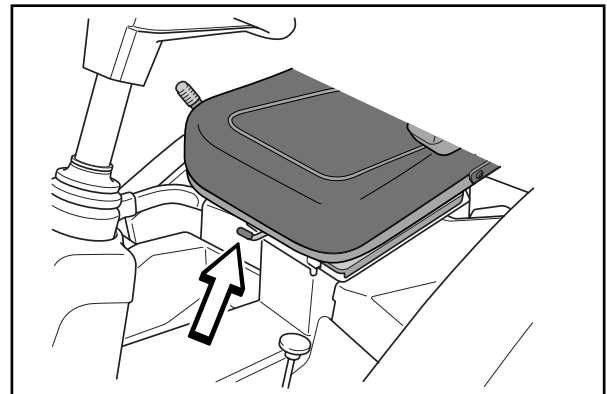

8009-329

## Fuelling

The engine shall be run on a minimum of 87-octane unleaded petrol (no oil mix). It can be beneficial to use environmentally adapted alkylate petrol. See also Technical Data concerning methanol and ethanol fuels.



### WARNING!

**Petrol is highly flammable. Observe caution and fill the tank outdoors (see the safety instructions.)**

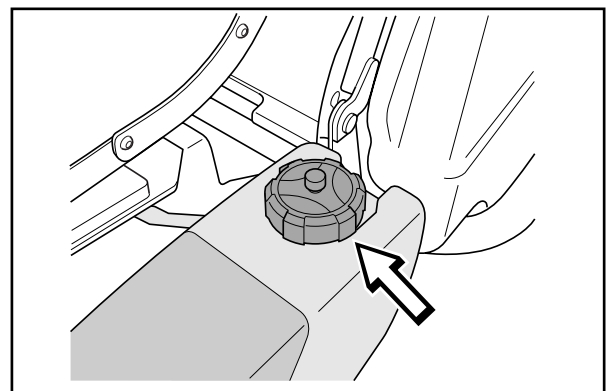

8009-330

# PRESENTATION

## Differential Lock

The differential lock couples the two drive wheels so that one wheel does not spin, thereby improving manoeuvrability.

Press the pedal to engage the differential lock.

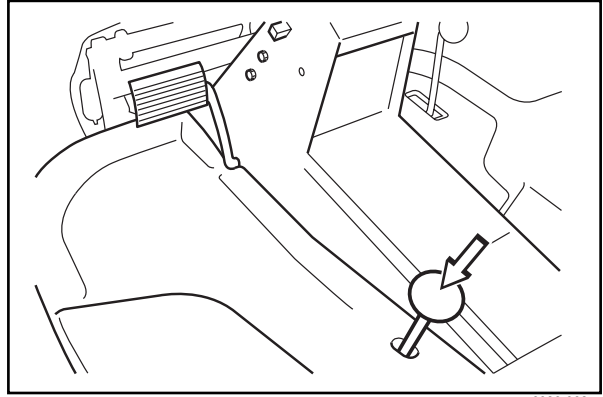

6020-009

## Clutch Control

The clutch control is used to move the rider when the engine is not running.

- Control drawn out, drive system disengaged.
- Control depressed, drive system engaged.

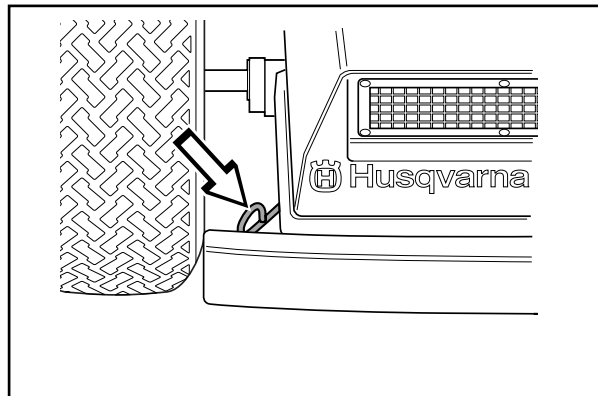

6007-216

## Chronometer

The chronometer shows how many hours the engine has been running. Any time when the engine is not running but the ignition is switched on is not registered. The last digit shows tenths of an hour (6 minutes).

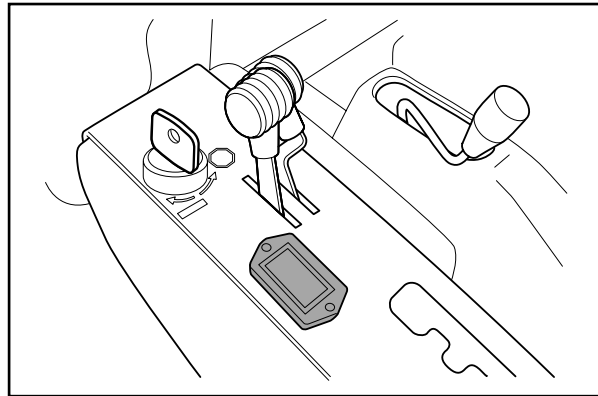

8009-337

# DRIVING

## Driving

### Before Starting

- Read the sections Safety Instructions on page 7 and Presentation on page 13 before starting the Rider.
- Perform the daily maintenance before starting (see Maintenance Schedule on page 25).
- Adjust the seat to the desired position.

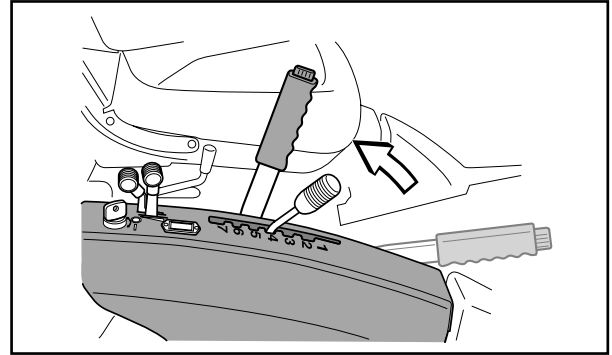

8009-322

### Starting the Engine

1. Raise the cutting unit by pulling the mechanical lifting lever backwards to the locked position (transport position) and apply the parking brake.

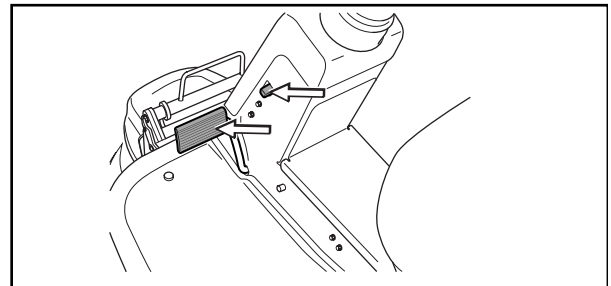

8009-328

2. Move the throttle to the middle position.

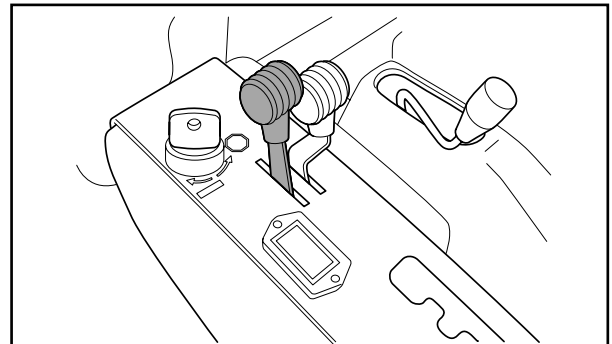

8009-331

3. If the engine is cold, the choke control shall be moved backwards to its end position.

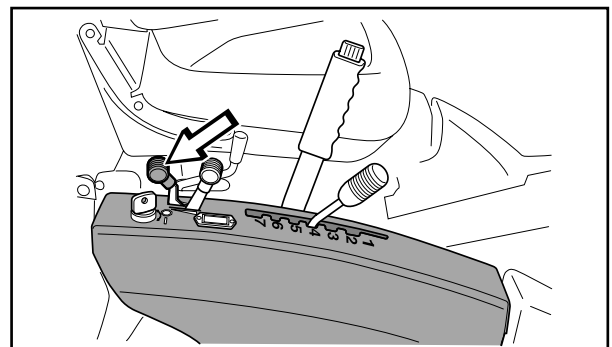

8009-321

4. Turn the ignition key to the start position.

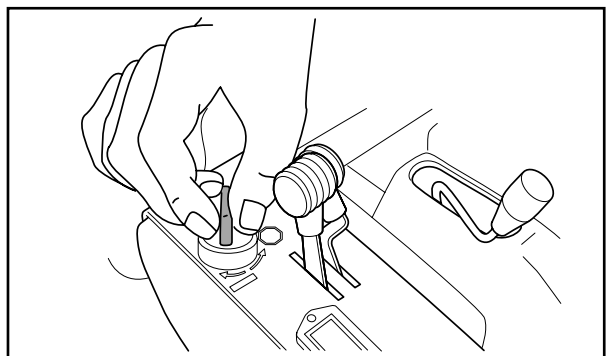

8009-332

# DRIVING

- When the engine starts, immediately release the ignition key so that it returns to the neutral position.

## IMPORTANT INFORMATION

**Do not run the starter motor for more than 5 seconds at a time. If the engine does not start, wait about 15 seconds before trying again.**

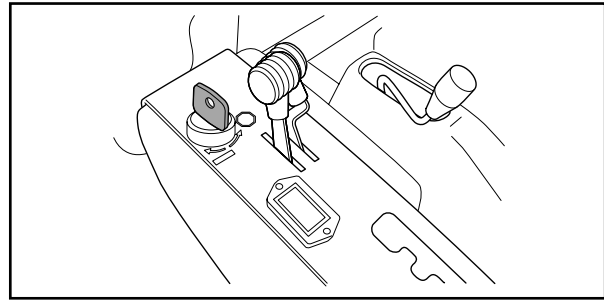

8009-333

- Move the choke lever gradually forward once the engine has started.

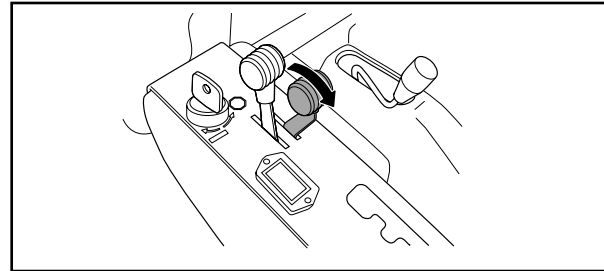

8009-334

- Set the desired engine speed with the throttle. Allow the engine to run at a moderate speed, "half throttle", for 3-5 minutes before loading it too heavily.

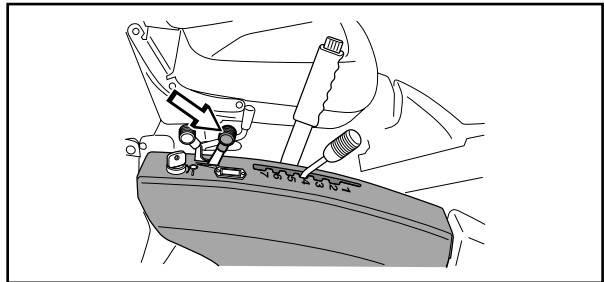

8009-320



## WARNING!

**Never run the engine indoors, in enclosed or badly ventilated areas. Engine exhaust fumes contain poisonous carbon monoxide.**

## Driving the Rider

- Release the parking brake by first pressing the brake pedal and then releasing it.

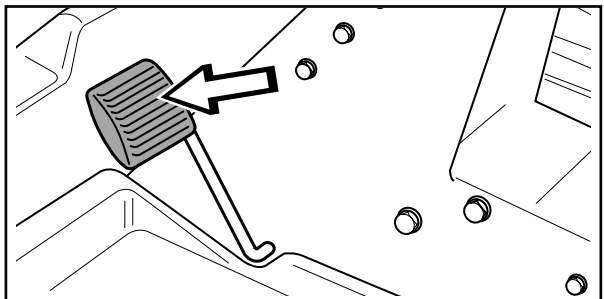

6007-208

- Carefully press down one of the pedals until the required speed is attained. Pedal (1) is pressed down to travel forwards and pedal (2) to reverse.

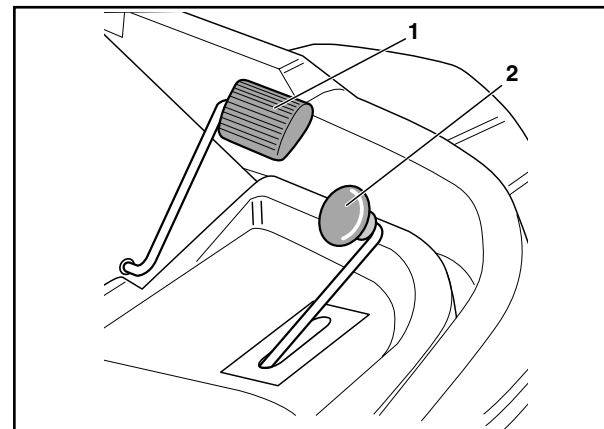

6007-209



## WARNING!

**Never run the engine indoors, in enclosed or badly ventilated areas. Engine exhaust fumes contain poisonous carbon monoxide.**

# DRIVING

3. Select the required cutting height (1-7) using the cutting height lever.

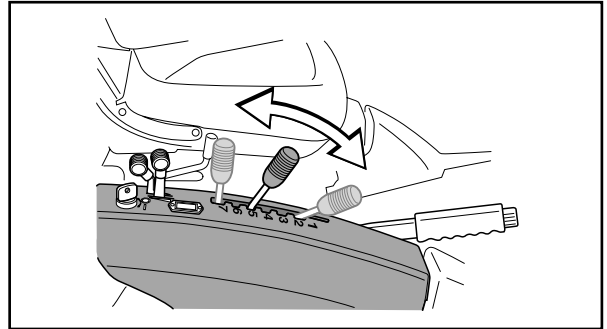

8009-327

4. Depress the lock button on the mechanical lifting lever and move the lever to its most forward position. The cutting unit is lowered and started if the lift hydraulics are in the lower position.

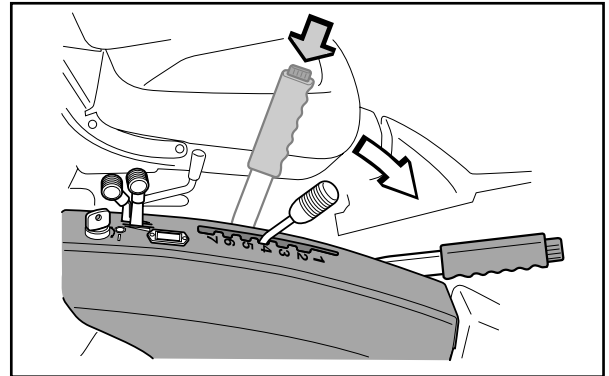

8009-324

5. If the cutting unit does not lower completely, or if the blades do not rotate, lower the cutting unit completely using the hydraulic lifting lever.

In order to ensure that the hydraulic cylinder is in the outer position, hold the lever in the forward position for a half to one second.

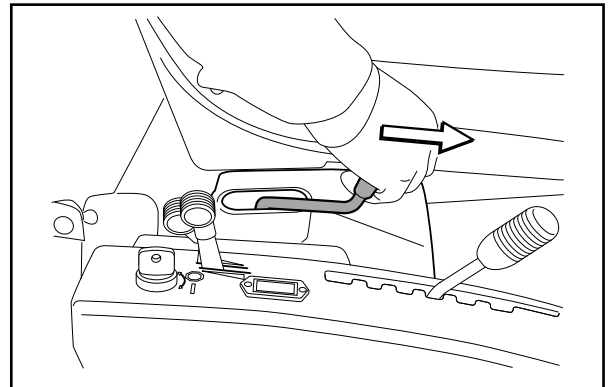

8009-325

## Differential Lock

The differential lock can be used during operation via the pedal on the left side.

In order not to get stuck, one can engage it shortly before the obstacle.

1. Engage the differential lock when necessary by pressing the pedal. If a wheel spins, let the drive pedal up a little.
2. Ensure that the differential lock is disengaged when the pedal is released. Use small steering movements or reverse a little until the pedal returns to its normal position.

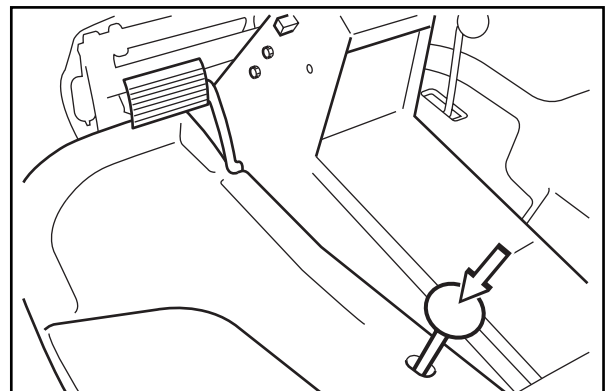

6020-009

# DRIVING

## Mowing Tips



### WARNING!

Clear the lawn of stones and other objects that can be thrown out by the blades.

- Localise and mark rocks and other fixed objects in order to avoid collisions.
- Begin with a high cutting height and reduce it until the desired mowing result is attained.
- The mowing result will be best with a high engine speed (the blades rotate rapidly) and low speed (the Rider moves slowly).

If the grass is not too high and thick, the driving speed can be increased without noticeably depreciating the mowing result.

- The finest lawns are obtained by mowing often. Mowing will be more even and the clippings will be more evenly distributed across the area.

The overall mowing time will not be longer as higher driving speeds can be selected without impairing the mowing result.

- Avoid mowing wet lawns. The mowing result will be poorer as the wheels will sink into the soft lawn.
- Hose beneath the cutting unit with water after each use. When cleaning, the cutting unit shall be moved into the service position.
- When the BioClip unit is used, it is extra important that the mowing interval is not too long.

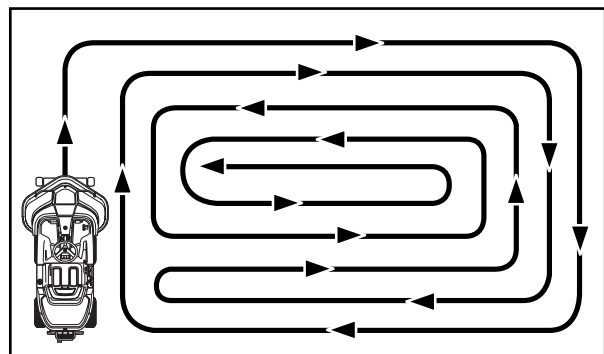

6007-212

Mowing Patterns



### WARNING!

Never drive the Rider on terrain that slopes more than 15°. Mow upwards and downwards on slopes, never sideways. Avoid sudden directional changes.

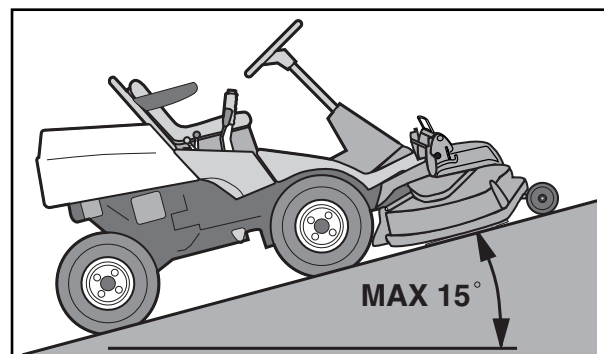

6016-104



# DRIVING

## Stopping the Engine

If the engine has been worked hard, it is preferable to let the engine idle for a minute so it is running at its normal working temperature when it is stopped. Avoid idling the engine for long periods, as there is a risk of carbon build-up on the spark plugs.

1. Lift the cutting unit with the hydraulic lifting lever. The unit can then be secured in the raised position if necessary by moving the mechanical locking lever backwards to the lock position.

If the cutting unit is left in the lower position, the start lock circuit will prevent engine starts.

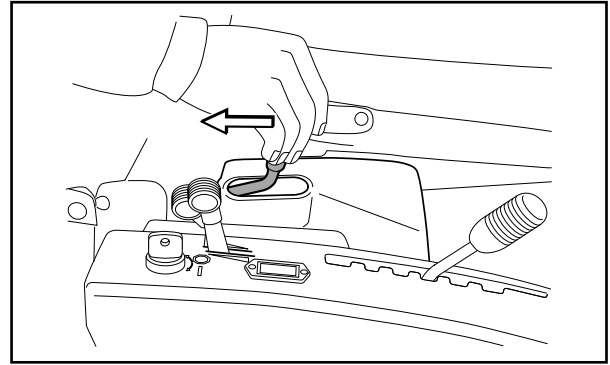

8009-323

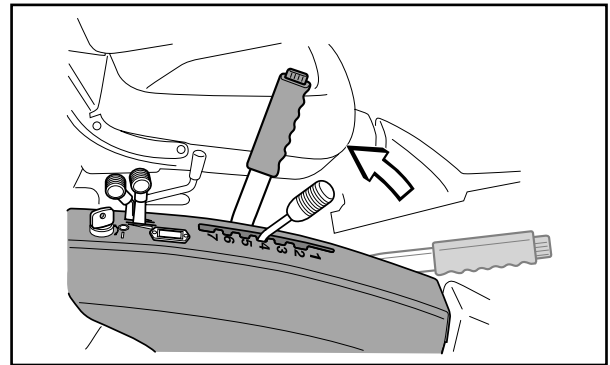

8009-322

2. Move the throttle control to the MIN position. Turn the ignition key to STOP.

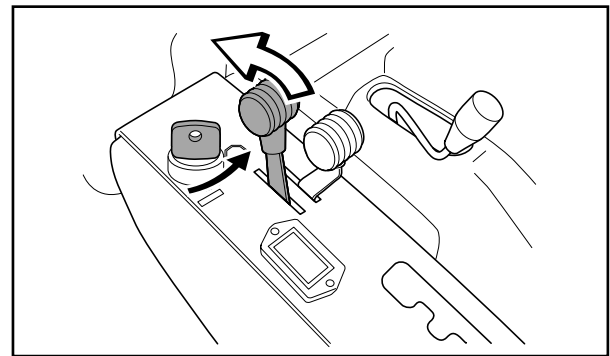

8009-378

3. When the Rider is at a standstill, press down the parking brake and push in the locking button completely.

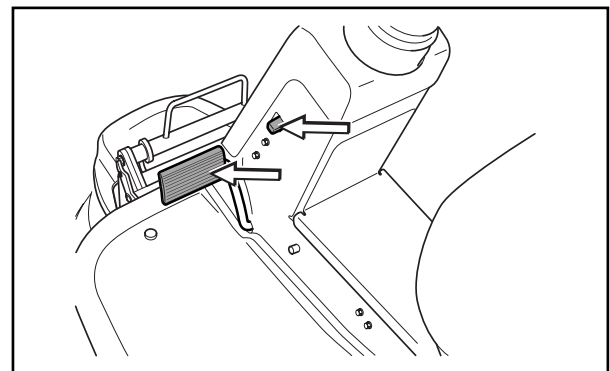

8009-328

---

# DRIVING

---

## Clutch Control

The clutch control must be pulled out in order for the Rider to be moved when the engine is shut off.

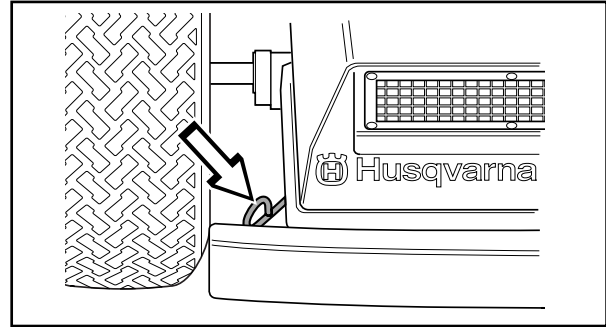

8009-337

# MAINTENANCE

## Maintenance

### Maintenance Schedule

The following is a list of maintenance procedures that must be performed on the Rider. For points marked with footnote number 4, turn to an authorised service representative.

Maintenance	Page	Daily maintenance		Weekly <sup>3</sup> maintenance	At least once a year	Maintenance interval in hours			
		before	after			25	50	100	300
Check for fuel and oil leakages		○							
Check the parking brake	33	●							
Check the engine's oil level (every refuelling)	50	●				●			
Check the fuel pump's air filter	35	●							
Check the safety switch, seat	37	●							
Check the safety switch, lifting lever	37	●							
Check the safety switch, pedal system	37	●							
Check/clean the engine's cooling air intake	29		●			●			
Check the cutting unit:	40		●						
• attaching the blades	42		●						
• condition of the blades (sharpness, shape, etc.)	42		●						
Check the steering cables (looseness, etc.)	30		●						
Check fastenings (screws, nuts, etc.)	-		○						
Start the engine and blades, listen for unusual sounds	19		●						
Clean under the cutting unit	41		●						
Clean the transmission's cooling air intake	29		●			●			
Check the battery's acid level	36			●					
Check the transmission oil level	53			●					
Check the condition of belts, belt pulleys, etc.	-			○					
Check for damage	-			○					
Check the air pressure in the tyres (60 kPa)	33			●					
Check to ensure that the cable guides in the middle are undamaged	32			●					
Clean thoroughly around the engine	-			○					
Clean thoroughly around the transmission	-			○					
Clean around all belts, belt pulleys, etc.	48			●					
Lubricate the differential lock cable	49			●					
Lubricate the three-point link (nipple)	51			●					
Lubricate the driver seat	51			●					
Lubricate all cables	48			●					
Lubricate the safety catch in the cutting unit	51			●					
Lubricate the interior plug in the cutting unit	51			●					
Lubricate the groove for the cutting unit's equipment frame	51			●					
Lubricate links in the cutting unit	51			●					
Clean the frame tunnel	-			○					
Lubricate the pedal mechanism in the frame tunnel	48			●					

# MAINTENANCE

Maintenance	Page	Daily maintenance		Weekly <sup>3</sup> maintenance	At least once a year	Maintenance interval in hours			
		before	after			25	50	100	300
Lubricate the gear controller	50			●					
Lubricate the parking brake cable	52			●					
Lubricate the throttle	51			●					
Lubricate the choke control	51			●					
Lubricate the guide chain in the frame tunnel	49			●					
Check the steering cables in the frame tunnel	30			●					
Clean the engine's cooling air intake	29				●	●			
Clean the air cleaner's pre-filter (Oil-foam)	34				●	●			
Change the engine oil <sup>1)</sup>	49				●			●	
Clean the air cleaner's filter cartridge <sup>2)</sup> (paper filter)	34				●		●		
Check/adjust the cutting height	40				●		●		
Check/adjust the parking brake	33				●		●		
Inspect the flame proofing/spark extinguisher (extra equipment)	-				○		○		
Replace the hydraulic oil filter (every 200 hours)	52				●			●	
Replace the engine oil filter (every 200 hours)	52				●			●	
Clean/replace the spark plugs	36				●			●	
Change the inline fuel filter	35				●			●	
Clean the pulse air filter	35				●			●	
Clean the cooling fins	-				○			○	
Check the play in the engine valves <sup>4)</sup>	-				○				○
Check to see if the oil needs changing <sup>4)</sup> or the filter needs changing <sup>4)</sup> in the gear box (every 500 hours)	-				○			○	
Replace the air cleaner's pre-filter (Oil-foam) <sup>2)</sup>	34				●				●
Replace the air filter (paper filter) <sup>2)</sup> (every 200 hours)	34				●			●	
Perform the 300-hour service <sup>4)</sup>	69				○				○

1) First change after 8 hours. When operating with a heavy load or at high ambient temperatures, replace every 50 hours. 2) Maintenance and replacement are required more often in dusty conditions. 3) The Rider should be lubricated twice weekly with daily use. 4) Performed by authorised service representative.

● = Described in this manual.

○ = Not described in this manual.



## WARNING!

**No service operations may be performed on the engine or cutting unit unless:**

- **The engine has stopped.**
- **The parking brake is on.**
- **The ignition key has been removed.**
- **The cutting unit is disengaged.**
- **The ignition cables have been removed from the spark plugs.**

# MAINTENANCE

## Removing the Rider's Covers

### The Engine Cover

1. Tilt the seat back.
2. Turn the cover lock on the engine cover exterior counter-clockwise 1/4 turn.
3. Fold up the engine cover.

If needed, the engine cover can be lifted off by removing the hinge pins.

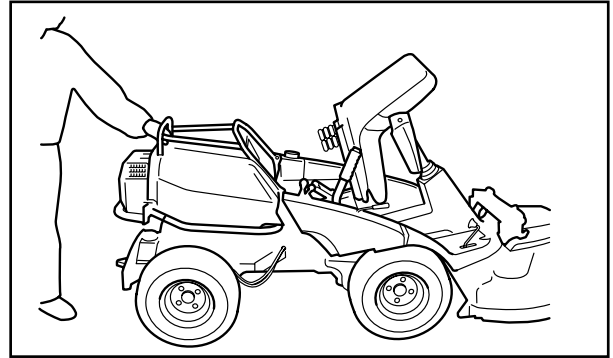

8009-338

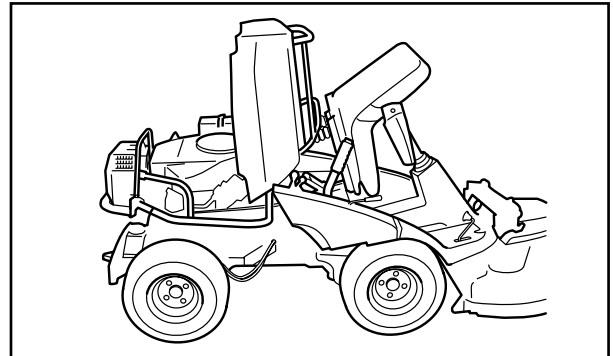

8009-339

### The Nose Cover

Remove the quick lock and lift off the nose cover.

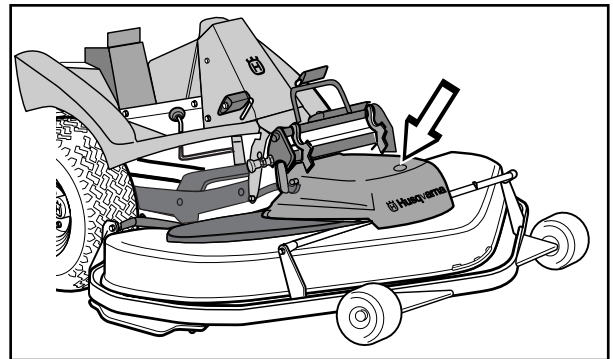

6016-106

### The Right-hand Wing Cover

Remove the accelerator knob (1), screws (2 and 3), and remove the wing cover.

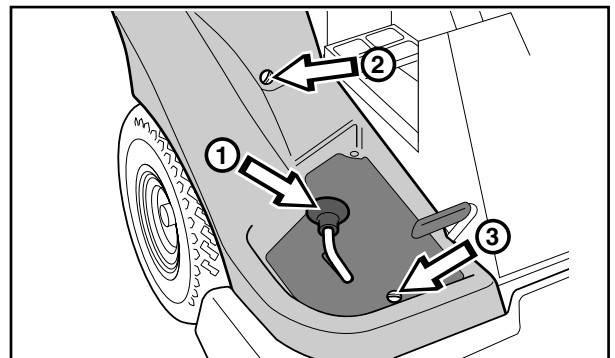

6008-203

# MAINTENANCE

## Left-hand Wing Cover

Remove the differential lock pedal knob.  
Loosen the screws (1 and 2) and remove the wing cover.

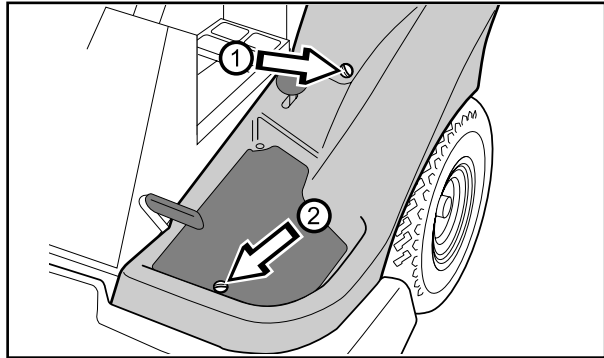

6020-008

## Transmission Cover

Loosen both screws (one on each side) and lift off the transmission cover.

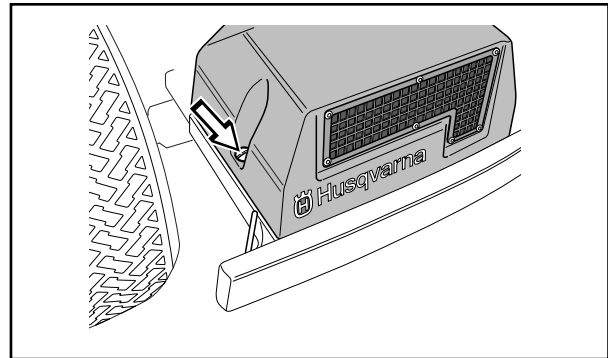

6008-209

## Checking the Engine's Cooling Air Intake

Open the engine cover.

Check that the engine cooling air intake is free of leaves, grass, and dirt.

A clogged cooling air intake impairs the cooling of the engine, which may result in engine damage.

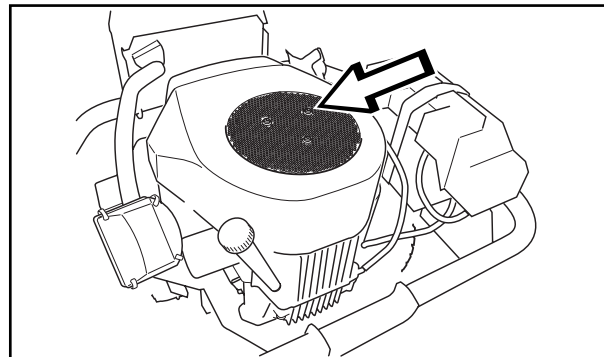

8009-152

## Checking the Transmission Air Intake

Check to ensure that the air intake valve to the transmission is not clogged.

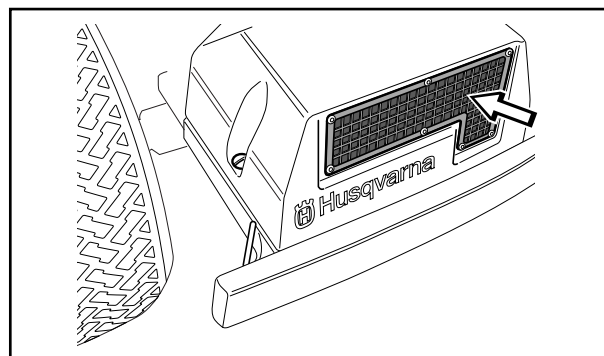

6008-208

# MAINTENANCE

## Checking and Adjusting the Steering Cables

The steering is governed by means of cables.

After a period of use these can become stretched, which means the steering setting may have changed.

Steering is checked and adjusted as follows:

1. Remove the frame plate by loosening the screws (two on the steering servo housing).

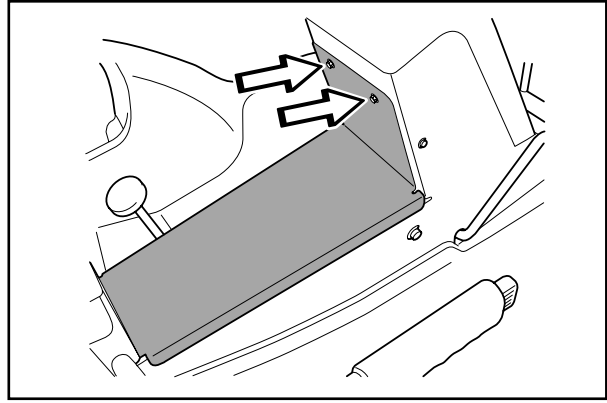

8009-340

2. Ensure that the cables are properly situated under the steering cable pulleys in the frame tunnel.

Check the tension of the steering cables by squeezing the cables together (at the arrows). It should be possible to squeeze the cables so that the distance between them is half the size, without using too much force.

Change the cable if it has a damaged strand causing loose threads to protrude.

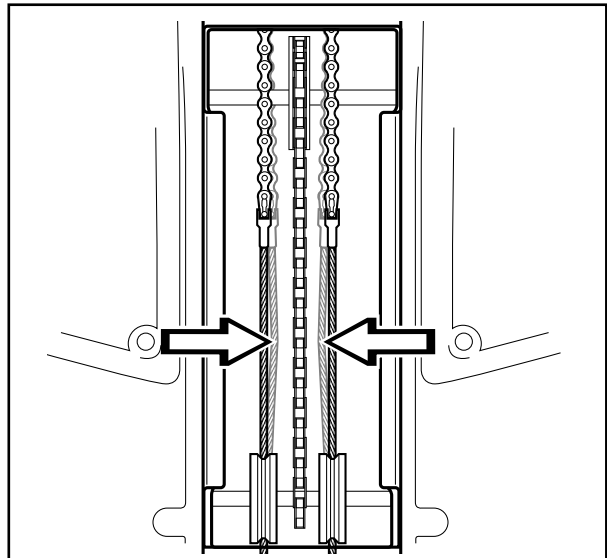

6008-212

3. If necessary, the cables can be stretched by first loosening the lock nut and then tightening the adjuster nuts (one cable on each side of the machine).

Hold the cable with, for example, a wrench so that it does not twist. If the adjustment is only made on one side, the middle position of the steering will be affected.

Do not over tighten the cables, they should only be drawn in towards the steering collar.

Check the cable tension after you have made the adjustment as described in point 2.

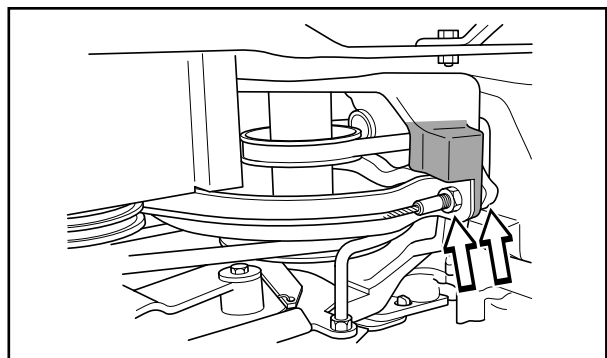

8009-341

# MAINTENANCE

## Checking and Adjusting the Throttle Cable

Check that the engine responds to throttle increases and that a good engine speed is attained at full throttle.

If doubts arise, contact your service representative.

If adjustments are necessary, they can be made as follows for the lower cable:

1. Loosen the clamping screw for the cable's outer casing and move the throttle to the full throttle position.
2. Check that the throttle cable is mounted in the correct hole in the lower lever, see illustration.
3. Push the throttle cable outer casing as far to the left as possible and tighten the clamping screw.

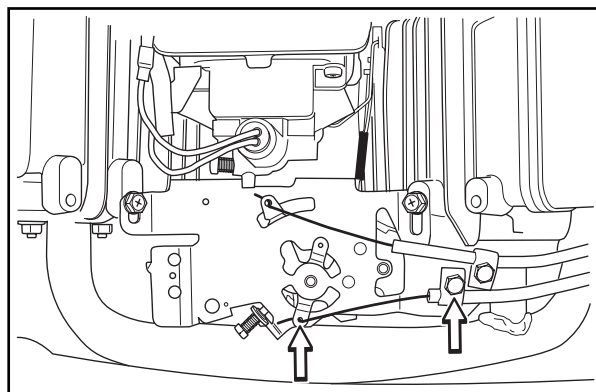

8009-176

## Checking and Adjusting the Choke Cable

If the engine produces black smoke or is difficult to start, this can be because the choke cable is incorrectly adjusted (upper cable).

If doubts arise, contact your service representative.

If adjustments are necessary, they can be made as follows:

1. Loosen the clamping screw for the cable's outer casing and move the choke lever to the full choke position.
2. Check that the choke cable is mounted in the upper lever, see illustration.
3. Pull the choke cable outer casing as far to the right as possible and tighten the clamping screw.

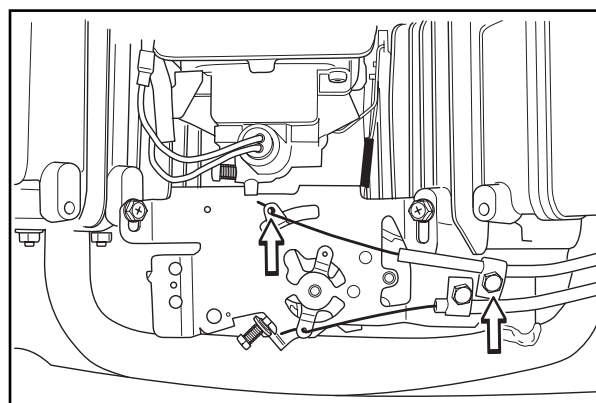

8009-177

## Adjusting of the Differential Lock

The differential lock (on the left side) is adjusted in the following manner:

1. Check that the differential lock is disengaged; the pedal should be all the way up.
2. Adjust the zero play between the cable casing and the adjustment screw with the two nuts on the adjustment screw. You should feel no play when you pull the casing.
3. Tighten the nuts moderately to avoid damaging the threads.

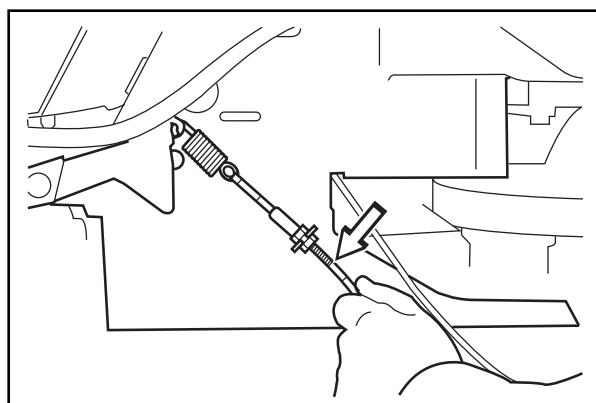

6020-011



# MAINTENANCE

## Adjusting of the Hydrostatic Transmission Cable

The hydrostatic transmission cable (on the left side) is adjusted in the following manner:

1. Remove the transmission cover. Loosen both screws (one on each side) and lift off the transmission cover.
2. Take apart the lower ball joint, which is locked with a spring lock.
3. Ensure that the forward drive pedal is pressed down completely.
4. Switch the vertical arm to the maximum position and check that the ball and socket in the lower ball joint are aligned.
5. Adjust the socket on the cable if needed.
6. Assemble the lower ball joint.
7. Put the ball joint's spring lock in place.

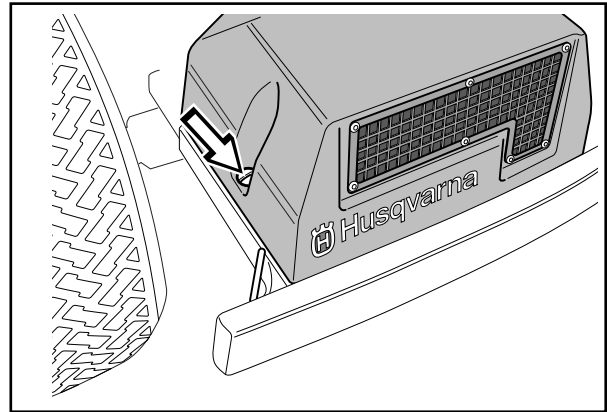

6008-209

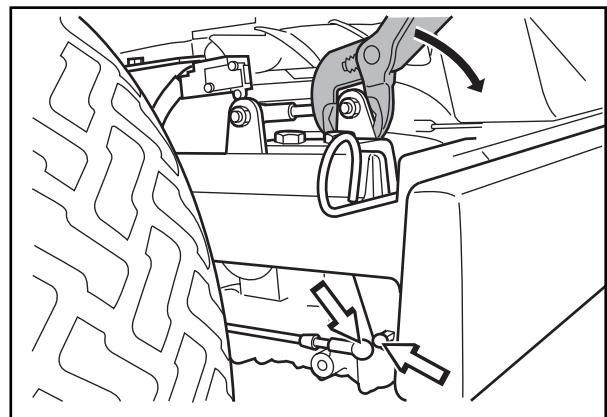

6020-002

## Cable Seat

The cable seat in the middle protects the cables and the hydraulic tubes so that they do not get pinched during turns. It is situated close to the ground and can be damaged by objects or careless driving, especially when reversing.

Check to ensure that it is undamaged and that the belt guide is properly centred on the rear side of the pulley.

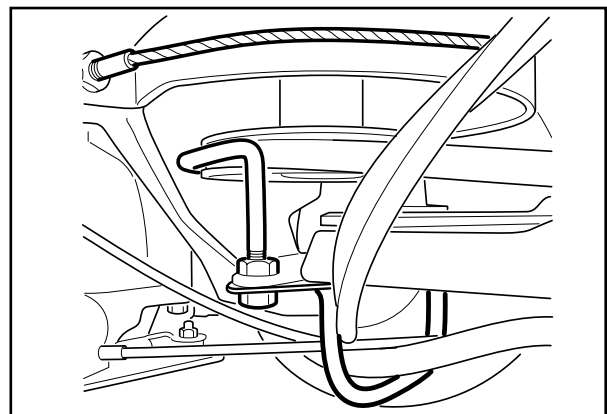

6012-364

# MAINTENANCE

## Adjusting the Brake

The parking brake (on the right side) is adjusted in the following manner:

1. Remove the transmission cover. Loosen both screws (one on each side) and lift off the transmission cover.
2. Unhook the spring (A) from the screw (B).

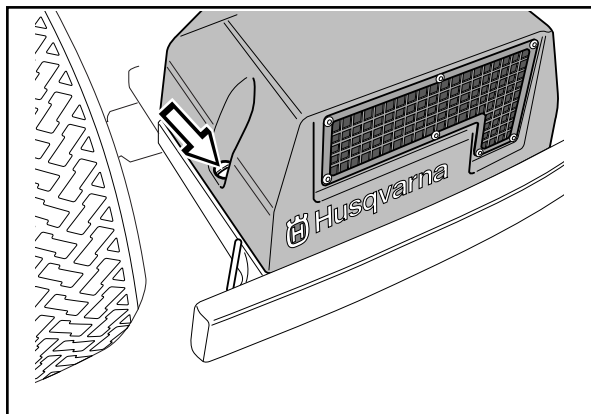

6008-209

3. Check that the parking brake is not engaged.
4. Adjust the play between the casing and the adjustment screw to 1 mm when one pulls the casing. Adjust with the nuts on the adjustment screw.
5. Tighten the nuts moderately to avoid damaging the threads.
6. Replace the spring (A).
7. Test the brake to ensure that it works.

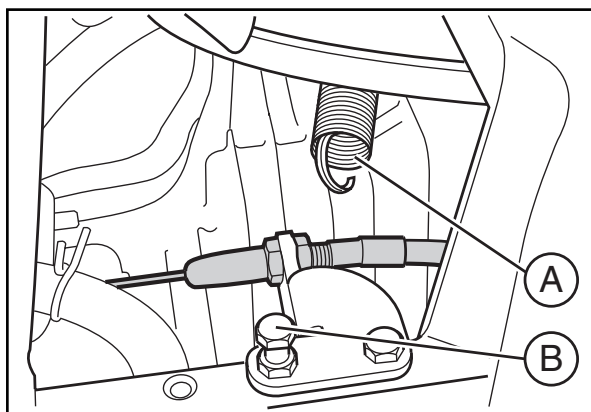

6020-005



### WARNING!

A poorly adjusted brake can result in reduced braking ability.

## Checking the Tyre Pressures

The tyre's air pressure should be 60 kPa (0.6 kp/cm<sup>2</sup>) on all wheels.

In order to improve drive power the pressure in the rear tyres can be reduced to 40 kPa (0.4 kp/cm<sup>2</sup>).

The highest permitted pressure is 80 kPa (0.8 kp/cm<sup>2</sup>).

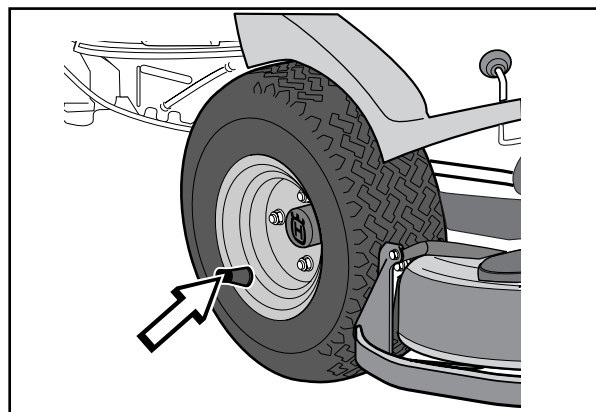

6016-109

### IMPORTANT INFORMATION

Different air pressure in the front tyres will result in the blades mowing the grass at different heights.

# MAINTENANCE

## Replacing the Air Filter

If the engine seems to lack power or does not run smoothly this may be because the air filter is clogged. If run with a soiled air filter, carbon can build-up on the spark plugs and lead to malfunction.

For this reason, it is important to replace the air filter regularly (see Maintenance Schedule on page 25 for the proper service interval).

Cleaning/replacement of the air filter is carried out as follows:



### WARNING!

**Allow the exhaust system to cool before performing service.  
Risk for burns.**

1. Fold up the engine cover.
2. Remove the two plastic fasteners on the top of the air filter cover and remove the air filter cover.
3. Remove the foam rubber pre-filter and clean using a mild detergent.

Squeeze it dry with a clean cloth.

4. Remove the wing nuts for the air filter and remove the paper filter. Tap the paper filter against a fixed surface to remove dust. If the paper filter is still dirty, it must be replaced.

### IMPORTANT INFORMATION

**Do not use compressed air to clean the paper filter.**

**Do not wash the paper filter.**

**Do not oil the paper filter.**

5. Refit the air filter as follows:  
Check that the seal on the bottom of the paper filter is whole. Mount the paper filter in the air filter housing and tighten the wing nuts.
6. Refit the pre-filter on the paper filter.
7. Replace the cover over the air filter housing. Do not over tighten the plastic fasteners.

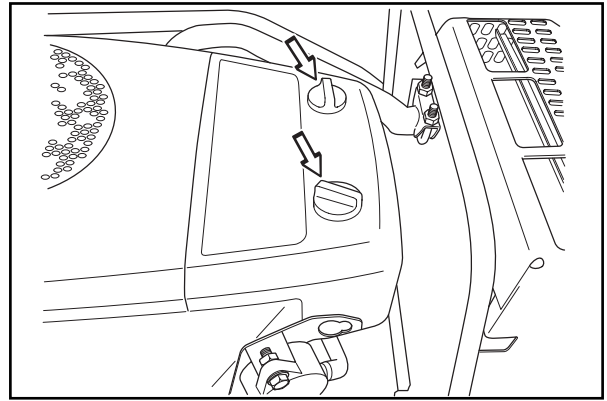

8009-179

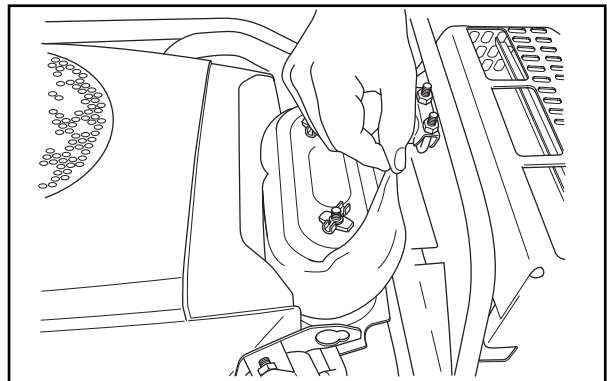

8009-180

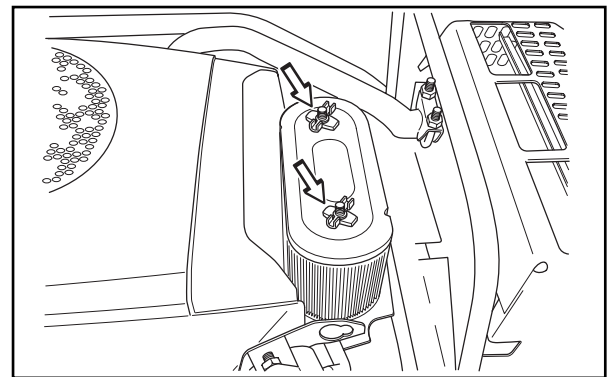

8009-182

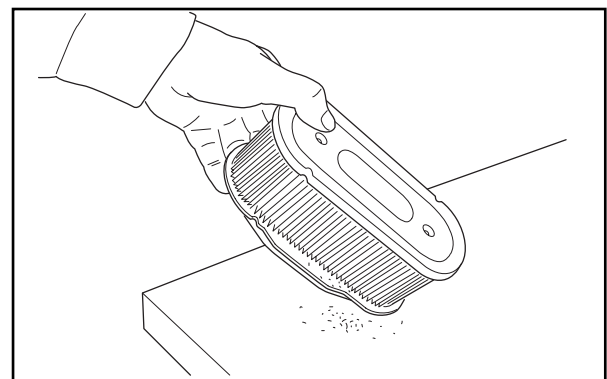

8009-181

# MAINTENANCE

## Replacing the Fuel Filter

Replace the fuel filter mounted on the supply line after every 100 hours (once per season) or more frequently if it is clogged.

Replace the filter as follows:

1. Open the engine cover.
2. Move the hose clamps away from the filter. Use a pair of flat pliers.
3. Pull the filter loose from the hose ends.
4. Push the new filter into the hose ends. Position the filter with the FLOW arrow pointing up toward the fuel pump. If necessary, a soap solution can be applied to the ends of the filter to simplify assembly.
5. Move the hose clamps back toward the filter.

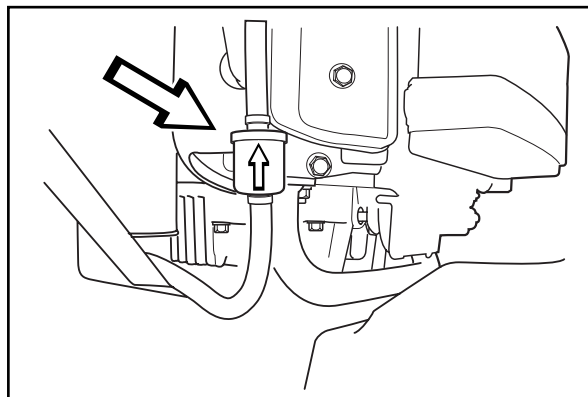

8009-146

## Cleaning the Pulse Air Filter

1. Open the engine cover.
2. Loosen the four snap catches, remove the cover, and remove the filter.
3. Blow the filter clean with pressurised air.
4. Place the filter back in the cover and fasten the cover with the snap catches. Close the engine cover.

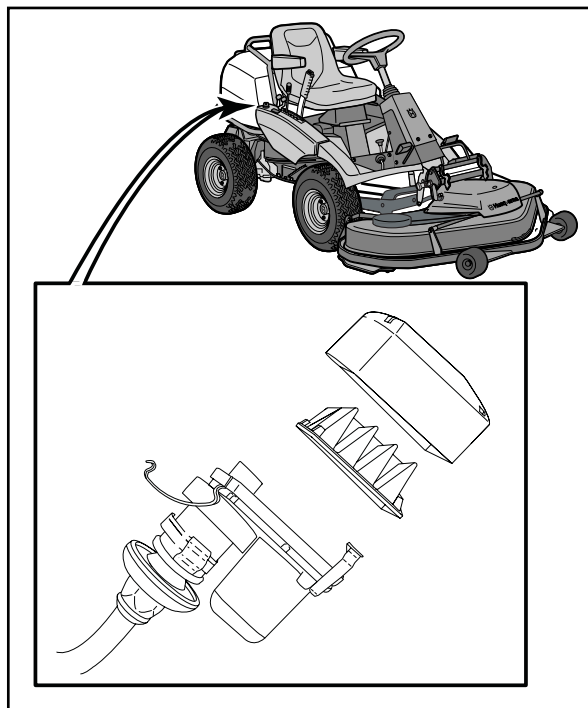

8009-342

## Checking the Fuel Pump's Air Filter

Check regularly that the fuel pump's air filter is not clogged by dirt.

Remove the screws and open the pump, no hoses need be removed.

The filter can be cleaned using a brush, if necessary.

Replace the pump on the console.

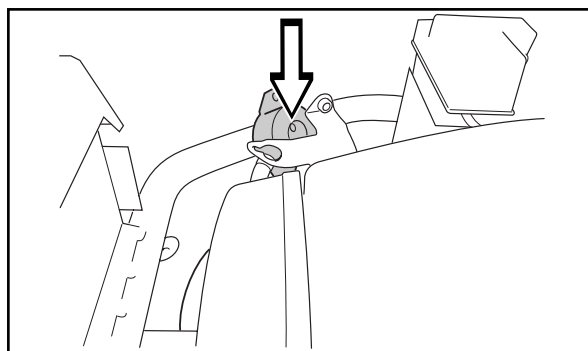

8009-147

# MAINTENANCE

## Checking the Battery Acid Level

Check that the acid level in the battery lies between the markings. When refilling, only distilled water may be used to fill the cells.



### WARNING!

#### What to do in case of contact with battery acid

External: Rinse thoroughly with water.

Internal: Drink large quantities of water or milk. See a doctor as soon as possible.

Eyes: Rinse thoroughly with water. See a doctor as soon as possible.

**The battery emits explosive gases. Sparks, flames, and cigarettes must not be present in the vicinity of the battery.**

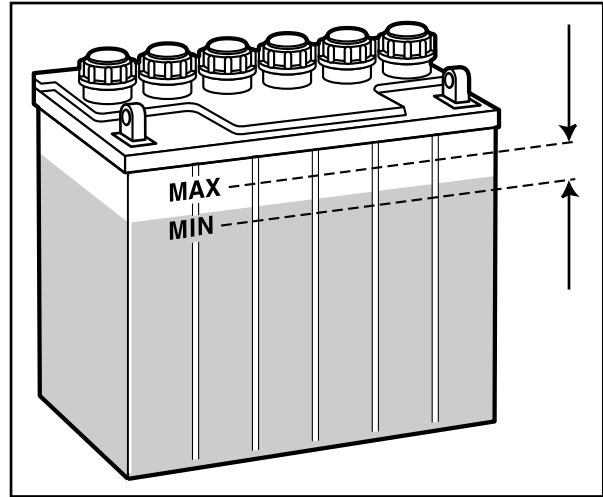

6008-216

## Ignition System

The engine is equipped with an electronic ignition system. Only the spark plugs require maintenance.

For recommended spark plugs, see Electrical system on page 61.

### IMPORTANT INFORMATION

**The wrong spark plug type can damage the engine.**

1. Remove the ignition cable shoe and clean around the spark plug.
2. Remove the spark plug with a 13/16" (21 mm) spark plug socket wrench.
3. Check the spark plug. Replace the spark plug if the electrodes are burned or if the insulation is cracked or damaged. Clean the spark plug with a wire brush if it is to be reused.
4. Measure the electrode gap with a gapping tool. The gap shall be 0.75 mm/ 0.030". Adjust as necessary by bending the side electrode.
5. Reinsert the spark plug, turning by hand to avoid damaging the threads.

### IMPORTANT INFORMATION

**Inadequately tightened spark plugs can cause overheating and damage the engine. Tightening the spark plug too much can damage the threads in the cylinder head.**

6. After the spark plug is seated, tighten it using a spark plug wrench so that the washer is compressed. A used spark plug should be turned 1/8-1/4 of a turn from the seated position. A new spark plug should be turned 1/2 a turn from the seated position.
7. Replace the ignition cable shoe.

# MAINTENANCE

## Main Fuse

The fuse is placed in a detachable holder under the battery case's lid, in front of the battery.

Type: Flat pin, 15 A

Do not use any other type of fuse when changing.

A blown fuse needs to be replaced. Pull the fuse from the holder when changing.

The fuse is there to protect the electrical system. If it blows again shortly after the change, it is due to a short circuit, which must be remedied before the machine can be put into operation again.

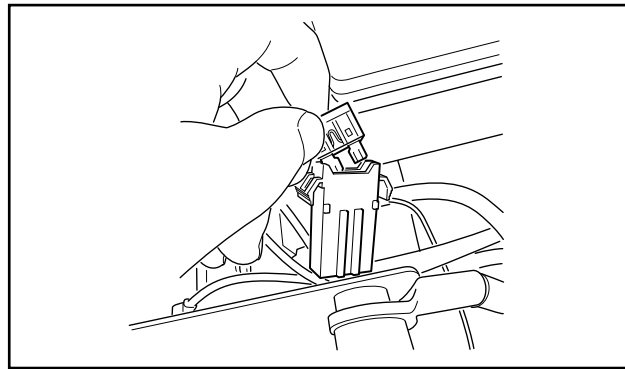

Main fuse

8009-370

## Checking the Safety System

The Rider is equipped with a safety system that prevents starting or driving under the following conditions. The engine should only be possible to start when the cutting unit is in its raised position and the hydrostat pedals are in the neutral position.

The driver does not need to be seated in the driver's seat.

Make daily inspections to ensure that the safety system works by attempting to start the engine when one of the conditions is not met. Change the conditions and try again.

Check that the engine stops if you temporarily move out of the driver's seat while the cutting unit is lowered or the hydrostat pedals are not in the neutral position.

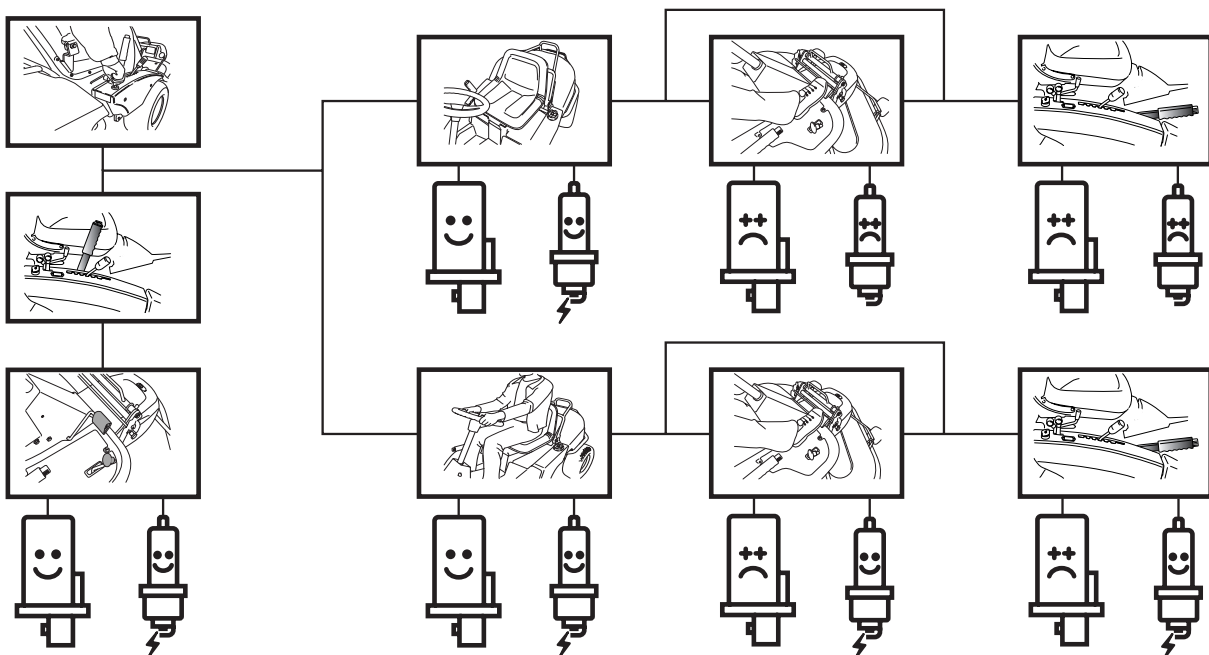
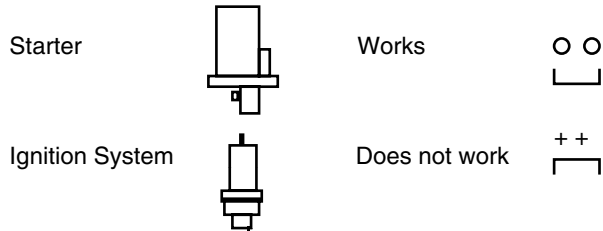

8009-153

# MAINTENANCE

## The Cutting Unit Components

In the instructions below, a cutting unit with a rear ejector is shown, but the same principles apply to all cutting units unless otherwise stated.

The components mentioned are:

- A. Catch.
- B. Interior plug
- C. Safety catch
- D. Handle
- E. Height adjustment handle
- F. Parallelism handle
- G. Lowest height adjustment stop

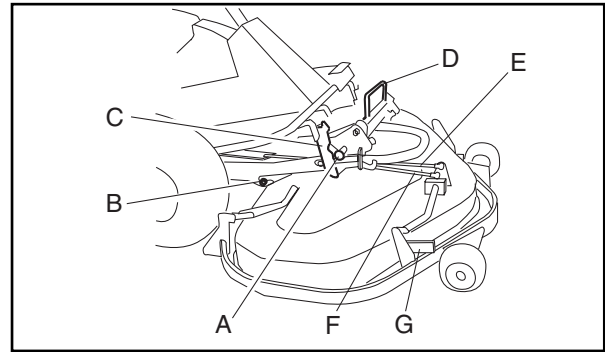

8009-188

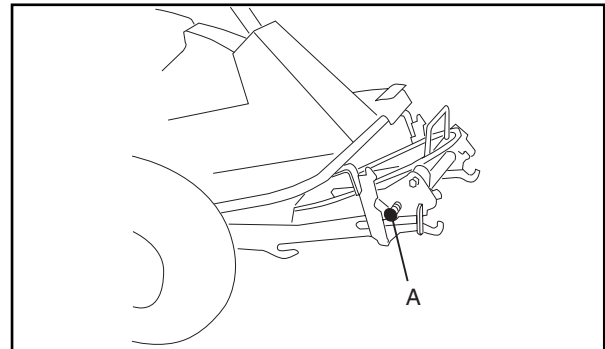

8009-022

## Attaching the Cutting Unit



**WARNING!**  
**Exercise caution.**  
**Risk of crush injuries**

Starting point for attaching the cutting unit:

- Place the machine on a flat surface.
- Lock the brakes by pressing down the pedal and locking with the push-button.
- Equipment hydraulics in the lower position.
- Equipment frame in lowered position.
- Equipment frame locked with safety catch and catches (A) in the set position.
- Unit frame mounted on the cutting unit, see Removing the Cutting Unit Frame on page 45.

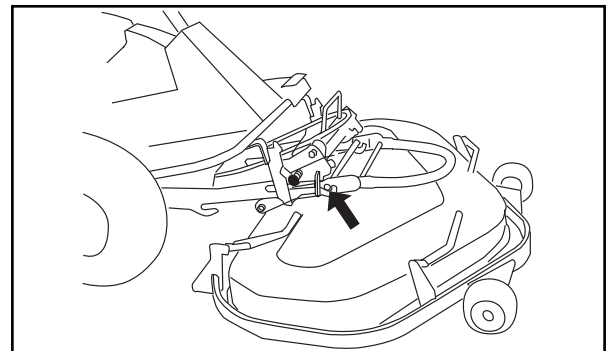

8009-024

1. Attach the unit to the equipment frame's outer hooks.
2. Pull out the catch (A) and loosen the safety catch by pushing its handle (D) back.
3. Raise the unit by pulling up on the mechanical lifting lever, located on the driver's right side.

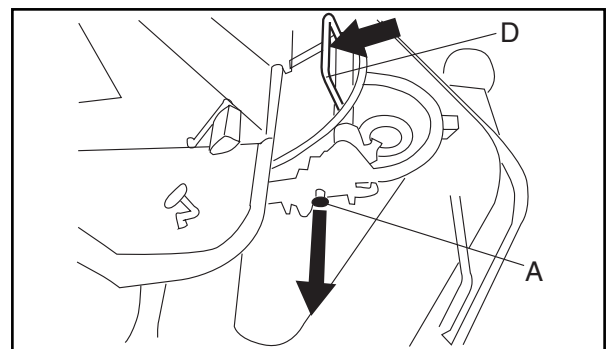

8009-167

# MAINTENANCE

4. Push the unit in so that the interior plugs (B) touch the bottom of the equipment frame's grooves.

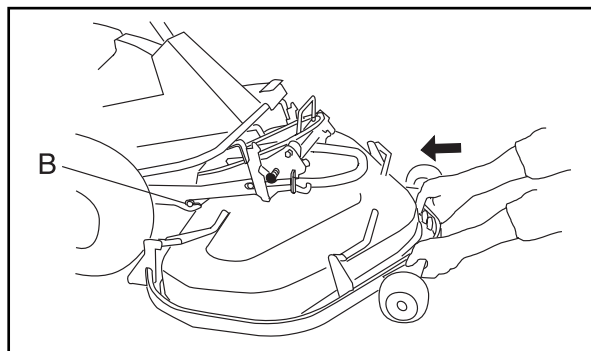

8009-018

5. Hook in the height adjustment handle's (E) rear fastener:

Move the cutting height lever to the forward position. Loosen the stay by pulling the frame's forward section up or down.

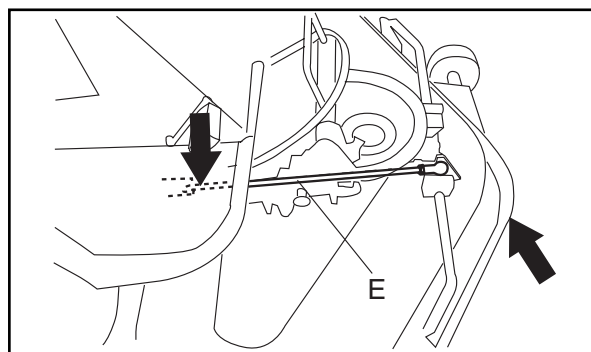

8009-168



## WARNING!

Watch your fingers. Do not turn the blades or the belt.

6. Loosen the belt tension spring and attach the belt to the front belt pulley. A new belt is short. Turn the forward pulley as needed with a spanner on the central bolt.
7. Re-attach the belt tension spring.

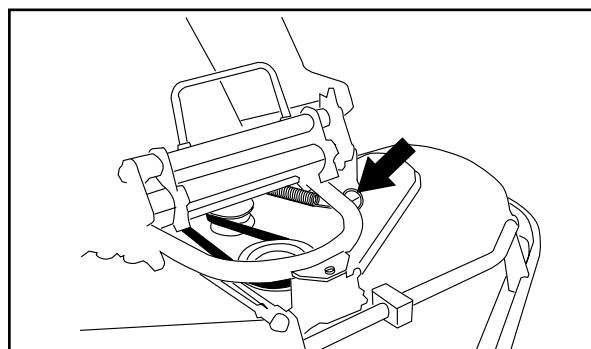

8009-008

## IMPORTANT INFORMATION

Check that the belt is around the idler.

### Belt Sketch

- 1. Drive belt
- 2. Forward pulley
- 3. Belt idler
- 4. Belt tension spring

8. Attach the nose cover.

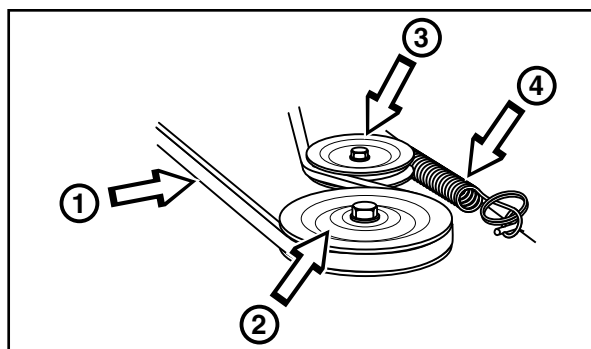

6016-105



# MAINTENANCE

## Adjusting the Unit's Parallelism and Cutting Height

The base machine is adjusted at the factory. When a new cutting unit is attached, you need to adjust the parallelism and cutting height.

Starting position:

1. Check the air pressure in the tyres  
60 kPa (0.6 bar).
2. The cutting unit shall be lowered onto a flat surface.
3. The height adjustment lever shall be set to the lowest cutting height.

### Parallelism

Always start by adjusting the parallelism.

1. Loosen the two nuts on the stay.
2. Measure the distance between the ground and the front and back edges of the unit's cover.
3. Place a spanner over the bevel in the middle of the stay and tighten so that the cutting unit's rear edge is 2-4 mm higher than its front.
4. Check the measurement.
5. Then tighten the two nuts on the stay.

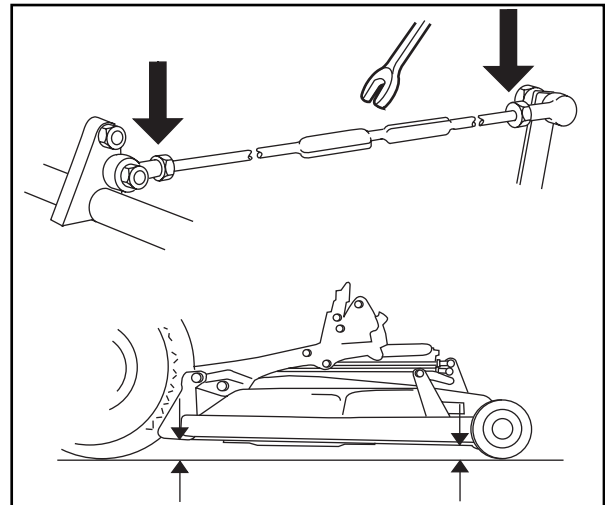

8009-027  
8009-026

### Cutting Height

1. Loosen the nut on the height adjustment stay.
2. Adjust so that the distance between the stop for lowest height setting and the protective frame is 5 mm.
3. Tighten the nut.
4. Recheck that the parallelism has not changed. If so, the parallelism must be readjusted.
5. Check and adjust if necessary the cutting unit's ground pressure as described in the next section.
6. Attach the nose cover.

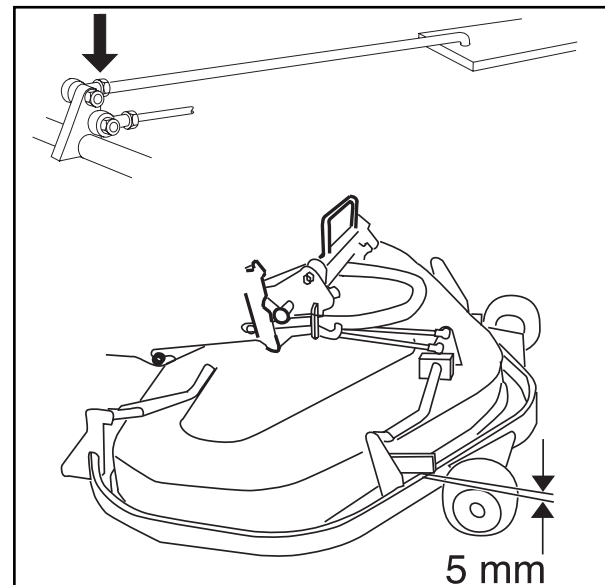

8009-028  
8009-029

#### IMPORTANT INFORMATION

**When changing the cutting unit, you must readjust the parallelism and cutting height.**

# MAINTENANCE

## Checking and Adjusting the Ground Pressure

In order to achieve the best mowing result the cutting unit should follow the ground without touching it too heavily. Pressure is adjusted using a screw and spring on each side of the Rider.

Adjust the cutting unit's ground pressure in the following manner:

1. Place a set of bathroom scales under the cutting unit's frame (on the front edge) so that the unit rests on the scales. If necessary a block can be placed between the frame and the scales so that the anti-scalp rollers do not support any weight.
2. Adjust the cutting unit's ground pressure by screwing the adjuster screws, which are located behind the front wheels on both sides, in or out.

The ground pressure should be between 12 and 15 kg and the springs evenly tensioned.

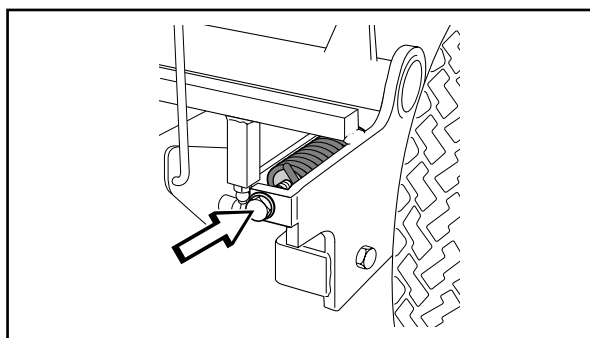
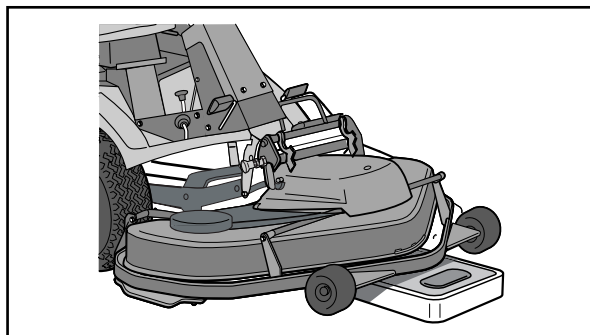

## The Cutting Unit's Service Position

In order to provide good accessibility for cleaning, repair and servicing, the unit can be set in the service position. The service position means that the unit is raised and locked in the vertical position.

### Placing in the Service Position

1. Place the unit so that it hangs on the outer hooks by carrying out steps 1-11 under Removing the Cutting Unit on page 43.
2. Take hold of the unit's front edge and lift it to a vertical position. The unit locks automatically in the vertical position.

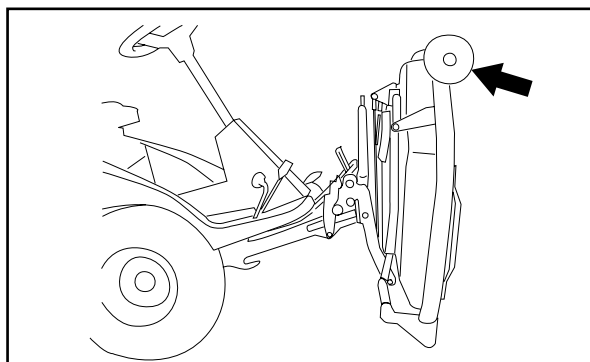

### Releasing the Service Position

1. Ease up the unit's edge (tilt it back), move the handle forward and slowly lower the unit to the horizontal position.
2. Slide the unit into its operational position by carrying out points 4-8 under Attaching the Cutting Unit on page 38.

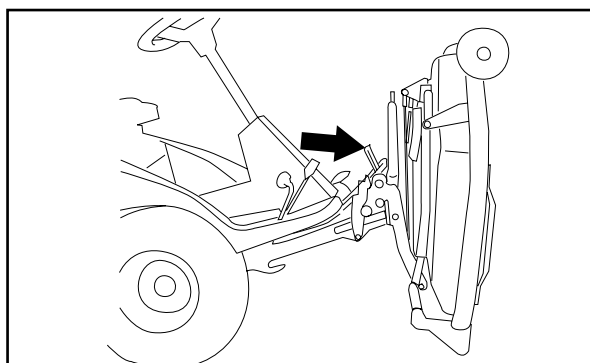

# MAINTENANCE

## Checking the Blades

It is important that the blades are undamaged and well-ground to give the best mowing result.

Check that the blades are screwed tightly with sufficient torque (45 Nm).

### IMPORTANT INFORMATION

**Replacement or sharpening of the blades should be carried out by an authorised service representative.**

The blades should be balanced after sharpening.

Damaged blades should be replaced when hitting obstacles that result in a breakdown. Let the servicing dealer judge whether the blade can be repaired/ground or must be discarded.

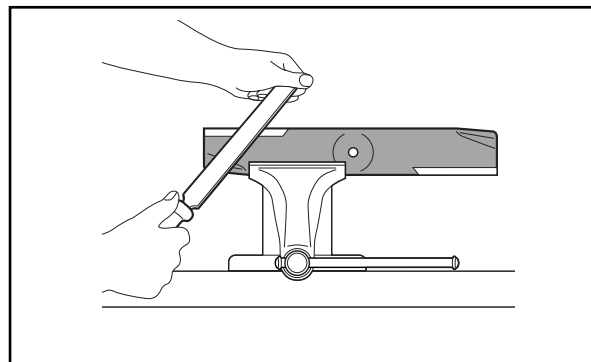

6012-088



### WARNING!

**If the blades are cracked, whether caused by poor repair or other damage, they could break while being used. The risk increases if the blades are poorly balanced.**

## Cutting Unit Model

This machine type comes with a Combi 122 as standard equipment.

Other cutting units cannot be mounted without changing the drive belt.

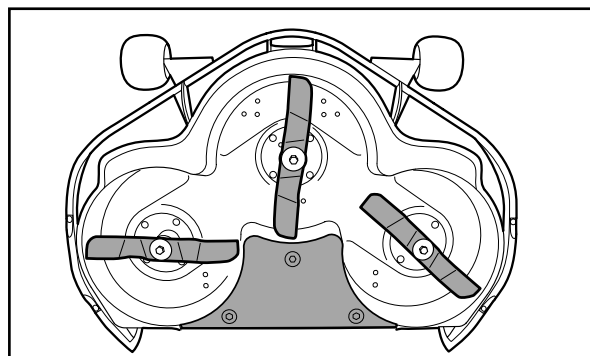

8009-290

*Combi 122*

# MAINTENANCE

## Removing the Cutting Unit



**WARNING!**  
Exercise caution.  
Risk of crush injuries

1. Place the machine on a flat surface.
2. Lock the brakes by pressing down the pedal and locking with the push-button.

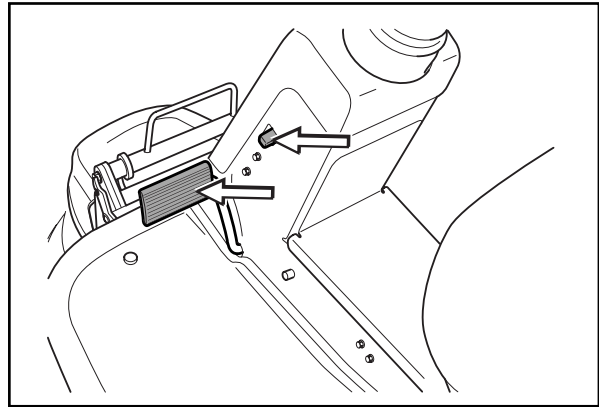

8009-328

3. Lift the cutting unit with the mechanical lifting lever.
4. Remove the nose cover.

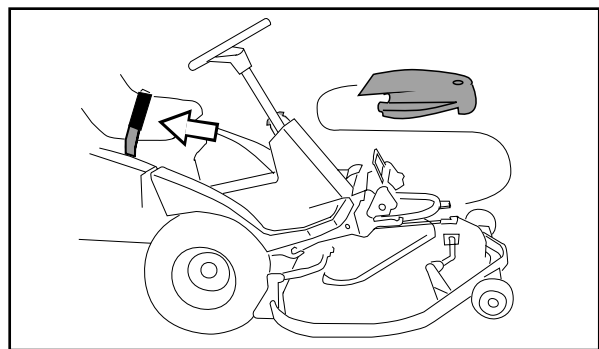

8009-375

5. Loosen the belt tension spring.
6. Remove the belt from the front pulley.
7. Re-attach the belt tension spring.

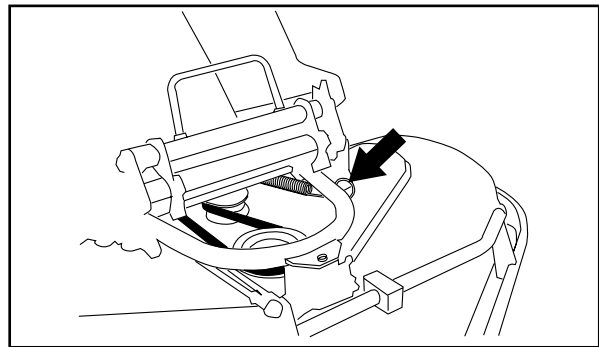

8009-008

8. Hang the belt around the handle.

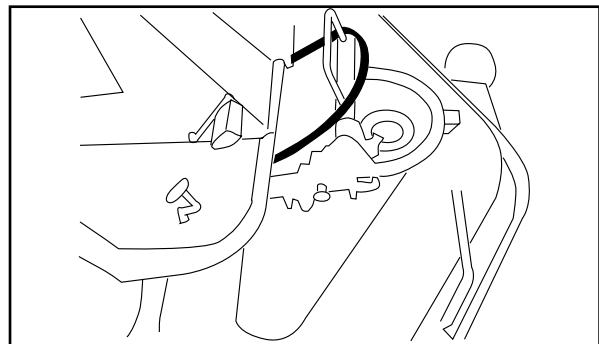

8009-009

# MAINTENANCE

9. Unhook the height adjustment handle (E) by moving the rear part forward:

Loosen the stay if necessary by pulling the frame's forward section up or down.

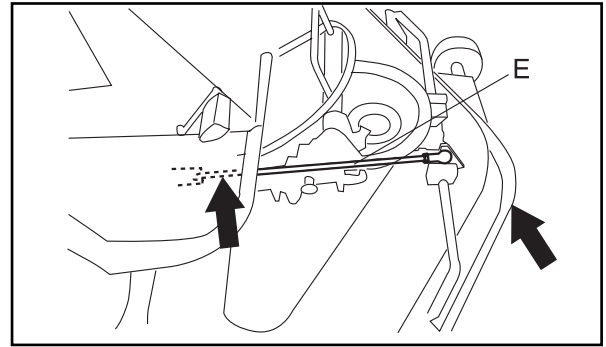

8009-169

10. Pull the handle (D) and unit simultaneously. Release the handle when the unit has come out a bit.

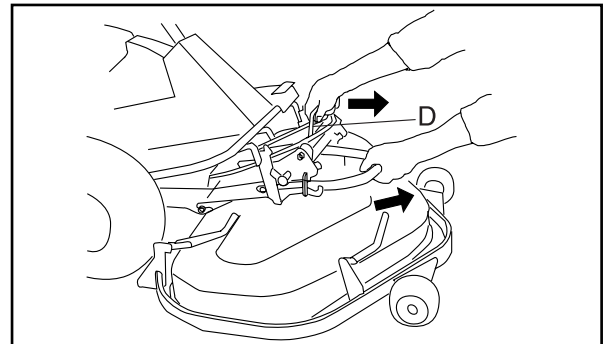

8009-170

11. Pull out the unit so that it catches on the outer hooks.
12. Lower the unit with the lifting lever on the driver's right side.

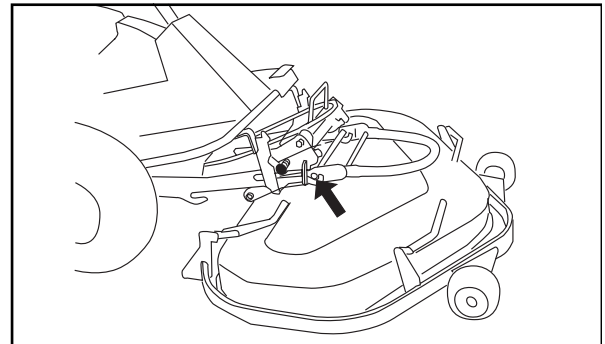

8009-024

13. Pull the handle (D) so that the safety catch locks. Check that the catch (A) is in the inset position.

14. Remove the unit from the machine.

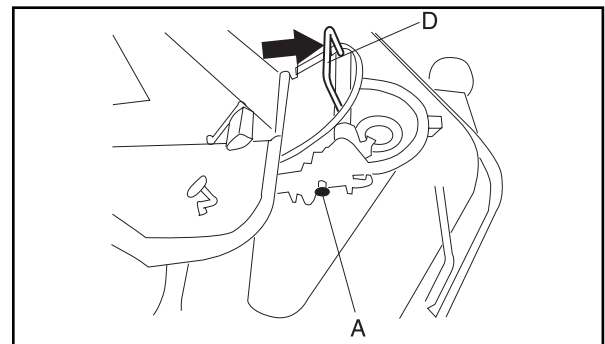

8009-171

# MAINTENANCE

## Removing the Cutting Unit Frame

Starting position for removing the unit frame:

- Cutting unit removed.
1. Twist the catch out so that the forward fastener can be lifted from the cutting unit.
  2. Move the unit frame backwards so that the tongue of the cutting unit releases its grip on the bar of the unit frame and lift the frame off.

Attach the parts in the reverse order.

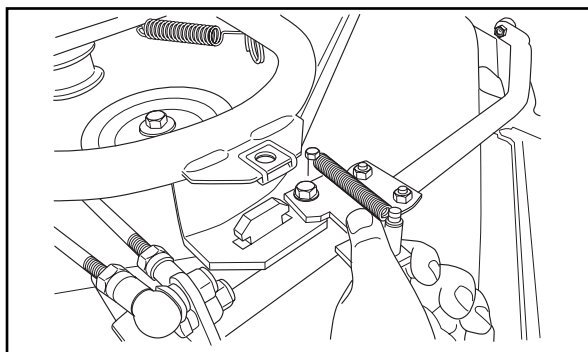

8009-184

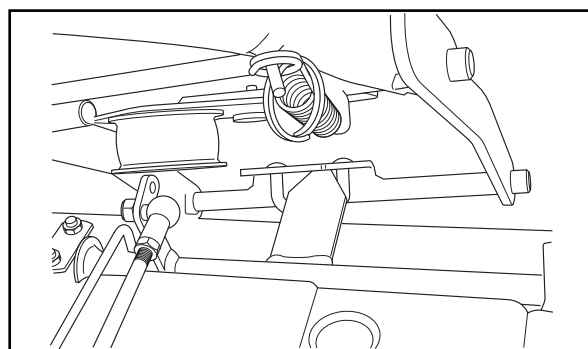

8009-185

## Removing the Belt

Starting position for removing the belt:

- No unit is attached to the machine.
- The belt's forward part is hung around the handle of the safety catch.

Detaching the forward part of the belt from the forward pulley is described in points 5-8 under Removing the Cutting Unit on page 43.

The entire belt is removed according to the following only when a snow blade is to be attached to the machine.

1. Press the guide plate under the anti-scalp roller.
2. Unhook the spring to the blade brake.
3. Remove the belt from the middle pulley and remove the belt.

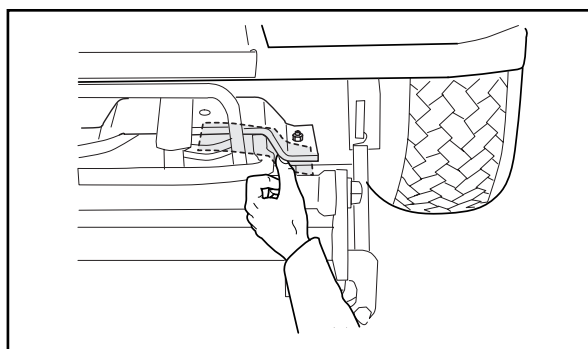

8009-343

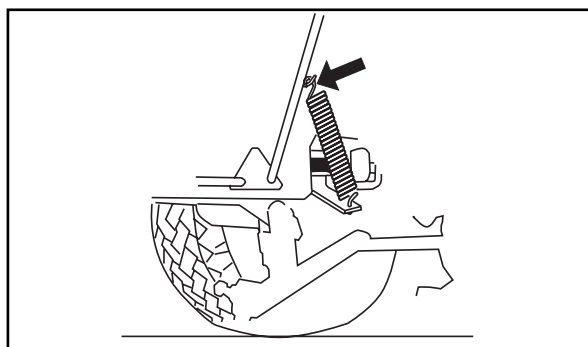

8009-005

# MAINTENANCE

## Attaching the Belt

1. Place the forward part of the belt in place and hang the forward part around the handle of the safety catch.
2. Put the belt on the middle pulley and against the anti-scalp rollers.

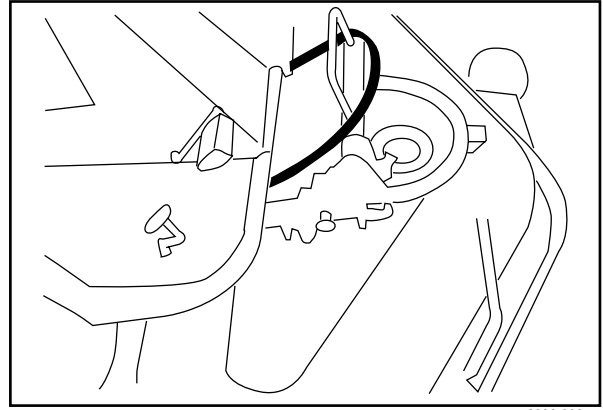

8009-009

3. Press the guide plate down under the anti-scalp rollers and push the belt into place.

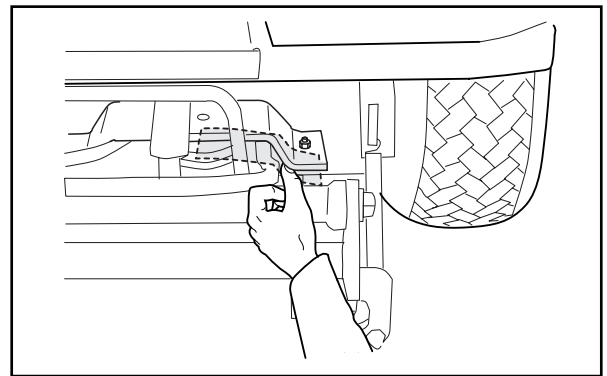

8009-343

4. Hook the spring to the blade brake.

Attaching the belt to the forward pulley is described in points 6-7 under Attaching the Cutting Unit, see page 37.

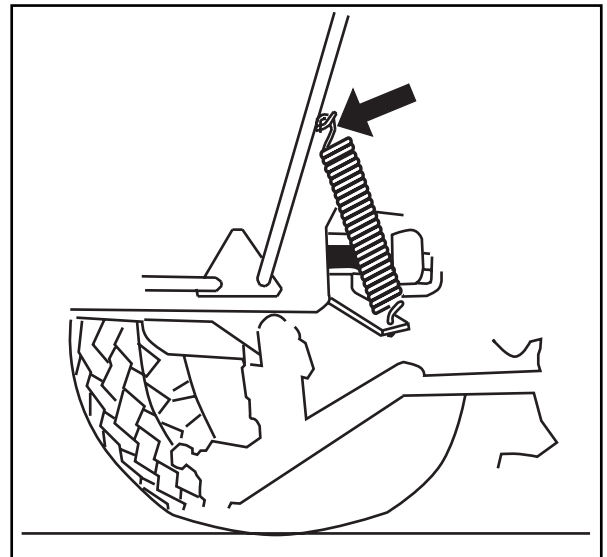

8009-005

# MAINTENANCE

## Changing the Cutting Unit's Belt



### WARNING!

Protect your hands with gloves when working with the blades.  
There is a risk of crush injuries when working with the belt.

### Belt changes on the Combi unit.

On these cutting units with "collision-proof" blades, the blades are driven by one V-belt. Do as follows to change the V-belt:

1. Remove the cutting unit, see page 43.
2. Loosen the unit frame (1) see page 45, the bolt to the parallelism handle (2), and the two screws on the cover (3). Lift the protective cover from the belts.

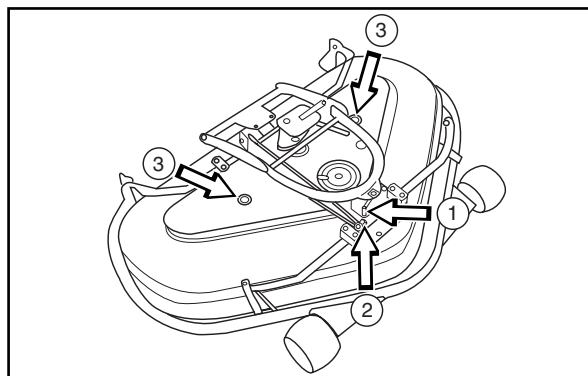

6016-113

3. Loosen the spring (4) that tensions the V-belt and wriggle the belt off.
4. Attach the new belt.  
The belt tightening schedule is located on a decal on the inside of the protective cover.
5. Check that the belt tensioning equipment is not jammed or binding and replace the spring.
6. Replace the protective cover and attach the parallelism handle and unit frame.

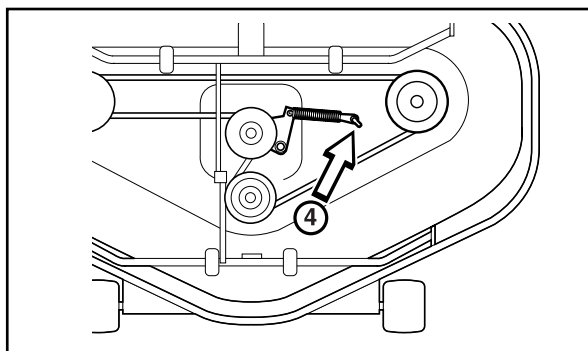

6012-376

7. Attach the cutting unit to the machine, see Attaching the Cutting Unit on page 38.

### Removing the BioClip Plug (Combi)

To change a Combi unit from the BioClip function to a cutting unit with rear ejection, remove the BioClip plug, which is located under the unit, attached with three screws.

1. Put the unit in service position, see The Cutting Unit's Service Position on page 41.
2. Remove the three screws holding the BioClip plug, and remove the plug.
3. Tip: Fit three full-thread screws M8x15 mm in the screw holes to protect the threads.
4. Return the unit to the normal position.

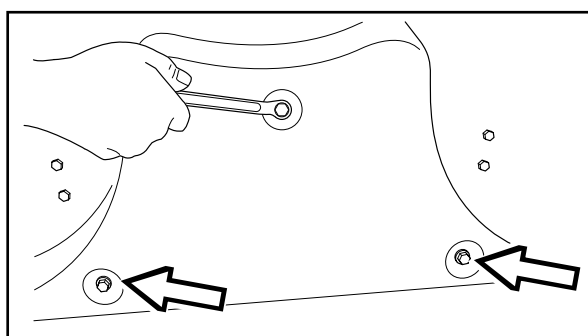

8009-289

Removal of BioClip Plug

Fit the BioClip plug in the reverse order.



# LUBRICATION

## Lubrication

### Lubrication Schedule

When in daily use, the weekly lubrication (1/52) schedule should be carried out twice a week.

500h (365/365)	100h (365/365)	1/52	1/365 (25h)	Rider ProFlex 21 II	1/365	1/52	200h (365/365)	500h (365/365)	
					7				
					1				
					2				
						8			
						9			
					3	10			
						11			
					4	12			
					5	13			
					6	14			

8009-344

---

# LUBRICATION

---

## General

Remove the ignition key to prevent unintentional movements during lubrication.

When lubricating with an oilcan, it ought to be filled with engine oil.

When lubricating with grease, unless otherwise stated, grease 503 98 96-01 or another chassis or ball bearing grease offering good corrosion protection shall be used.

With daily use, the Rider should be lubricated twice weekly.

Wipe away excess grease after lubrication.

It is important to avoid getting lubricant on the belts or the drive surfaces on the belt pulleys. Should this happen, attempt to clean them with spirits. If the belt continues to slip after cleaning with spirits, it must be replaced. Petrol or other petroleum products must not be used to clean belts.

## Lubricating the Cables

Grease both ends of the cables and move the controls to end stop positions when lubricating. Re-attach the rubber covers on the cables after lubrication. Cables with sheaths will bind if they are not lubricated regularly. If a cable binds, the unit may become difficult to operate - it may be hard to get the differential lock out, for example.

If a cable binds, remove the cable and hang it vertically. Lubricate it with thin engine oil until the oil begins to escape from the bottom. Tip: Fill a small plastic bag with oil and tape it so that it seals against the casing and allow the cable to hang vertically from the bag overnight. If you do not succeed in lubricating the cable, it must be replaced.

## Lubricating in Accordance with the Lubrication Schedule

The numbers in the following headings refer to the lubrication points as described in Lubrication Schedule on page 47.

### 1. Pedal Mechanism in Frame Tunnel

Lubricate the pedal mechanism in the frame tunnel.

Remove the cover of the frame tunnel by loosening the screws (two on the steering servo housing).

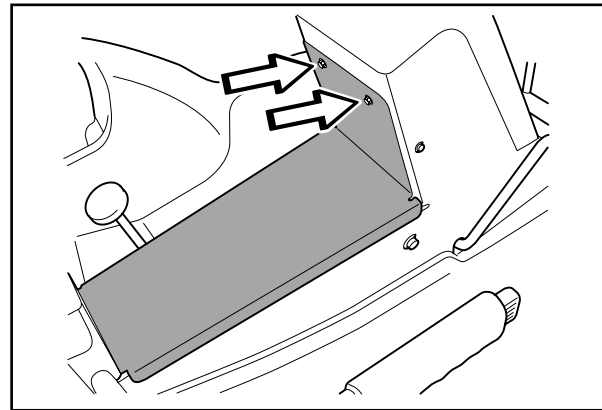

Work the pedals and lubricate the moving parts with an oilcan.

Lubricate the cables to the brake and drive pedals with an oilcan.

Lubricate the point Chains in the Frame Tunnel before replacing the cover to the frame tunnel.

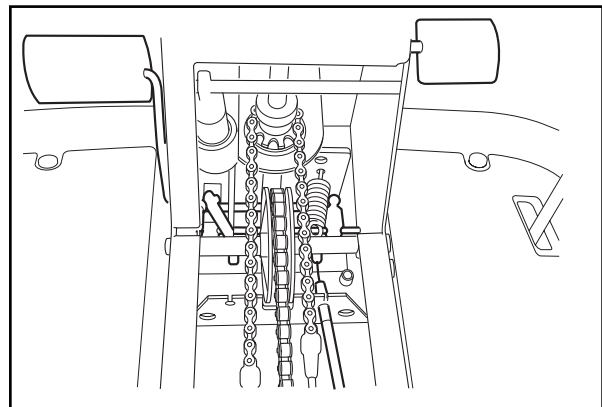

# LUBRICATION

## 2. Chains in the Frame Tunnel

Remove the cover from the frame tunnel, see point 1.

Lubricate the chains in the frame tunnel with an oilcan or chain lubricant spray for motorcycles.

Lubricate the steering cable pulley axle with grease. Move the pulleys to one side and brush grease on the axle.

Replace the cover on the frame tunnel.

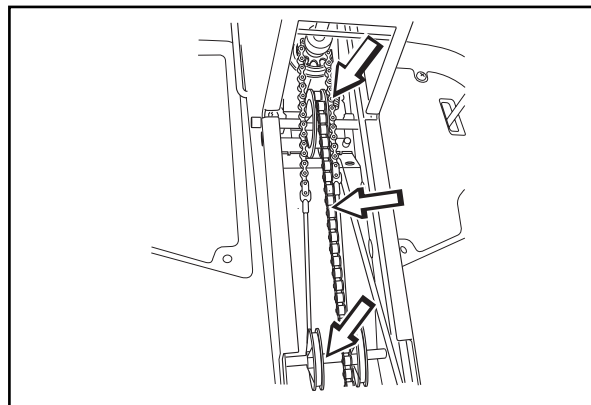

8009-346

## 3. Differential Lock Cable

Remove the cable's rubber casing and lubricate the cable with an oilcan. Depress the pedal a few times, lubricate again, and replace the rubber casing.

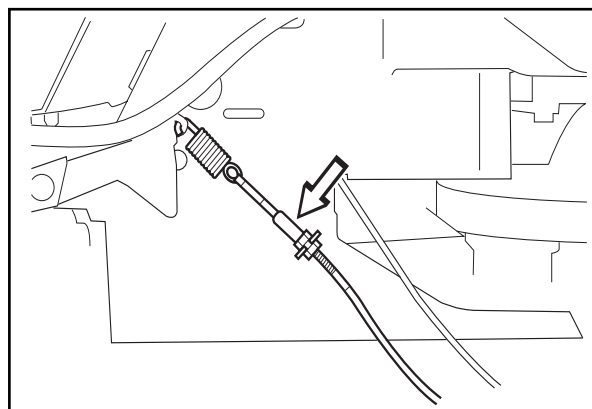

6020-023

## 4. Engine Oil

The engine oil should be changed the first time after 8 hours running time. It should then be changed after every 100 hours of running.



### WARNING!

Engine oil can be very hot if it is drained directly after stopping the engine. Allow the engine to cool somewhat first.

### IMPORTANT INFORMATION

Used engine oil is a health hazard and must not be disposed of on the ground or in nature; it should always be disposed of at a workshop or appropriate disposal location.

1. Open the engine cover.
2. Place a container underneath the engine's left oil drainage screw.
3. Remove the dipstick. Remove the drainage screw from the engine's left side.
4. Let the oil run out into the container.
5. Then replace the oil screw and tighten it.
6. Replace the oil filter if necessary.
7. Fill with new engine oil according to the instructions on the next page.

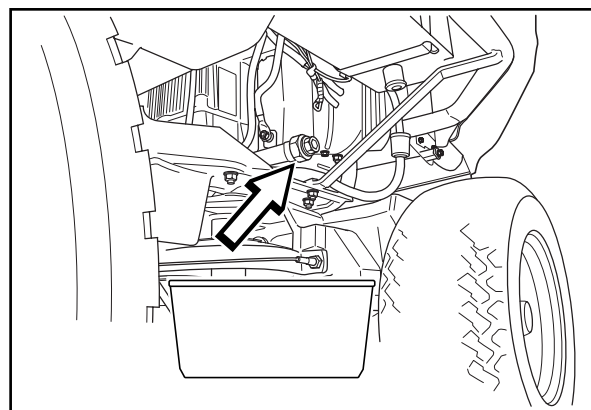

8009-160

# LUBRICATION

Check the oil level in the engine when the Rider stands horizontal.

Fold up the engine cover.

Remove the dipstick, wipe it clean, and then replace it.

The dipstick shall **not** be screwed into place.

Take the dipstick out again and read the oil level.

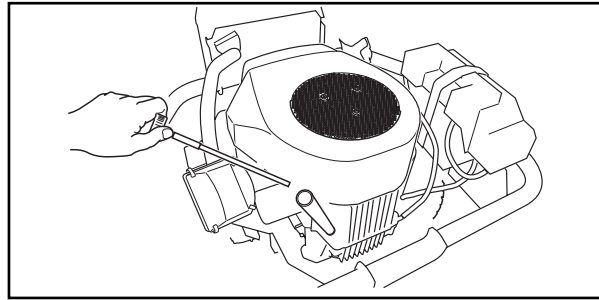

8009-158

The oil level should be between the markings on the dipstick. If the level is close to the ADD mark, fill with oil up to the FULL mark on the dipstick.

Never fill above the FULL mark.

The oil is topped up through the hole the dipstick sits in.

Use engine oil SAE 30 or SAE 10W/30 or, alternately, 10W/40, class SC-SH (over 0 °C/+32 °F).

Over +20 °C/+68 °F SAE 40 can be used.

Use engine oil SAE 5W/20, class SC-SH (under 0 °C/+32 °F).

The engine holds 1.5 litres of oil excluding the filter (including filter 1.7 litres).

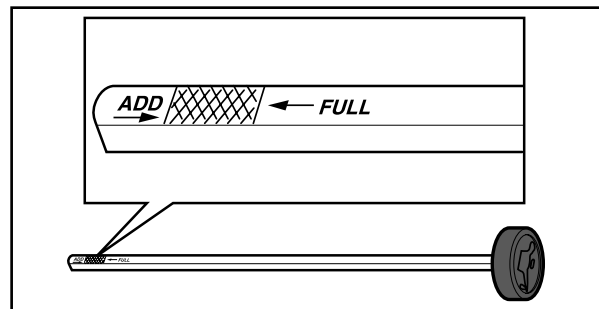

8009-159

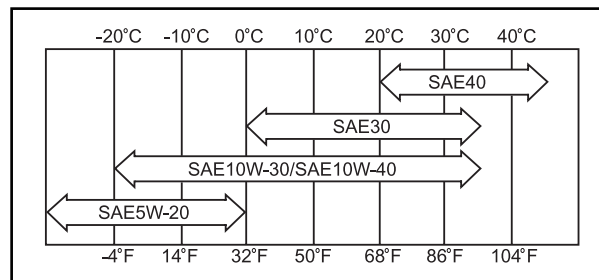

8009-140

## 5. Gear Controller

Remove the transmission cover, two screws.

Lubricate the joints and bearings on the left side with an oilcan.

Remove the rubber casing and lubricate the hydrostatic transmission cable with an oilcan. Press the pedal a few times and lubricate again.

Replace the rubber cover.

Replace the transmission cover.

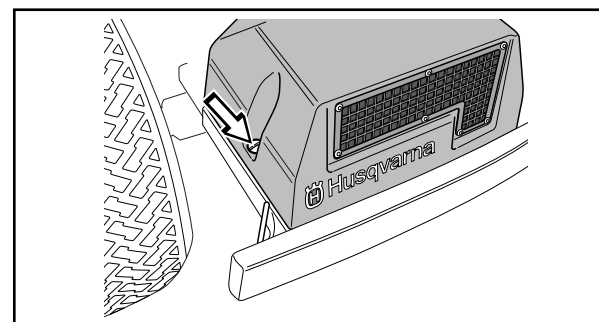

6008-209

## 6. Transmission

The oil and filter should be changed by an authorised service representative, as described in the Workshop Manual.

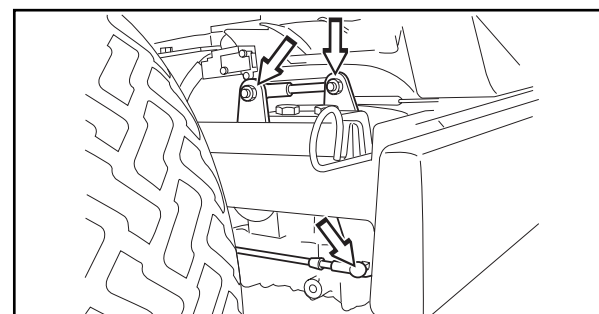

6020-024

# LUBRICATION

## 7. Cutting Unit

Remove the nose cover.

Lubricate using an oilcan:

A. The catch

- Joints and bearings

Lubricate using grease:

B. Interior plug

C. Groove for equipment frame

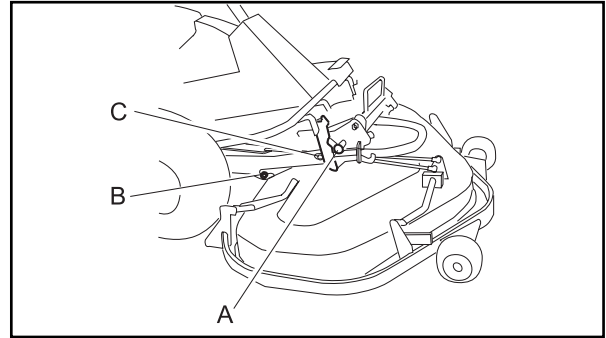

6020-004

## 8. Three-point Link

Lube nipple located behind right front wheel.

Lubricate with grease gun until grease appears.

Use molybdenum disulphide grease.

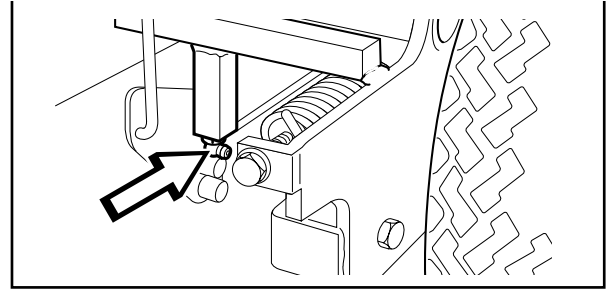

6008-233

## 9. Driver's Seat

Tilt the seat back.

Lubricate the lengthways adjustment mechanism with the oilcan.

Lubricate the lengthways adjustment runners with grease. Pull the seat back and forth and lubricate on both sides.

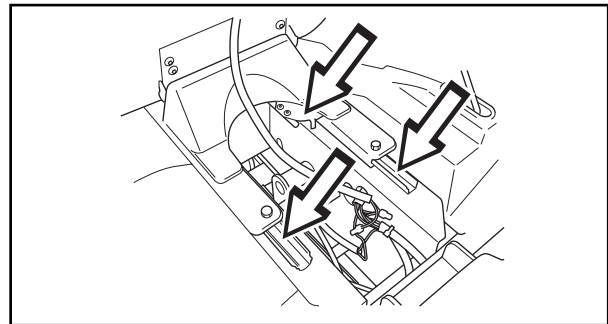

8009-347

## 10. Throttle and Choke Cables, Lever Bearings

Remove the right side cover of the lever housing (2 screws) and open the engine cover. Lubricate the cables free ends with the oilcan, even those by the carburettor. Move the controls to the end points and lubricate again.

Lubricate the joints, catches, and bearings for the cutting unit's control levers with an oilcan.

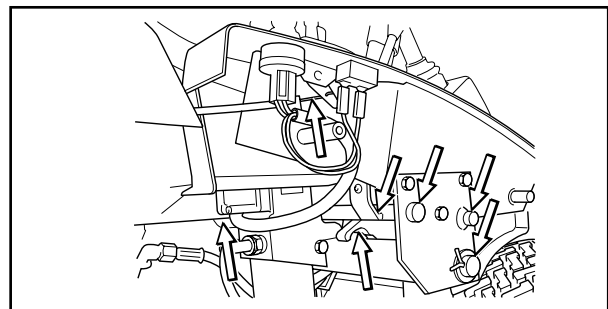

8009-349

Replace the lever housing's side cover.

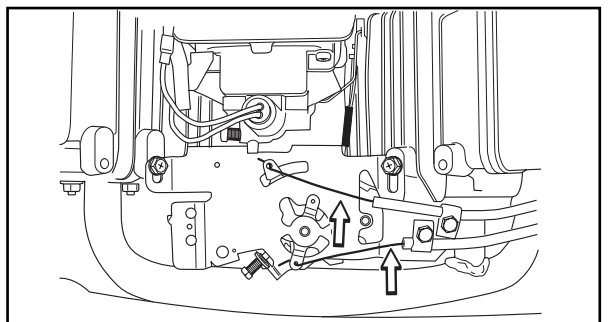

8009-178

# LUBRICATION

## 11. Hydraulic Oil Filter, Change

1. Remove the oil filter. If necessary, use a filter remover.
2. Wipe new, clean engine oil onto the seal for the new filter.
3. Mount the filter by hand with + 3/4 turn.
4. Remove the transmission cover and fill the transmission's oil tank, about 0.3 l oil. See 14. Transmission Oil Level on page 53. Be observant when running the engine as described below and fill so that the tank is not emptied.
5. Run the engine warm, manipulate the hydraulic lifts and servo steering, and then check that there are no leaks around the oil filter seal.
6. Check the oil level in the transmission, top up if necessary. The oil filter holds 0.3 litres of oil.

Replace the transmission cover.

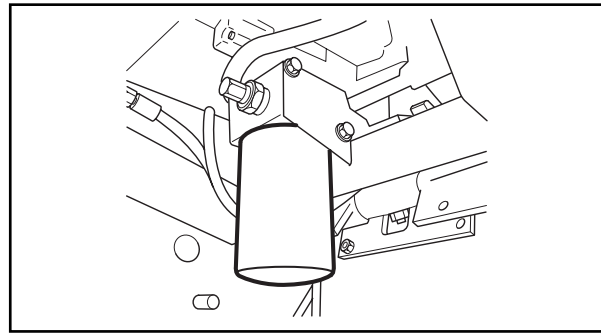

8009-350

### IMPORTANT INFORMATION

Used oil filters shall be treated as harmful to the environment and turned in to the workshop or other designated area for disposal.

## 12. Oil Filter, Change

1. Open the engine cover.
2. Drain the engine oil as described in 4. Engine Oil on page 49.
3. Remove the oil filter. If necessary, use a filter remover.
4. Wipe new, clean engine oil onto the seal for the new filter.
5. Mount the filter by hand with + 3/4 turn.
6. Run the engine warm, then check that there are no leaks around the oil filter seal.
7. Check the oil level in the engine, top up if necessary. The oil filter holds 0.2 litres of oil.

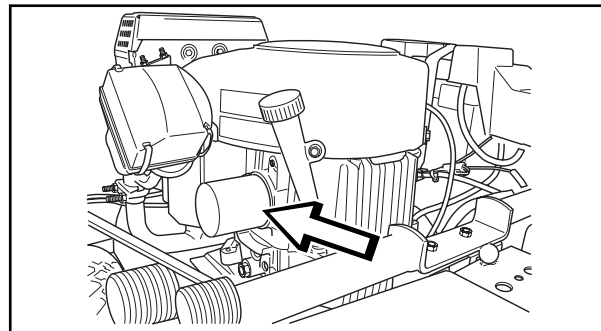

8009-161

## 13. Parking Brake Cable

Remove the transmission cover, see Gear Controller.

Unhook the spring (A) from the screw (B) if required.

Remove the cable's rubber casing when lubricating.

Lubricate the cable with an oilcan, press the brake pedal a few times and lubricate again.

Replace the spring (A) and the transmission cover.

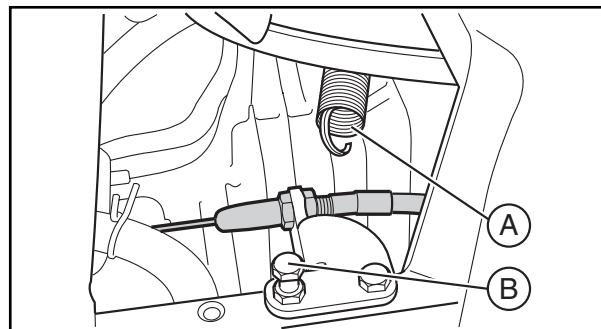

6020-005

# LUBRICATION

## 14. Transmission Oil Level

1. Check the oil level in the transmission by looking through the air intake mesh. The oil level shall be between the MIN and MAX markings on the oil container when at +20°C.

If the oil needs to be filled, you must first remove the transmission cover.

2. Unscrew the oil container's cover and fill with SAE 10W/30 engine oil, class SF-CC, until the oil level reaches the MAX mark. Then screw the oil container's cap into place and attach the transmission cover.

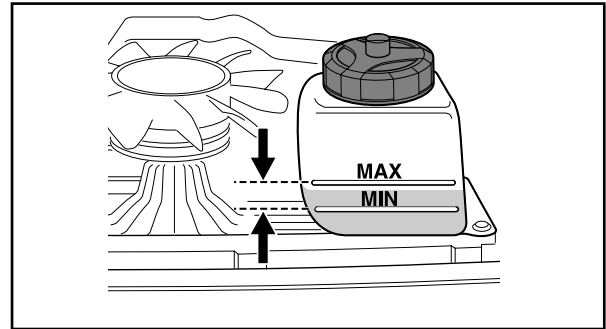

6008-210

---

# LUBRICATION

---

## **Accessories**

Lubrication or other maintenance of optional equipment or accessories, see Accessories on page 15, is not described in this manual. This equipment too, naturally, requires maintenance. See the manuals for the respective accessories for instructions.

It's good practice to make a note of maintenance or necessary actions performed on this page.



# TROUBLE SHOOTING

## Trouble Shooting Guide

Problem	Cause
The engine will not start.	<ul style="list-style-type: none"> <li>• Fuel tank empty</li> <li>• Incorrect fuel type</li> <li>• Faulty spark plugs</li> <li>• Faulty spark plug connections</li> <li>• Dirt in the carburettor or fuel line</li> </ul>
Starter does not turn the engine	<ul style="list-style-type: none"> <li>• Cutting unit in incorrect position</li> <li>• Brake not applied</li> <li>• Hydrostat pedals not in the neutral position</li> <li>• Discharged battery</li> <li>• Poor contact affecting the battery terminal cable connections, ignition lock, or starter</li> <li>• Main fuse blown The fuse is found in front of the battery, under the battery cover</li> <li>• Faulty ignition lock</li> <li>• Faulty starter</li> </ul>
The engine runs erratically	<ul style="list-style-type: none"> <li>• Faulty spark plug</li> <li>• Incorrect carburettor setting</li> <li>• Clogged air filter</li> <li>• Blocked fuel tank ventilation</li> <li>• Incorrect ignition setting</li> <li>• Dirt in the fuel line</li> <li>• Choking or incorrectly adjusted choke cable</li> <li>• Incorrect fuel type</li> </ul>
Abnormal exhaust smoke	<p>Black smoke:</p> <ul style="list-style-type: none"> <li>• Choking or incorrectly adjusted choke cable</li> <li>• Incorrect carburettor setting</li> <li>• Clogged air filter</li> </ul> <p>Blue smoke:</p> <ul style="list-style-type: none"> <li>• Oil mixed with fuel in tank</li> <li>• Serious engine damage</li> </ul> <p>Thick pale smoke:</p> <ul style="list-style-type: none"> <li>• Tank filled with diesel</li> </ul>
The engine lacks power	<ul style="list-style-type: none"> <li>• Clogged air filter</li> <li>• Faulty spark plugs</li> <li>• Dirt in the carburettor or fuel line</li> <li>• Incorrect carburettor setting</li> <li>• Choking or incorrectly adjusted choke cable</li> <li>• Incorrect fuel type</li> </ul>

# TROUBLE SHOOTING

<b>Problem</b>	<b>Cause</b>
Engine overheating	<ul style="list-style-type: none"><li>• Engine overloaded</li><li>• Air intake or cooling fins clogged</li><li>• Damaged fan</li><li>• Too little or no oil in the engine</li><li>• Faulty pre-ignition</li><li>• Faulty spark plugs</li></ul>
Battery does not charge	<ul style="list-style-type: none"><li>• One or more battery cells faulty</li><li>• Poor contact on the battery terminal cable connectors</li><li>• Faulty generator or regulator</li><li>• Insufficient battery maintenance</li></ul>
The Rider vibrates	<ul style="list-style-type: none"><li>• The blades are loose</li><li>• The engine is loose</li><li>• Pulley loose or bearings worn</li><li>• One or more blades imbalanced, caused by damage or poor balancing after sharpening</li></ul>
Uneven cutting result	<ul style="list-style-type: none"><li>• Blades blunt</li><li>• Cutting unit set incorrectly</li><li>• Long or wet grass</li><li>• Grass build-up under the cover</li><li>• Different air pressure in the right and left tyres</li><li>• Driving speed too high</li><li>• Engine speed too low</li><li>• Drive belt slips</li></ul>

---

# STORAGE

---

## Storage

### Winter Storage

At the end of the mowing season, the Rider should be readied for storage, likewise if it will not be in use for more than 30 days. Fuel allowed to stand for long periods of time (30 days or more) can leave sticky residues that can clog the carburettor and disrupt engine function.

Fuel stabilizers are an acceptable option as regards sticky residues during storage. If alkylate petrol is used, stabilisers are unnecessary because this fuel is stable. However, you should avoid switching between standard and alkylate petrol as sensitive rubber components can harden. Add stabiliser to the fuel in the tank or in the storage container. Always use the mixing ratios specified by the manufacturer of the stabiliser. Run the engine for at least 10 minutes after adding the stabiliser so that it reaches the carburettor. Do not empty the fuel tank and the carburettor if you have added stabiliser.

**WARNING!**

**Never store an engine with fuel in the tank indoors or in poorly ventilated spaces where fuel vapour can come in contact with open flames, sparks, or a pilot light such as in a boiler, hot water tank, clothes drier, etc. Handle the fuel with care. It is very flammable and careless use can cause serious personal injury and property damage. Drain the fuel into an approved container outdoors and far away from open flames. Never use petrol for cleaning. Use a degreasing agent and warm water instead.**

To ready the Rider for storage, follow these steps:

1. Clean the Rider thoroughly, especially under the cutting unit. Touch up damage to the paint to prevent rust.
2. Inspect the Rider for worn or damaged parts and tighten any nuts or bolts that may have become loose.
3. Change the engine oil; dispose of properly.
4. Empty the fuel tank. Start the engine and let it run so that even the petrol in the carburettor is emptied.
5. Remove the spark plugs and pour about a tablespoon of engine oil into each cylinder. Turn over the engine so that the oil is evenly distributed and then refit the spark plugs.
6. Lubricate all grease nipples, joints, and shafts.
7. Remove the battery. Clean, charge, and store in a cool place.
8. Store the Rider in a clean, dry place and cover it for extra protection.

---

# STORAGE

---

## Service

Low season is the most suitable time to perform a service or overhaul of the machine in order to ensure high function safety during high season.

When ordering spare parts, please specify the purchase year, model, type, and serial number of the Rider.

Always use genuine Husqvarna spare parts.

An annual check-up or trimming at an authorised service representative is a good way to ensure that your Rider performs at its best the following season.

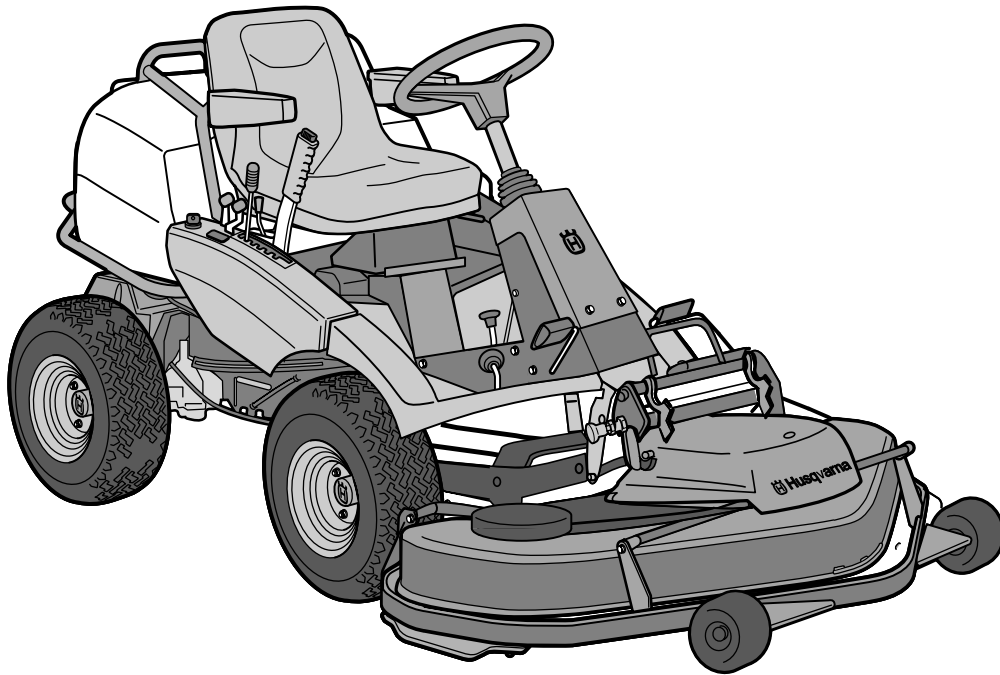

8009-318

# ELECTRICAL SYSTEM

## Electrical and Hydraulic Systems

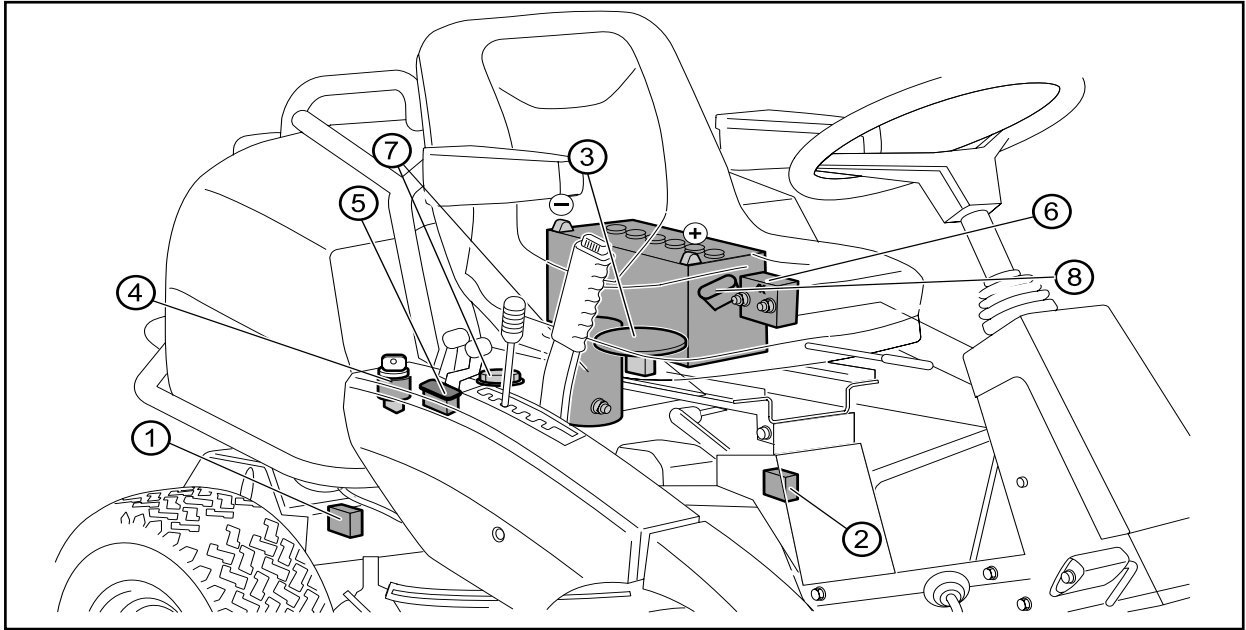

Electrical System: Component Locations

8009-356

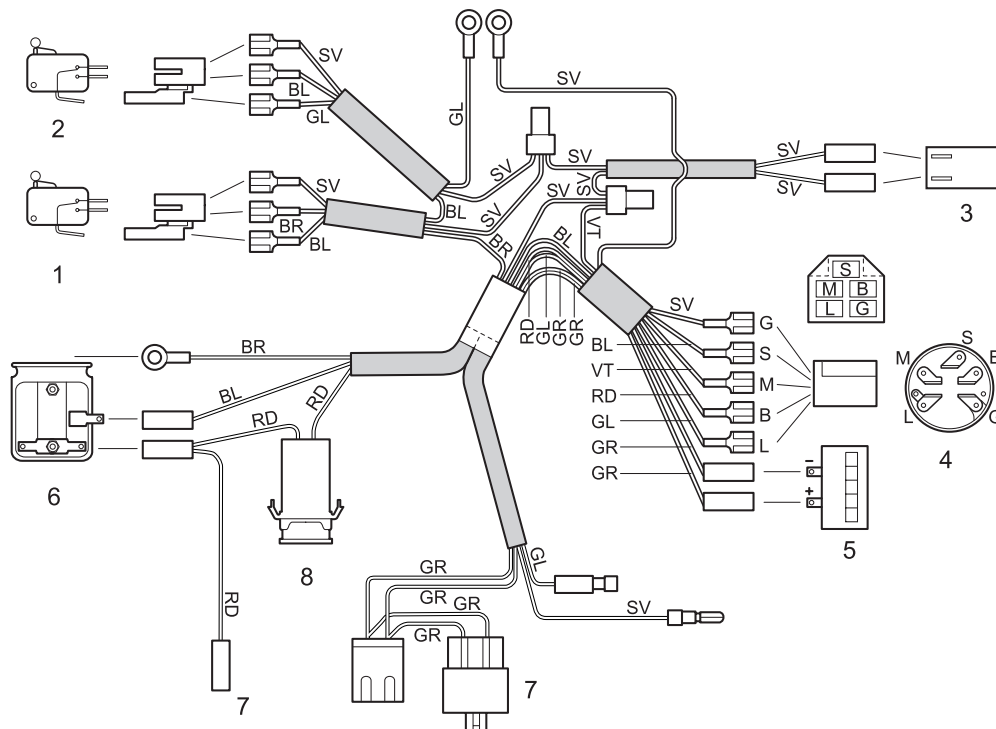

8009-186

1. Microswitch, hydrostatic transmission
2. Microswitch, cutting unit
3. Microswitch, seat
4. Ignition lock
5. Chronometer
6. Start relay
7. Motor connectors
8. Fuse 15 A

Key for colour abbreviations in wiring diagram

- RD = Red
- BL = Blue
- VT = White
- SV = Black
- GL = Yellow
- GR = Grey
- BR = Brown

# HYDRAULIC SYSTEM

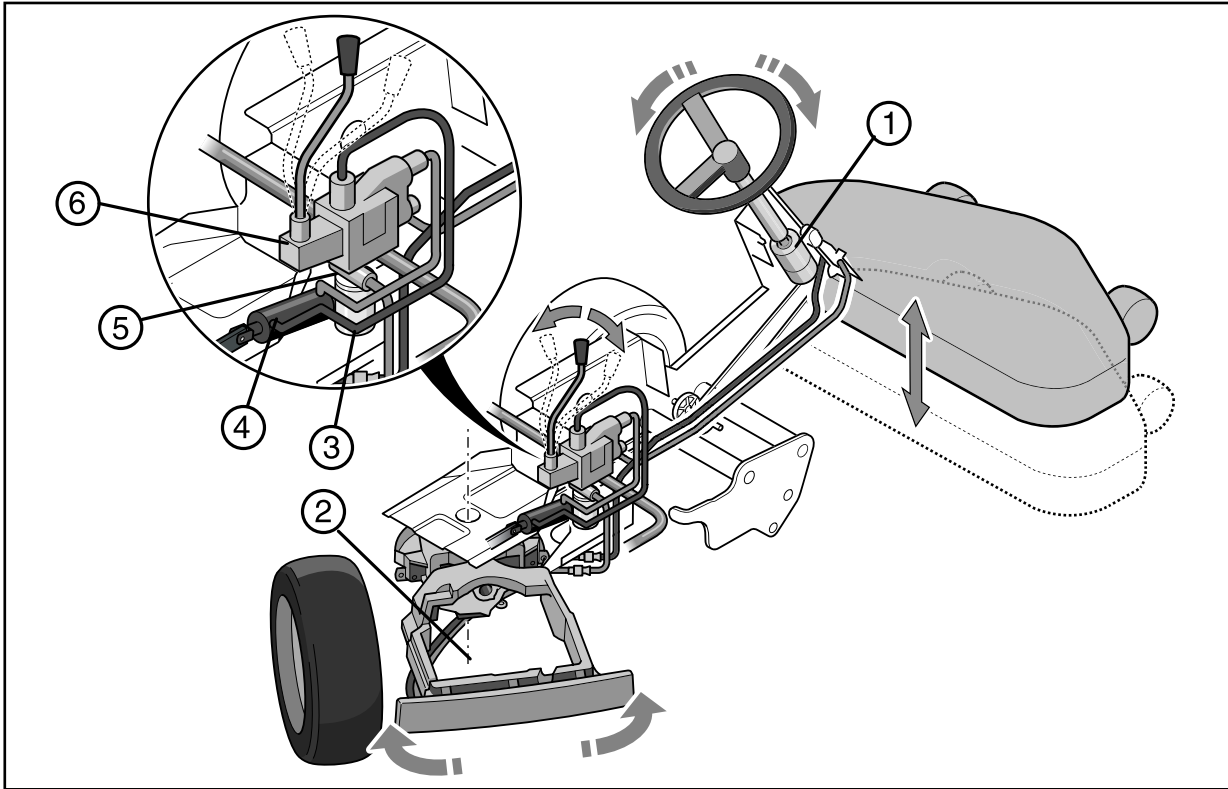

8009-357

## Hydraulic System: Component Locations

1. Steering servo
2. Pump in hydrostatic transmission
3. Hydraulic oil filter
4. Lift cylinder
5. Pressure limiting valve
6. Control valve for lift cylinder

Keep the hydraulic system clean. Remember to:

- Thoroughly clean before the top-up cap is opened or any connector loosened.
- Use clean containers when topping up the oil.
- Only use pure oil that has been stored in a sealed container.
- Not reuse drained oil.
- Change the oil and filter according to the intervals specified in Maintenance Schedule on page 25.

In order for a hydraulic system to function without problem, it must be free from foreign objects. When used, the system produces particles, which can cause both wear and abnormal function. In order to remove these particles, the system contains filters. The filters are sized so as to capture the produced particles, but if contaminants are introduced from outside the system, the filters can quickly become clogged and fail to function as intended. If there are contaminants in the system, further contamination will be produced in a self-propagating cycle. The result will be function disruptions and much work to clean the system.

---

# TECHNICAL DATA

---

## Technical Data

### Rider ProFlex 21 II

#### Dimensions

Length base machine	2,120 mm with towing eye
Length with Combi 122	2,550 mm
Width base machine	1,100 mm
Width with cutting unit	1,330 mm
Height	1,100 mm
Operating weight base machine	309 kg without cutting unit
Wheel base	1,010 mm
Track width	720 mm
Wheel dimensions	18 x 7.50 x 8
Tyre pressure, front and rear	60 kPa (0.6 kp/cm <sup>2</sup> )
Maximum allowable lean	15°

#### Engine

Manufacturer	Kawasaki
Model	FH641V-AS50 or FH641V-BS50
Power	15.5/21 kW/hp
Cylinder volume	675 cm <sup>3</sup> / 41.19 cu.in
Fuel	minimum 87 octane unleaded (maximum methanol 5%, maximum ethanol 10%, maximum MTBE 15%).
Tank volume	17 litres
Oil	SAE 30 or SAE 10W/30, SAE 10W/40 class SC -SH
Oil volume	1.5 litres /1.6 US qt
Oil volume incl. filter	1.7 litres /1.8 US qt
Start	Electric start

#### Noise emissions and cutting width

Measured noise level	101 dB(A)
Guaranteed noise level	102 dB(A)
Cutting width	1,220 mm

#### Electrical system

Type	12 V, negative earth
Battery	12 V, 24 Ah
Main fuse	Flat pin 15 A
Spark plugs	NGK BPR4ES, electrode gap = 0.75 mm/0.030"

#### Transmission

Manufacturer	Tuff Torq K 66
Oil	SAE 10W/30, class SF - CC
Oil volume total	3.2 litres

**When this product is spent and is no longer used it should be returned to the dealer or other authority for recycling.**

---

# TECHNICAL DATA

---

## Cutting Unit

### Combi 122

Cutting width	1,220 mm
Cutting heights	7 positions, 40-100 mm
Blade length	450 mm
Width	1,330 mm
Weight with a-frame	68 kg
Length machine with unit	2,550 mm

**In order to introduce improvements the specification and design are subject to alteration without prior notice.**

**Note that no legal demands whatsoever can be made with the support of the information in this operator's manual.**

**Only use original spare parts with repairs. The use of other parts invalidates the warranty.**



# EU DECLARATION OF CONFORMITY

## EU Declaration of Conformity

### EU Declaration of Conformity (only applies to Europe)

We, **Husqvarna AB**, SE-561 82 Huskvarna, Sweden, tel: +46-36-146500, declare under sole responsibility that the **Husqvarna ProFlex 21 II Raider**, from 2002's serial numbers and onwards (the year is clearly stated in plain text on the rating plate with subsequent serial number), conforms with the requirements of the COUNCIL'S DIRECTIVE:

- of June 22, 1998 "relating to machinery" 98/37/EC, annex IIA.
- of May 3, 1989 "relating to electromagnetic compatibility" 89/336/EEC, and applicable supplements.
- of May 8, 2000 "relating to noise emissions into the surroundings" 2000/14/EC. Information regarding noise emissions and the cutting width, see Technical Data.

The following harmonised standards have been applied: **EN292-2, EN836**.

The registered body **0404, SMP Svensk Maskinprovning AB**, Fyrstorgsgatan 3, SE-754 50 Uppsala, Sweden, has issued the report with number **01/901/010** regarding the assessment of conformity according to annex VI to the COUNCIL'S DIRECTIVE of May 8, 2000 "relating to noise emission into the surroundings" **2000/14/EC**.

Huskvarna, January 3, 2002



Roger Andersson, Development Manager/Garden Products



# SERVICE JOURNAL

## Service journal

Action	
<b>Delivery Service</b>	
1. Fill the battery with battery acid and charge for four hours.	<input type="checkbox"/>
2. Fit the steering wheel, seat and, where applicable, other components.	<input type="checkbox"/>
3. Attach the cutting unit.	<input type="checkbox"/>
4. Adjust the cutting unit: Adjust the lifting springs (the weight of the cutting unit should be 12-15 kg) if a brush is to be used, set to maximum spring power). Adjust the cutting unit so that its rear edge is about 2-4 mm higher than its front edge. Adjust the cutting unit's cutting height setting so that the cutting height limit is 5 mm above the unit frame at the lowest cutting height.	<input type="checkbox"/> <input type="checkbox"/> <input type="checkbox"/>
5. Check that the right amount of oil is in the engine and transmission.	<input type="checkbox"/>
6. Check and adjust the air pressure in the tyres (60 kPa, 0.6 bar).	<input type="checkbox"/>
7. Connect the battery.	<input type="checkbox"/>
8. Fill the fuel tank and start the engine.	<input type="checkbox"/>
9. Check that the machine does not move in neutral.	<input type="checkbox"/>
10. Check:	
Driving forwards.	<input type="checkbox"/>
Reversing.	<input type="checkbox"/>
Engaging the blades.	<input type="checkbox"/>
Safety switch in the seat.	<input type="checkbox"/>
Safety switch for the lifting lever.	<input type="checkbox"/>
Safety switch for the hydrostat pedals.	<input type="checkbox"/>
11. Check the engine speed: 3,000 ±75 rpm.	<input type="checkbox"/>
12. Bleed the hydraulic system of excess air.	<input type="checkbox"/>
13. Inform the customer about:	
The need and advantages of following the service schedule.	Delivery service has been carried out.
The need and advantages of leaving the machine for service every 300 hours.	No remaining remarks.
The effects of service and maintaining a service journal on the machine's resale value.	Certified:
Application areas for BioClip.	
14. Fill in the sales papers, etc.	
<b>After the first 8 hours</b>	<b>Date, mileage reading, stamp, signature</b>
1. Change engine oil.	<input type="checkbox"/>

---

# SERVICE JOURNAL

---

Action	Date, mileage reading, stamp, signature
<b>25-Hour Service</b>	
<ol style="list-style-type: none"><li>1. Clean the air cleaner's pre-filter (Oil-foam element). (shorter intervals for dusty operating conditions)</li><li>2. Clean the engine's cooling air intake and the transmission's air intake.</li><li>3. Clean the fuel pump's air filter. (for dusty operating conditions)</li></ol>	Notes

This field is intended for keeping a journal

---

# SERVICE JOURNAL

---

Action	Date, mileage reading, stamp, signature
<b>50-Hour Service</b>	
<ol style="list-style-type: none"><li>1. Clean/change the air cleaner's pre-filter (Oil-foam element). (shorter intervals for dusty operating conditions)</li><li>2. Clean the engine's cooling air intake and the transmission's air intake.</li><li>3. Clean the fuel pump's air filter.</li><li>4. Clean the fuel pump's air filter.</li><li>5. Check/adjust the cutting height.</li><li>6. Check/adjust the parking brake.</li><li>7. Inspect the flame proofing/spark extinguisher (extra equipment).</li></ol>	Notes

This field is intended for keeping a journal

---

# SERVICE JOURNAL

---

Action	Date, mileage reading, stamp, signature
<b>100/200-Hour Service</b>	
<ol style="list-style-type: none"><li>1. Change engine oil. Replace the oil filter every 200 hours.</li><li>2. Clean/change the air cleaner's pre-filter (Oil-foam element).</li><li>3. Clean the air cleaner's paper filter. Replace every 200 hours. (shorter intervals for dusty operating conditions)</li><li>4. Clean the engine's cooling air intake and the transmission's air intake.</li><li>5. Clean the cooling fins on the cylinder and cylinder head.</li><li>6. Check/adjust the cutting height.</li><li>7. Check/adjust the parking brake.</li><li>8. Inspect the flame proofing/spark extinguisher (extra equipment).</li><li>9. Clean/replace the spark plugs.</li><li>10. Change the inline fuel filter.</li><li>11. Replace the hydraulic oil filter every 200 hours.</li><li>12. Clean the fuel pump's air filter.</li><li>13. Clean the pulse air filter.</li><li>14. Check nuts and bolts for tightness.</li><li>15. Check the need to change the oil and filter in the gearbox K66 (every 500 hours).</li></ol>	Notes

This field is intended for keeping a journal

---

# SERVICE JOURNAL

---

Action	Date, mileage reading, stamp, signature
<b>300-Hour Service</b>	
<ol style="list-style-type: none"><li>1. Inspect the machine. Additional work?</li><li>2. Change engine oil.</li><li>3. Change the air filter (Oil-foam element).</li><li>4. Change the air filter (paper filter).</li><li>5. Clean the fuel pump's air filter.</li><li>6. Check/adjust the cutting height.</li><li>7. Check/adjust the parking brake.</li><li>8. Inspect the flame proofing/spark extinguisher (extra equipment).</li><li>9. Change the engine's oil filter.</li><li>10. Clean/replace the spark plugs.</li><li>11. Change the inline fuel filter.</li><li>12. Clean the pulse air filter.</li><li>13. Check the play in the engine valves.</li><li>14. Check the need to change the oil and filter in the gearbox K66 (every 500 hours).</li></ol>	Notes

This field is intended for keeping a journal

---

# SERVICE JOURNAL

---

<b>Action</b>	<b>Date, mileage reading, stamp, signature</b>
<b>At Least Once Each Season</b>	
<ol style="list-style-type: none"><li>1. Change the engine oil (100 hours).</li><li>2. Clean/change the air cleaner's pre-filter (Oil-foam element) (25 hours). (shorter intervals for dusty operating conditions)</li><li>3. Clean/change the air cleaner's paper filter (100 hours). (shorter intervals for dusty operating conditions).</li><li>4. Clean the fuel pump's air filter (50 hours).</li><li>5. Adjust the cutting height (50 hours).</li><li>6. Adjust the parking brake (50 hours).</li><li>7. Inspect the flame proofing/spark extinguisher, extra equipment. (50 hours).</li><li>8. Replace the engine oil filter (200 hours).</li><li>9. Replace the hydraulic oil filter (200 hours).</li><li>10. Clean/change the spark plugs (100 hours).</li><li>11. Change the inline fuel filter (100 hours).</li><li>12. Clean the pulse air filter (100 hours).</li><li>13. Clean the cooling fins on the cylinders and cylinder head (100 hours). (shorter intervals for dusty operating conditions)</li><li>14. Check the play in the engine valves (300 hours).</li><li>15. Change the oil and filter in the gearbox K66 (500 hours).</li><li>16. Perform the 300-hour service at an authorised service representative.</li></ol>	Notes

This field is intended for keeping a journal









114 00 53-26



2002W10