

IPL, Kawasaki 15 hp, 2003-06, 106 27 25-62

FH430V

# Kawasaki 15 hp

**Spare parts**

**Ersatzteile**

**Pièces détachées**

**Reserve onderdelen**

**Repuestos**

**Reservdelar**

E0110-A383B

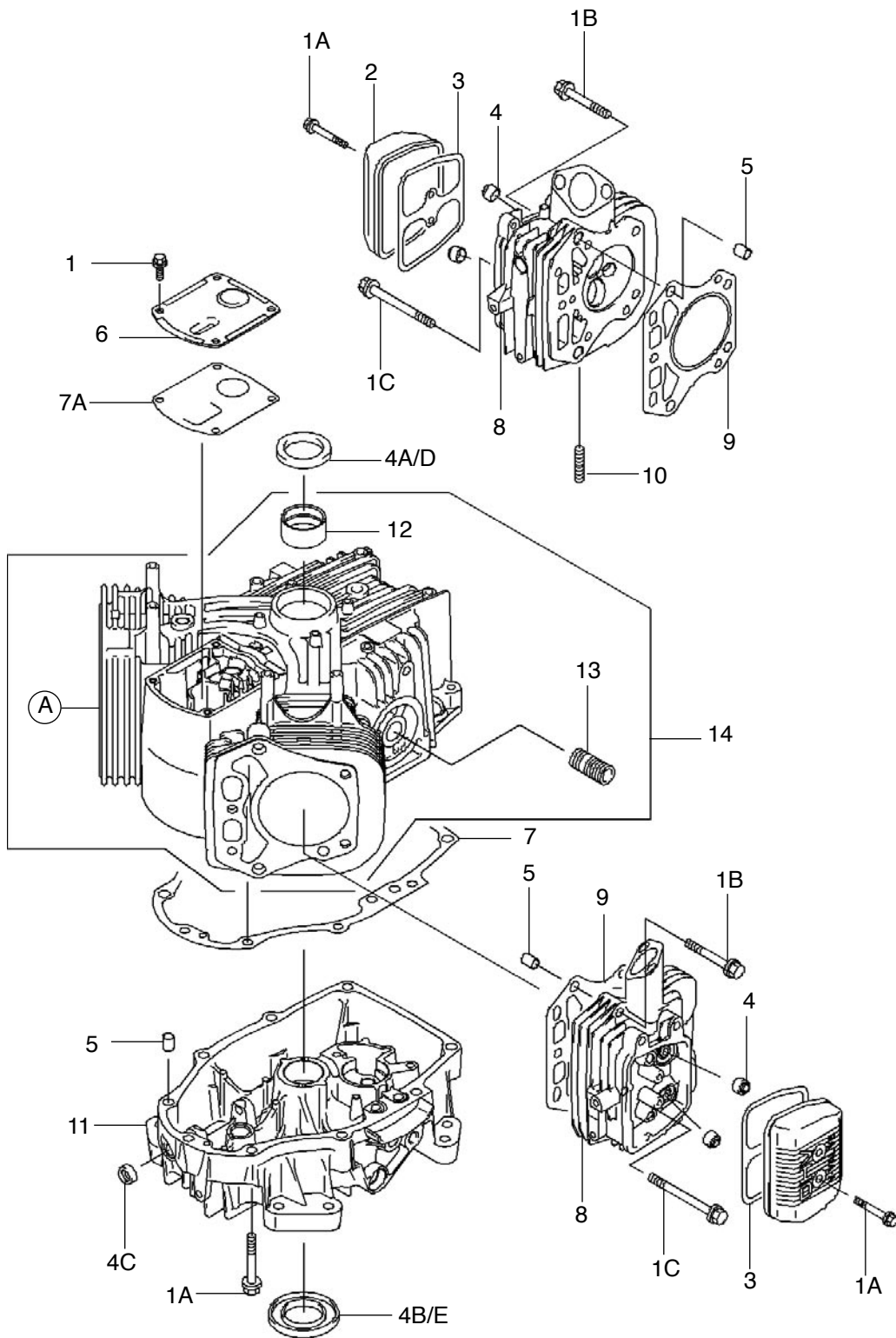

HQV REF.NO.	HQV PART NO.	DESCRIPTION	A
1	725 23 66-61	BOLT-FLANGED	4
1A	535 41 42-67	BOLT-FLANGED	4
1B	535 41 42-70	BOLT-FLANGED	17
1C	535 41 42-71	BOLT-FLANGED	2
2	535 41 42-16	CASE-ROCKER	2
3	535 41 42-22	GASKET,ROCKER CASE	2
4	535 41 44-49	SEAL-OIL,RVC2 6X11X10.2	4
4A	535 41 44-50	SEAL-OIL,35-48-8 TC	*
4B	535 41 44-51	SEAL-OIL,35-62-8 TC	*
4C	535 41 44-52	SEAL-OIL,SO 8X14X5 HS	1
4D	535 41 51-07	SEAL-OIL,SD 35X48X8 R HS	1
4E	535 41 44-51	SEAL-OIL,SD 35X62X8 L HS	1
5	535 41 44-46	PIN	6
6	535 41 45-70	COVER	1
7	535 41 45-57	GASKET,COVER-CRANKCASE	1
7A	535 41 45-58	GASKET,BREATHER	1
8	535 41 45-51	HEAD-COMP-CYLINDER,#1	1
8A	535 41 45-52	HEAD-COMP-CYLINDER,#2	1
9	535 41 45-50	GASKET-HEAD	2
10	535 41 45-07	BOLT-STUD	4
11	535 41 45-93	COVER-CRANKCASE	1
12	535 46 64-14	BUSHING	1
13	535 41 44-14	JOINT	1
14	535 41 45-97	CRANKCASE-COMP	1

E0120-A203A

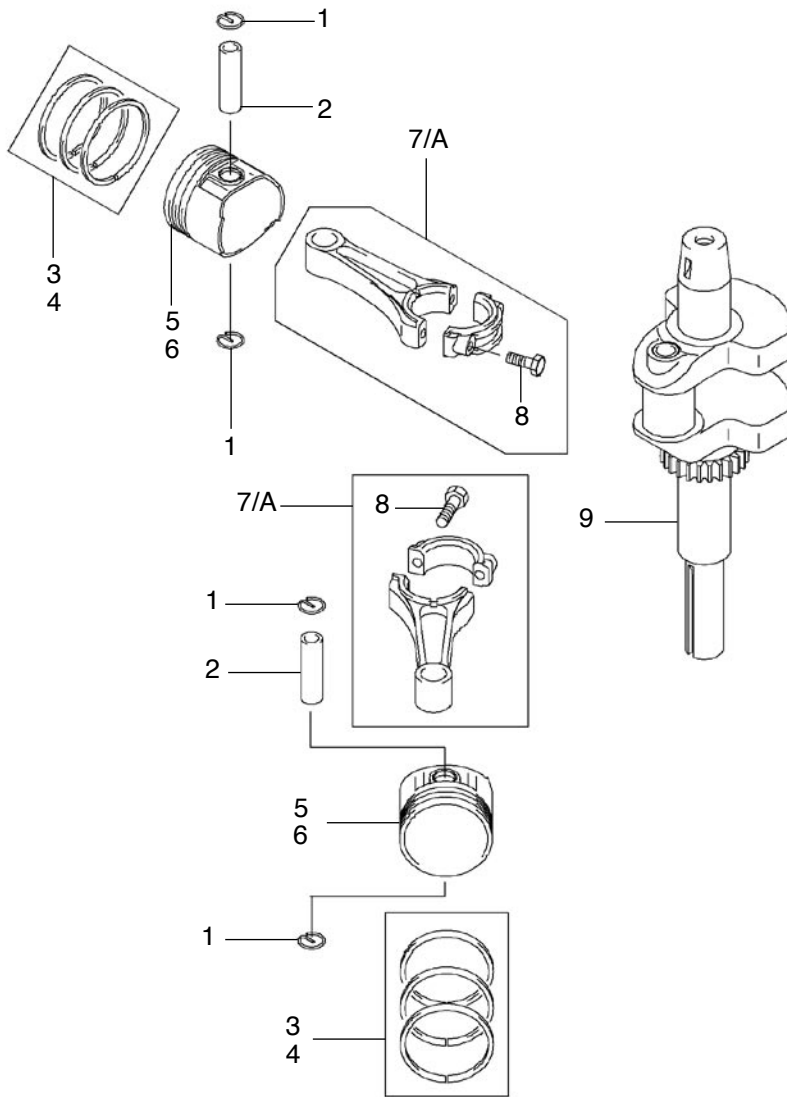

<b>HQV REF.NO.</b>	<b>HQV PART NO.</b>	<b>DESCRIPTION</b>	<b>A</b>
1	535 41 44-43	RING-SNAP	4
2	535 41 42-51	PIN-PISTON	2
3	535 41 45-62	RING-SET-PISTON	2
4	535 41 45-63	RING-SET-PISTON L,0.50	AR
5	535 41 45-61	PISTON-ENGINE	2
6	535 41 45-64	PISTON-ENGINE L,0.50	AR
7	535 41 45-68	ROD-ASSY-CONNECTING	2
7A	535 41 45-69	ROD-ASSY-CONNECTING,U/S=0.50	2
8	535 41 42-69	BOLT-FLANGED	4
9	535 41 45-65	CRANKSHAFT-COMP	1

E0130-A110A

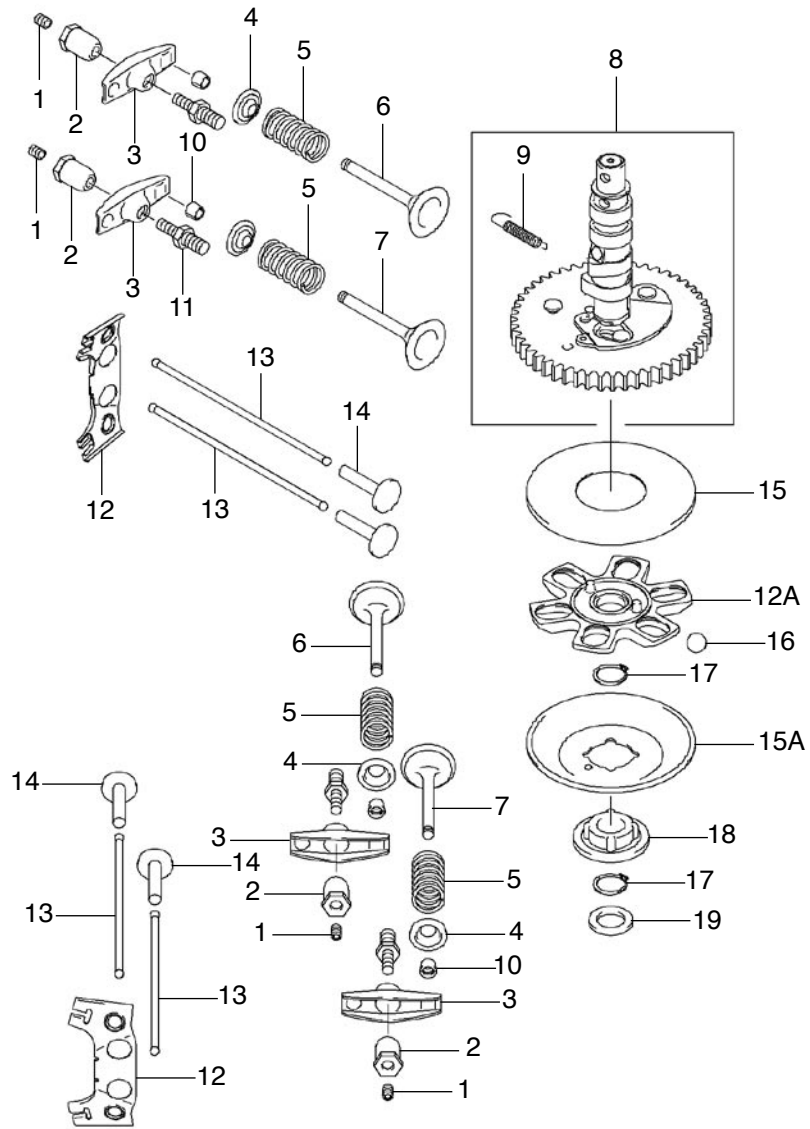

<b>HQV REF.NO.</b>	<b>HQV PART NO.</b>	<b>DESCRIPTION</b>	<b>A</b>
1	535 41 44-24	SCREW	4
2	531 00 01-81	NUT	4
3	535 41 42-46	ARM-ROCKER	4
4	535 41 42-44	RETAINER VALVE-SPRING	4
5	535 41 43-81	SPRING-ENGINE VALVE	4
6	535 41 42-41	VALVE-INTAKE	2
7	535 41 42-43	VALVE-EXHAUST	2
8	535 41 45-96	CAMSHAFT-COMP	1
9	535 41 44-73	SPRING	1
10	535 41 42-45	COLLET	4
11	535 41 51-05	BOLT	4
12	535 41 42-60	GUIDE	2
12A	535 41 42-61	GUIDE	1
13	535 41 42-76	ROD-PUSH	4
14	535 41 42-48	TAPPET	4
15	535 41 42-86	PLATE	1
15A	535 41 51-06	PLATE,GOVERNOR	1
16	535 41 44-70	BALL	6
17	535 41 44-40	RING-SNAP	2
18	535 41 43-69	SLEEVE	1
19	535 41 45-03	WASHER	1

E0140-A253A

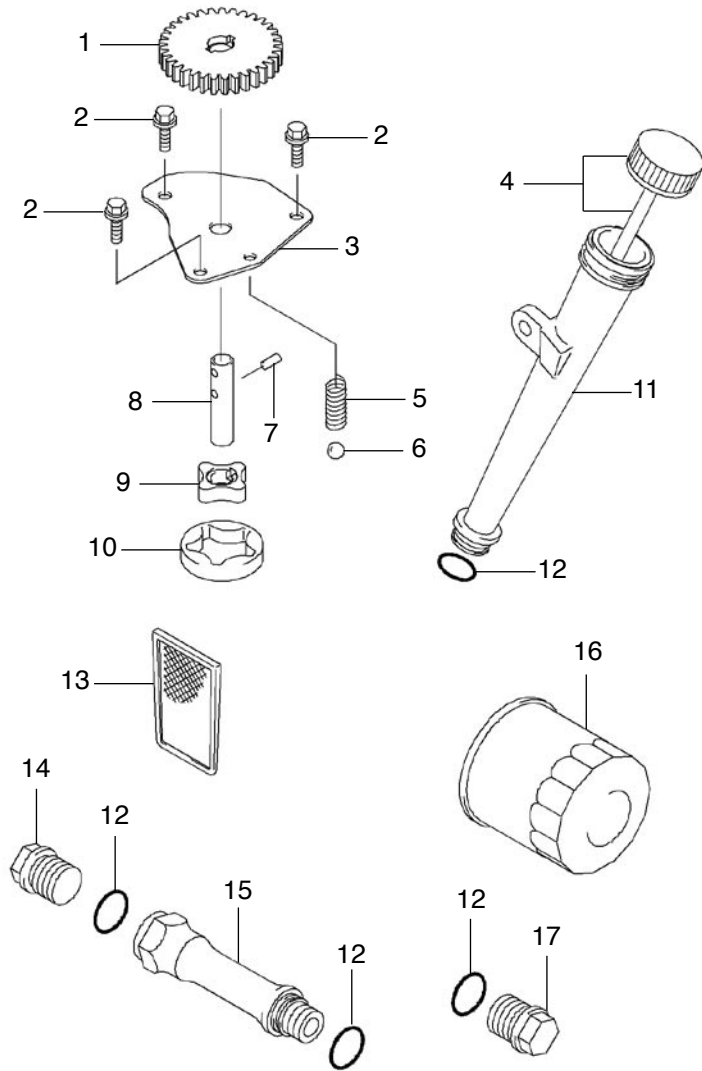



<b>HQV REF.NO.</b>	<b>HQV PART NO.</b>	<b>DESCRIPTION</b>	<b>A</b>
1	535 41 51-08	GEAR-SPUR	1
2	725 23 66-61	BOLT-FLANGED	3
3	535 41 42-88	PLATE	1
4	535 41 51-09	CAP-ASSY	1
5	535 41 44-74	SPRING	1
6	535 41 44-71	BALL	1
7	535 41 44-47	PIN	2
8	535 41 42-73	SHAFT	1
9	535 41 43-25	ROTOR-PUMP,IN	1
10	535 41 43-26	ROTOR-PUMP,OUT	1
11	535 46 64-04	FILLER	1
12	531 00 11-90	O RING,16MM	4
13	535 41 43-80	FILTER-OIL	1
14	535 41 44-60	PLUG	2
15	535 41 44-16	JOINT	1
16	535 41 45-21	FILTER-OIL	1



<b>HQV REF.NO.</b>	<b>HQV PART NO.</b>	<b>DESCRIPTION</b>	<b>A</b>
1	725 23 66-61	BOLT-FLANGED	9
1A	725 23 68-61	BOLT-FLANGED	2
1B	535 41 42-68	BOLT-FLANGED	1
2	535 41 51-10	SCREEN	1
3	535 41 51-11	BOLT	3
3A	535 41 51-12	BOLT	1
4	535 46 64-02	HOUSING-FAN	1
5	535 41 44-38	SPACER	1
6	535 41 51-13		
7	535 41 42-83	BRACKET-COMP	1
8	535 41 45-94	PLATE	1
8A	535 41 45-95	SHROUD-ENGINE,#2CYLINDER	1
9	535 41 44-09	SHROUD-ENGINE,#1CYLINDER	1
10	535 41 45-71	FAN COVER	1 1

E0160-A849A

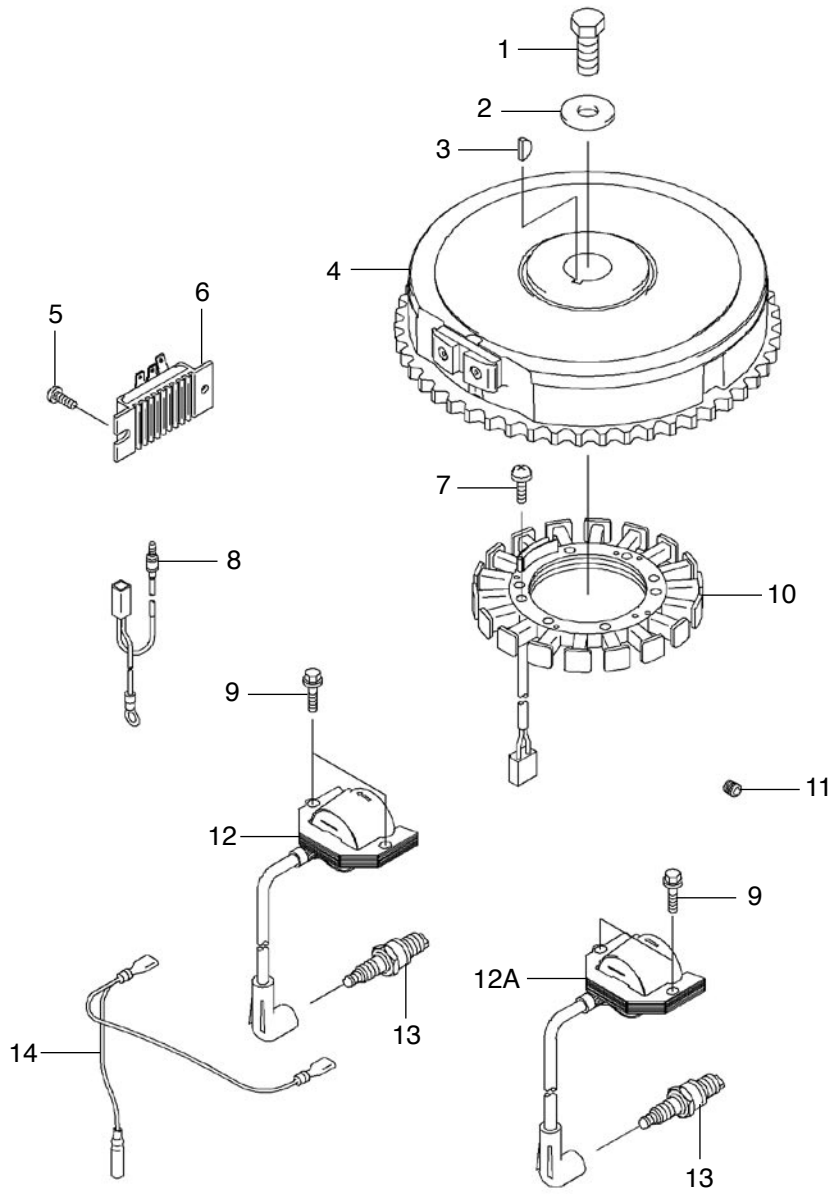

<b>HQV REF.NO.</b>	<b>HQV PART NO.</b>	<b>DESCRIPTION</b>	<b>A</b>
1	535 41 44-83	BOLT,12X30	1
2	535 41 45-04	WASHER	1
3	535 41 44-02	KEY-WOODRUFF	1
4	535 41 45-88	FLYWHEEL-ASSY	1
5	531 00 12-78	SCREW	1
6	535 41 43-40	REGULATOR-VOLTAGE	1
7	535 41 43-51	SCREW-PAN-WP-CROS	4
8	535 41 45-89	HARNESS	1
9	535 41 42-64	BOLT-FLANGED	4
10	535 41 44-08	COIL-CHARGING	1
11	535 41 44-59	PLUG	1
12	535 41 43-43	COIL-ASSY-IGNITION	1
12A	535 41 45-86	COIL-ASSY-IGNITION	1
13	535 41 44-63	PLUG-SPARK,RCJ8Y,SOLID	2
14	535 41 43-59	HARNESS	1

E0170-A422A

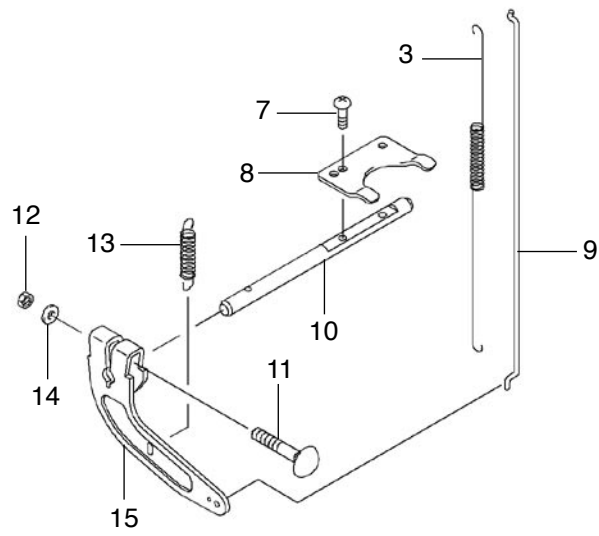
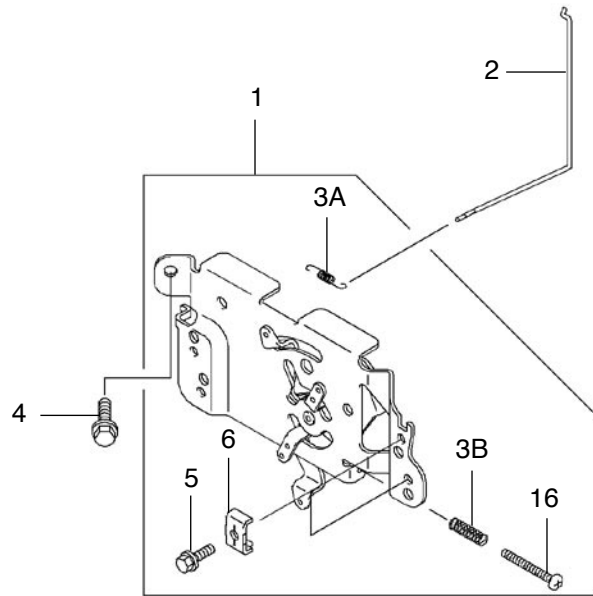

<b>HQV REF.NO.</b>	<b>HQV PART NO.</b>	<b>DESCRIPTION</b>	<b>A</b>
1	535 41 43-93	PANEL-COMP-CONTROL	1
2	535 41 45-80	LINK-CHOKE	1
3	535 41 44-75	SPRING	1
3A	535 41 44-77	SPRING	1
3B	535 41 44-78	SPRING	1
4	725 23 66-61	BOLT-FLANGED	2
5	535 41 44-82	BOLT,5X18	2
6	535 41 44-90	CLAMP	2
7	535 41 43-49	SCREW-PAN+-	2
8	535 41 42-89	PLATE	1
9	535 41 45-81	LINK	1
10	535 41 42-74	SHAFT	1
11	535 41 51-14	BOLT,6X35	1
12	535 41 45-32	NUT-HEX	1
13	535 41 43-65	SPRING-GOVERNOR	1
14	535 41 43-68	WASHER-PLAIN	1
15	535 41 51-15	ARM-GOVERNOR	1
16	535 41 51-16	SCREW,4X35	1

E0180-A526A

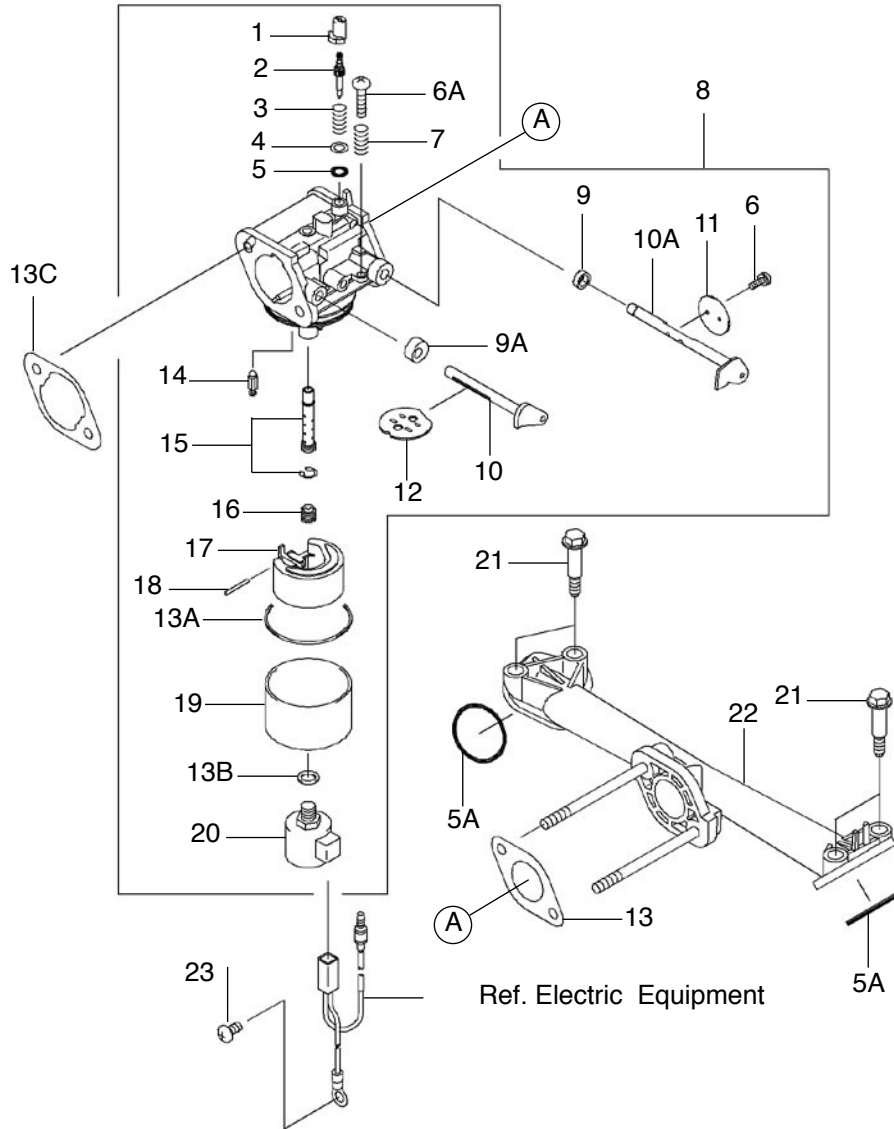



HQV REF.NO.	HQV PART NO.	DESCRIPTION	A
1	535 41 45-92	LIMITER	1
2	535 41 45-73	SCREW-PILOT AIR	1
3	535 46 64-15	SPRING	1
4	535 46 64-17	WASHER	1
5	535 46 64-08	RING-O	1
5A	535 46 64-09	RING-O,ID=31	2
6	535 46 64-06	SCREW	2
6A	535 46 64-07	SCREW	1
7	535 46 64-11	SPRING	1
8	535 41 45-72	CARBURETOR-ASSY	1
9	535 46 64-12	SEAL	1
9A	535 46 64-13	SEAL	1
10	535 41 45-78	SHAFT-CARBURETOR,CHOKE	1
10A	535 41 45-79	SHAFT-CARBURETOR,THROTTLE	1
11	535 41 45-75	VALVE-THROTTLE	1
12	535 41 45-82	VALVE-ASSY-CHOKE	1
13	535 41 51-17	GASKET,INSULATOR	1
13A	535 41 45-59	GASKET,CHAMBER	1
13B	535 41 45-60	GASKET	1
13C	535 41 51-18	GASKET,AIR CLEANER	1
14	535 41 45-76	VALVE-FLOAT	1
15	535 41 45-98	NOZZLE-MAIN	1
16	535 46 64-10	JET-MAIN,#88	1
17	535 41 45-77	FLOAT	1
18	535 41 45-67	SHAFT	1
19	535 41 45-74	CHAMBER-FLOAT	1
20	535 41 45-87	SOLENOID	1
21	535 46 64-16	BOLT	4
22	535 46 64-03	MANIFOLD-INTAKE	1
23	535 41 43-50	SCREW-PAN+-	1

E0190-A608A

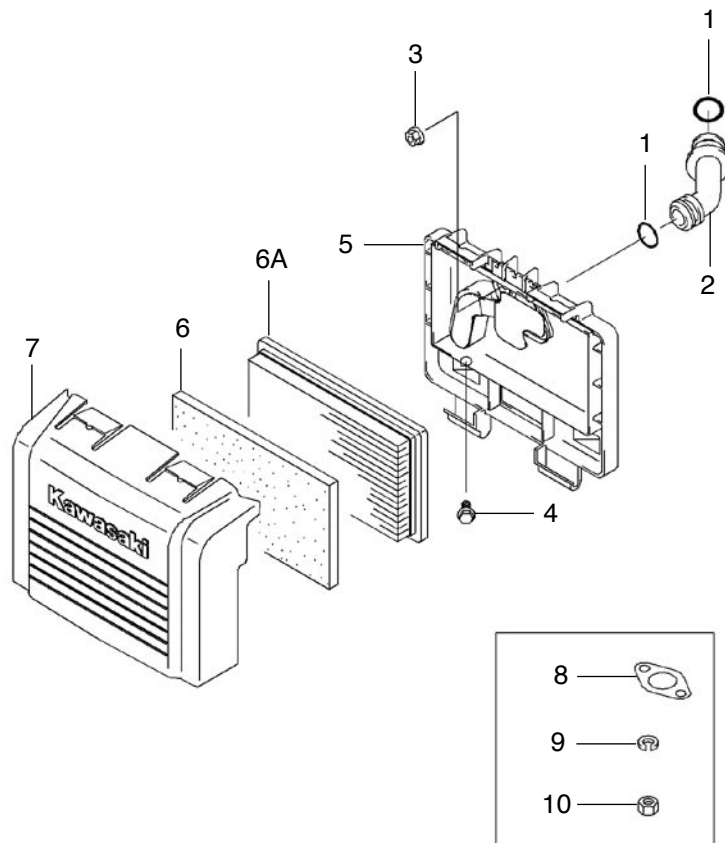

<b>HQV REF.NO.</b>	<b>HQV PART NO.</b>	<b>DESCRIPTION</b>	<b>A</b>
1	535 46 64-05	O RING,10MM	2
2	535 41 45-91	PIPE,BREATHER	1
3	535 41 44-32	NUT	2
4	535 41 51-11	BOLT	2
5	535 41 45-56	CASE-ASSY-AIR FILTER,LOWER	1
6	535 41 45-48	ELEMENT-AIR FILTER	1
6A	535 41 45-55	ELEMENT-AIR FILTER	1
7	535 41 45-53	CASE-AIR FILTER,UPPER	1
8	535 41 42-36	GASKET,MUFFLER	2
9	535 41 43-72	WASHER-SPRING	4
10	535 41 43-63	NUT-HEX-SMALL	4

E0200-A275A

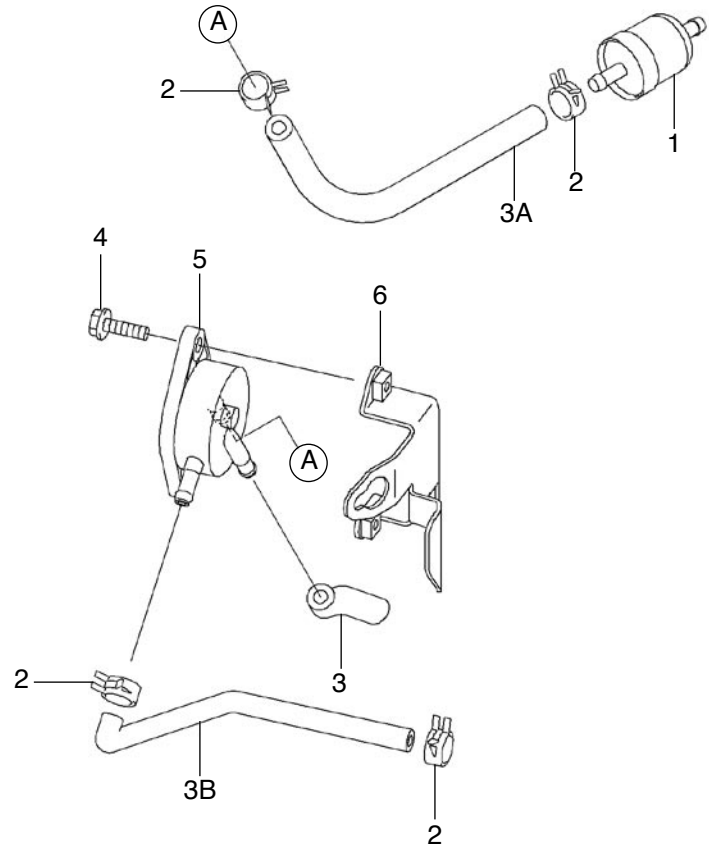

<b>HQV REF.NO.</b>	<b>HQV PART NO.</b>	<b>DESCRIPTION</b>	<b>A</b>
4	535 41 42-64	BOLT-FLANGED	2
6	535 41 43-52	BRACKET-COMP	1
1	535 41 43-76	FILTER-FUEL	1
5	535 41 45-45	PUMP-FUEL	1
2	535 41 44-89	CLAMP	4
3	535 41 44-94	TUBE	1
3A	535 41 44-95	TUBE,6.35X12.7X160	1
3B	535 41 44-96	TUBE	1

E0210-A254A

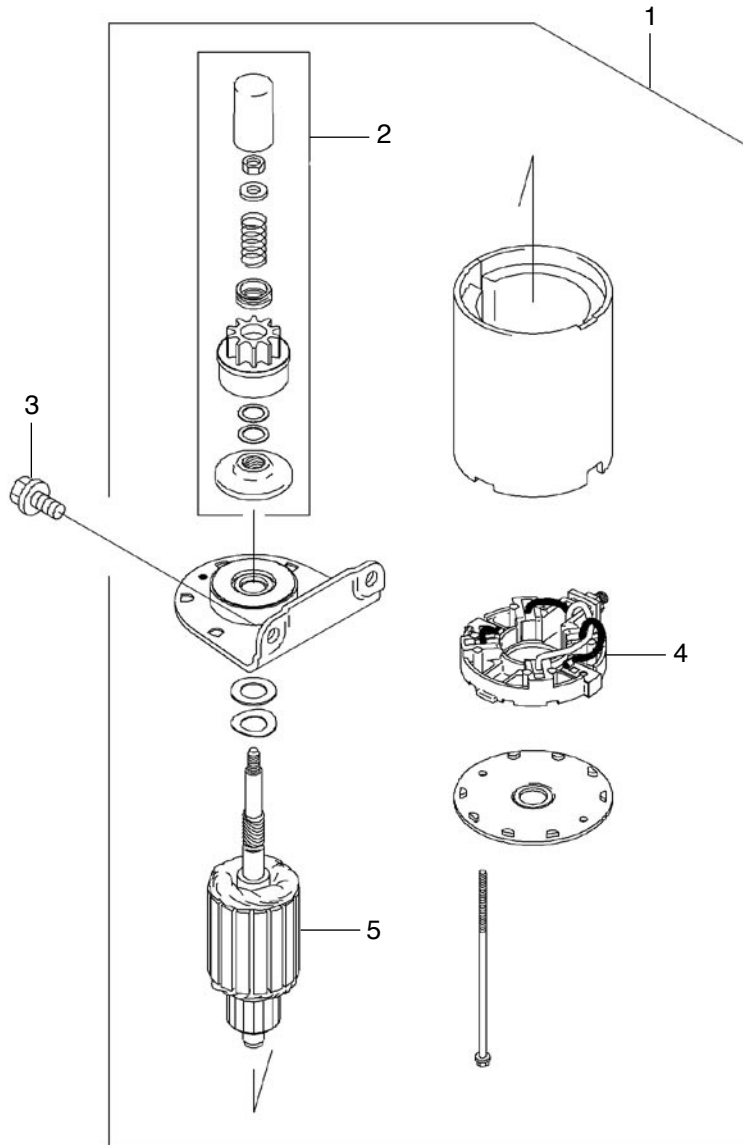

<b>HQV REF.NO.</b>	<b>HQV PART NO.</b>	<b>DESCRIPTION</b>	<b>A</b>
1	535 41 45-85	STARTER-ELECTRIC	1
2	535 41 45-66	GEAR-ASSY	1
3	535 41 42-68	BOLT-FLANGED	2
4	535 41 45-83	BRUSH	1
5	535 41 45-84	ARMATURE	1

1

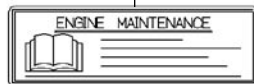

2

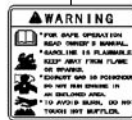

3

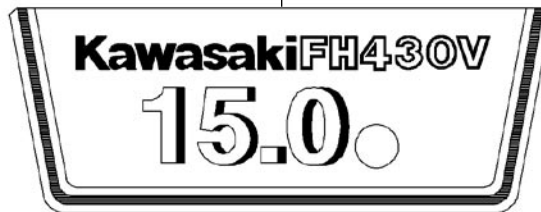



<b>HQV REF.NO.</b>	<b>HQV PART NO.</b>	<b>DESCRIPTION</b>	<b>A</b>
1	535 41 44-03	LABEL-MANUAL	1
2	535 41 45-99	LABEL-WARNING	1
3	535 46 64-01	LABEL-BRAND	1