

LTH135

Spare parts
Ersatzteile
Pièces détachées
Reserve onderdelen
Repuestos
Reservdelar

TRACTOR - MODEL NO. LTH135 (HELTH135C), PRODUCT NO. 954 17 00-80 SCHEMATIC

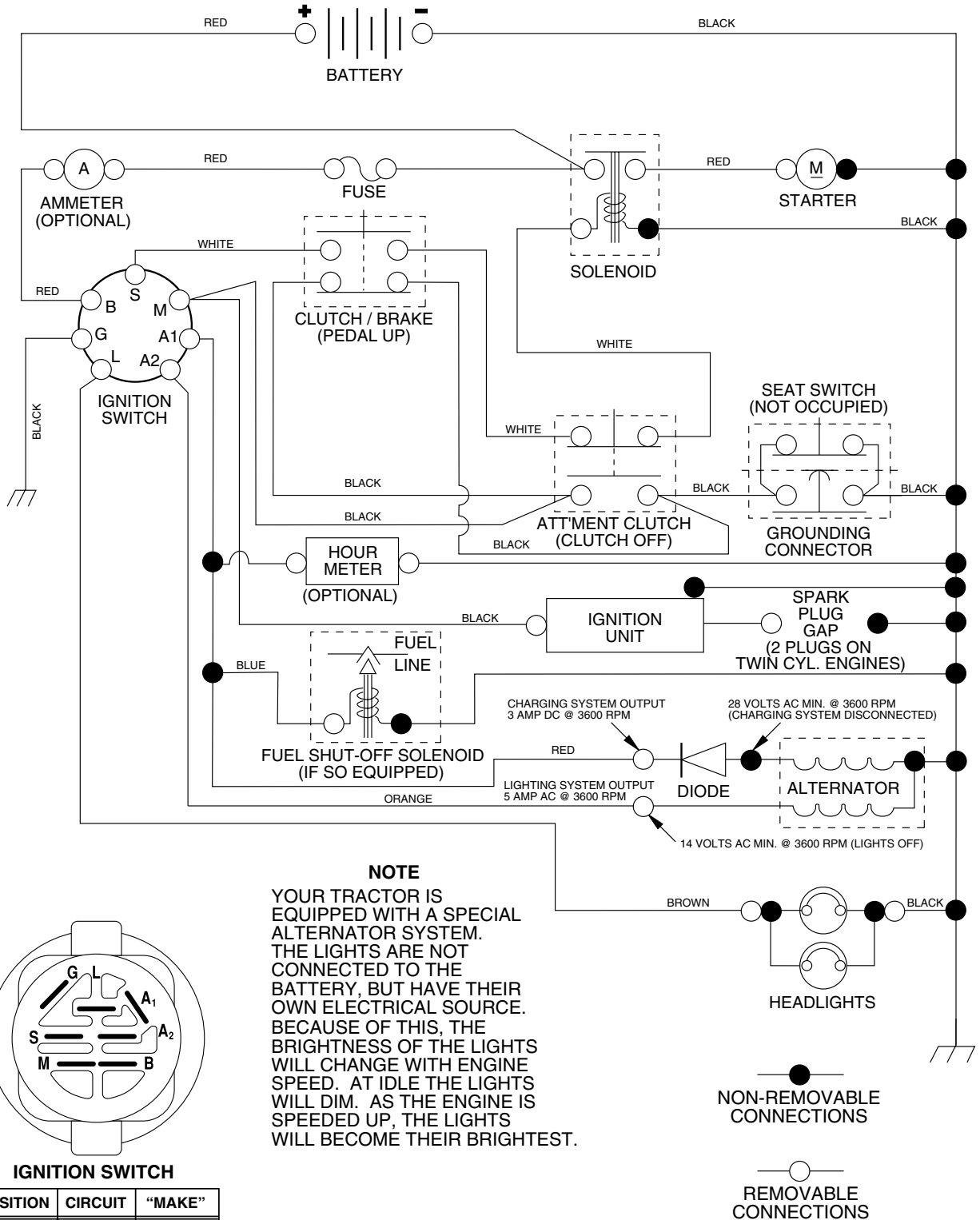

REPAIR PARTS

TRACTOR - MODEL NO. LTH135 (HELTH135C), PRODUCT NO. 954 17 00-80
ELECTRICAL

KEY NO.	PART NO.	DESCRIPTION
1	532 16 34-65	Battery
2	874 76 04-12	Bolt Hex Hd 1/4-20unc X 3/4
8	532 17 66-89	Case Battery Mech Hinge
16	532 17 61-38	Switch Interlock
21	532 17 56-88	Harness Asm Light W/4152j
22	532 00 41-52	Bulb Light #1156
24	532 12 47-80	Cable Battery 6 Ga 11" red
25	532 14 61-47	Cable Battery 6 Ga 44" red w/16 wire
26	532 17 51-58	Fuse 20 AMP
27	873 51 04-00	Nut Keps Hex 1/4-20 Unc
28	532 12 47-73	Cable Ground 6 Ga 12" black
29	532 12 13-05	Switch Plunger Nc Gray
30	532 17 55-66	Switch Ign
33	532 14 04-01	Key Ign Molded Generic
40	532 17 97-20	Harness Ign.
41	871 11 04-08	Bolt Blk Fin Hex 1/4 - 20 x 1/2
42	532 13 15-63	Cover Terminal Red
43	532 17 88-61	Solenoid
48	532 14 08-44	Adapter Ammeter Rectangular
52	532 14 19-40	Protection Wire Loop
90	532 18 04-49	Cover Terminal Battery

NOTE: All component dimensions given in U.S. inches.
1 inch = 25.4 mm.

REPAIR PARTS

TRACTOR - MODEL NO. LTH135 (HEALTH135C), PRODUCT NO. 954 17 00-80
CHASSIS AND ENCLOSURES

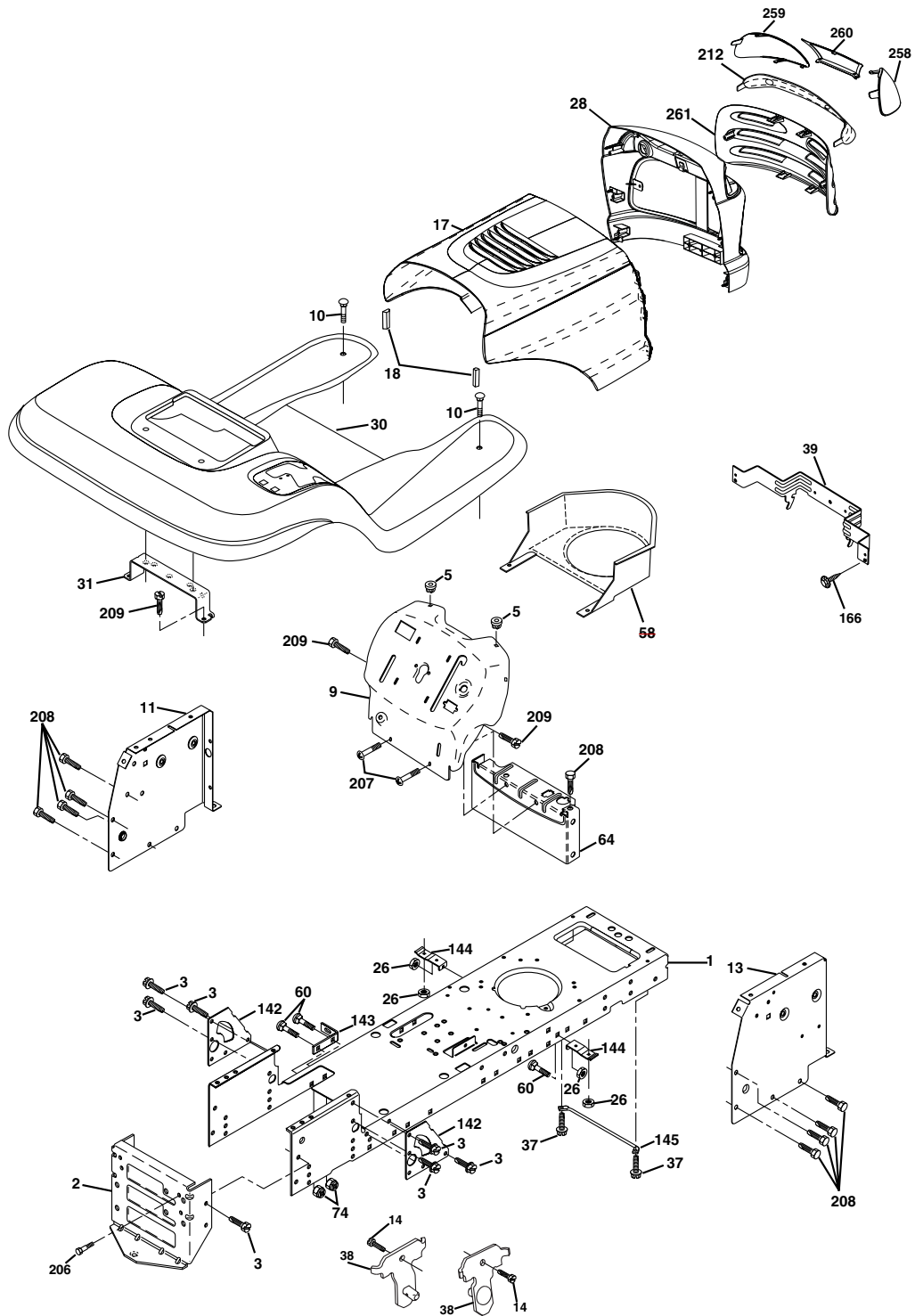

REPAIR PARTS

TRACTOR - MODEL NO. LTH135 (HELTH135C), PRODUCT NO. 954 17 00-80 CHASSIS AND ENCLOSURES

KEY NO.	PART NO.	DESCRIPTION
1	532 17 46-19	Chassis Stamping
2	532 17 65-54	Drawbar
3	817 06 06-12	Screw 3/8-16x3/4
5	532 15 52-72	Bumper Hood/Dash
9	532 17 18-53	Dash P/L
10	872 14 06-08	Bolt Carriage 3/8-16 x 1
11	532 17 49-96	Panel Dash Lh
13	532 18 17-19	Panel Dash Rh
14	817 49 06-08	Screw thdrol 3/8-16 x 1/2
17	532 18 52-11	Hood LT/PL Husqvarna
18	532 18 49-21	Bumper Hood
26	873 80 06-00	Nut Lock Hex W/Ins 3/8-16 Unc
28	532 18 35-38	Grille/Len Asm
30	532 18 05-07	Fender Footrest STLT Pnt
31	532 13 99-76	Bracket Support Fender
37	817 49 05-08	Screw Thdrol 6/16-18 x 1/2 TYT
38	532 17 57-10	Bracket, Asm. Pivot, Mower Rear
39	532 17 47-14	Bracket Pivot Laser
58	532 15 01-27	Air Duct Engine P/L
60	872 14 06-06	Bolt Rdhd Sqnk 3/8-16 Unc x 3/4
64	532 15 47-98	Dash Lower STLT
74	873 68 06-00	Nut Crownlock 3/8-16 Unc
142	532 17 57-02	Plate Reinforcement STLT
143	532 15 49-66	Bracket Swaybar Chassis
144	532 17 55-82	Bracket Pnt Footrest STLT
145	532 15 65-24	Rod Pivot Chassis/Hood
166	532 17 18-75	Screw HWHD Hi-Lo #13-16 x 3/4
206	532 17 01-65	Bolt Shoulder 5/16-18 TT
207	817 67 05-08	Screw Thdrol 5/16-18 x 1/2
208	817 67 06-08	Screw Thdrol 3/8-16 x 1/2
209	817 00 06-12	Screw Hex Wsh Thdrol 3/8-16- x 3/4
212	532 18 35-48	Insert Lens Reflect
258	532 18 52-13	Lens RH
259	532 18 52-14	Lens LH
260	532 18 52-16	Cover Lens
261	532 18 52-12	Insert Grille

NOTE: All component dimensions given in U.S. inches.
1 inch = 25.4 mm.

REPAIR PARTS

TRACTOR - MODEL NO. LTH135 (HELTH135C), PRODUCT NO. 954 17 00-80
DRIVE

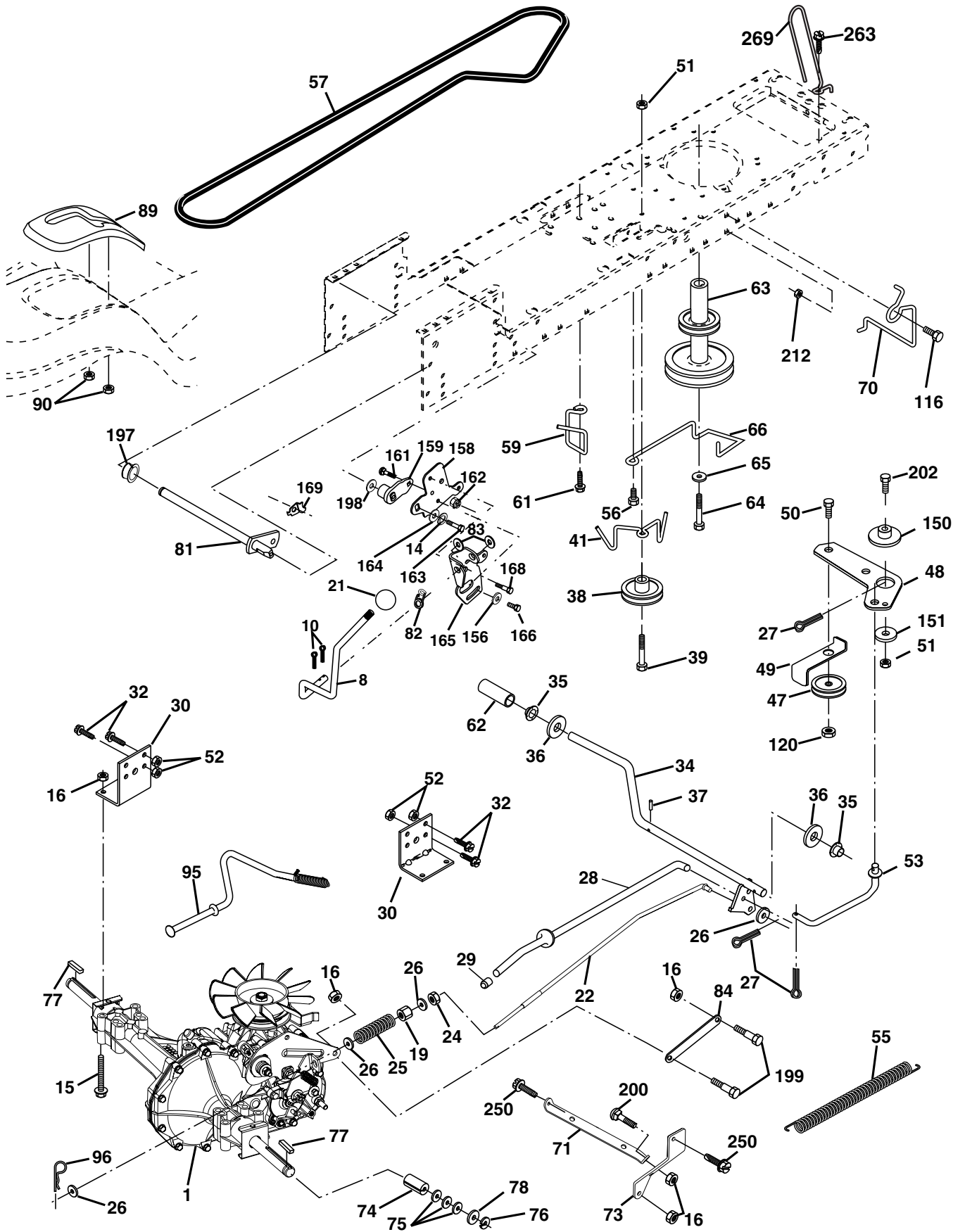

REPAIR PARTS

TRACTOR - MODEL NO. LTH135 (HELTH135C), PRODUCT NO. 954 17 00-80 DRIVE

KEY NO.	PART NO.	DESCRIPTION	KEY NO.	PART NO.	DESCRIPTION
1	-----	Transaxle Hydro Gr 322-0510 (Order parts from transaxle manufacturer)	74	532 13 70-57	Spacer, Axle
8	532 16 58-66	Rod Shift Fender STLT	75	532 12 17-49	Washer 25/32 x 1-1/4 x 16 Gauge
10	876 02 04-16	Pin Cotter 1/8 x 1 CAD	76	812 00 00-01	E-Ring
14	810 04 04-00	Washer Lock Hvy Helical 1/4	77	532 12 35-83	Key, Square
15	874 49 05-44	Bolt Hex Flg Hd 5/16-18 X Gr.5	78	532 12 17-48	Washer 25/32 x 1-5/8 x 16 Gauge
16	873 80 05-00	Nut Lock Hex W/Ins. 5/16-18 Unc P	81	532 16 55-96	Shaft Asm. Cross Hydro
19	873 80 06-00	Nut Lock Hex W/Wsh 3/8-16 Unc	82	532 16 57-11	Spring Torsion T/A
21	532 12 12-74	Knob	83	819 17 12-16	Washer 17/32 x 3/4 x 16 Ga.
22	532 16 94-98	Rod, Brake Hydro	84	532 16 98-43	Link Transaxle
24	873 35 06-00	Nut	89	532 16 65-10	Console, Shift
25	532 10 68-88	Spring, Brake Rod	90	532 12 43-46	Nut Self-Thd wsh-Hd 1/4 Zinc
26	819 13 13-16	Washer	95	532 17 02-01	Control Asm Bypass Hydro
27	876 02 04-12	Pin Cotter 1/8 x 3/4 CAD.	96	532 12 47-88	Retainer Spring 1" Zinc/Cad
28	532 17 57-65	Rod, Parking Brake	103	873 94 08-00	Nut Hex Jam Toplock 1/2-20 Unf
29	532 07 16-73	Cap, Parking Brake	116	872 14 06-08	Bolt Rdhd 3/8-16 x 1
30	532 17 49-73	Bracket, Transaxle	120	873 90 06-00	Nut Lock Flg 3/8-16
32	874 76 05-12	Bolt Hex Hd 5/16-18 Unc x 3/4	150	532 17 54-56	Spacer Retainer
34	532 17 55-78	Shaft, Foot Pedal, Nibbed	151	819 13 32-10	Washer 13/32 x 2 x 10 Ga.
35	532 12 01-83	Bearing, Nylon	156	532 16 60-02	Washer Srrtd 5/16 ID x 1.0 x .125 Tk
36	819 21 16-16	Washer	158	532 16 55-89	Bracket Shift Mount
37	532 12 49-63	Pin, Roll	159	532 16 54-94	Hub Tapered Flange Shift LT
38	532 17 91-14	Pulley, Composite, Flat	161	872 14 04-06	Bolt Rdhd Sqnk 1/4-20 x 3/4 Gr. 5
39	874 76 06-48	Bolt Fin Hex 3/8-16 Unc x 3	162	873 68 04-00	Nut Crownlock 1/4-20 Unc
41	532 17 55-56	Keeper, Belt Idler	163	874 78 04-16	Bolt Hex Fin 1/4-20 unc x 1 Gr. 5
47	532 12 77-83	Pulley, Idler, V-Groove	164	819 09 10-10	Washer 5/8 x .281 x 10 Ga
48	532 15 44-07	Bellcrank Clutch Grnd Drv Stl	165	532 16 56-23	Bracket Pivot Lever
49	532 12 32-05	Retainer, Belt	166	532 16 68-80	Screw 5/16-18 x 5/8 TT Yellow
50	872 11 06-12	Bolt 3/8-16 x 1-1/2 Gr. 5	168	532 16 54-92	Bolt Shoulder 5/16-18 x .561 TT
51	873 68 06-00	Nut Crownlock 3/8-16	169	532 16 55-80	Plate Fastening Cross Shf. STLT/ CRD
52	873 68 05-00	Nut Crownlock 5/16-18	197	532 16 96-13	Nyliner Snap-In 5/8" ID
53	532 10 57-10	Link, Clutch	198	532 16 95-93	Washer Nyl 7/8 ID x .105 HYD CRD
55	532 10 57-09	Spring, Return, Clutch	199	532 16 96-12	Bolt Shoulder 5/16-18 Unc
56	817 06 06-20	Screw 3/8-16 x 1	200	872 14 05-08	Bolt Rdhd Sqnk 5/16-18 Unc x 1
57	532 14 02-94	V-Belt, Ground Drive	202	872 11 06-14	Bolt Carr 3/8-16 x 1-3/4 Gr. 5
59	532 16 96-91	Keeper, Center Span	205	819 17 16-16	Washer 17/32 x 1 x 16 Ga.
61	817 12 06-14	Screw 3/8-16 x 3/4	212	532 14 52-12	Nut Hex Flange Lock
62	532 12 48-72	Cover, Pedal	250	817 06 06-12	Screw 3/8-16 x .75 SNGML Tap R
63	532 18 02-19	Pulley, Eng	263	817 00 06-12	Screw 3/8-16 x 3/4
64	871 17 07-64	Bolt Hex 7/16-20 x 4 Ga. 5	269	532 18 24-02	Guard Muffler RH
65	810 04 07-00	Washer			
66	532 15 47-78	Keeper Belt Engine			
70	532 18 02-18	Guide Belt Mower Drive RH			
71	532 16 91-83	Strap Torque Lh Hydro			
73	532 16 91-82	Strap Torque Rh Hydro			

NOTE: All component dimensions given in U.S. inches.
1 inch = 25.4 mm.

REPAIR PARTS

TRACTOR - MODEL NO. LTH135 (HELTH135C), PRODUCT NO. 954 17 00-80
STEERING ASSEMBLY

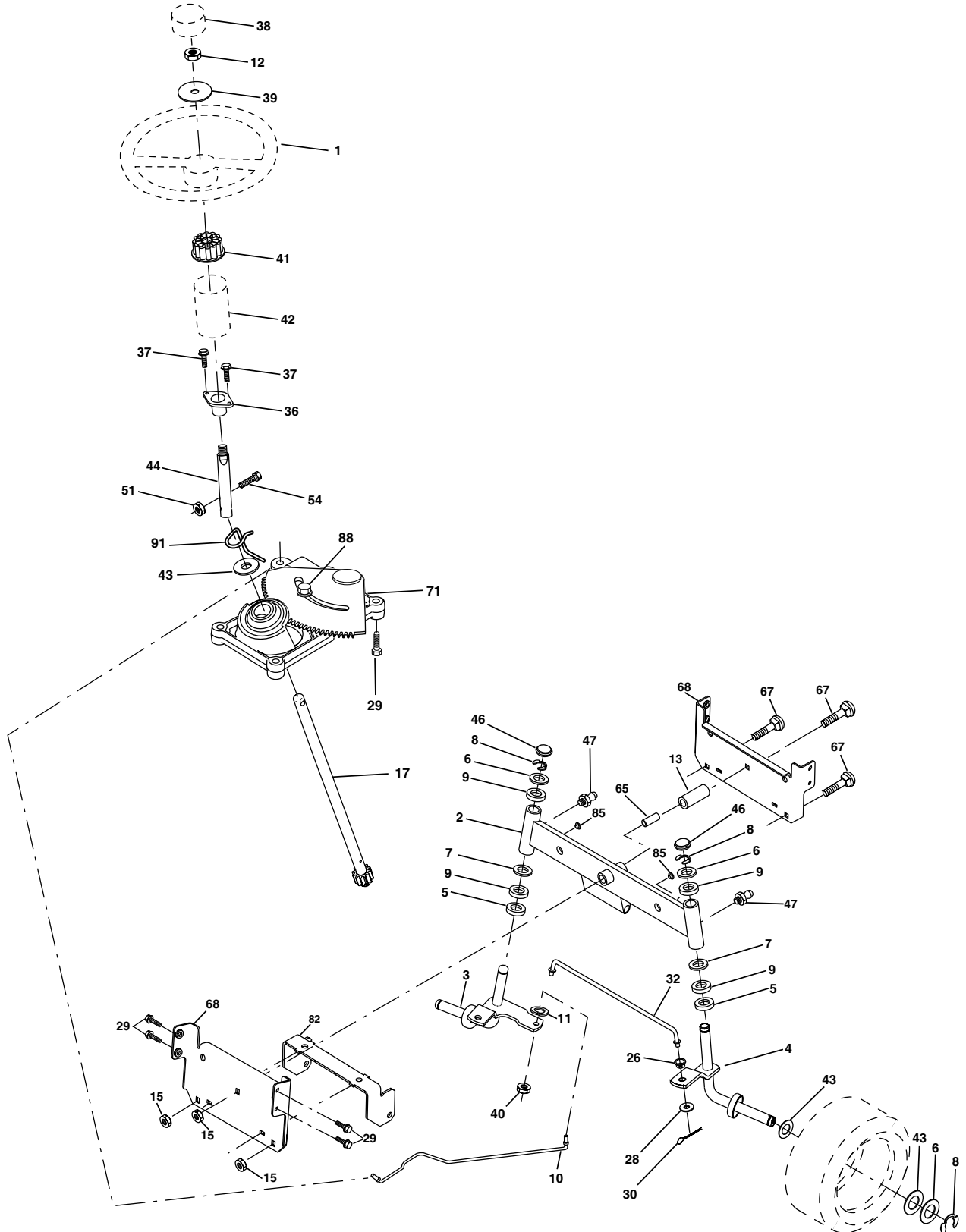

REPAIR PARTS

TRACTOR - MODEL NO. LTH135 (HELTH135C), PRODUCT NO. 954 17 00-80 STEERING ASSEMBLY

KEY NO.	PART NO.	DESCRIPTION
1	532 18 54-37	Wheel Steering
2	532 17 51-31	Axle Asm STMP Dropped STL
3	532 16 98-40	Spindle Asm LH
4	532 16 98-39	Spindle Asm RH
5	532 12 49-31	Bearing Race Thrust Harden
6	532 12 17-48	Washer 25/32 X 1-5/8 X 16 Ga
7	819 27 20-16	Washer 27/32 X 1-1/4 X 16 Ga
8	812 00 00-29	Ring Klip #t5304-75
9	532 12 49-37	Bearing Col Strg Blk
10	532 17 51-21	Link Drag
11	810 04 06-00	Washer Lock Hvy Hlcl Spr 3/8
12	873 94 08-00	Nut Hex Jam Toplock 1/2-20
13	532 13 65-18	Spacer Brg Axle Front
15	532 14 52-12	Nut Hex Flange Lock
17	532 18 06-41	Shaft Asm Strg
26	532 12 68-47	Bushing Link Drag Blk LR
28	819 13 14-16	Washer 13/32 X 7/8 X 16 Ga
29	817 06 06-12	Screw 3/8-16x3/4
30	876 02 04-12	Pin Cotter 1/8 X 3/4 Cad
32	532 13 04-65	Rod Tie Wire Form 19 75 Mech
36	532 15 50-99	Bushing Strg
37	532 15 29-27	Screw
38	532 16 66-26	Insert Cap Strg Wh
39	819 18 24-11	Washer 9/16 x 1-1/2 12 G.
40	532 12 47-01	Lock nut
41	532 15 99-45	Adaptor Wheel Strg
42	532 16 96-34	Boot Steering Shaft
43	532 12 17-49	Washer 25/32 X 1 1/4 X 16 Ga
44	532 18 06-40	Extension Steering Shaft LR/LT
46	532 12 12-32	Cap Spindle Fr Top Blk
47	532 18 32-26	Fitting Grease
51	873 54 04-00	Nut 1/4-28
54	871 13 04-20	Bolt Hex 1/4-28 x 1-1/4
65	532 16 03-67	Spacer Brace Axle
67	872 14 06-18	Bolt, Rdhd Sqnk 3/8-16 x 2-1/4
68	532 16 98-27	Axle, Brace
71	532 17 51-46	Steering Asm.
82	532 16 98-35	Bracket Susp Chassis Front
85	532 13 38-35	Fastener Christmas Tree
88	532 17 51-18	Bolt Shoulder 7/16-20
91	532 17 55-53	Clip Steering

NOTE: All component dimensions given in U.S. inches.
1 inch = 25.4 mm.

REPAIR PARTS

TRACTOR - MODEL NO. LTH135 (HEALTH135C), PRODUCT NO. 954 17 00-80
ENGINE

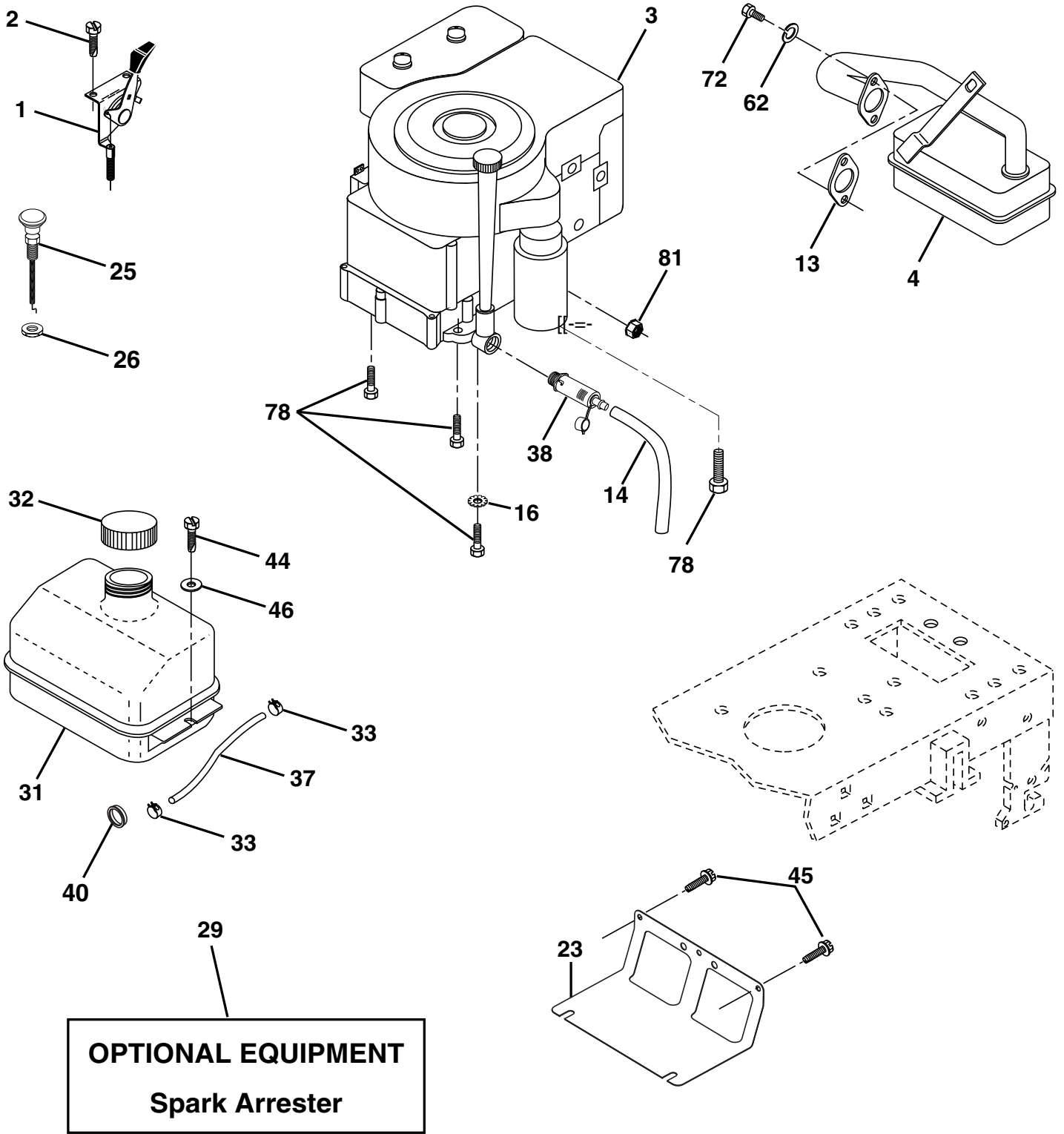

REPAIR PARTS

TRACTOR - MODEL NO. LTH135 (HELTH135C), PRODUCT NO. 954 17 00-80
ENGINE

KEY NO.	PART NO.	DESCRIPTION
1	532 17 05-51	Control Th/ch Flag
2	817 72 04-08	Screw Hex Thd Cut 1/4-20x5/8 T
3	-----	Engine Briggs & Stratton 31G777 (Order Parts From Engine Manufacturer)
4	532 13 73-52	Muffler LT B&S 12/12.5/13HP
13	532 16 52-91	Gasket Eng 1 313 Id Tin Plated
14	532 14 84-56	Tube Drain Oil Easy
16	811 05 06-00	Washer Lock Ext Tooth 3/8
23	532 16 98-37	Shield Brn/Dbr Guard
25	532 18 09-45	Control Choke 1 Cyl. 02
26	873 92 06-00	Nut Keps 3/8-24 Unf
29	532 13 71-80	Kit Spark Arrestor (Flat Scrn)
31	532 10 92-02	Tank Fuel Front
32	532 14 05-27	Cap Asm Fuel W/sym Vented
33	532 12 34-87	Clamp Hose Black
37	532 13 70-40	Line Fuel 20"
38	532 18 16-54	Plug Drain Oil Easy
40	532 12 40-28	Bushing Snap Nyl Blk Fuel Line
44	817 67 04-12	Screw Hexwsh Thdrol 1/4-20x3/4
45	817 00 06-12	Screw Hex Wsh Thdrol 3/8-16 x 3/4
46	819 09 14-16	Washer 9/32 X 7/8 X 16 Ga
62	810 04 05-00	Washer Lock Hvy Hlcl Spr 5/16
72	871 07 05-12	Screw Hexhd Cap 5/16-18 x 3/4
78	817 06 06-20	Screw 3/8-16x1-1/4
81	873 51 04-00	Nut 1/4-20

NOTE: All component dimensions given in U.S. inches.
1 inch = 25.4 mm.

REPAIR PARTS

TRACTOR - MODEL NO. LTH135 (HEALTH135C), PRODUCT NO. 954 17 00-80 SEAT ASSEMBLY

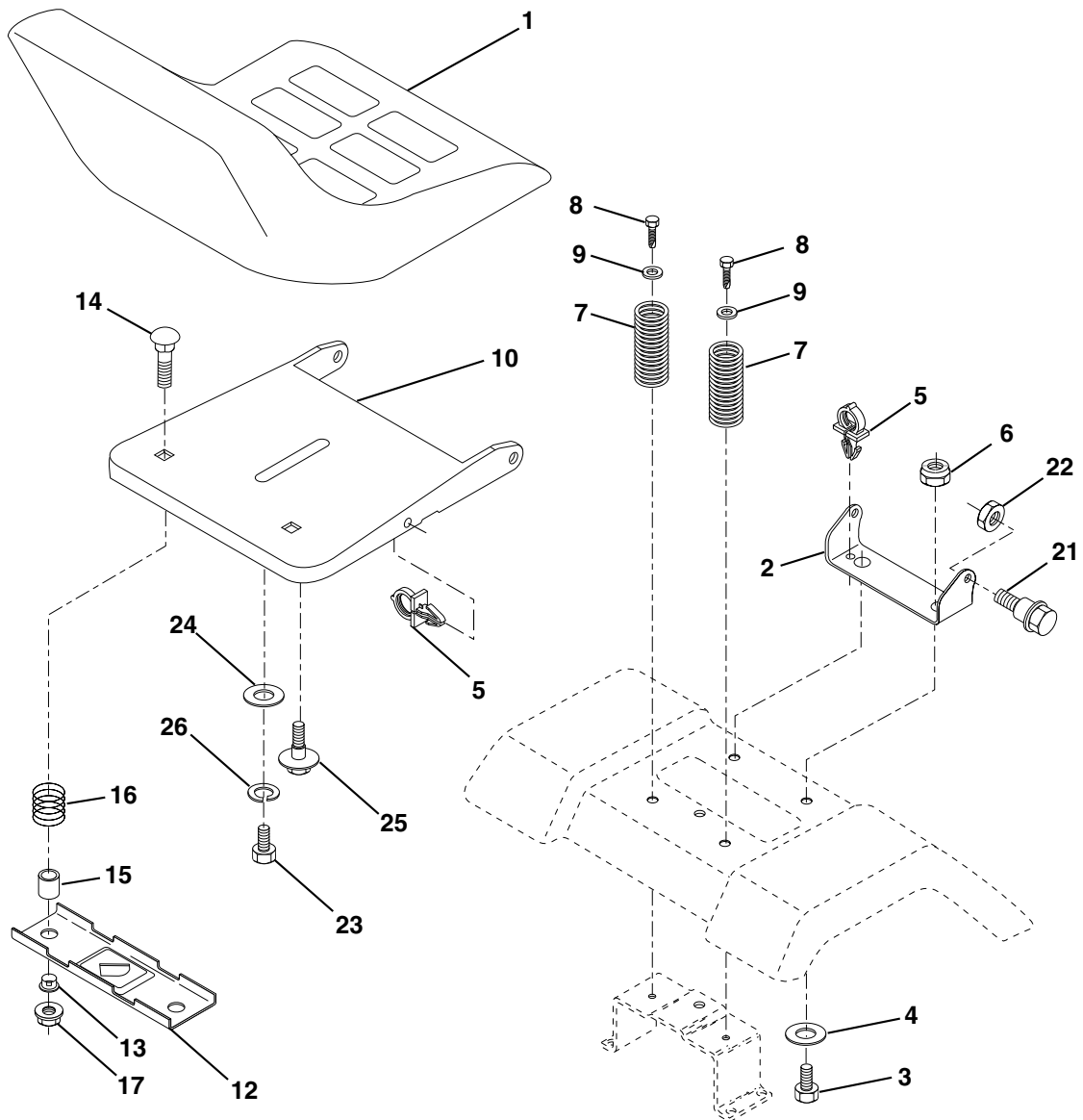

KEY NO.	PART NO.	DESCRIPTION
1	532 18 49-92	Seat
2	532 14 05-51	Bracket Pivot Seat 8 720
3	871 11 06-16	Bolt Fin Hex 3/8-16unc X 1
4	819 13 16-10	Washer 13/32 X 1 X 10 Ga
5	532 14 50-06	Clip Push-In
6	873 80 06-00	Nut Hex w/Ins. 3/8-16 Unc
7	532 12 41-81	Spring Seat Cprsn 2 250 Blk Zi
8	817 00 06-16	Screw 3/8-16 X 1-1/2
9	819 13 16-14	Washer 13/32 X 1 X 14 Ga.
10	532 18 24-93	Pan Seat
12	532 12 12-46	Bracket Mounting Switch
13	532 12 12-48	Bushing Snap Blk Nyl 50 Id

KEY NO.	PART NO.	DESCRIPTION
14	872 05 04-12	Bolt Rdhd Sqnk 1/4-20 x1-1/2
15	532 13 43-00	Spacer Split 28x 96 Yel Zinc
16	532 12 12-50	Spring Cprsn 1 27 Blk Pnt
17	532 12 39-76	Nut Lock 1/4 Lge Flg Gr 5 Zinc
21	532 17 18-52	Nut Lock 1/4 Lge Flg Gr 5 Zinc
22	873 80 05-00	Nut Hex Lock W/Ins 5/16-18
23	871 11 08-14	Bolt Hex
24	819 17 19-12	Washer 17/32 x 1-3/16 x 12 Ga.
25	532 12 70-18	Bolt Shoulder 5/16-18 X 62
26	810 04 08-00	Washer Lock Hvy HLCL SPR 1/2

NOTE: All component dimensions given in U.S. inches.
1 inch = 25.4 mm.

REPAIR PARTS

TRACTOR - MODEL NO. LTH135 (HEALTH135C), PRODUCT NO. 954 17 00-80
DECALS

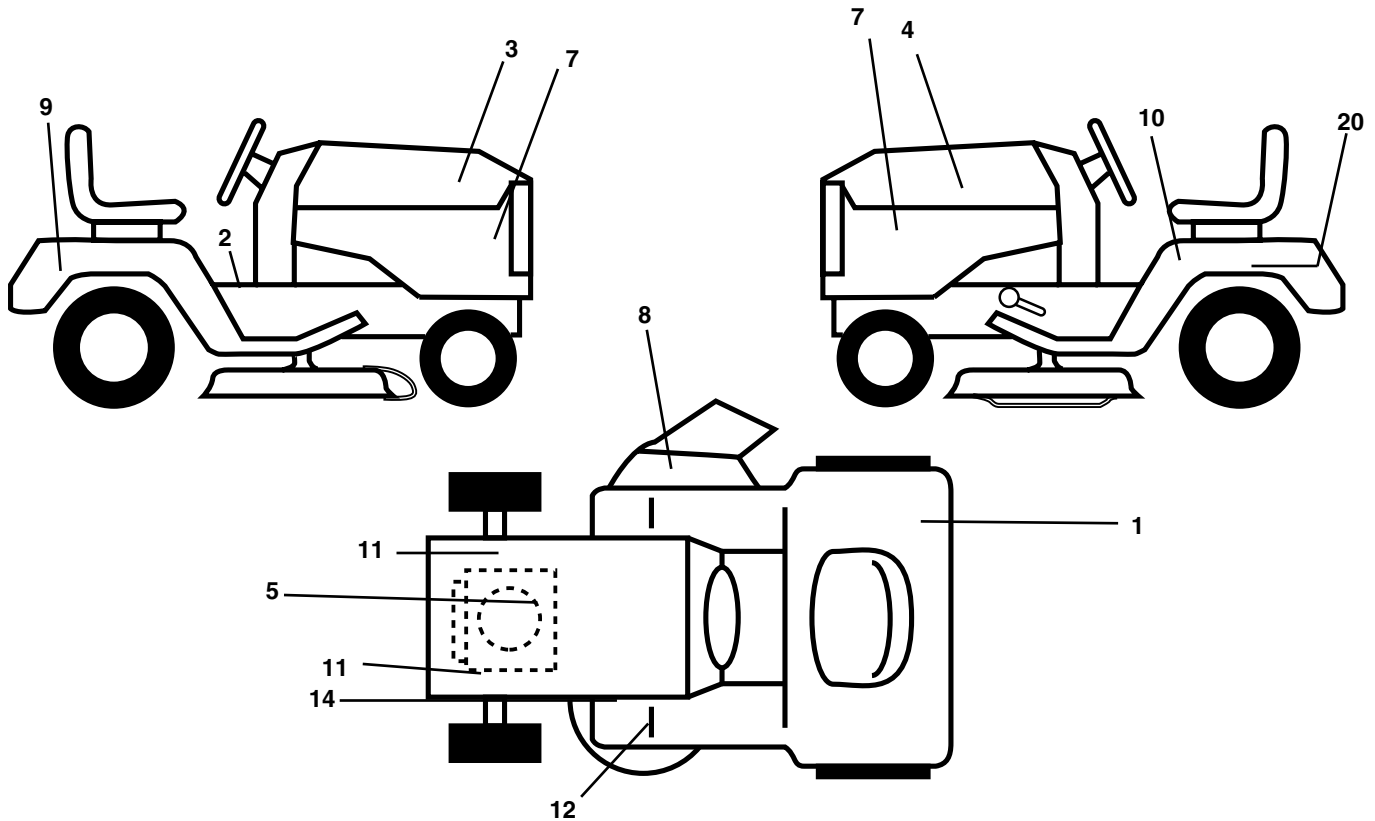

KEY NO.	PART NO.	DESCRIPTION
1	532 18 04-32	Decal 100 DB/CE
2	532 14 08-37	Decal Saddle Brake Parking
3	532 18 48-83	Decal Hood RH
4	532 18 48-84	Decal Hood LH
5	532 18 04-31	Decal HP Engine
7	532 15 97-13	Decal Pnl Side
8	532 18 21-66	Decal Mower Cuttinger
9	532 15 06-17	Decal Fender Husq
10	532 14 54-98	Decal Read Owner's Manual Syms.

KEY NO.	PART NO.	DESCRIPTION
11	532 15 97-36	Decal Chassis Hot Muffler
12	532 15 97-37	Decal Brake/ Clutch Symbol Lt
14	532 13 68-32	Decal V-Belt Schematic
20	532 14 50-05	Decal Bat Dan/Psn
--	532 17 12-84	Pad Footrest LH STLT
--	532 16 25-98	Decal Drawbar
--	532 17 12-85	Pad Footrest RH STLT
--	532 13 83-11	Decal Handle Lift Height Adjust
--	532 16 92-10	Decal Bypass Lt Hydro
--	532 18 57-21	Manual Operator's (Euro.)
--	532 18 57-22	Manual Operator's (Scan.)

WHEELS & TIRES

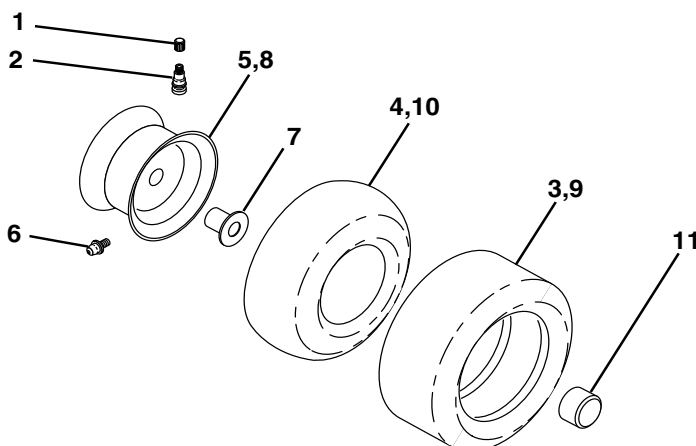

KEY NO.	PART NO.	DESCRIPTION
1	532 05 91-92	Cap Valve Tire
2	532 06 51-39	Stem Valve
3	532 10 62-22	Tire F Ts 15 X 6 0 - 6 Service
4	532 05 99-04	Tube Front (Service Item Only)
5	532 13 83-36	Rim Asm 6"front Silver Service
6	532 12 49-57	Fitting Grease (Front Wheel Only)
7	532 12 49-59	Bearing Flange (Front Wheel Only)
8	532 13 83-37	Rim Asm 8"rear Silver Service
9	532 12 46-35	Tire R Ts 18x9 5-8 C Service
10	532 12 49-26	Tube Rear (Service Item Only)
11	532 17 50-39	Cap Axle Blk 1 50 X 1 00
--	532 14 43-34	Sealant, Tire (10 oz. Tube)

NOTE: All component dimensions given in U.S. inches.
1 inch = 25.4 mm.

REPAIR PARTS

TRACTOR - MODEL NO. LTH135 (HELTH135C), PRODUCT NO. 954 17 00-80 MOWER DECK

KEY NO.	PART NO.	DESCRIPTION	KEY NO.	PART NO.	DESCRIPTION
1	532 17 45-95	Mower Deck Assembly	67	532 10 69-32	Knob RD 3/8-16 Plstc Thd
2	872 14 05-06	Bolt	68	532 18 02-13	Belt
3	532 13 80-17	Bracket Assembly,Sway Bar	89	819 13 16-12	Washer 13/32 x 1 x 12 Ga
4	532 17 56-54	Bracket Sway Bar	92	873 80 06-00	Nut Lock Hex w/Ins 3/8-16 Unc
5	532 12 46-70	Retainer Spring	107	532 13 35-02	Spacer, Retainer
6	532 17 80-24	Bar Sway Deck	108	532 13 35-03	Stiffener, Idler Arm
7	532 14 06-08	Keeper Belt	113	817 49 05-08	Screw Thdrol 5/16-18 x 1/2
8	532 85 08-57	Bolt, Hex 3/8-24 x 1.25 Gr. 8	122	532 17 45-05	Rod, Brake, LH
9	810 03 06-00	Washer, Lock Hvy Hlcl 3/8	123	532 17 45-04	Rod, Brake, RH
10	532 14 02-96	Washer, Hardened	129	819 13 13-12	Washer 13/32 x 13/16 x 12 Ga.
11	532 13 84-96	Blade, Mower	130	874 78 06-16	Bolt Fin Hex 3/8-16 Unc x 1 Gr. 5
13	532 13 76-45	Shaft Assembly, Mandrel, Vented	131	872 14 06-08	Bolt Rdhd Sqnk 3/8-16 Unfc x 1
14	532 12 87-74	Housing, Mandrel, Vented	146	532 16 58-91	Bolt Carriage Idler
15	532 11 04-85	Bearing, Ball, Mandrel	148	532 16 90-22	Spring Return Idler
16	532 17 44-93	Stripper, Vented Mower Deck	149	532 16 58-98	Retainer Spring Yellow Zinc
19	532 13 28-27	Bolt, Shoulder	150	819 09 12-16	Washer 9/32 x 3/4 x 16 Ga.
21	873 68 05-00	Nut Crownlock 5/16-18	151	532 16 96-70	Bracket Clutch
23	532 13 66-31	Bracket, Mower Deflector	152	532 17 60-79	Cable Clutch
24	532 10 53-04	Cap, Sleeve	153	532 16 96-74	Washer Flat 3/8" Type B
25	532 12 37-13	Spring, Torsion, Deflector	154	532 16 96-75	Spring Retainer
26	532 11 04-52	Nut, Push	155	532 16 96-71	Spring Retention Lever
27	532 17 61-62	Shield, Deflector	156	532 16 96-72	Spacer
28	819 11 10-16	Washer 11/32 x 5/8 x 16 Ga.	157	532 16 96-69	Rod Clutch
29	532 12 19-80	Rod, Hinge	158	817 72 04-08	Screw Hex Thd Cut 1/4-20x5/8
30	532 17 39-84	Screw Thdrol Washer Head	164	532 17 49-76	Bracket Asm Idler Support
31	532 12 99-63	Washer, Spacer	168	532 17 23-77	Bracket Deck Cable
32	532 15 35-31	Pulley, Mandrel	169	532 17 49-77	Bracket Asm Suspension
33	532 17 83-42	Nut, Toplock, Flanged	170	532 17 23-59	Bracket Suspension RF
34	872 11 06-14	Bolt Rdhd 3/8-16 x 1-3/4	171	532 16 52-37	Bracket Support Susp. Frt
36	532 13 14-94	Pulley, Idler, Flat	172	532 17 23-55	Bracket Suspension LF
40	873 68 06-00	Nut Crownlock 3/8-16	--	532 13 07-94	Mandrel Assembly (Includes Housing Shaft and Shaft Hardware Only - Pulley Not Included)
45	532 12 47-88	Retainer, Spring	--	532 18 13-76	Replacement Mower, Complete
53	532 13 08-40	Brake Assembly			
54	532 17 85-15	Washer, Hardened			
55	532 13 38-40	Idler Arm Assembly			
56	532 16 57-23	Spacer, Retainer			

NOTE: All component dimensions given in U.S. inches.
1 inch = 25.4 mm.

REPAIR PARTS

TRACTOR - MODEL NO. LTH135 (HEALTH135C), PRODUCT NO. 954 17 00-80
MOWER LIFT

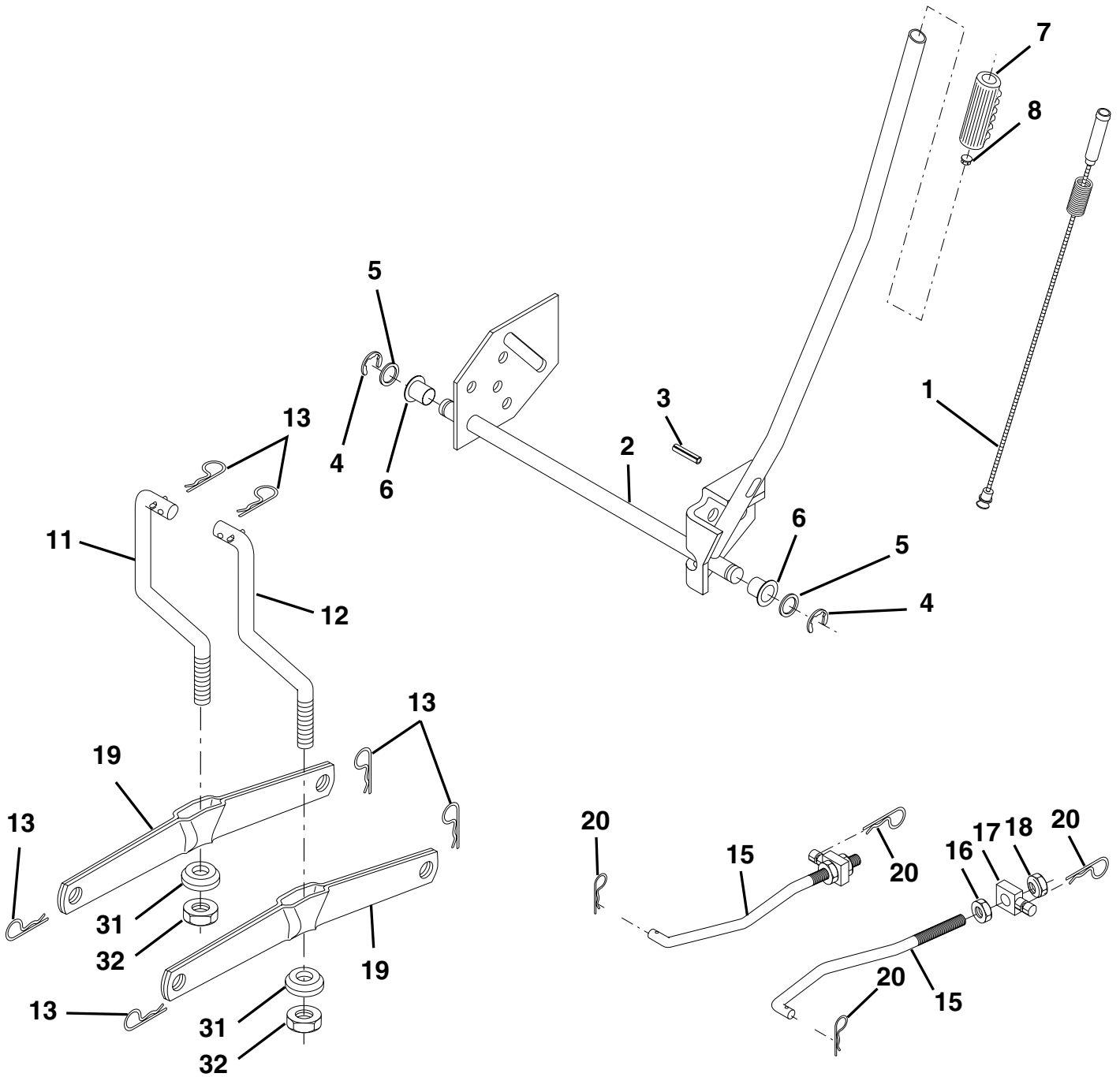

REPAIR PARTS

TRACTOR - MODEL NO. LTH135 (HELTH135C), PRODUCT NO. 954 17 00-80
MOWER LIFT

KEY NO.	PART NO.	DESCRIPTION
1	532 15 94-60	Wire Asm Inner/Spring W/plunger
2	532 15 94-71	Shaft Asm Lift
3	532 10 57-67	Pin Groove
4	812 00 00-02	E Ring #5133-62
5	819 21 16-21	Washer PLTD 21/32 X 1 X 21ga
6	532 12 01-83	Bearing Nylon Blk 629 Id
7	532 10 94-13	Grip Handle Bicycle
8	532 12 45-26	Button Plunger Black
11	532 13 98-65	Link Lift LH
12	532 13 98-66	Link Lift RH
13	532 12 46-70	Retainer Spring
15	532 17 32-88	Link Front
16	873 35 08-00	Nut Jam Hex 1/2-13 Unc
17	532 17 56-89	Trunnion Blk Zinc
18	873 80 08-00	Nut Lock W/wsh 1/2-13unc
19	532 13 98-68	Arm Suspension Rear
20	532 16 35-52	Spring, Retainer
31	532 16 98-65	Bearing Pvt. Lift
32	873 54 06-00	Nut Crownlock 3/8-24

NOTE: All component dimensions given in U.S. inches.
1 inch = 25.4 mm.