

# YTH210 XP

**Spare parts**

**Ersatzteile**

**Pièces détachées**

**Reserve onderdelen**

**Repuestos**

**Reservdelar**

# TRACTOR - MODEL NO. YTH210 XP(HEYTH210KA), PRODUCT NO. 954 17 00-75 SCHEMATIC

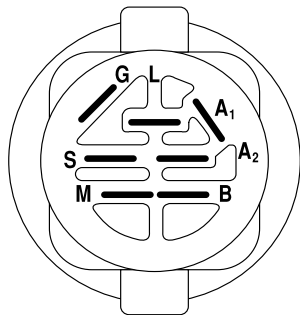
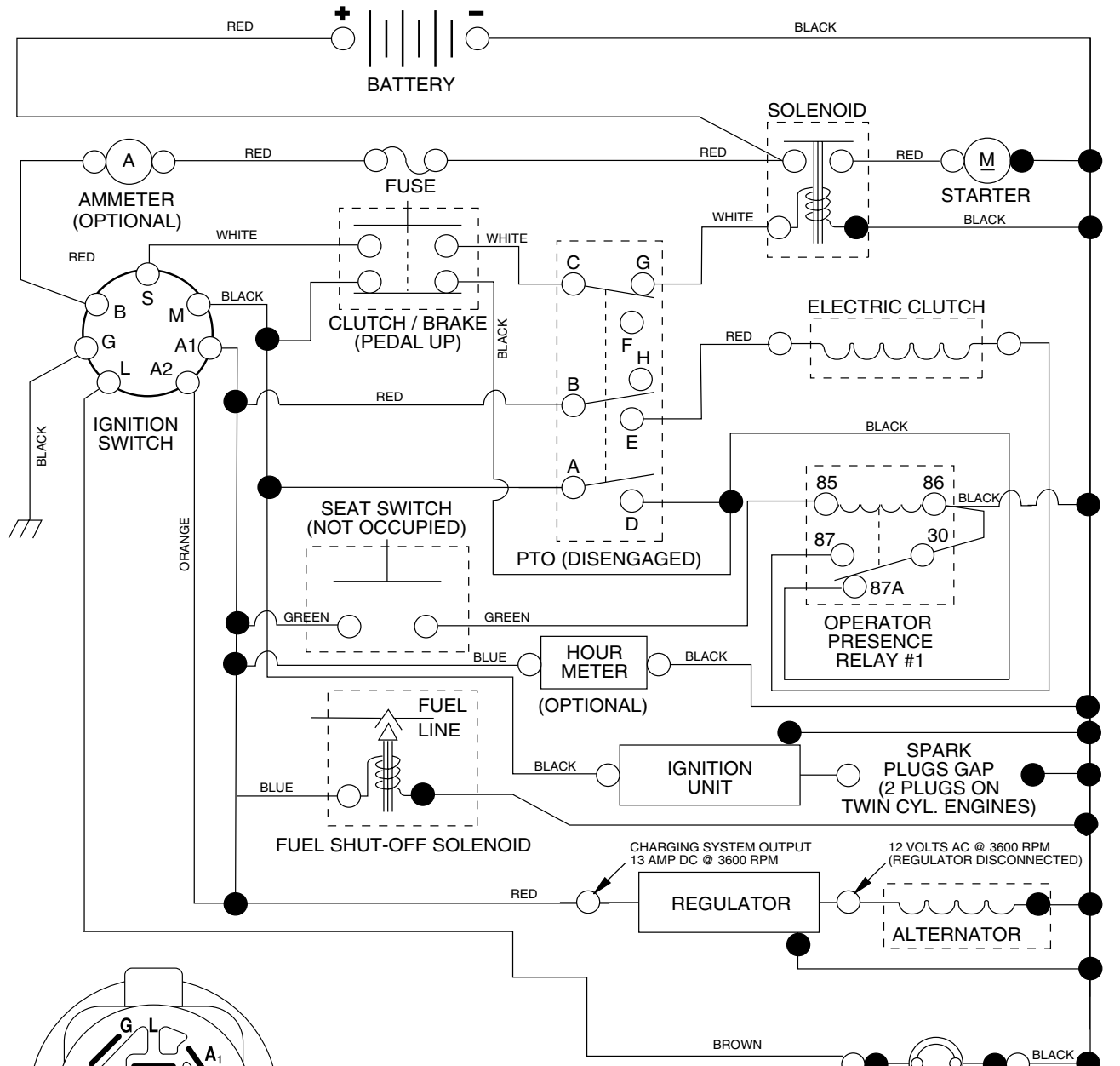

**IGNITION SWITCH**

POSITION	CIRCUIT	"MAKE"
OFF	M+G+A1	NONE
RUN/LIGHT	B+A1	A2+L
RUN	B+A1	NONE
START	B + S + A1	NONE

**WIRING INSULATED CLIPS**  
NOTE: IF WIRING INSULATED CLIPS WERE REMOVED FOR SERVICING OF UNIT, THEY SHOULD BE REPLACED TO PROPERLY SECURE YOUR WIRING.

**PTO SWITCH**

POSITION	CIRCUIT
OFF	C + G, B + H
ON	C + F, B + E, A + D

● NON-REMOVABLE CONNECTIONS  
○ REMOVABLE CONNECTIONS

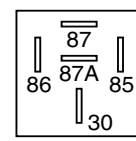

**RELAY**

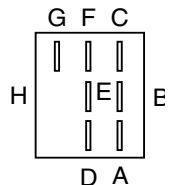

# REPAIR PARTS

TRACTOR - MODEL NO. YTH210 XP(HEYTH210KA), PRODUCT NO. 954 17 00-75  
ELECTRICAL

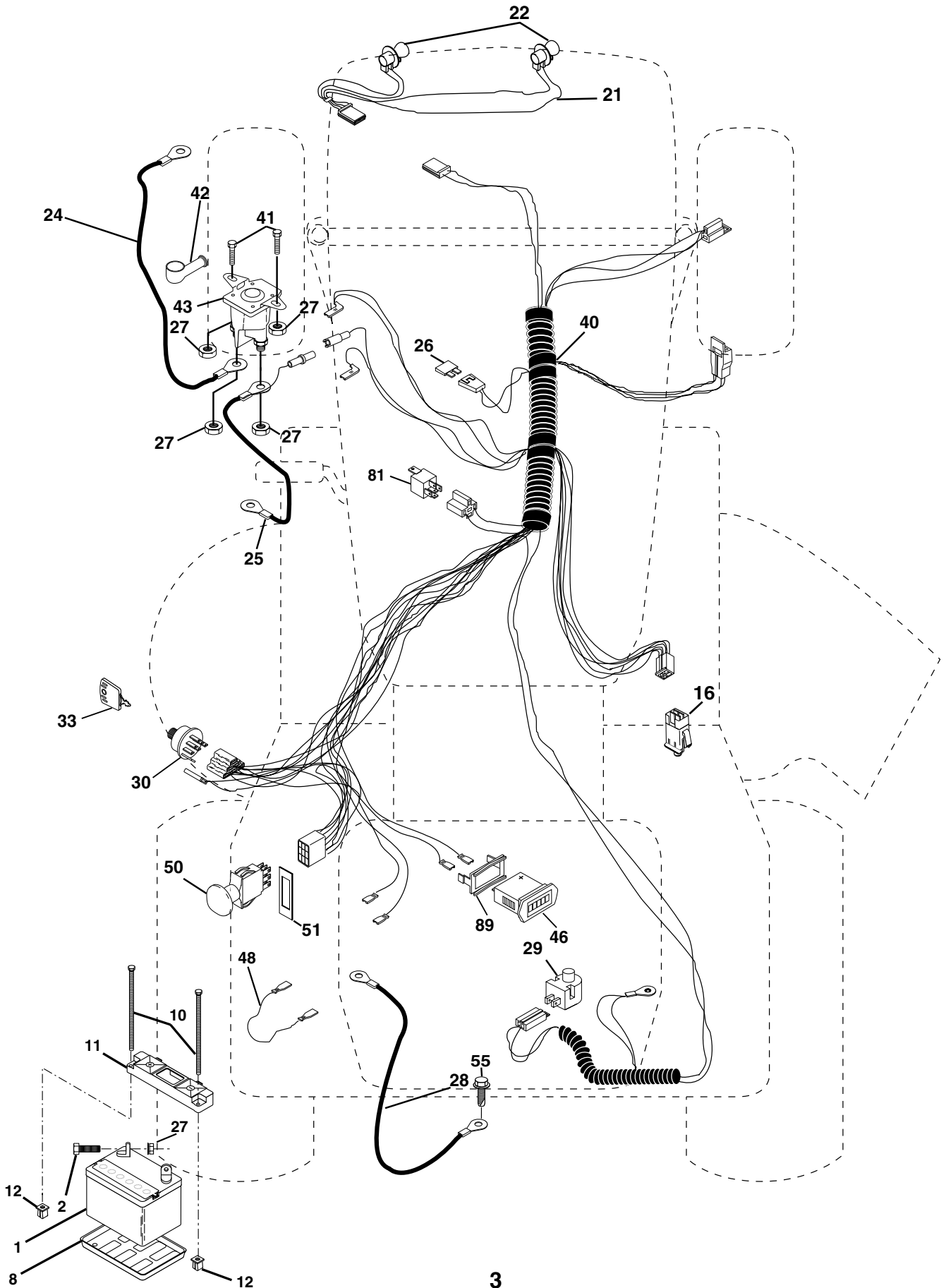

# REPAIR PARTS

TRACTOR - MODEL NO. YTH210 XP(HEYTH210KA), PRODUCT NO. 954 17 00-75  
ELECTRICAL

KEY NO.	PART NO.	DESCRIPTION
1	532 14 49-27	Battery
2	874 76 04-12	Bolt Hex Hd 1/4-20unc X 3/4
8	532 12 48-86	Tray Battery 7.80 x 5.25 Blk
10	532 14 52-11	Bolt Btr Frt 1/4-20 x 7.5 Zinc
11	532 15 01-09	Holddown Battery Front Mount
12	532 14 57-69	Nut Push Nylon 1/4" Battery Frt
16	532 17 61-38	Switch Interlock
21	532 17 56-88	Harness Asm Light W/4152J
22	532 00 41-52	Bulb Light #1156
24	532 12 47-80	Cable Battery 6 Ga 11"red
25	532 14 61-48	Cable Battery 6 Ga W/16 Ga Wire 22"
26	532 17 51-58	Fuse 20 AMP
27	873 51 04-00	Nut Keps hex 1/4-20 Unc
28	532 14 54-91	Cable Ground 6 Ga 21" Black
29	532 16 07-84	Switch Plunger Normal Op Olive
30	532 17 55-66	Switch Ignition
33	532 14 04-01	Key Ign Molded Generic
40	532 17 97-24	Harness Ign.
41	871 11 04-08	Bolt Hex Hd. Fin 1/4-20 x 1/2 Gr. 5
42	532 13 15-63	Cover Terminal Red
43	532 17 88-61	Solenoid
46	532 16 96-35	Hourmeter Snap-In
48	532 14 08-44	Adapter Ammeter Rectangular
50	532 17 46-51	Switch PTO
51	532 14 04-05	Ring Retainer PTO
55	817 49 05-08	Screw Thdrol 5/16-18 x 1/2
81	532 10 97-48	Relay Asm.
89	532 16 96-39	Bracket Snap-In Hourmeter

**NOTE:** All component dimensions given in U.S. inches  
1 inch = 25.4 mm.

# REPAIR PARTS

TRACTOR - MODEL NO. YTH210 XP(HEYTH210KA), PRODUCT NO. 954 17 00-75  
ENCLOSURES

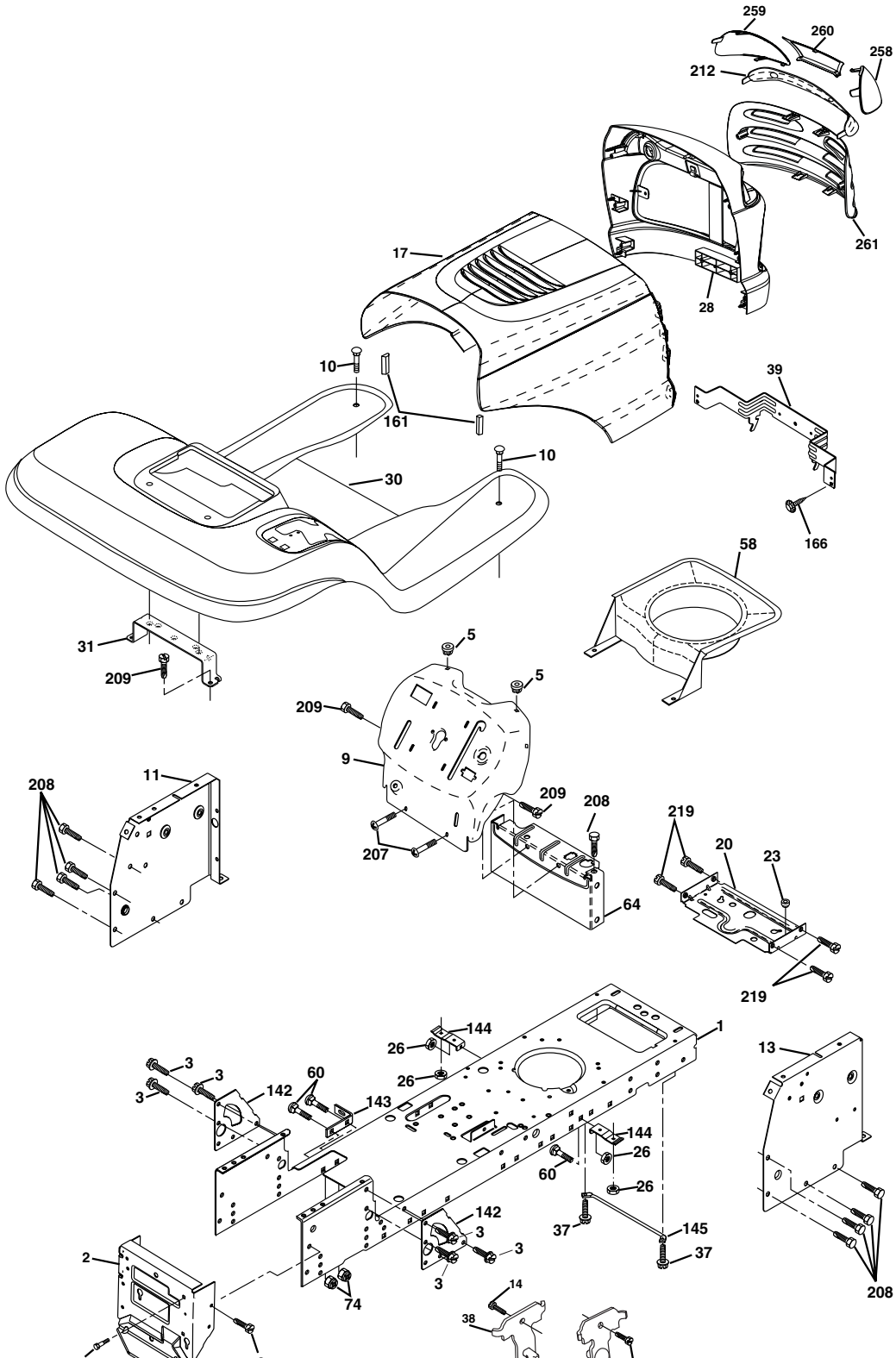

# REPAIR PARTS

TRACTOR - MODEL NO. YTH210 XP(HEYTH210KA), PRODUCT NO. 954 17 00-75  
ENCLOSURES

KEY NO.	PART NO.	DESCRIPTION
1	532 17 46-19	Chassis Stl Stamping
2	532 17 65-54	Drawbar
3	817 06 06-12	Screw 3/8-16x3/4
5	532 15 52-72	Bumper Hood/Dash
9	532 17 19-24	Dash P/L
10	872 14 06-08	Bolt Carriage 3/8-16 x 1
11	532 17 49-96	Panel Dash Lh
14	817 49 06-08	Screw Thdrol 3/8-16 x 1/2
13	532 17 21-06	Panel Dash Rh
17	532 18 52-11	Hood LT/PL Husqvarna
20	532 18 06-79	Plate Mtg Battery Fuel Tank Fr
23	532 12 40-28	Bushing
26	873 80 06-00	Nut Lock Hex W/Ins 3/8-16 Unc
28	532 18 35-38	Grille LT/PL Husqvarna
30	532 18 05-07	Fender Footrest STLTL Pnt
31	532 13 99-76	Bracket Support Fender
37	817 49 05-08	Screw Thdrol 6/16-18 x 1/2 TYT
38	532 17 57-10	Bracket Asm. Pivot Mower Rear
39	532 17 47-14	Bracket Pivot Laser
58	532 17 49-30	Duct Intake Air
60	872 14 06-06	Bolt Rdhd Sqnk 3/8-16unc x 3/4
64	532 15 47-98	Dash Lower STLTL
74	873 68 06-00	Nut Crownlock 3/8-16 UNC
142	532 17 57-02	Plate Reinforcement STLTL
143	532 15 49-66	Bracket Swaybar Chassis
144	532 17 55-82	Bracket Footrest STLTL
145	532 15 65-24	Rod Pivot Chassis/Hood
161	532 18 49-21	Bumper Hood
166	532 17 18-75	Screw HWHD Hi-Lo #13-16 x 3/4
206	532 17 01-65	Bolt Shoulder 5/16-18 TT
207	817 67 05-08	Screw Thdrol 5/16-18 x 1/2 TYTT
208	817 67 06-08	Screw Thdrol 3/8-16 x 1/2 TYT BL
212	532 18 35-48	Insert Lens Reflective
219	817 00 05-12	Screw 5/16-18 x 3/4
258	532 18 52-13	Lens Husq. Laser LT Clear RH
259	532 18 52-14	Lens Husq. Laser LT Clear LH
260	532 18 52-16	Cover Lens Husq. Laser LT
261	532 18 52-12	Insert Grille

**NOTE:** All component dimensions given in U. S. inches  
1 inch = 25.4 mm

# REPAIR PARTS

TRACTOR - MODEL NO. YTH210 XP(HEYTH210KA), PRODUCT NO. 954 17 00-75  
DRIVE

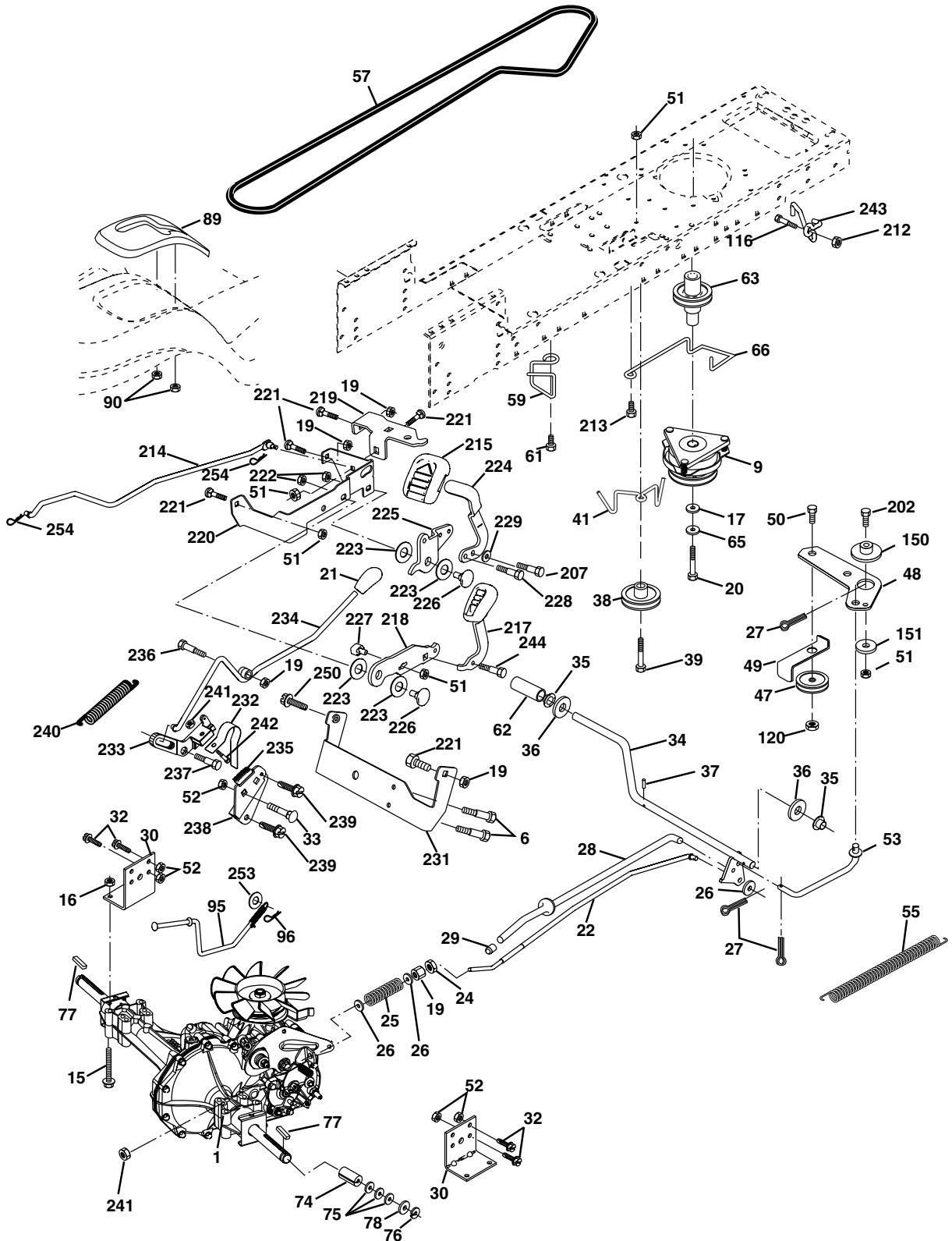

# REPAIR PARTS

## TRACTOR - MODEL NO. YTH210 XP(HEYTH210KA), PRODUCT NO. 954 17 00-75 DRIVE

KEY NO.	PART NO.	DESCRIPTION	KEY NO.	PART NO.	DESCRIPTION
1	-----	Transaxle (Order parts from trans- axle manufacturer) Hydro gear Model 336-0510	89	532 18 14-94	Console, Shift
6	817 06 05-12	Screw 5/16-18	90	532 12 43-46	Nut Self-Thd Wsh-hd 1/4 Zinc
9	532 18 02-20	Clutch	95	532 18 08-25	Rod Bypass
15	874 49 05-44	Bolt Hex Flghd 5/16-18 Gr. 5	96	532 12 47-88	Retainer Spring
16	873 80 05-00	Nut Lock Hex W/Ins. 5/16-18 Unc	116	872 14 06-08	Bolt RDHD SQNK 3/8-16 Unc x 1
17	532 12 61-97	Washer 1-1/2 OD x 15/32 ID x .250	120	873 90 06-00	Nut Lock Flg 3/8-16 Unc
19	873 80 06-00	Nut Lock Hex W/Wsh 3/8-16 Unc	150	532 17 54-56	Spacer Retainer
20	532 17 39-37	Bolt Hex 7/16-20 x 4 x Gr. 5-1.5	151	819 13 32-10	Washer 13/32 x 2 x 10 Ga.
21	532 18 14-54	Knob Custom Control Cruise	202	872 11 06-14	Bolt Carr Sh 3/8-16 x 1-3/4 Gr. 5
22	532 17 58-96	Rod, Brake	207	817 06 05-16	Screw 5/16-18 x 1
24	873 35 06-00	Nut, Hex Jam 3/8-16 Unc	212	532 14 52-12	Nut HexFlange Lock
25	532 10 68-88	Spring, Brake Rod	213	817 06 06-20	Screw 3/8-16 x .75 SMGML TAP/ R.Z
26	819 13 13-16	Washer	214	532 17 47-35	Link Transaxle
27	876 02 04-12	Pin Cotter 1/8 x 3/4 CAD.	215	532 17 56-46	Cover Pedal Forward
28	532 17 57-65	Rod, Parking Brake	217	532 17 94-33	Pedal Reverse
29	532 07 16-73	Cap, Brake, Park	218	532 17 47-13	Arm Control Pedal Reverse
30	532 16 95-92	Bracket, Transaxle	219	532 17 48-39	Bracket Frest Pdl Ctrl. Hyd
32	874 76 05-12	Bolt Hex Hd 5/16-18 Unc x 3/4	220	532 17 47-11	Bracket Mtg. Pedal Control
33	872 14 05-06	Bolt Rdhd Sqnk 5/16-18 Unc x 3/4	221	872 14 06-06	Bolt Rdhd Sqnk 3/8-16 Unc x 3/4
34	532 17 55-78	Shaft, Foot Pedal	222	873 68 07-00	Nut Crownlock 7/16-14 Unc
35	532 12 01-83	Bearing, Nylon	223	532 17 48-40	Washer Nylon 11/16 ID x .060
36	819 21 16-16	Washer	224	532 17 47-36	Pedal Forward
37	532 12 49-63	Pin, Roll	225	532 17 47-12	Arm Control Pedal Forward
38	532 17 91-14	Pulley, Composite	226	532 17 49-02	Bolt Pivot Spacer
39	874 76 06-48	Bolt Fin Hex 3/8-16 Unc x 3	227	532 17 47-10	Cam Reverse Pedal LT
41	532 17 55-56	Keeper, Belt Idler Flat	228	532 17 90-32	Bolt Shoulder 5/16-18
47	532 12 77-83	Pulley, Idler, V-Groove	229	532 17 64-51	Washer Serrated 5/16 x .75
48	532 15 44-07	Bellcrank Clutch Grnd Drw Stil	231	532 17 45-73	Strap Torque
49	532 12 32-05	Retainer, Belt	232	532 17 55-70	Actuator Cruise Disengage
50	872 11 06-12	Bolt Carr. SH 3/8-16 x 1-1/2 Gr. 5	233	532 17 48-56	Pawl Control Cruise
51	873 68 06-00	Nut Crownlock 3/8-16 UNC	234	532 17 48-58	Lever Control Cruise
52	873 68 05-00	Nut, Crownlock 5/16-18 Unc	235	532 17 48-57	Sector Control Cruise
53	532 10 57-10	Link, Clutch	236	532 12 89-03	Bolt Shoulder 3/8-16 Unc 1/44
55	532 10 57-09	Spring, Return, Clutch	237	532 17 01-65	Bolt Shoulder 5/16-18
57	532 14 02-94	V-Belt, Ground Drive	238	532 17 58-07	Arm Mtg. Cruise Sector
59	532 16 96-91	Keeper, Center Span	239	817 49 05-08	Screw Thdrol 5/16 x 1/2
61	817 12 06-14	Screw 3/8-16 x .875	240	532 17 56-10	Spring Return Cruise Control
62	532 12 35-33	Cover, Pedal	241	873 93 04-00	Nut Centerlock 1/4-20 Unc
63	532 17 46-07	Pulley, Engine	242	874 78 04-12	Bolt Fin Hex 1/4-20 Unc x .75
65	810 04 07-00	Washer	243	532 17 82-89	Bracket Anti-Rotation CVX
66	532 15 47-78	Keeper Belt Engine	244	532 16 68-80	Screw 5/16-18 x 5/8
74	532 13 70-57	Spacer, Axle	250	817 06 06-12	Screw 3/8-16 x 3/4
75	532 12 17-49	Washer 25/32 x 1-1/4 x 16 Ga.	253	532 17 94-22	Washer .312 x .615 x 16 Ga.
76	812 00 00-01	E-Ring	254	532 17 80 62	Clip Retainer
77	532 12 35-83	Key, Square			
78	532 12 17-48	Washer 25/32 x 1-5/8 x 16 Ga.			

**NOTE:**All component dimensions give in U.S. inches.  
1 inch = 25.4 mm.



# REPAIR PARTS

TRACTOR - MODEL NO. YTH210 XP(HEYTH210KA), PRODUCT NO. 954 17 00-75  
STEERING ASSEMBLY

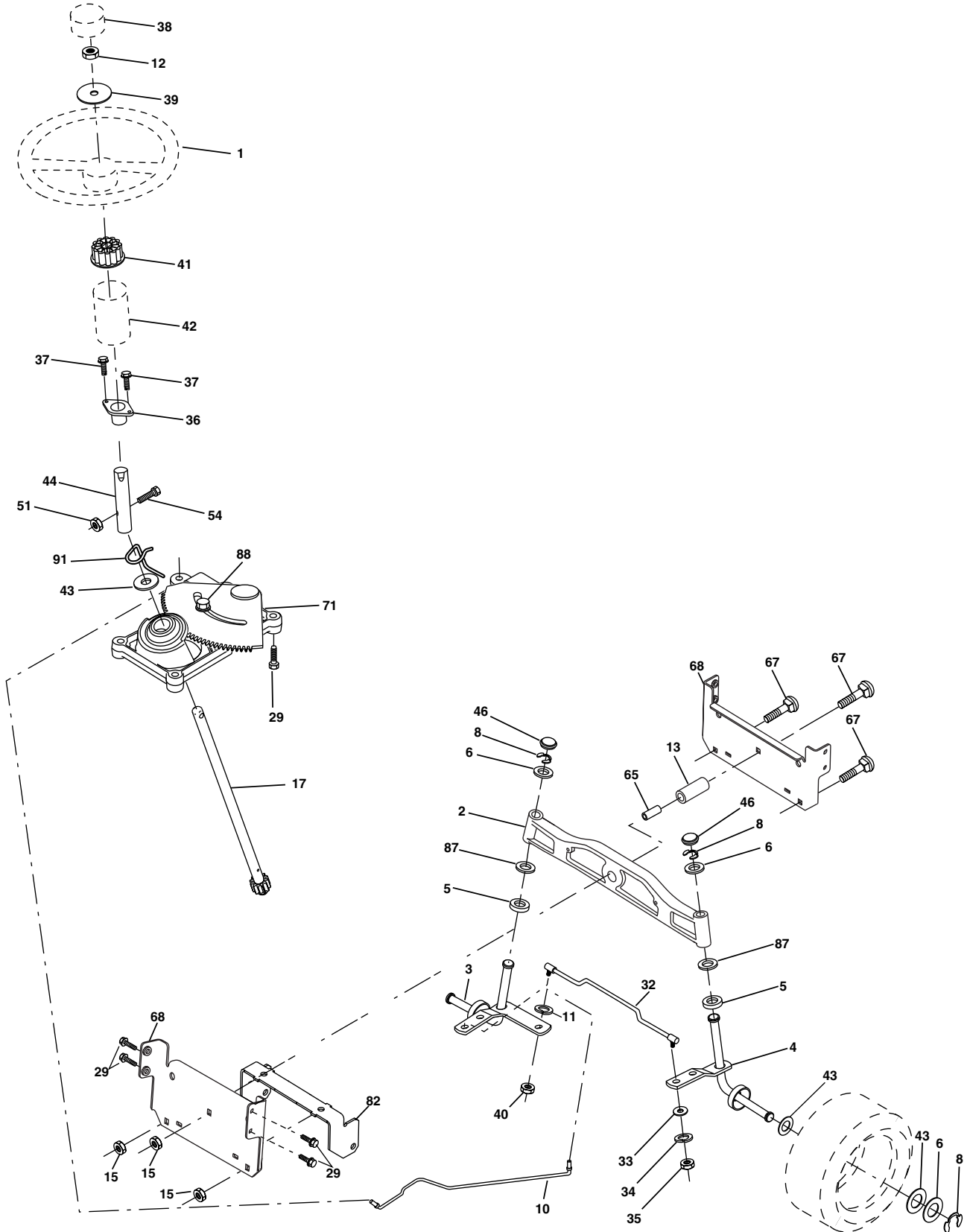

# REPAIR PARTS

TRACTOR - MODEL NO. YTH210 XP(HEYTH210KA), PRODUCT NO. 954 17 00-75  
STEERING ASSEMBLY

KEY NO.	PART NO.	DESCRIPTION
1	532 16 66-27	Wheel Steering
2	532 17 23-93	Axle
3	532 16 98-40	Spindle Asm LH
4	532 16 98-39	Spindle Asm RH
5	532 12 49-31	Bearing Race Thrust Harden
6	532 12 17-48	Washer 25/32 X 1-5/8 X 16 Ga
8	812 00 00-29	Ring Klip #t5304-75
10	532 17 51-21	Link Drag
11	810 04 06-00	Washer Lock Hvy Hlcl Spr 3/8
12	873 94 08-00	Nut Hex Jam Toplock 1/2-20 Unf
13	532 13 65-18	Spacer Brg Axle Front
15	532 14 52-12	Nut Hex Flange Lock
17	532 18 06-41	Shaft Asm Strg
29	817 06 06-12	Screw 3/8-16x3/4
32	532 17 18-88	Rod Tie
33	819 11 12-16	Washer 11/32 x 3/4 x 16 Ga.
34	810 04 05-00	Washer Lock Hry Hlcl Spr 5/16
35	873 54 05-00	Crownlock Nut 5/16 - 24 UNF
36	532 15 50-99	Bushing Strg
37	532 15 29-27	Screw TT #32.5 x 5 x 3/8 Flange
38	532 16 66-26	Cap Wheel Steer
39	819 18 24-11	Washer 9/16 ID x 1-1/2 OD 11 Ga
40	532 12 47-01	Nut Lock Center 3/8-24 Unf
41	532 15 99-45	Adaptor Wheel Strg
42	532 16 96-34	Boot Dash Steering
43	532 12 17-49	Washer 25/32 X 1 1/4 X 16 Ga
44	532 18 06-40	Extension Steering Shaft
46	532 12 12-32	Cap Spindle Fr Top Blk
51	873 54 04-00	Nut Crownlock 1/4-28
54	871 13 04-20	Bolt Hex 1/4-28unf x 1-1/4 Ga. 8
65	532 16 03-67	Spacer Brace Axle
67	872 14 06-18	Bolt Rdhd Sq 3/8-16 x 2-1/4
68	532 16 98-27	Brace, Axle
71	532 17 51-46	Steering Asm
82	532 16 98-35	Bracket Susp Chassis Front
87	532 17 39-66	Washer Flat .781 x 1-1/2 x .14
88	532 17 51-18	Bolt Shoulder 7/16-20
91	532 17 55-53	Clip Steering

**NOTE:** All component dimensions given in U.S. inches  
1 inch = 25.4 mm.

# REPAIR PARTS

## TRACTOR - MODEL NO. YTH210 XP(HEYTH210KA), PRODUCT NO. 954 17 00-75 SEAT ASSEMBLY

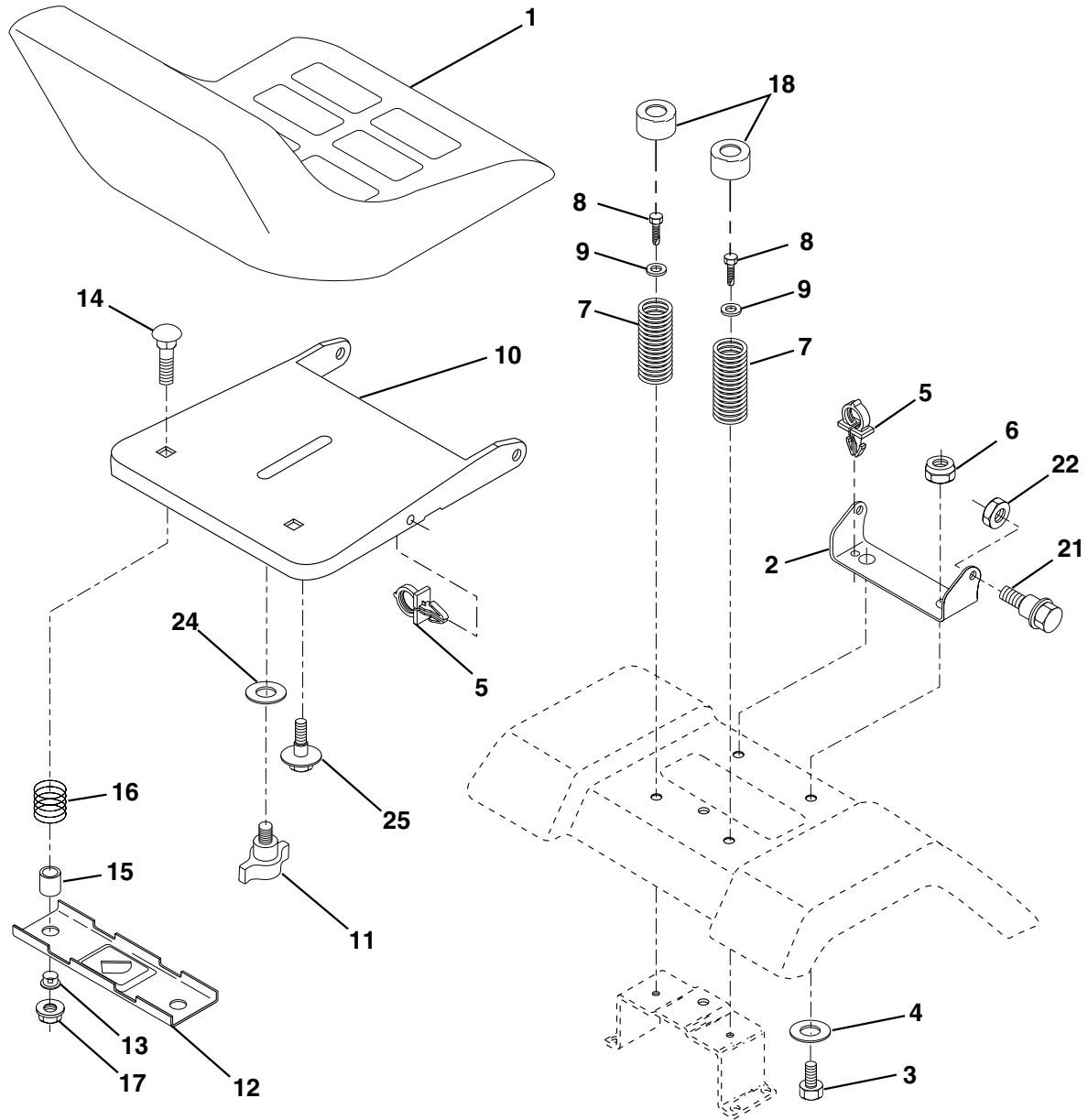

KEY NO.	PART NO.	DESCRIPTION
1	532 18 49-95	Seat
2	532 14 05-51	Bracket Pivot Seat 8 720
3	871 11 06-16	Bolt Hex 3/8-16unc x 1
4	819 13 16-10	Washer 13/32 X 1 X 10 Ga
5	532 14 50-06	Clip Push-In Hinged
6	873 80 06-00	Nut Lock Hex w/Ins. 3/8-16 Unc
7	532 12 41-81	Spring Seat Cprsn 2 250 Blk Zi
8	817 00 06-16	Screw 3/8-16 X 1-1/2
9	819 13 16-14	Washer 13/32 X 1 X 14 Ga
10	532 18 24-93	Pan Seat
11	532 16 63-69	Knob Seat
12	532 12 12-46	Bracket Mounting Switch
13	532 12 12-48	Bushing Snap Blk Nyl 50 Id

KEY NO.	PART NO.	DESCRIPTION
14	872 05 04-12	Bolt Rdhd Sht Nk 1/4-20x1-1/2
15	532 12 12-49	Spacer Split 28x 88 Zinc
16	532 12 37-40	Spring Cprsn 1 310 Blk Pnt
17	532 12 39-76	Nut Lock 1/4 Lge Flg Gr 5 Zinc
18	532 12 42-38	Cap Spring Seat
21	532 17 18-52	Bolt Shoulder 5/16-18 Unc-2A
22	873 80 05-00	Nut Lock Hx w/Ins 5/16-18 Unc PL
24	819 17 19-12	Washer 17/32 X 1-3/16 X 12 Ga
25	532 12 70-18	Bolt Shoulder 5/16-18 X 62

**NOTE:** All component dimensions given in U.S. inches  
1 inch = 25.4 mm.

# REPAIR PARTS

TRACTOR - MODEL NO. YTH210 XP(HEYTH210KA), PRODUCT NO. 954 17 00-75  
DECAL

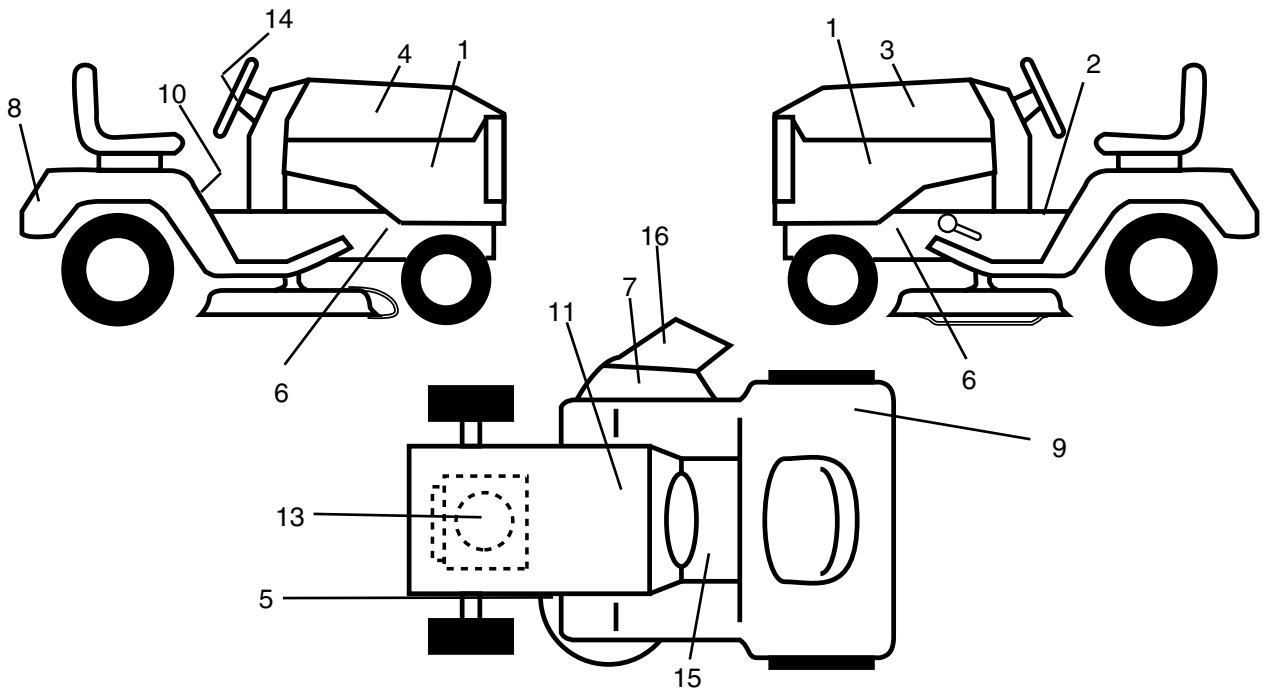

KEY NO.	PART NO.	DESCRIPTION	KEY NO.	PART NO.	DESCRIPTION
1	532 18 51-84	Decal, Pnl Side B&S	15	532 15 97-37	Decal, Brake/Clutch Symbol
2	532 14 08-37	Decal, Brake Parking Sandle	16	532 17 91-28	Decal, Deck "B"
3	532 18 48-90	Decal, Hood, L. H.	--	532 16 25-98	Decal Drawbar Load Limit
4	532 18 48-89	Decal, Hood, R.H.	--	532 16 92-10	Decal By Pass Lt Hydro
5	532 16 03-96	Decal, V-Belt Sch.	--	532 13 83-11	Decal, Handle Lift Height Adjust. (Lift Handle)
6	532 15 97-36	Decal, Chassis Hot Muffler	--	532 18 14-95	Pad, Footrest LH
7	532 18 21-66	Decal, Mower Cutfingher Symbol	--	532 18 14-96	Pad, Footrest RH
8	532 15 06-17	Decal, Logo, Fender	--	532 18 41-20	Manual, Operator's (Euro)
9	532 18 04-32	Decal, Fender 100 DB/CE	--	532 18 41-21	Manual, Operators, (Scan)
10	532 14 54-98	Decal, Read Owners Manual	Available accessories not included with tractor:		
11	532 14 50-05	Decal, Bat Dan/Poi P/L Sym	--	C42	42" Bagger
13	532 18 53-92	Decal, Engine	--	MK420	Kit Mulcher w/Blades
14	532 17 05-64	Decal, Wheel Steering			

## WHEELS & TIRES

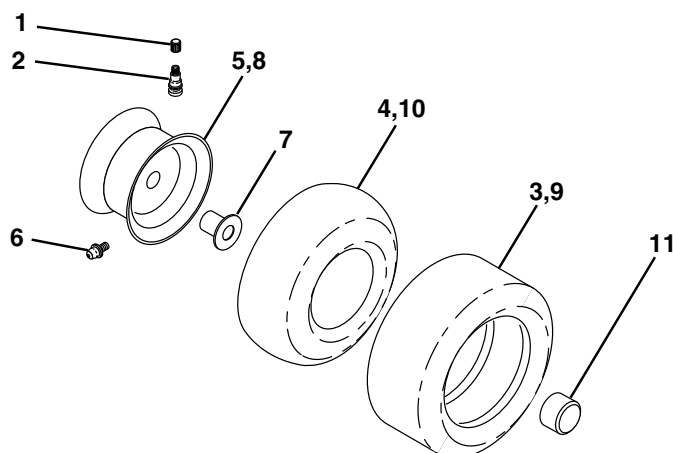

KEY NO.	PART NO.	DESCRIPTION
1	532 05 91-92	Cap Valve Tire
2	532 06 51-39	Stem Valve
3	532 10 62-22	Tire F Ts 15 X 6 0 - 6 Service
4	532 05 99-04	Tube Front (Service Item Only)
5	532 13 83-36	Rim Asm 6"front Silver Service
6	532 12 49-57	Fitting Grease (Front Wheel Only)
7	532 12 49-59	Bearing Flange (Front Wheel Only)
8	532 13 83-37	Rim Asm 8"rear Silver Service
9	532 12 20-82	Tire R Ts 20x10-8 C Service
10	532 12 49-26	Tube Rear (Service Item Only)
11	532 17 50-39	Cap Axle Blk 1 50 X 1 00
--	532 14 43-34	Sealant, Tire (10 oz. tube)

**NOTE:** All component dimensions given in U.S. inches  
1 inch = 25.4 mm

# REPAIR PARTS

TRACTOR - MODEL NO. YTH210 XP(HEYTH210KA), PRODUCT NO. 954 17 00-75  
ENGINE

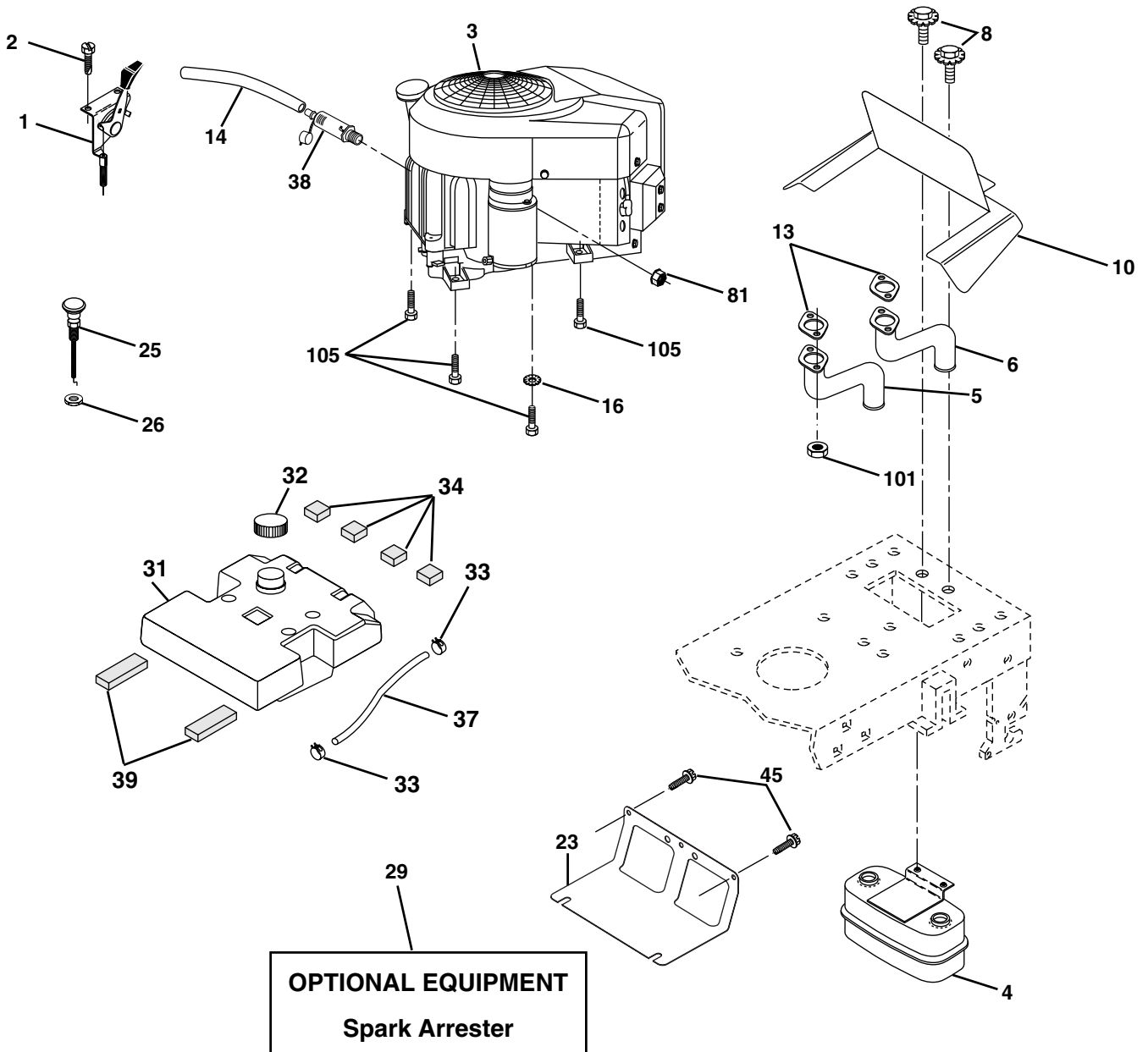

# REPAIR PARTS

**TRACTOR - MODEL NO. YTH210 XP(HEYTH210KA), PRODUCT NO. 954 17 00-75  
ENGINE**

KEY NO.	PART NO.	DESCRIPTION
1	532 17 08-03	Control, Throttle
2	817 72 04-08	Screw, Hex Head, Thread Cutting 1/4-20 x 1/2
3	-----	Engine, KAWASAKI Model Number FH641-ASZO (Order Parts From Engine Manufacturer)
4	532 14 97-23	Muffler
5	532 18 45-79	Tube, Manifold, LH
6	532 18 45-80	Tube, Manifold, RH
8	532 17 18-77	Bolt 5/16-18 UNC x 3/4 w/Sems
10	532 14 66-29	Shield, Heat Muffler CV-Intek
13	532 17 81-51	Muffler Gasket
14	532 14 84-56	Tube Drain Oil Easy
16	811 05 06-00	Washer, Lock, External Tooth 3/8
23	532 16 98-37	Shield, Browning / Debris Guard
25	532 13 27-82	Choke Control
26	873 92 06-00	Nut, Keps 3/8-24 UNF
29	532 13 71-80	Kit, Spark Arrestor
31	532 15 71-03	Tank Fuel 3 50 Rear
32	532 16 16-96	Cap Fuel Gauge 6-3/4" V COV STL
33	532 12 34-87	Clamp, Hose
34	532 10 60-82	Pad, Spacer
37	532 14 21-58	Line, Fuel
38	-----	Plug Drain Oil Easy (Order Parts From Engine Manufacturer)
39	532 10 92-27	Pad, Idler
45	817 00 06-12	Screw Hexwash Thdr
81	873 51 04-00	Nut, Keps Hex 1/4-20 UNC
101	532 16 33-05	Nut Flange M8-1.25 NON-LK ZINK
105	817 12 06-16	Screw 3/8-16 x 1 SMGML TAP/R

**NOTE:** All component dimensions given in U.S. inches  
1 inch = 25.4 mm

# REPAIR PARTS

TRACTOR - MODEL NO. YTH210 XP(HEYTH210KA), PRODUCT NO. 954 17 00-75  
MOWER DECK

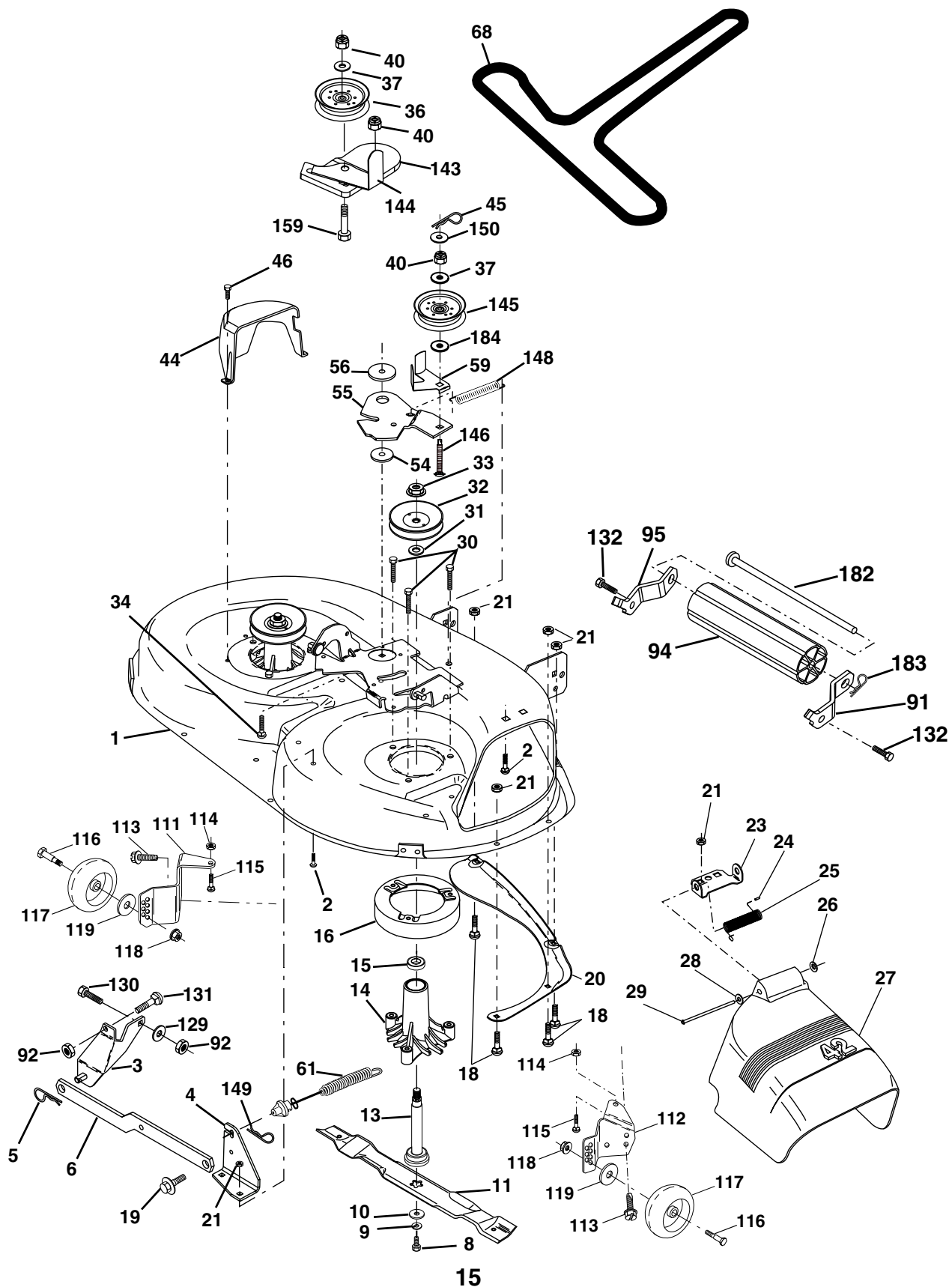

# REPAIR PARTS

## TRACTOR - MODEL NO. YTH210 XP(HEYTH210KA), PRODUCT NO. 954 17 00-75 MOWER DECK

KEY NO.	PART NO.	DESCRIPTION	KEY NO.	PART NO.	DESCRIPTION
1	532 16 58-92	Housing Asm Mower 42"94 T-Path	56	532 16 57-23	Spacer Retainer Mower
2	872 14 05-06	Bolt Rdhd Sqnk 5/16-18unc X3/4	59	532 14 10-43	Guard, Belt
3	532 13 80-17	Bracket Asm Fr Sway Bar 38/42	61	532 17 48-82	Spring Ext. Elect
4	532 16 54-60	Bracket Asm Deck 42"sway Bar	68	532 18 02-60	V-Belt Mower
5	532 12 46-70	Retainer Spring	91	532 18 05-32	Bracket Asm Noseroller LH
6	532 17 80-24	Bar Sway Deck	92	873 80 06-00	Nut Lock Hex w/Ins. 3/8-16 Unc
8	532 85 08-57	Bolt 3/8-24x1 25 Gr8 Patched	94	532 13 22-64	Roller Nose 38 & 42
9	810 03 06-00	Washer Lock Hvy 3/8 Unplated	95	532 18 05-33	Bracket Asm Noseroller RH
10	532 14 02-96	Washer Hard Blade Mower Vented	111	532 17 92-92	Bracket Gauge Wheel Lh
11	532 13 84-98	Blade Mower High Lift"	112	532 17 92-93	Bracket Gauge Wheel Rh
13	532 13 76-45	Shaft Asm W/lower Bearing	113	817 06 05-10	Screw 3/8-16 x .625
14	532 12 87-74	Housing Mandrel Vented(machd)	114	873 51 05-00	Nut Keps 5/16-18 UNC
15	532 11 04-85	Bearing Ball Mandrel	115	872 11 05-05	Bolt Carriage 5/16-18unc x 5/8
16	532 17 44-93	Stripper Round Mower	116	532 12 48-42	Bolt Shoulder
18	872 14 05-05	Bolt Carr 5/16-18 X 5/8	117	532 16 57-46	Wheel Gauge
19	532 13 28-27	Bolt Shoulder	118	873 93 06-00	Nut Centerlock 3/8-16 UNC
20	532 15 97-70	Baffle Vortex 42	119	819 12 14-14	Washer 3/8 x 7/8 x 14 Ga.
21	873 68 05-00	Nut Crown Lock 5/16-18	129	819 13 13-12	Washer 13/32 x 13/16 x 12 Ga.
23	532 17 75-63	Bracket Deflector Mower 42"	130	874 78 06-16	Bolt Fin Hex 3/8-16 UNC x 1 Gr. 5
24	532 10 53-04	Cap Sleeve 80x 112 Blk Mower	131	872 14 06-08	Bolt Rdhd Sqnk 3/8-16 UNC x1
25	532 12 37-13	Spring Torsion Deflector 2 52	132	817 00-06-12	Screw 3/8-16 x .75
26	532 11 04-52	Nut Push Phos & Oil	143	532 15 71-09	Bracket Arm Idler
27	532 17 18-59	Shield Deflector	144	532 15 86-34	Keeper Belt
28	819 11 10-16	Washer 11/32 X 5/8 X 16 Ga	145	532 16 58-88	Pulley Idler Flat
29	532 13 14-91	Rod Hinge 42"6 75 Wlg	146	532 17 19-77	Bolt Carriage Idler
30	532 17 39-84	Screw Thd Rolling	148	532 16 90-22	Spring Return Idler
31	532 12 99-63	Washer Spacer Mower Vented	149	532 16 58-98	Retainer Spring Yellow
32	532 15 35-35	Pulley Mandrel	150	819 09 12-16	Washer 9/32 x 3/4 x 16
33	532 17 83-42	Nut 9/16top Lock Flng	159	872 14 06-14	Bolt RDHD Sqn 3/8-16 x 1-3/4
34	872 11 06-14	Bolt RDHD 3/8-16 x 1-3/4	182	532 17 91-26	Rod Roller Nose
36	532 13 14-94	Pulley Idler Flat 3 060	183	532 16 35-52	Retainer Spring
37	819 13 13-16	Washer 13/32 X 13/16 X 16 Ga	184	819 13 14-10	Washer 13/32 x 7/8 x 10 Ga.
40	873 68 06-00	Nut Lock 3/8-16 Unc	--	532 18 19-62	Replacement Mower, Complete
44	532 14 00-88	Guard Mandrel LH Black	--	532 13 07-94	Mandrel Assembly (Includes Hous- ing, Shaft and Shaft Hardware Only-Pulley Not Included)
45	532 12 47-88	Retainer Spring			
46	532 13 77-29	Screw Thdrol 1/4-20x5/8			
54	532 17 85-15	Washer Hardened			
55	532 15 50-46	Arm Idler 42"mower LT/YT			

**NOTE:** All component dimensions given in U.S. inches  
1 inch = 25.4 mm



# REPAIR PARTS

TRACTOR - MODEL NO. YTH210 XP(HEYTH210KA), PRODUCT NO. 954 17 00-75  
MOWER LIFT

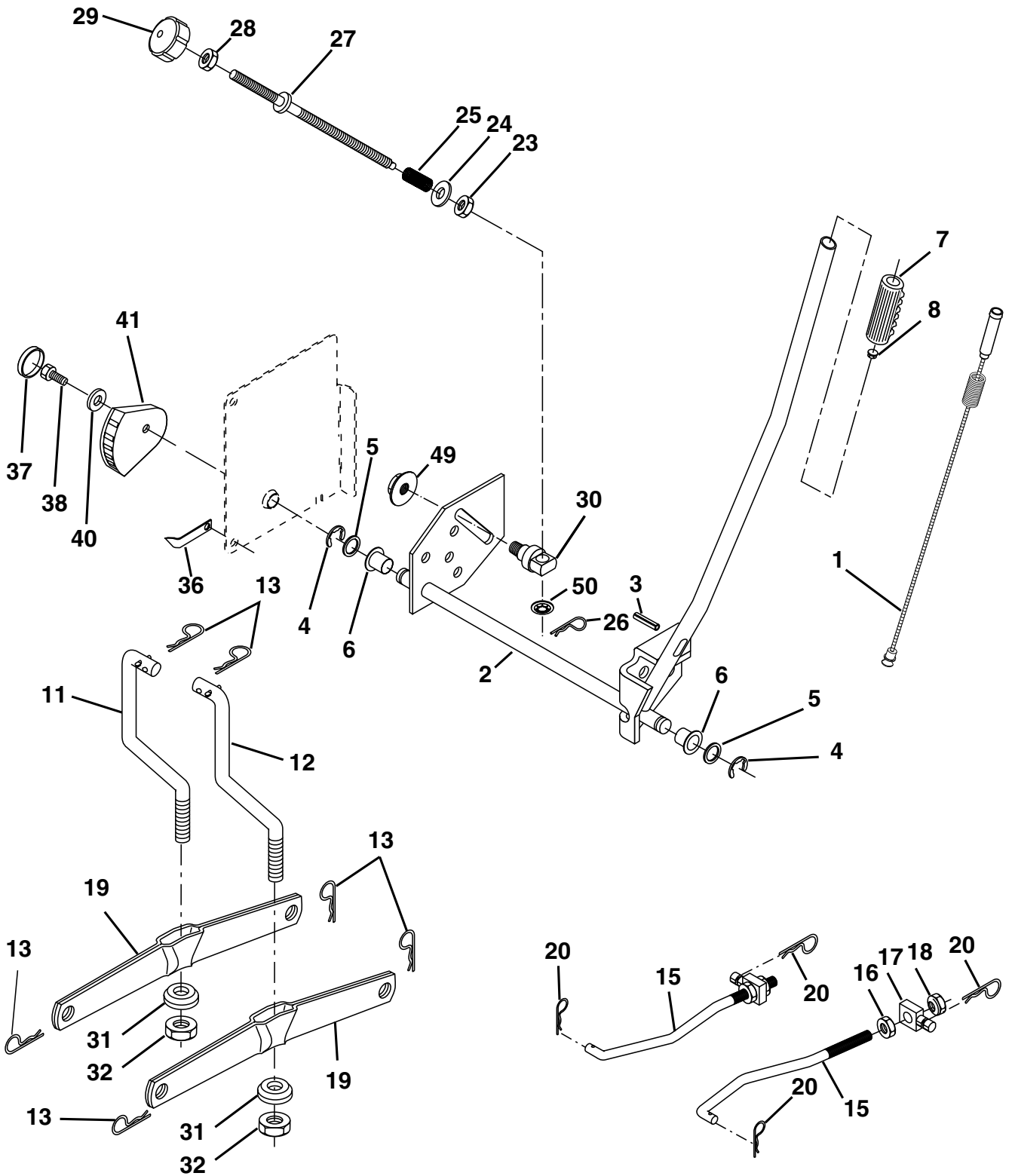

# REPAIR PARTS

TRACTOR - MODEL NO. YTH210 XP(HEYTH210KA), PRODUCT NO. 954 17 00-75  
MOWER LIFT

KEY NO.	PART NO.	DESCRIPTION
1	532 15 94-60	Wire Asm Inner/Sprg w/plngr LT
2	532 15 94-71	Shaft Asm Lift
3	532 10 57-67	Pin Groove
4	812 00 00-02	E Ring #5133-62
5	819 21 16-21	Washer 21/32 X 1 X 21 Ga.
6	532 12 01-83	Bearing Nylon Blk 629 Id
7	532 12 56-31	Grip Handle
8	532 12 45-26	Button Plunger Black
11	532 13 98-65	Link Lift LH Mower
12	532 13 98-66	Link Lift RH Mower
13	532 12 46-70	Retainer Spring
15	532 17 32-88	Link Front
16	873 35 08-00	Nut Jam Hex 1/2-13 Unc
17	532 17 56-89	Trunnion
18	873 80 08-00	Nut Lock w/wsh 1/2-13 Unc
19	532 13 98-68	Arm Suspension Rear
20	532 16 35-52	Retainer Spring
23	532 11 08-07	Nut Special
24	819 13 10-16	Washer 13/32 x 5/8 x 16 Ga.
25	532 12 48-74	Spring 2-1/8"
26	532 16 94-84	Retainer Clip
27	532 12 69-71	Rod Adj Lift
28	873 35 06-00	Nut Hex Jam 3/8-16 UNC
29	532 13 80-57	Knob Inf 3/8-16 UNC
30	532 15 02-33	Trunnion Inf. Height
31	532 16 98-65	Bearing PT Lift
32	873 54 06-00	Nut Crownlock 3/8-24
36	532 15 50-97	Pointer Height Ind
37	532 12 39-35	Plug Hole
38	817 06 05-16	Screw 5/16-18 x 1
40	819 11 24-10	Washer 11/32 x 1-1/2 x 10 Ga.
41	532 15 50-98	Ind Height STLT
49	532 14 52-12	Nut, Hex Flange Lock
50	532 11 04-52	Nut, Push

**NOTE:** All component dimensions given in U.S. inches  
1 inch = 25.4 mm