

CTH150 XP

Spare parts

Ersatzteile

Pièces détachées

Reserve onderdelen

Repuestos

Reservdelar

TRACTOR- -MODEL NO. CTH150XP (HECTH150KA), PRODUCT NO. 954 17 00-76 SCHEMATIC

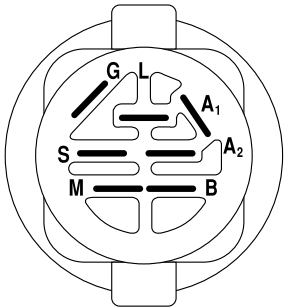
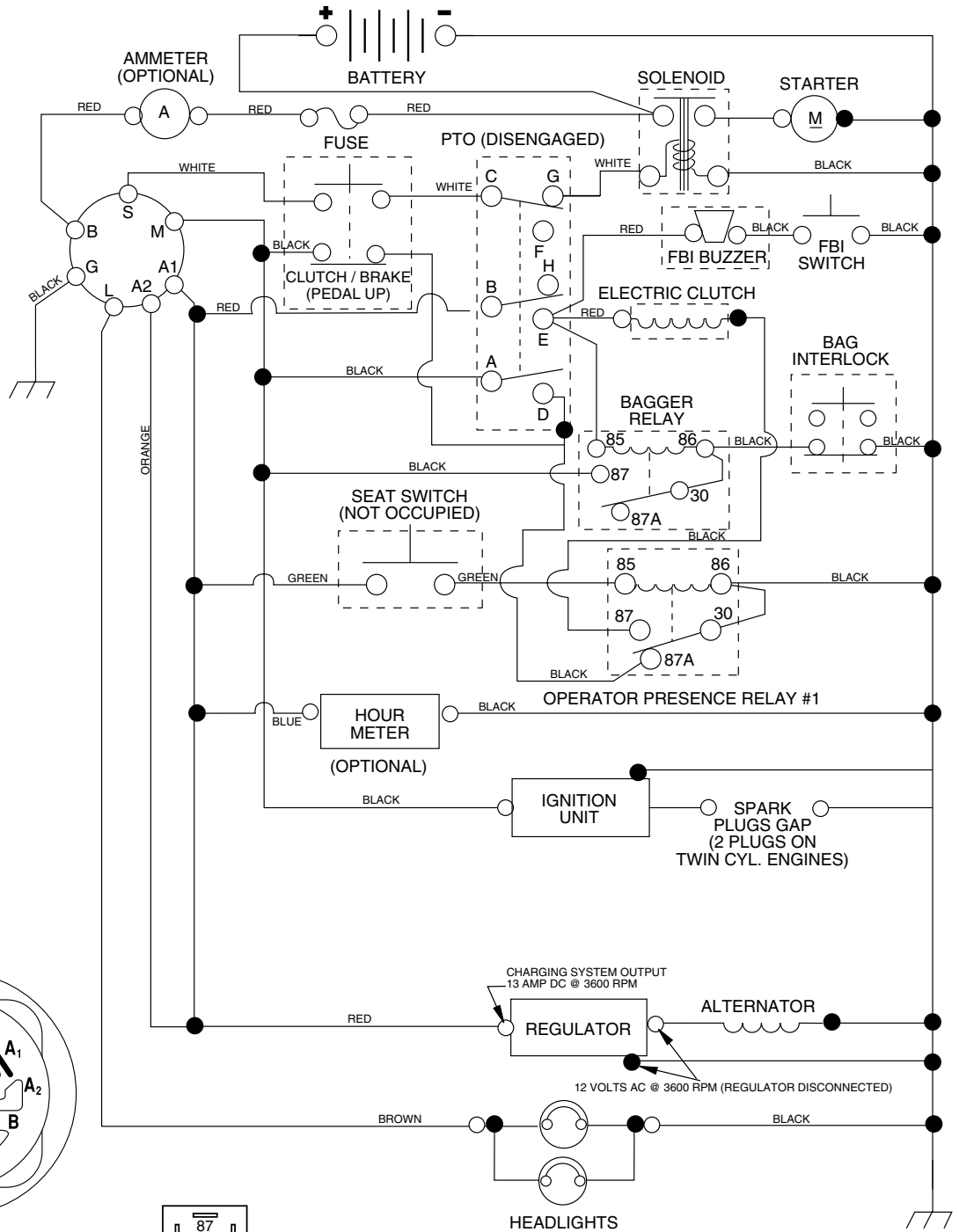

IGNITION SWITCH

POSITION	CIRCUIT	"MAKE"
OFF	M+G+A1	NONE
RUN/LIGHT	B+A1	A2+L
RUN	B+A1	NONE
START	B + S + A1	NONE

WIRING INSULATED CLIPS
NOTE: IF WIRING INSULATED CLIPS WERE REMOVED FOR SERVICING OF UNIT, THEY SHOULD BE REPLACED TO PROPERLY SECURE YOUR WIRING.



RELAY

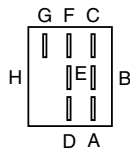

PTO SWITCH

POSITION	CIRCUIT
OFF	C + G, B + H
ON	C + F, B + E, A + D

● NON-REMOVABLE CONNECTIONS

○ REMOVABLE CONNECTIONS

REPAIR PARTS

TRACTOR- -MODEL NO. CTH150XP (HECTH150KA), PRODUCT NO. 954 17 00-76
ELECTRICAL

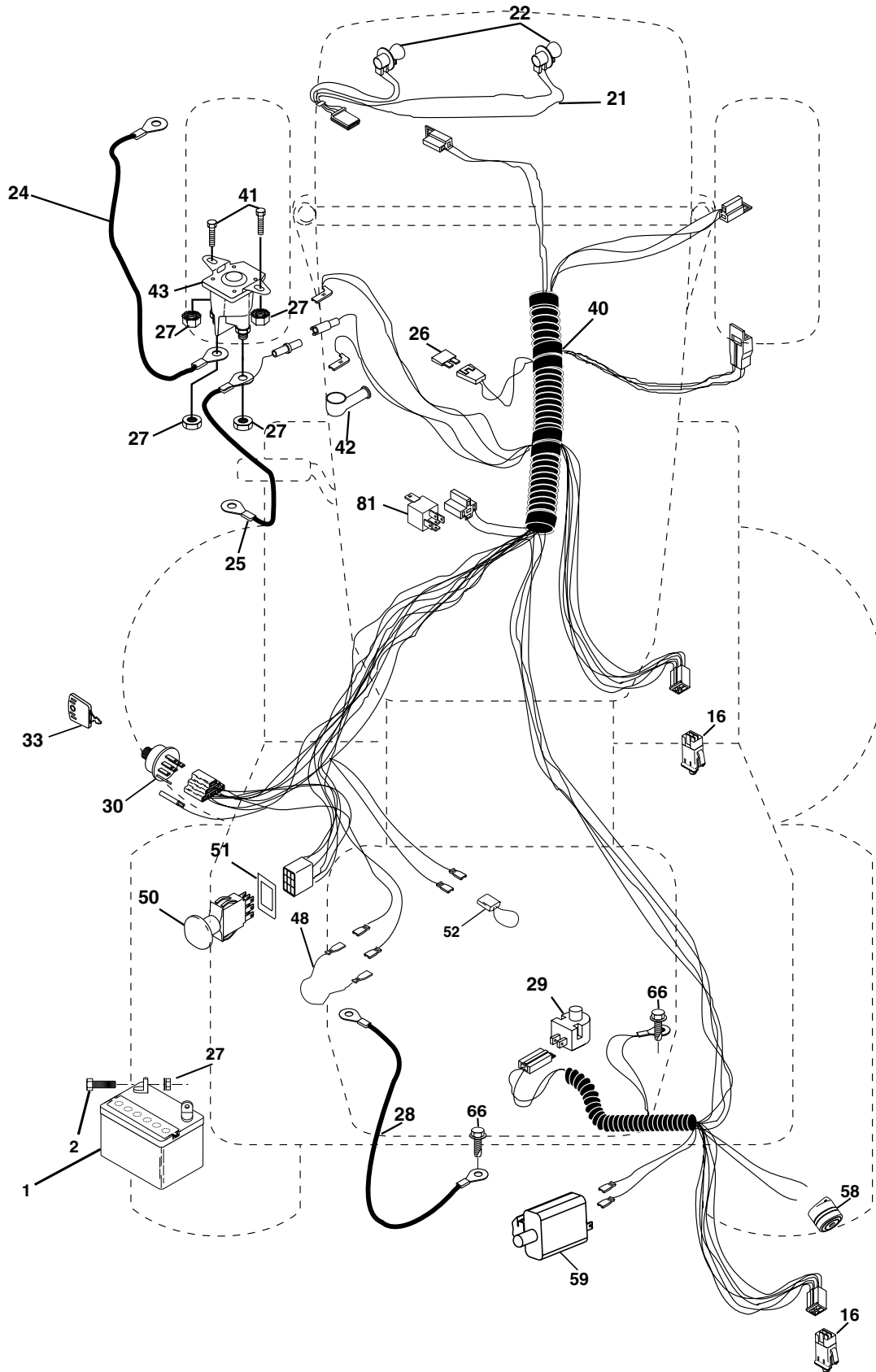

REPAIR PARTS

TRACTOR- -MODEL NO. CTH150XP (HECTH150KA), PRODUCT NO. 954 17 00-76
ELECTRICAL

KEY NO.	PART NO.	DESCRIPTION
1	532 14 49-27	Battery
2	874 76 04-12	Bolt Hex Hd 1/4-20 Unc X 3/4
16	532 17 61-38	Switch Interlock
21	532 17 56-88	Harness Asm Light W/4152J
22	532 00 41-52	Bulb Light
24	532 12 47-80	Cable Starter 6Ga 11" Red
25	532 16 59-87	Cable Battery Crd 56" Red
26	532 17 51-58	Fuse
27	873 51 04-00	Nut Keps Hex 1/4-20 Unc
28	532 12 77-25	Cable Ground 6Ga 18" Black
29	532 16 07-84	Switch Plunger Normal Op Olive
30	532 17 55-66	Switch Ignition
33	532 14 04-01	Key Ign
40	532 17 97-27	Harness Ign
41	871 11 04-08	Bolt Flk Fin Hex 1/4-20 Unc X 1/2
42	532 13 15-63	Cover Terminal Red
43	532 17 88-61	Solenoid
48	532 14 08-44	Adapter Ammeter Rectangular
50	532 17 46-51	Switch PTO
51	532 14 04-05	Ring Retainer PTO
52	532 14 19-40	Protection Wire Loop
58	532 16 94-19	Buzzer Crd
59	532 18 03-79	Switch FBI CRD
66	817 49 06-08	Screw Thdrol 3/8-16 x 1/2 Ty-Tt
81	532 10 97-48	Relay Asm

NOTE: All component dimensions given in U.S. inches.
1 inch = 25.4 mm.

REPAIR PARTS

TRACTOR- -MODEL NO. CTH150XP (HECTH150KA), PRODUCT NO. 954 17 00-76
CHASSIS AND ENCLOSURES

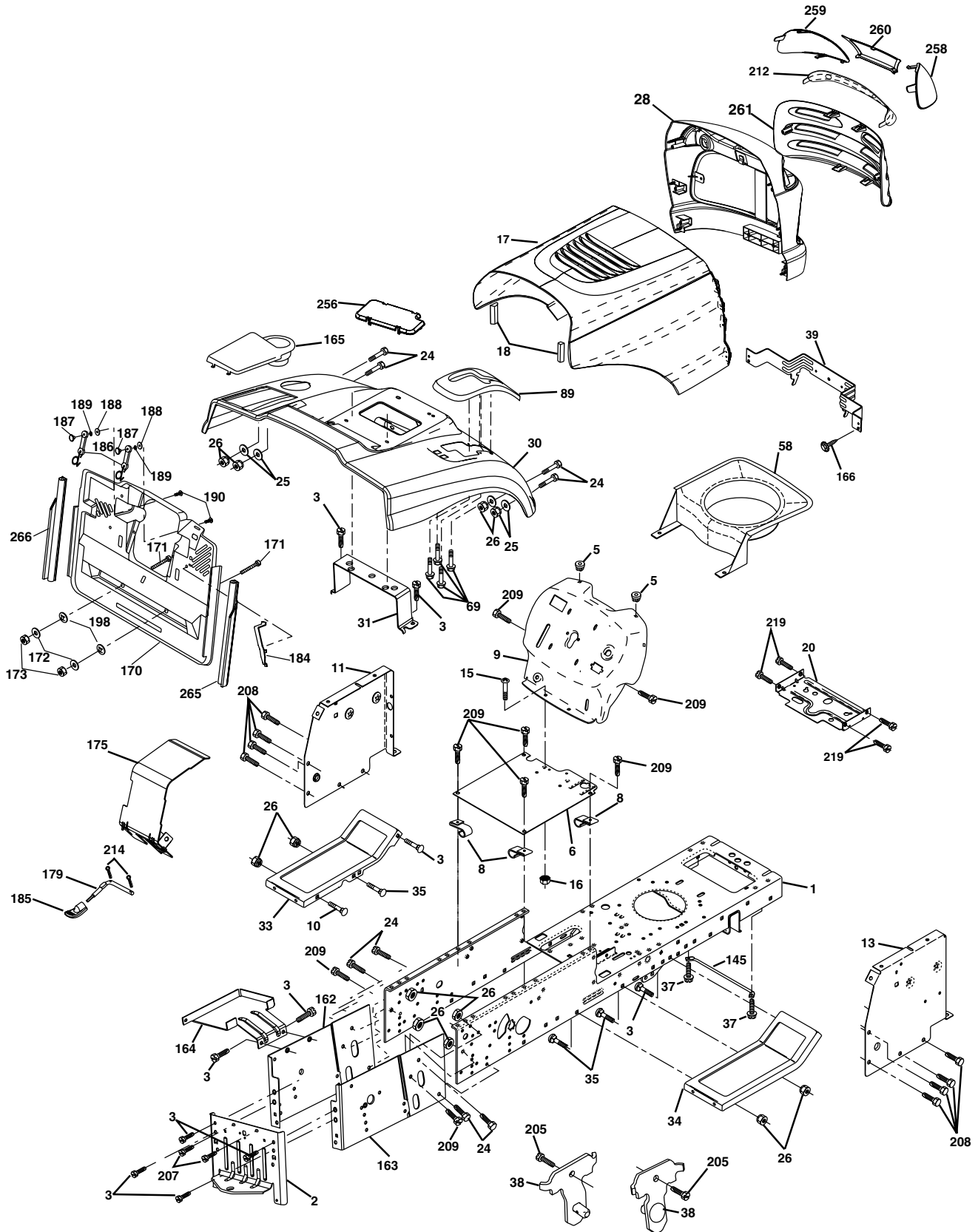

REPAIR PARTS

TRACTOR- -MODEL NO. CTH150XP (HECTH150KA), PRODUCT NO. 954 17 00-76 CHASSIS AND ENCLOSURES

KEY NO.	PART NO.	DESCRIPTION	KEY NO.	PART NO.	DESCRIPTION
1	532 17 46-20	Chassis	164	532 16 56-05	Support Battery CRD
2	532 18 03-84	Drawbar	165	532 18 11-00	Cover Battery
3	817 06 06-12	Screw 3/8-16 x 3/4	166	532 17 18-75	Screw HwHd Hi-Lo #13-16 x 3/4
5	532 15 52-72	Bumper Hood/Dash	170	532 17 88-62	Backplate Asm CRD
6	532 18 44-19	Saddle	171	872 14 06-20	Bolt Rdhd Sqnk 3/8-16 x 2-1/2 Gr. 5
8	532 12 64-71	Clip Insulator 13/32 Mtg. Hole	172	819 13 20-16	Washer 13/32 x 1-1/4 x 16 Ga.
9	532 18 52-09	Dash	173	873 51 06-00	Nut, Keps Hex 3/8-16 UNC
10	872 14 06-08	Bolt, Carriage 3/8-16 x 3/4	175	532 18 03-10	Guard Trap
11	532 17 49-96	Panel, Dash, L.H.	179	532 18 03-76	Rod Pivot FBI CRD
13	532 17 21-06	Panel, Asm. Dash R.H.	184	532 17 46-62	Bracket Actuator Bagger CRD
15	874 18 05-12	Screw, Machine, Truss Head 5/16-18 UNC x 3/4	185	532 18 11-01	Knob Rod Brake Parking
16	873 51 05-00	Nut	186	532 16 07-93	Latch Asm Mulch/Bagger
17	532 18 52-11	Hood	187	532 12 50-04	Nut Weld
18	532 18 49-21	Bumper Hood Large	188	819 06 12-16	Washer #10
20	532 18 06-79	Plate Mtg Battery/Tank Fuel Fr.	189	810 07 10-00	Washer Lock #10
24	874 78 06-16	Bolt	190	871 08 10-10	Screw Pan Hd Phillip 10-24 x 5/8
25	819 13 13-12	Washer 13/32 x 13/16 x 12 Gauge	198	532 16 89-37	Nut, Push
26	873 80 06-00	Nut	205	817 49 06-08	Screw Thdrol 3/8-16 x 1/2
28	532 18 35-38	Grille /Lens Asm	207	817 67 05-08	Screw Thdrol 5/16-18 x 1/2
30	532 17 96-45	Fender	208	817 67 06-08	Screw Thdrol 3/8-16 x 1/2
31	532 16 51-56	Bracket, Fender Support	209	817 00 06-12	Screw Hex Wsh Thdrol 3/8-16
33	532 18 10-57	Footrest, L.H.	212	532 18 35-48	Insert Lens Reflective
34	532 18 10-58	Footrest, R.H.	214	532 12 47-88	Retainer Spring
35	872 11 06-06	Bolt	219	817 00 05-12	Screw 5/16-18 x 3/4
37	817 49 05-08	Screw Thdrol 5/16-18 x 1/2 TYT	256	532 18 13-61	Cover Fender Rack CRD
38	532 18 17-48	Bracket Asm Pivot Mower Rear	258	532 18 52-13	Len Husq. laser LT Clear RH
39	532 17 47-14	Bracket Pivot Laser	259	532 18 52-14	Len Husq. laser LT Clear LH
58	532 17 49-30	Duct Air Engine	260	532 18 52-16	Cover Lens Husq. Laser LT
69	532 14 24-32	Screw Hex Wsh	261	532 18 52-12	Insert Grille
89	532 18 10-99	Console	265	532 18 57-04	Seal RH Side Bagger
145	532 15 65-24	Rod Pivot Chassis/Hood	266	532 18 57-03	Seal LH Side Bagger
162	532 18 03-82	Bracket Exten Chassis Lh CRD			
163	532 18 03-83	Bracket Exten Chassis Rh CRD			

NOTE: All component dimensions given in U.S. inches.
1 inch = 25.4 mm.

Correction:

Key

58 532 18 44-60

REPAIR PARTS

TRACTOR- -MODEL NO. CTH150XP (HECTH150KA), PRODUCT NO. 954 17 00-76 DRIVE

KEY NO.	PART NO.	DESCRIPTION	KEY NO.	PART NO.	DESCRIPTION
1	-----	Transaxle Hydro Gear 321-0510 (Order parts from transaxle manufacturer)	95	532 17 00-15	Control Asm Bypass Hydro
8	532 16 56-19	Rod, Shift Fender Adjust Lt	96	532 12 47-88	Spring, Retainer 1"
9	532 18 02-20	Clutch Ele	116	872 14 06-08	Bolt RDHD SQNK 3/8-16 x 1
10	876 02 04-16	Pin, Cotter 1/8 x 1	120	873 90 06-00	Nut Lock Flg. 3/8-16 Unc
14	810 04 04-00	Washer, Lock Hvy Helical	145	874 49 05-44	Bolt Hex FGHD 5/16-18 x Gr 5
16	873 80 05-00	Nut, Lock Hex w/Ins 5/16-18 UNC	150	532 16 58-50	Bushing, Bellcrank Grnd Dr
17	532 12 61-97	Washer 1-1/2 OD x 15/32 ID x .250	151	819 13 32-10	Washer 13/32 x 2 x 10 Ga.
20	871 17 07-64	Bolt, Hex 7/16-20 x 4	156	532 16 60-02	Washer Srrted 5/16ID x 1.125
21	532 12 12-74	Knob Duckhead 1/4-13 Unc Blk	158	532 16 55-89	Bracket Shift Mount
22	532 17 56-07	Rod, Brake	159	532 16 54-94	Hub Tapered Flange Shift Lt
24	873 35 06-00	Nut	160	819 29 20-16	Washer 29/32 x 1-1/4 x 16 Ga.
25	532 10 68-88	Spring, Rod, Brake	161	872 14 04-06	Bolt Rdhd Sqnk 1/4-20 x 3/4 Gr 5
26	819 13 13-16	Washer 13/32 x 7/8 x 16 Ga.	162	873 68 04-00	Nut Crownlock 1/4-20 Unc
27	876 02 04-12	Pin, Cotter 1/8 x 3/4	163	874 78 04-16	Bolt Hex Fin 1/4-20 Unc x 1 Gr 5
28	532 17 57-65	Rod, Parking Brake	164	819 09 10-10	Washer 5/8 x .281 x 10 Ga.
29	532 07 16-73	Cap, Parking Brake	165	532 16 56-23	Bracket Pivot Lever
30	532 16 95-92	Bracket, Mfg. Transaxle	166	532 16 68-80	Screw 5/16-18 x 5/8
34	532 17 55-78	Shaft, Asm Pedal Foot CRD	167	532 16 55-88	Bracket Support Shift CRD
35	532 12 01-83	Bearing, Nylon	168	532 16 54-92	Bolt Shoulder 5/16-18 x .561
36	819 21 16-16	Washer 21/32 x 1 x 16 Ga.	169	532 16 55-80	Plate Fastening Lt
37	532 12 49-63	Pin, Roll 3/16 x 1"	171	817 49 06-08	Screw Thdrol 3/8-16 x 1/2 Ty-Tt
38	532 16 59-36	Pulley Flat Composite 3.06"	172	532 17 02-71	Shaft Asm Shifter Frt CRD
39	874 76 06-44	Bolt Fin Hex 3/8-16 Unc x 2-3/4	177	532 16 59-32	Keeper Flat Idler 3.06" CRD
40	532 12 49-65	Spacer, Split 395 x 59 Bzp	178	532 16 59-33	Keeper Belt Idler 1.88" CRD
42	819 13 13-12	Washer 13/32 x 13/16 x 12 Ga.	179	532 12 09-58	Washer Sintered
43	819 11 10-12	Washer 11/32 x 5/8 x 12 Ga	180	532 16 56-30	Pulley, Idler, Flat 1.88"CRD
47	532 12 77-83	Pulley, Idler, V Groove Plasitc	181	532 18 02-11	Bracket Idler Ground Drive CRD
48	532 15 44-07	Bellcrank Clutch Grnd Drv	182	532 18 26-82	Keeper Belt 2.5" Od V-Idler CRD
49	532 12 32-05	Retainer, Belt Style Spring	183	532 17 90-50	Pulley V-Idler 2.50" Od CRD
50	872 11 06-12	Bolt Carr. SH 3/8-16 x 1-1/2 Gr. 5	184	817 49 06-44	Screw Hexwsh Thdrol 3/8-16 x 2-3/4
51	873 68 06-00	Nut, Crownlock 3/8-16 UNC	185	532 17 00-08	Link Shift
52	873 68 05-00	Nut Crownlock 5/16-18	186	532 16 56-14	Hub Tapered Round CRD
53	532 10 57-10	Link, Clutch 7.66	187	817 58 05-20	Screw Thdrol 5/16-18 x 1.25
55	532 10 57-09	Spring, Return, Clutch	197	532 16 96-13	Nyliner Snap-In 5/8
56	817 06 06-20	Screw 3/8-16 x 1-1/4	199	532 16 96-12	Bolt Shoulder 5/16-18 Unc
57	532 17 01-40	V-Belt Kev 112" 0650 CRD	200	872 14 05-08	Bolt RDHD SQNK 5/16-18 x 1
62	532 12 35-33	Cover, Pedal	202	872 11 06-14	Bolt Carr. Sh. 3/8-16 x 1-3/4 Gr. 5
63	532 18 03-97	Pulley, Engine	207	532 16 98-45	Washer Nylon Rear
65	810 04 07-00	Washer	212	532 14 52-12	Nut Hex Flange Lock
66	532 15 47-78	Keeper, Belt Engine F-Proof	214	532 17 56-09	Shaft Asm. Brake
71	532 16 91-83	Strap, Torque, Lh	215	532 17 56-52	Rod Brake Hydro
73	532 16 91-82	Strap, Torque, Rh	243	532 17 82-89	Bracket Anti-Rotation
74	532 13 70-57	Spacer, Split	250	817 06 06-12	Screw 3/8-16 x 3/4
75	532 12 17-49	Washer 25/32 x 1-1/4 x 16 Ga.	255	532 17 56-08	Brace Shaft Brake Mtg.
76	812 00 00-01	Ring, E	258	532 17 80-62	Clip Retainer
77	532 12 35-83	Key, Square	259	532 18 02-12	Bracket Pulley IDL Hydro Grd. Dr.
78	532 12 17-48	Washer 25/32 x 1-5/8 x 16 Ga.	260	532 18 17-81	Bracket Idler Chassis
81	532 17 00-06	Asm, Shaft	261	532 13 14-94	Pulley Idler flat
82	532 16 57-11	Spring, Torsion	263	817 00 06-12	Screw HXWSH THDROL 3/8-16 x 3/4 Blk
83	819 17 12-16	Washer 17/32 x 3/4 x 16 Ga.			
84	532 17 00-07	Link, Transaxle			

NOTE: All component dimensions given in U.S. inches
1 inch = 25.4 mm

REPAIR PARTS

TRACTOR- -MODEL NO. CTH150XP (HECTH150KA), PRODUCT NO. 954 17 00-76
STEERING ASSEMBLY

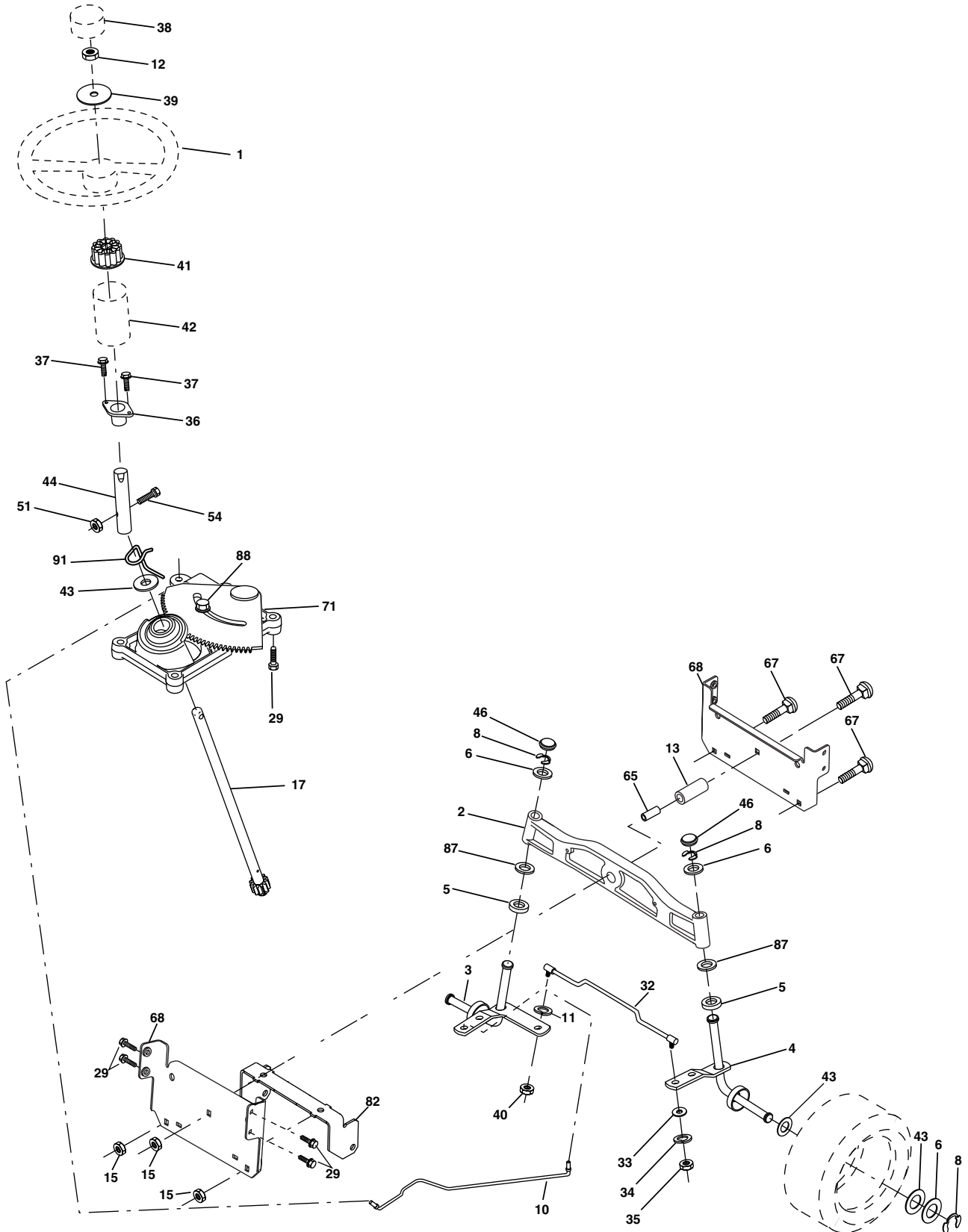

REPAIR PARTS

TRACTOR- -MODEL NO. CTH150XP (HECTH150KA), PRODUCT NO. 954 17 00-76 STEERING ASSEMBLY

KEY NO.	PART NO.	DESCRIPTION
1	532 16 66-27	Steering Wheel
2	532 17 23-93	Front Axle Assembly
3	532 16 98-40	Spindle Assembly, L.H.
4	532 16 98-39	Spindle Assembly, R.H.
5	532 12 49-31	Bearing, Race, Thrust, Hardened
6	532 12 17-48	Washer 25/32 x 1-5/8 x 16 Gauge
8	812 00 00-29	Ring, Klip
10	532 17 51-21	Link, Drag
11	810 04 06-00	Washer, Lock
12	873 94 08-00	Nut Hex Jam Toplock 1/2-20 Unf
13	532 13 65-18	Spacer Axle
15	532 14 52-12	Nut Hex Flange Lock
17	532 18 06-41	Shaft Assembly, Steering
29	817 06 06-12	Screw 3/8-16 x 3/4
32	532 17 18-88	Rod, Tie
33	819 11 12-16	Washer 11/32 x 3/4 x 16 Ga.
34	810 04 05-00	Washer Lock Hvy Hlcl Spr 5/16
35	873 54 05-00	Crownlock Nut 5/16-24 Unf
36	532 15 50-99	Bushing, Steering
37	532 15 29-27	Screw TT #10-32 x 5 x 3/8 Flange
38	532 16 66-26	Cap Wheel Steer
39	819 18 24-11	Washer 9/16 x 1-1/2 11 Ga.
40	532 12 47-01	Nut Lock Center 3/8-24 Unf
41	532 15 99-45	Adaptor, Steering Wheel
42	532 16 96-34	Boot, Steering Dash P/L Mtl
43	532 12 17-49	Washer 25/32 x 1-1/4 x 16 Gauge
44	532 18 06-40	Extension Steering
46	532 12 12-32	Cap, Spindle
51	873 54 04-00	Nut Crownlock 1/4-28
54	871 13 04-20	Bolt Hex 1/4-28 Unf x 1-1/4 Gr. 8
65	532 16 03-67	Spacer Axle
67	872 14 06-18	Bolt Rdhd Sq 3/8-16 x 2-1/4
68	532 16 98-27	Brace Axle
71	532 17 51-46	Steering Asm.
82	532 16 98-35	Bracket Susp. Chassis Front
87	532 17 39-66	Washer Flat .781 x 1-1/2 x .14
88	532 17 51-18	Bolt Shoulder 7/16-20 Unc
91	532 17 55-53	Clip Steering

NOTE: All component dimensions given in U.S. inches.
1 inch = 25.4 mm.

REPAIR PARTS

TRACTOR- -MODEL NO. CTH150XP (HECTH150KA), PRODUCT NO. 954 17 00-76 SEAT ASSEMBLY

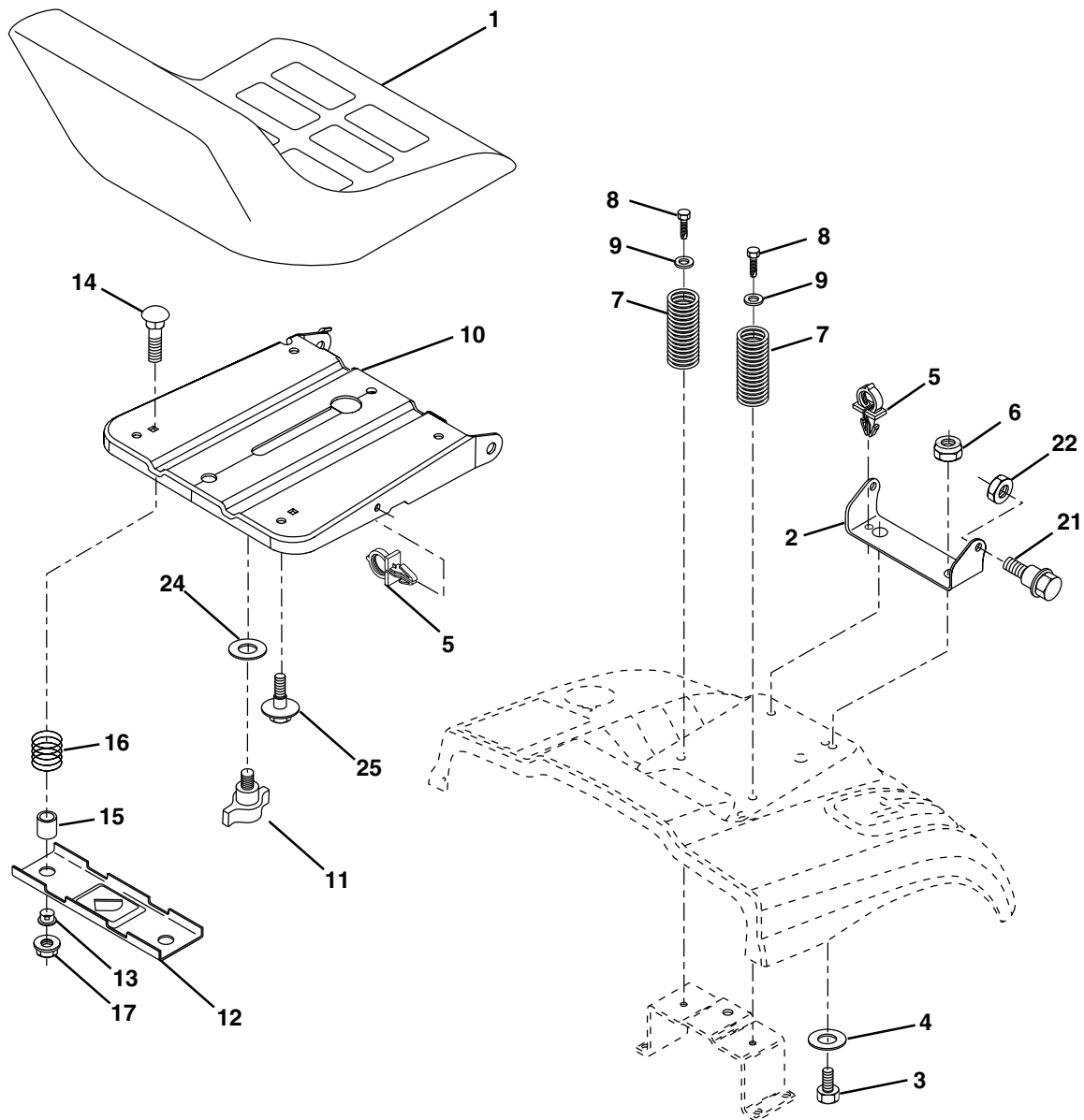

KEY NO.	PART NO.	DESCRIPTION
1	532 18 49-95	Seat
2	532 14 05-51	Bracket Pnt Pivot Seat (blk)
3	871 11 06-16	Bolt Fin Hex 3/8-16 x 1 Blk
4	819 13 16-10	Washer Flat 13/32 x 1 x 10 Ga.
5	532 14 50-06	Clip Push In Hinged
6	873 80 06-00	Nut Lock Hex w/Insert 3/8-16
7	532 12 41-81	Spring Seat Cprsn 2 250 Blk Zi
8	817 00 06-16	Screw 3/8-16 X 1.5
9	819 13 16-14	Washer 13/32 X 1 X 14 Ga
10	532 18 24-93	Pan Pnt Seat
11	532 16 63-69	Knob Seat Adj. Wingnut
12	532 12 12-46	Bracket Pnt Mounting Switch

KEY NO.	PART NO.	DESCRIPTION
13	532 12 12-48	Bushing Snap Blk Nyl 50 Id
14	872 05 04-12	Bolt Rdhd Sht Nk 1/4-20x1-1/2
15	532 12 12-49	Spacer Split
16	532 12 37-40	Spring Cprsn
17	532 12 39-76	Nut Lock 1/4 Lge Flg Gr 5 Zinc
21	532 17 18-52	Bolt Shoulder 5/16-18 Unc-2A
22	873 80 05-00	Nut Hex Lock w/Ins 5/16-18
24	819 17 19-12	Washer 17/32 X 1-3/16 X 12 Ga.
25	532 12 70-18	Bolt Shoulder 5/16-18 X 62

NOTE: All component dimensions given in U.S. inches.
1 inch = 25.4 mm

REPAIR PARTS

TRACTOR- -MODEL NO. CTH150XP (HECTH150KA), PRODUCT NO. 954 17 00-76 DECALS

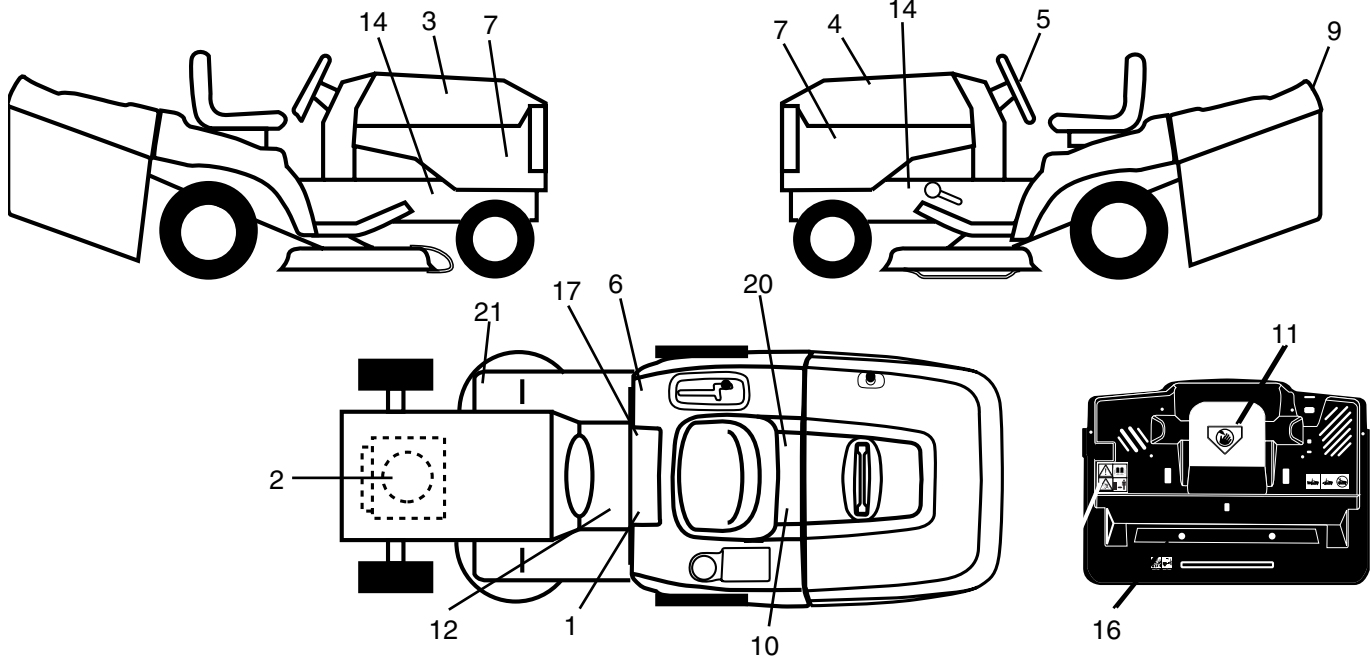

KEY NO.	PART NO.	DESCRIPTION
1	532 14 54-98	Decal Read Owner's Manual Sym
2	532 18 54-35	Decal Hp Engine
3	532 18 48-33	Decal Hood Rh
4	532 18 48-34	Decal Hood Lh
5	532 17 05-64	Decal Wheel Steering
6	532 18 04-32	Decal 100 DBA/CE
7	532 18 51-84	Decal Panel Side B&S Logo
9	532 15 06-17	Decal Fender Logo
10	532 14 50-05	Decal Bat Dan/Poi P/L Sym Wpn
11	532 18 21-66	Decal Mower Cut Finger Symbol
12	532 15 97-37	Decal Brake/Clutch Symbol Lt
14	532 15 97-36	Decal Chassis Hot Muffler

KEY NO.	PART NO.	DESCRIPTION
16	532 18 04-35	Decal Backplate
17	532 14 08-37	Decal Saddle Brake Parking
20	532 16 69-60	Decal Bypass Fender CRD
21	532 16 62-86	Decal Hex Belt Sch 92 CRD
—	532 18 26-21	Decal Bagger Frame
—	532 13 83-11	Decal Lift Handle
—	532 18 10-90	Pad Footrest RH
—	532 18 10-91	Pad Footrest LH
—	532 18 39-38	Manual Operator's (Euro)
—	532 18 39-39	Manual Operator's (Scan)

WHEELS & TIRES

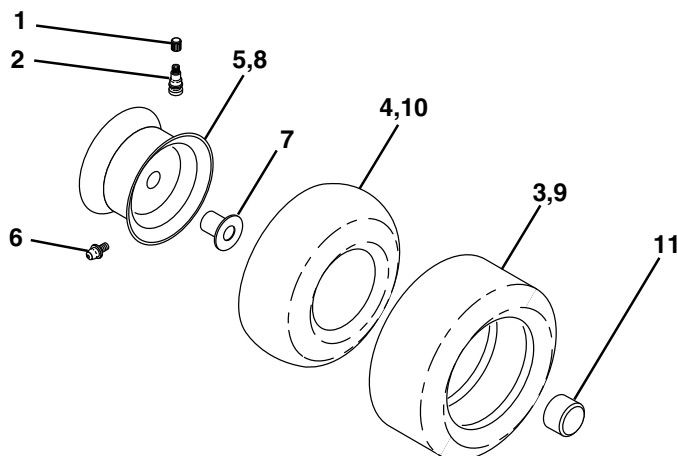

KEY NO.	PART NO.	DESCRIPTION
1	532 05 91-92	Cap Value Tire
2	532 06 51-39	Stem Value
3	532 10 62-22	Tire F Ts 15 X 6 0 - 6 Service
4	532 05 99-04	Tube Inner Front #35060
5	532 13 83-36	Rim Asm 6"front Silver Service
6	532 12 49-57	Fitting Grease
7	532 12 49-59	Bearing Flange
8	532 13 83-37	Rim Asm 8"rear Silver Service
9	532 13 84-68	Tire R Ts 20 x 8-8 Service
10	532 12 49-26	Tube Rear 9 5 X 8 Service
11	532 17 50-39	Cap Axle Blk 1 50 X 1 00
--	532 14 43-34	Sealant, Tire (10 oz. tube)

NOTE: All component dimensions given in U.S. inches
1 inch = 25.4 mm

REPAIR PARTS

TRACTOR- -MODEL NO. CTH150XP (HECTH150KA), PRODUCT NO. 954 17 00-76
ENGINE

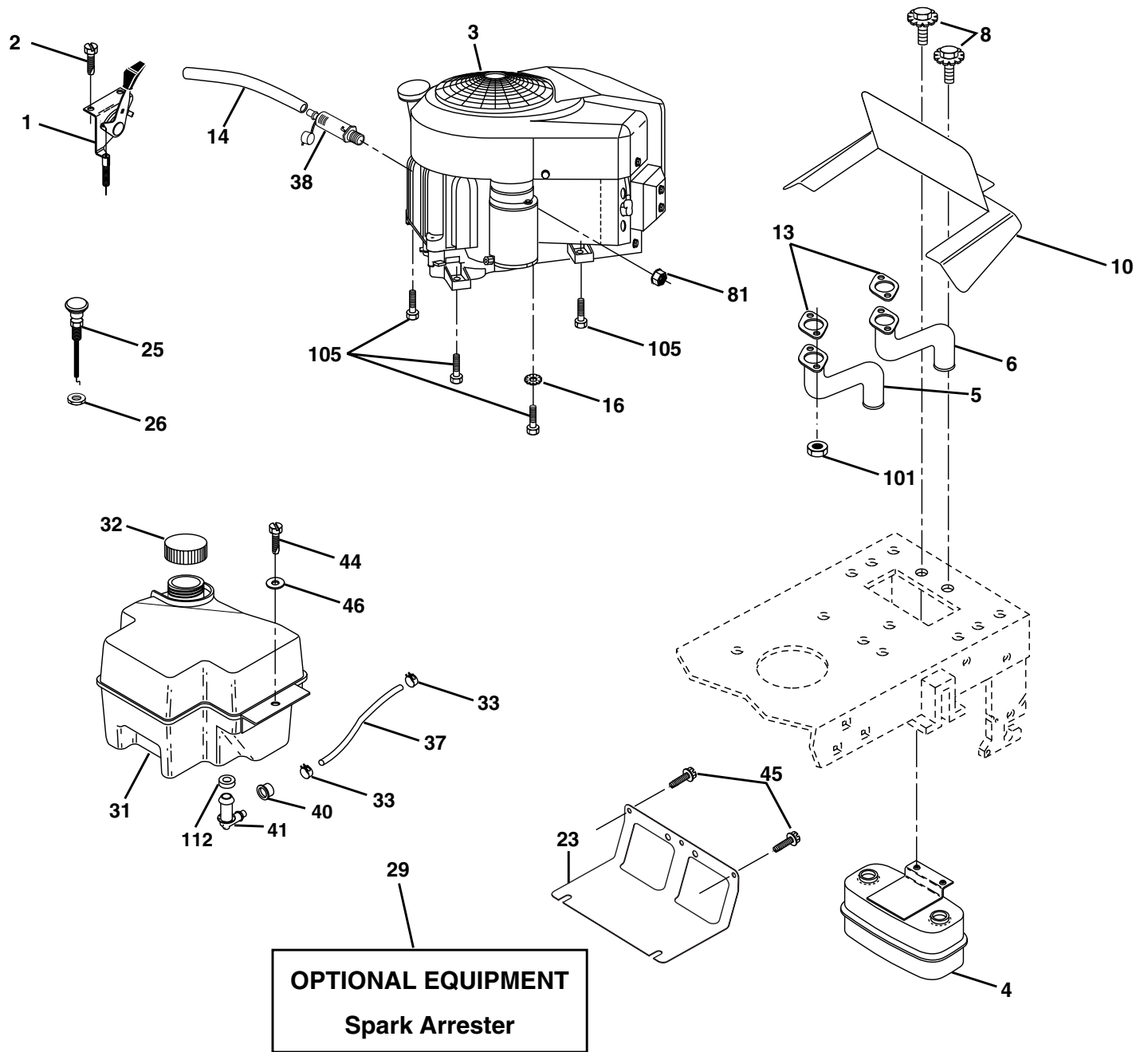

REPAIR PARTS

TRACTOR- -MODEL NO. CTH150XP (HECTH150KA), PRODUCT NO. 954 17 00-76
ENGINE

KEY NO.	PART NO.	DESCRIPTION
1	532 17 08-03	Control Throttle
2	817 72 04-08	Screw Hex Thd Cut 1/4-20 x 1/2
3	-----	Engine Kawa FH430V (Order parts from engine manufacturer)
4	532 14 97-23	Muffler Twin Lo-Twin
5	532 18 14-44	Tube, Exhaust Lh
6	532 18 14-42	Tube, Exhaust Rh
8	532 17 18-77	Bolt 5/16-18 Unc x 3/4 w/Sems
10	532 14 66-29	Shield Browning Intek
13	-----	Gasket Muffler (Order parts from engine manufacturer)
14	532 14 84-56	Tube Drain Oil Easy
16	811 05 06-00	Washer Lock Ext Tooth 3/8
23	532 16 98-37	Shield Brn/Dbr Guard
25	532 13 27-82	Choke Control 44.50
26	873 92 06-00	Nut, Keps 3/8-24 Unf
29	532 13 71-80	Kit Spark Arrestor (Flat Scrn)
31	532 18 06-45	Tank Fuel 2.00
32	532 14 05-27	Cap Asm Fuel W/sym Vented
33	532 12 34-87	Clamp Hose Blk
37	532 13 70-40	Line Fuel
38	-----	Plug Drain Oil Easy (Order parts from engine manufacturer)
40	532 12 40-28	Bushing Snap
41	532 13 92-77	Stem Tank Fuel
44	817 67 04-12	Screw Hexwsh Thdrol 1/4-20 x 3/4
45	817 00 06-12	Screw Hexwsh Thdrol 3/8-16 x 3/4
46	819 09 14-16	Washer 9/32 x 7/8 x 16 Ga.
81	873 5104-00	Nut Keps Hex 1/4-20 Unc
101	532 16 33-05	Nut Flange M8-1.25 NON-LK ZINC
105	817 12 06-16	Screw 3/8-16 x 1 SMGML TAP/R
112	532 12 49-52	Bushing

NOTE: All component dimensions given in U.S. inches
1 inch = 25.4 mm

REPAIR PARTS

TRACTOR- -MODEL NO. CTH150XP (HECTH150KA), PRODUCT NO. 954 17 00-76
MOWER LIFT

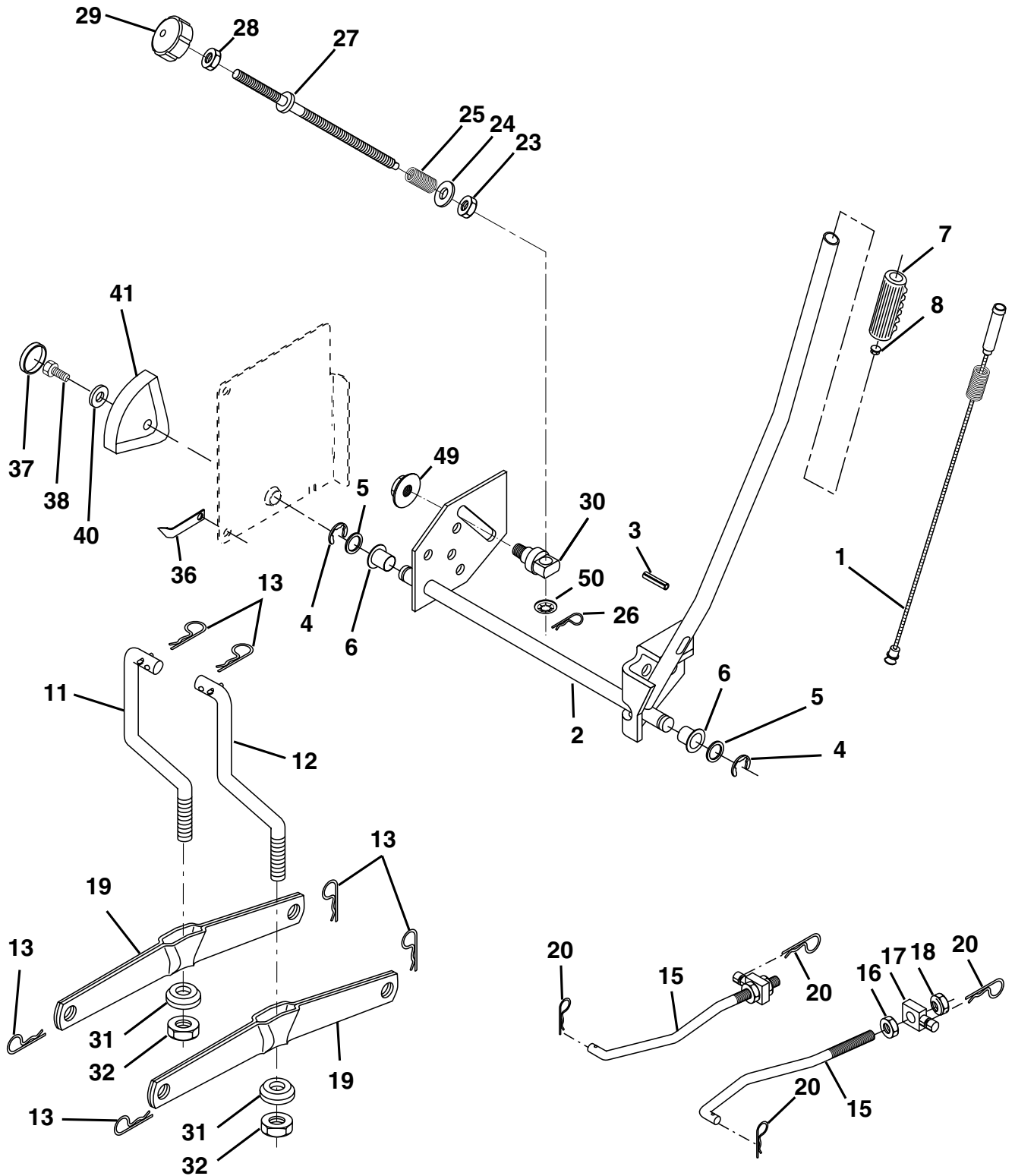

REPAIR PARTS

TRACTOR- -MODEL NO. CTH150XP (HECTH150KA), PRODUCT NO. 954 17 00-76
MOWER LIFT

KEY NO.	PART NO.	DESCRIPTION
1	532 15 94-60	Washer Asm Inner Spring W/ Plunger
2	532 15 94-71	Shaft Asm. Lift
3	532 10 57-67	Pin Groove
4	812 00 00-02	E Ring #5133-62
5	819 21 16-21	Washer 21/32 x 1 x 21 Ga.
6	532 12 01-83	Bearing Nylon
7	532 12 56-31	Grip Handle Fluted
8	532 12 45-26	Button Plunger Black
11	532 16 58-29	Link Asm Lift L.H.
12	532 16 58-31	Link Asm Lift R.H.
13	532 12 46-70	Retainer Spring
15	532 17 32-88	Link Front
16	873 35 08-00	Nut Jam Hex 1/2-13 Unc
17	532 17 56-89	Trunnion Blk Zinc
18	873 80 08-00	Nut Lock w/wsh 1/2-13 Unc
19	532 13 98-68	Arm Suspension Mower
20	532 16 35-52	Retainer Spring
23	532 11 08-07	Nut Special
24	819 13 10-16	Washer 13/32 x 5/8 x 16 Ga.
25	532 12 48-74	Spring 2-1/8"
26	532 16 94-84	Retainer Clip
27	532 12 69-71	Rod Adj Lift Zinc 7.49 Wrk Lg
28	873 35 06-00	Nut Hex Jam 3/8-16 Unc
29	532 13 80-57	Knob Inf 3/8-16 Unc Blk w/sym
30	532 15 02-33	Trunnion Infin Height
31	532 16 98-65	Bearing, Pvt. Lift.
32	873 54 06-00	Nut Crownlock 3/8-24
36	532 15 50-97	Pointer Height Indicator
37	532 12 39-35	Plug Hole Blk 1.485/1.515 Dia
38	817 06 05-16	Screw 5/16-18 x 1
40	819 11 24-10	Washer 11/32 x 1-1/2 x 10 Ga.
41	532 12 39-34	Scale Ind Height Blk
49	532 14 52-12	Nut hex Flange Lock
50	532 11 04-52	Nut Push Phos & Oil

NOTE: All component dimensions given in U.S. inches
1 inch = 25.4 mm

REPAIR PARTS

TRACTOR- -MODEL NO. CTH150XP (HECTH150KA), PRODUCT NO. 954 17 00-76

MOWER

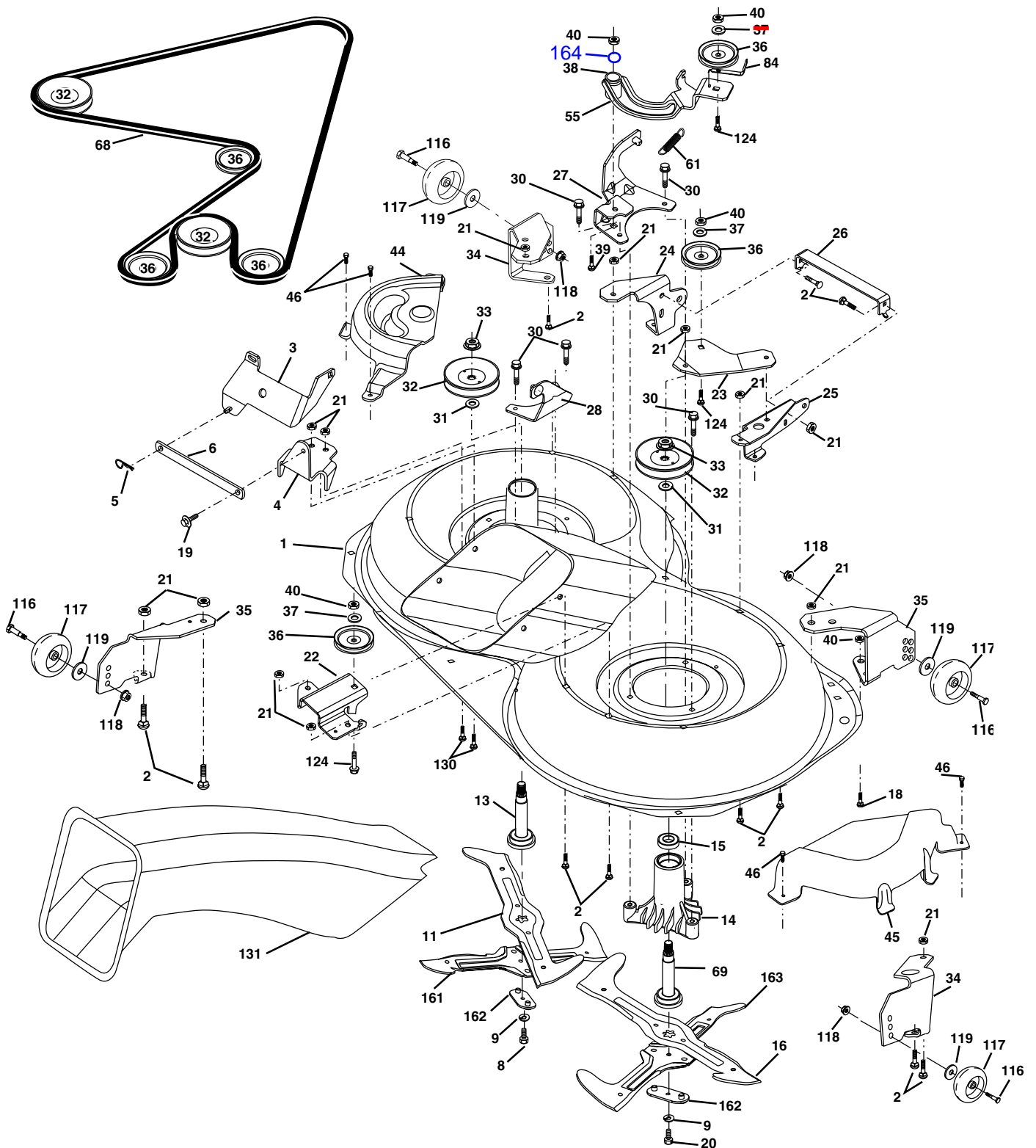

REPAIR PARTS

TRACTOR- -MODEL NO. CTH150XP (HECTH150KA), PRODUCT NO. 954 17 00-76 MOWER

Correction:

Key No.

5 532 12 46-70 Retainer Spring
18 872 11 06-06 Bolt 3/8-16 x 3/4
31 532 18 76-90 Washer Spacer Mower Vented

KEY NO.	PART NO.	DESCRIPTION
1	532 16 91-60	Housing Asm. Mower
2	872 14 05-06	Bolt Rdhd Sqnk 5/16-18 Unc x 3/4
3	532 16 55-69	Bracket Asm. S-Bar Chass
4	532 16 91-67	Bracket Bar Sway Deck
5	532 00 49-39	Retainer Spring
6	532 16 55-57	Bar Sway
8	532 18 17-12	Bolt 3/8-24 x 1.25 Gr8 Patched
9	810 03 06-00	Washer Lock Hvy 3/8 Unplated
11	532 18 05-83	Blade 3-1 Lh
13	532 13 76-45	Shaft Asm. W/Lower Bearing
14	532 12 87-74	Housing Mandrel Vented (Machd)
15	532 11 04-85	Bearing Ball Mandrel
16	532 18 05-84	Blade 3-1 Rh
18	872 11 06-08	Bolt RDHD SQNK 3/8-16 x 1 Gr. 5
19	532 13 28-27	Bolt Shoulder 5/16-18 Thd Form
20	532 18 17-13	Bolt 3/8-24 x 1.25 Gr8 Ptch Lhthd
21	873 68 05-00	Nut Crown Lock 5/16-18
22	532 16 91-65	Bracket Idler Sprt RR
23	532 16 91-66	Bracket Idler Sprt RF
24	532 16 91-70	Bracket Suspension LF
25	532 16 91-71	Bracket Suspension RF
26	532 16 52-37	Brace Support Susp Frt CRD
27	532 16 91-72	Bracket Asm. Susp RR
28	532 16 91-68	Bracket Asm. Susp LR
30	532 17 39-84	Screw Thd Rolling Dod.PT Hex
31	532 12 99-63	Washer Spacer Mower Vented
32	532 17 57-07	Mandrel Pulleys
33	532 17 83-42	Nut Flg Top Lock
34	532 17 95-09	Bracket Gauge Wheel Lf

Correction:

Key No.

40 873 90 06-00 Nut Flangelock 3/8-16 Unc
164 532 12 49-37 Bearing

KEY NO.	PART NO.	DESCRIPTION
35	532 17 62-92	Bracket Gauge Wheel Rf
36	532 14 67-63	Pulley Idler V-Groove Dim 4.25
37	819 13 13-16	Washer 11/32 x 13/16 x 16 Ga
38	532 16 98-51	Spacer Hub Arm Idler
39	872 11 06-22	Bolt RhHd 3/8-16 Unc x 2-3/4 Gr.5
40	873 68 06-00	Nut Crownlock 3/8-16 Unc
44	532 17 55-38	Cover Mandrel Lh
45	532 17 55-39	Cover Mandrel Rh
46	532 13 77-29	Screw Thd Roll 1/4-20 x 5/8
55	532 16 98-49	Arm Idler
61	532 17 51-59	Spring Tension Belt
68	532 16 91-78	Hex-Belt Mower
69	532 16 54-82	Shaft Asm W/Lwr Brg Rh Thd CRD
84	532 15 60-85	Keeper Belt Idler
116	532 18 42-19	Bolt Shoulder
117	532 13 39-57	Wheel Gage Donut Wide
118	873 93 06-00	Nut Centerlock 3/8-16 Unc
119	819 12 14-14	Washer 3/8 x 7/8 x 14 Ga.
124	872 11 06-12	Bolt Carr Sh 3/8-16 x 1-1/2 Gr5
130	872 11 05-06	Bolt Rdhdsqnk 5/16-18 Unc x 3/4
131	532 16 56-61	Chute Bagger CRD 92cm
161	532 18 04-24	Blade Cross LH 107
162	532 18 08-78	Adapter Weldment Blade 107
163	532 18 04-25	Blade Cross RH 107
--	532 18 18-57	Mandrel Asm Service
--	532 18 18-58	Mandrel Asm CRD Lh Threads VC
--	532 18 17-70	Replacement Mower Complete

NOTE: All component dimensions given in U.S. inches
1 inch = 25.4 mm

REPAIR PARTS

TRACTOR- -MODEL NO. CTH150XP (HECTH150KA), PRODUCT NO. 954 17 00-76
BAGGER

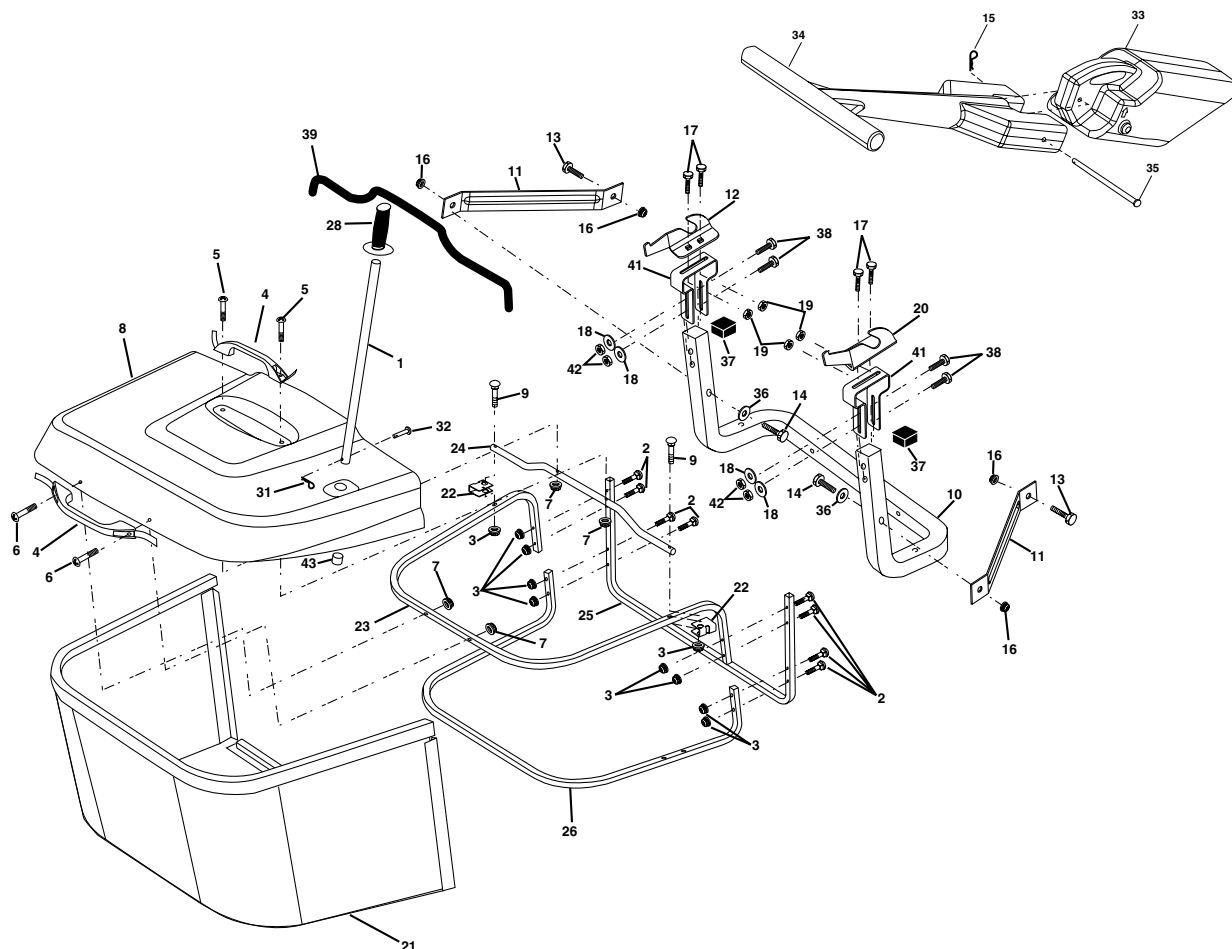

KEY NO.	PART NO.	DESCRIPTION	KEY NO.	PART NO.	DESCRIPTION
1	532 16 52-49	Tube Handle Bagger CRD	22	532 16 57-81	Bracket Side Bagger CRD
2	872 14 04-16	Bolt Carriage 1/4-20 x 2.0 Gr.5	23	532 16 57-82	Tube Upper Bagger CRD
3	532 12 39-76	Nut Lock 1/4 Lge Flg Gr. 5 Zinc	24	532 16 57-83	Tube Pivot Bagger CRD
4	532 16 99-16	Handle Bagger w/Lvrs Blk CRD	25	532 18 01-24	Tube Front Bagger CRD
5	874 98 10-24	Screw Pan Head #10-24 x 1.50 Blk	26	532 16 57-85	Tube Lower Bagger CRD
6	874 98 10-32	Screw Pan Hd	28	532 16 57-87	Grip Handle Black
7	873 40 10-00	Nut Wiz Lock Hex Serr/Hd 10-24	31	532 12 47-88	Retainer Spring 1" Zinc/Cad
8	532 18 10-95	Cover Bagger	32	532 12 68-75	Rivet Rd Hd Drilled 3/8 Dia
9	872 14 04-18	Bolt Carriage 1/4-20 x 2.25d x Gr.5	33	532 16 93-80	Plug Mulcher 107 CRD
10	532 18 12-82	Tube Support Bagger CRD	34	532 16 55-70	Handle Mulcher
11	532 16 57-19	Bracket Support Upper Bag CRD	35	532 16 55-72	Pin Mulcher
12	532 16 96-85	Bracket Horiz Adj Bagger Lh	36	819 13 20-16	Washer 13/32 x 1-1/4 x 16 Ga.
13	872 11 06-06	Bolt Rdhd Sht Sqnk 3/8-16 x 3/4	37	532 17 54-01	Plug Support Bagger CRD
14	874 52 06-36	Bolt Fin Hex 3/8-16 x 2-1/4 Gr.5	38	872 01 05-20	Bolt 5/16-18 x 2-1/2
15	532 12 46-70	Retainer Spring	39	532 18 09-85	Seal Trim
16	873 90 06-00	Nut Lock Flg 3/8-16 Unc	41	532 16 96-83	Bracket Pnt Adj Pvt Bagger CRD
17	872 14 05-06	Bolt Rdhd Sht Sqnk 5/16 -18 Unc x 3/4	42	873 80 05-00	Nut Crownlock 5/16-18 Blk D
18	819 11 12-16	Washer 11/32 x 3/4 x 16 Ga.	43	532 17 40-83	Plug Tubing End
19	873 90 05-00	Nut Lock Hex Flange 5/16-18			
20	532 16 96-84	Bracket Horiz Adj Bagger Rh			
21	532 18 08-80	Bag Asm CRD			

NOTE: All component dimensions given in U.S. inches
1 inch = 25.4 mm