

# **Operator's manual** **CZE 4818**

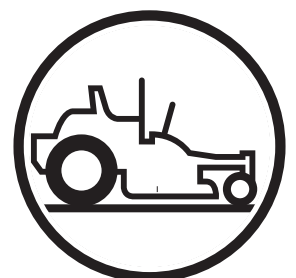

Please read these instructions carefully and make sure you understand them before using the machine.

**English**

**Congratulations** on the purchase of your **HUSQVARNA** mower. It has been designed, engineered and manufactured to give you the best possible dependability and performance. This manual has been prepared for the owners and operators of the models called out on the front cover of this manual. Read, understand and follow the safety and operating instructions. Follow a regular schedule in maintaining, caring for and using your mower. Follow the instructions under “Customer Responsibilities” and “Storage” sections of this owner’s manual.

 **WARNING**

Failure to follow cautious operating practices can result in serious injury to the operator or other persons. The owner must understand these instructions, and must allow only trained persons who understand these instructions to operate the mower. Each person operating the mower must be of sound mind and body and must not be under the influence of any mind altering substance.

 **CAUTION**

1. Keep all shields, guards and safety devices in place and in proper working condition.
2. Stop engine and remove spark plug wires or remove key before adjusting, servicing, or performing maintenance.

 **WARNING**

**This mower is equipped with an internal combustion engine and should not be used on or near any unimproved forest-covered, brush-covered or grass-covered land unless the engine’s exhaust system is equipped with a spark arrester meeting applicable local or state laws (if any). If a spark arrester is used, it should be maintained in effective working order by the operator.**

A spark arrester for the muffler is available through your nearest authorized engine service center/department.

 **WARNING**

**Engine exhaust, some of its constituents, and certain vehicle components contain or emit chemicals known to the State of California to cause cancer and birth defects or other reproductive harm.**

 **WARNING**

**Battery posts, terminals and related accessories contain lead and lead compounds, chemicals known to the State of California to cause cancer and birth defects or other reproductive harm. Wash hands after handling.**

Continuous dedication to improve our products require that specifications and design are subject to change without notice.

# CONTENTS

<b>SYMBOLS &amp; DECALS</b> .....	4	Air Screen & Air Filter .....	26
<b>SAFETY INSTRUCTIONS</b> .....	5	Oil Filter .....	26
General use and safety rules .....	5	Spark Plugs .....	26
Driving on slopes .....	7	Fuel Filter .....	26
Children safety .....	8	Cleaning .....	26
Service safety .....	8	<b>SERVICE AND ADJUSTMENT</b> .....	27
Transportation .....	10	Mower .....	27
<b>SPECIFICATIONS</b> .....	11	Deck Level .....	27
<b>ASSEMBLY</b> .....	12	Deck Belt Replacement .....	28
Tools Required .....	12	IZT (Integrated Zeroturn Transaxle) Belt Replacement .....	29
Unpacking .....	12	Seat Adjustment .....	30
Seat Attachment .....	12	Control Levers Adjustment .....	30
Control Lever Attachment .....	12	Wheel Removal .....	30
Check Tire Pressure .....	14	Jump Starting Engine .....	30
Assembly Checklist .....	14	Battery Replacement .....	31
<b>OPERATION</b> .....	15	Park Brake .....	31
Controls .....	15	Tracking Adjustment .....	32
Operation Instructions .....	16-21	<b>STORAGE</b> .....	33-34
<b>CUSTOMER RESPONSIBILITIES</b> .....	22	<b>TROUBLESHOOTING</b> .....	35-36
Maintenance Schedule .....	22	<b>WIRING SCHEMATIC</b> .....	37
Lubrication Chart .....	23		
Tires .....	23		
Operator Presence System .....	23		
Blade Care .....	23		
V-Belts .....	25		
Engine .....	25		

# SYMBOLS AND DECALS

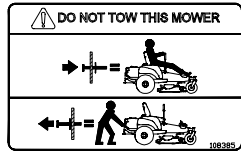
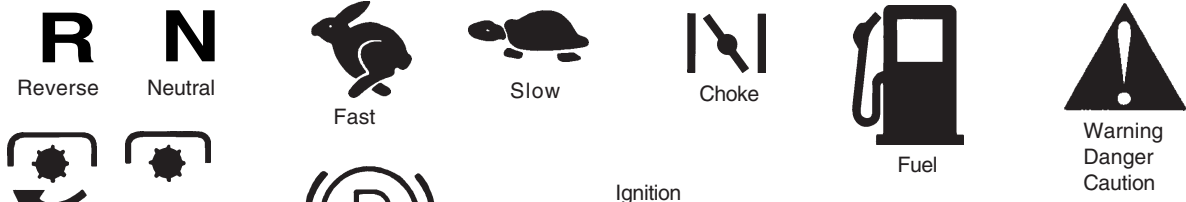

Do not tow or push mower unless you engage the IZT (Intergraded Zerturn Transaxle) bypass linkages

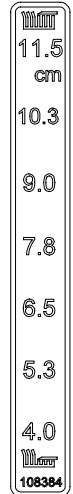

Cutting height

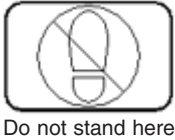

Do not stand here



Do not put pressure on drive levers. Read Operator's Manual.



Battery acid is corrosive, explosive, and flammable.

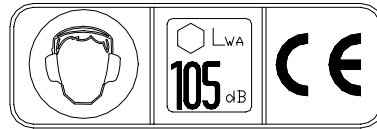

Use ear protection

Sound power

CE conformity marking



Do not touch rotating parts.

### SERVICE CHART

- GREASE LUBE POINTS EVERY 25 HOURS.
- 2** CHECK TIRE AIR PRESSURE  
FRONT TIRES - 15 PSI - REAR TIRES - 15 PSI  
SEE OPERATORS MANUAL FOR MORE INFORMATION.
- 3** REFER TO ENGINE OPERATORS MANUAL PRIOR TO SERVICING THE ENGINE.

Read Operator's Manual	Shut off engine & remove key before performing any maintenance or repair work.	Keep a safe distance from the machine.	Use on slopes no greater than 10°	No passengers
Whole body exposure to thrown objects.	Severing of fingers & toes.	Do not open or remove safety shields while engine is running.	Careful backing up, watch for other people.	Careful going forward, watch for other people.

# SAFETY INSTRUCTIONS

## Safety Instructions

These instructions are for your safety. Read them carefully.



### WARNING!

This symbol means that important safety instructions need to be emphasized. It concerns your safety.

### General Use

- Read all instructions in this operator's manual and on the machine before starting it. Ensure that you understand them and then abide by them.
- Learn how to use the machine and its controls safely and learn how to stop quickly. Also learn to recognize the safety decals.
- Only allow the machine to be used by adults who are familiar with its use.
- Make sure nobody else is in the vicinity of the machine when you start the engine, engage the drive, or run the machine.
- Make sure animals and people maintain a safe distance from the machine.
- Stop the machine if someone enters the work area.
- Clear the area of objects such as stones, toys, steel wire, etc. that may become caught in the blades and thrown out.
- Beware of the discharge deck and do not point it at any one. Do not use the machine without the discharge deck in place.
- Stop the engine and prevent it from starting before you clean the discharge deck.
- Remember that the operator is responsible for dangers or accidents.
- Never take passengers. The machine is only intended for use by one person.
- Always look down and behind before and during reversing maneuvers. Keep a look out for both large and small obstacles.
- Slow down before turning.
- Shut down the blades when not mowing.

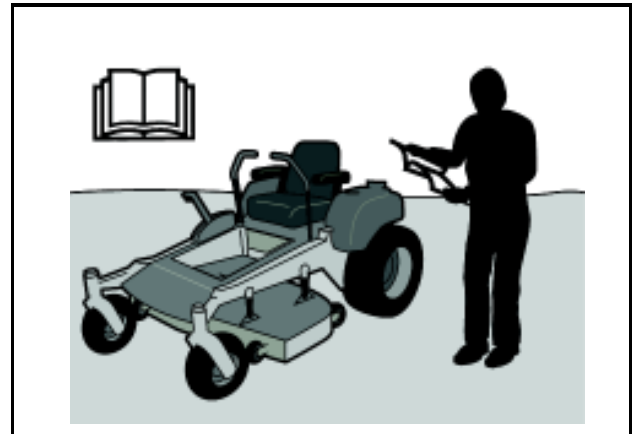

8011-512  
*Read the operator's manual before starting the machine*

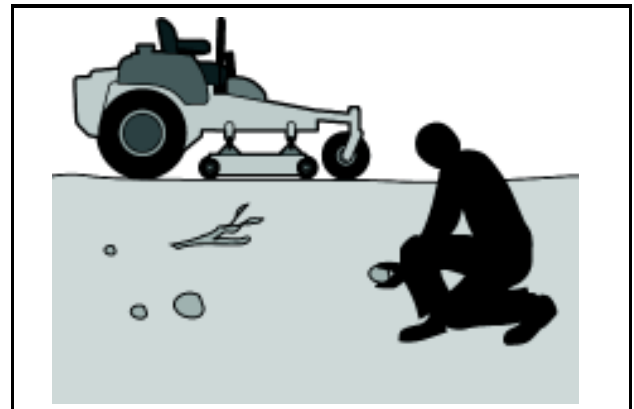

8011-513  
*Clear the area of objects before mowing*



8011-520

# SAFETY INSTRUCTIONS

- Be careful when rounding fixed objects, so that the blades do not hit them. Never drive over foreign objects.
- Only use the machine in daylight or in other well-lit conditions. Keep the machine a safe distance from holes or other irregularities in the ground. Pay attention to other possible risks.
- Never use the machine if you are tired, if you have consumed alcohol, or if you are taking other drugs or medication that can affect your vision, judgment, or coordination.
- Beware of traffic when working near or crossing a road.
- Never leave the machine unsupervised with the engine running. Always shut down the blades, pull back the parking brake, stop the engine, and remove the ignition key before leaving the machine.
- Never allow children or other persons not trained in the use of the machine to use or service it. Local laws may regulate the age of the user.



## WARNING!

Engine exhaust and certain vehicle components contain or emit chemicals considered to cause cancer, birth defects, or other reproductive system damage. The engine exhaust contains carbon monoxide, which is a colorless, poisonous gas. Do not use the machine in enclosed spaces.



8011-518



## WARNING!

When using the machine, approved personal protective equipment shall be used. Personal protective equipment cannot eliminate the risk of injury but it will reduce the degree of injury if an accident does happen. Ask your retailer for help in choosing the right equipment.

- Make sure that you have first aid equipment close at hand when using the machine.
- Never use the machine when barefoot. Always wear protective shoes or boots, preferably with steel toecaps.
- Always wear approved protective glasses or a full visor when assembling or driving.
- Never wear loose clothing that can get caught in moving parts.



Personal protective equipment

8011-292

# SAFETY INSTRUCTIONS

## Driving on Slopes

Driving on slopes is one of the operations where the risk is greatest that the driver will lose control or the machine will tip over, which can result in serious injury or death. All slopes require extra caution. If you cannot reverse up a slope or if you feel unsure, do not mow the slope.

### Do as follows

- Remove obstacles such as stones, tree branches, etc.
- Mow up and down, not side-to-side.
- Never drive the rider on terrain that slopes more than 10°.
- Avoid starting or stopping on a slope. If the tires begin to slip, shut down the blades and drive slowly down the slope.
- Always drive evenly and slowly on slopes.
- Make no sudden changes in speed or direction.
- Avoid unnecessary turns on slopes, and if it proves necessary, turn slowly and gradually downward, if possible.
- Watch out for and avoid driving over furrows, holes, and bumps. On uneven terrain, the machine can tip more easily. Long grass can hide obstacles.
- Drive slowly. Use small movements of the steering controls.
- Be extra cautious with any additional equipment, which can alter the machine's stability.
- Do not mow near verges, ditches, or banks. The machine can suddenly spin around if a wheel goes over the edge of a drop or ditch, or if an edge gives way.
- Do not mow wet grass. It is slippery, and the tires can lose their grip, so that the machine slides.
- Try not to stabilize the machine by putting a foot on the ground.
- When cleaning the chassis, the machine may never be driven near verges or ditches.

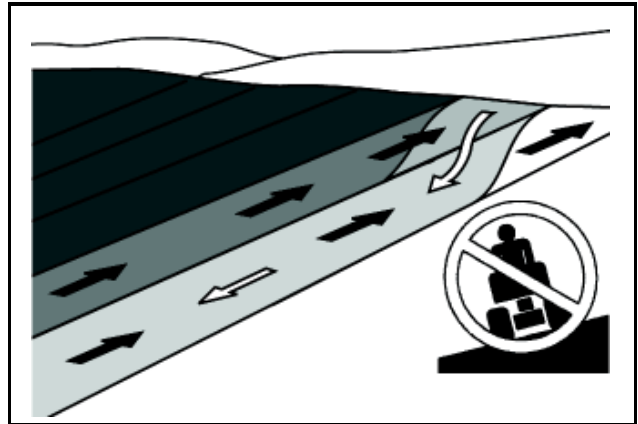

*Mow up and down, not side-to-side*

8003-004



*Be extra cautious when driving on slopes*

8011-519

# SAFETY INSTRUCTIONS

## Children

- Serious accidents may occur if you fail to be on guard for children in the vicinity of the machine. Children are often attracted to the machine and mowing work. Never assume that children will stay put where you last saw them.
- Keep children away from the mowing area and under close supervision by another adult.
- Keep an eye out and shut off the machine if children enter the work area.
- Before and during a reversing maneuver, look backward and downward for small children.
- Never allow a child to ride with you. They can fall off and injure themselves seriously or prevent risk-free maneuvering of the machine.
- Never allow children to operate the machine.
- Be particularly cautious near corners, bushes, trees, or other objects that block your view.

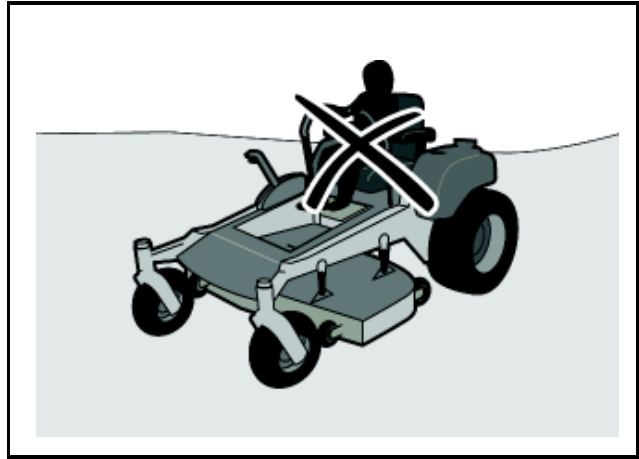

*Never allow children to operate the machine*

8011-517



### **WARNING!**

**The engine must not be started when the driver's floor plate or any protective plate for the mower deck's drive belt is removed.**

- Stop the engine. Prevent the engine from starting by removing the ignition key before making any adjustments or performing maintenance.
- Never fill the fuel tank indoors.
- Fuel and fuel fumes are poisonous and extremely flammable. Be especially cautious when handling fuel, as carelessness can result in personal injury or fire.
- Only store fuel in containers approved for the purpose.
- Never remove the fuel tank cap and never fill the fuel tank while the engine is running.



*Never fill the fuel tank indoors*

8011-516



## SAFETY INSTRUCTIONS

- Allow the engine to cool before refueling. Do not smoke. Do not fill fuel in the vicinity of sparks or open flames.
- If leaks arise in the fuel system, the engine must not be started until the problem has been resolved.
- Store the machine and fuel in such a way that there is no risk of leaking fuel or fuel vapor leading to damages.
- Check the fuel level before each use and leave space for the fuel to expand, because the heat from the engine and the sun may otherwise cause the fuel to expand and overflow.
- Avoid overfilling. If you spill fuel on the machine, wipe up the spill and wait until it has evaporated before starting the engine. If you have spilled fuel on your clothing, change your clothing.
- Allow the machine to cool before taking any actions in the engine compartment.
- Be very careful when handling battery acid. Acid on skin can cause serious corrosive burns. If you spill battery acid on your skin, rinse immediately with water.
- Acid in the eyes can cause blindness, contact a doctor immediately.
- Be careful when servicing the battery. Explosive gases form in the battery. Never perform maintenance on the battery when smoking or near open flames or sparks. The battery can explode and cause serious injury/damage.
- Ensure that nuts and bolts, especially the fastening bolts for the blade attachments, are properly tightened and that the equipment is in good condition.
- Do not modify safety equipment. Check regularly to be sure it works properly. The machine must not be driven with defective or unmounted protective plates, protective cowlings, safety switches, or other protective devices.
- Do not change the settings of governors and avoid running the engine with overly high engine speeds. If you run the engine too fast, you risk damaging the machine components.



### WARNING!

**The engine, the exhaust system, and the hydraulic system's components become very warm during operation.**

**Risk for burns if touched.**



### WARNING!

**The battery contains lead and lead compounds, chemicals that are considered to cause cancer, birth defects, and other reproductive system damage.**

**Wash your hands after touching the battery.**

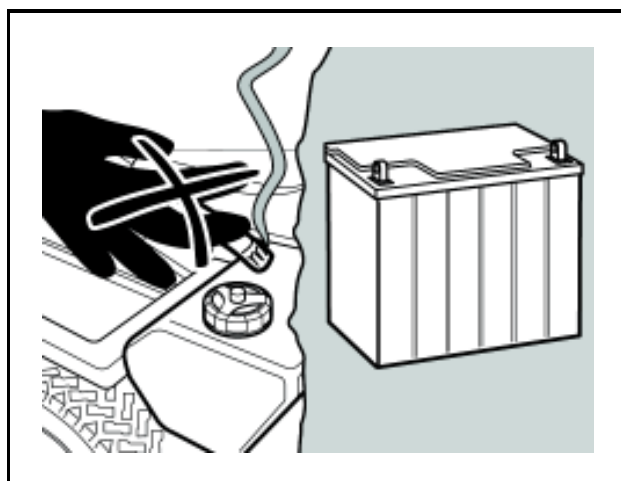

8011-563

*Do not smoke when performing maintenance on the battery. The battery can explode and cause serious injury/damage*

# SAFETY INSTRUCTIONS

- Never use the machine indoors or in spaces lacking proper ventilation. The exhaust fumes contain carbon monoxide, an odorless, poisonous, and lethal gas.
- Stop and inspect the equipment if you run over or into anything. If necessary, make repairs before starting.
- Never make adjustments with the engine running.
- The machine is tested and approved only with the equipment originally provided or recommended by the manufacturer.
- The blades are sharp and can cause cuts and gashes. Wrap the blades or use protective gloves when handling them.
- Check the parking brake's functionality regularly. Adjust and service as necessary.
- The mulch deck shall only be used when higher quality mowing is desired in familiar areas.
- Reduce the risk of fire by removing grass, leaves, and other debris that may have accumulated on the machine. Allow the machine to cool before putting it in storage.

## Transport

- The machine is heavy and can cause serious crushing injuries. Be extra cautious when it is loaded on or unloaded from a vehicle or trailer.
- Use an approved trailer to transport the machine. Activate the parking brake, turn off the fuel supply, and fasten the machine with approved fastening devices, such as bands, chains, or ropes, when transporting.
- Check and abide by local traffic regulations before transporting or driving the machine on any road.

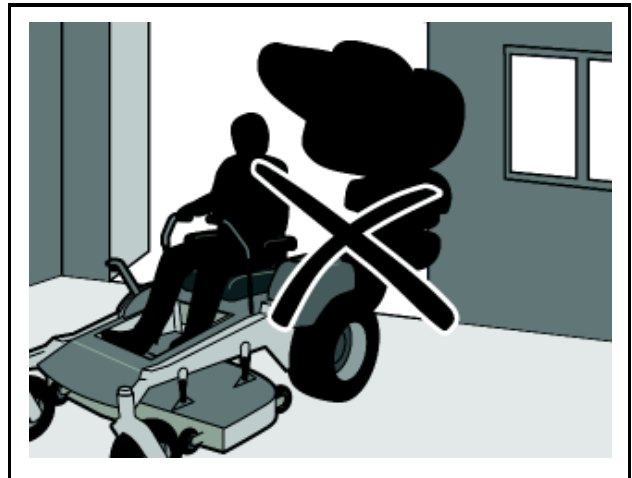

Never drive the machine in an enclosed space

8011-515

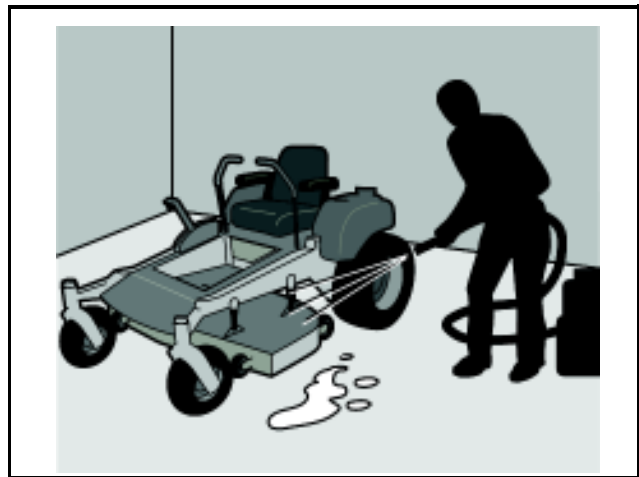

Clean the machine regularly

8011-514

## IMPORTANT INFORMATION

**The parking brake is not sufficient to lock the machine in place during transport. Ensure that the machine is well fastened to the transport vehicle. Reverse the machine onto the transport vehicle to avoid tipping it over.**

---

## SPECIFICATIONS

---

GASOLINE CAPACITY AND TYPE	5.6 GALLONS UNLEADED REGULAR
OIL TYPE (SPI-SF-SJ):	SEE YOUR ENGINE OWNERS MANUAL
SPARK PLUG:	SEE ENGINE MANUAL
GROUND SPEED (MPH):	FORWARD: 0 - 5.5 REVERSE: 0 - 2.5
TIRE PRESSURE:	FRONT: 15 PSI REAR: 15 PSI
CHARGING SYSTEM:	KAWASAKI 13 AMP @ 3600 RPM
BATTERY:	MIN. CCA: 300 CASE SIZE: 5 1/4W X 7 3/4 L X 6 T
BLADE BOLT TORQUE:	45-55 FT./LBS.

---

# ASSEMBLY

---

Your new mower has been assembled at the factory with the exception of those parts left un-assembled for shipping purposes. To ensure safe and proper operation of your mower, all parts and hardware you assemble must be tightened securely. Use the correct tools as necessary to insure proper tightness.

## TOOLS REQUIRED FOR ASSEMBLY

1. 9/16" wrench or 9/16" socket w/ drive ratchet
2. Tire pressure gauge
3. Nail bar or claw hammer
4. Wire snips

When right or left hand is mentioned in this manual, it means when you are in the operating position (seated).

## TO REMOVE THE MOWER FROM CRATE

### UNPACK CRATE

- Using the nail bar or hammer, remove the top of the crate first. Then remove the sides of the crate and place these out of the way. Be careful of any exposed nails or staples.
- Remove the plastic bag that covers the mower.
- Using the wire snips, cut any plastic ties that are holding the mower to the crate.
- Remove the seat off of the front of the mower and place in a safe location.

## BEFORE REMOVING THE MOWER FROM THE SKID

### ATTACH SEAT (See Fig. 1)

The seat position should be adjusted forward or backward so that the operator can comfortably reach the deck lift pedal and safely operate the mower. See "Service and Adjustment" Section of this manual.

- Remove protective wrap from the seat.
- Remove the three prong knobs and washers from the seat and place in the storage area in the right side console.
- Raise the seat pan up so that the bottom can be easily accessed.

- Securing one of the three prong knobs and washers, insert it thru the seat pan slot and into the corresponding threaded hole in the seat bottom.
- Repeat for the other three holes.
- Tighten the three prong knobs in the approximate position desired for the seat.
- Connect the wiring harness to the seat switch.

Adjustments may be required to position the seat in the desired position. Refer to the "Service and Adjustment" section of this manual.

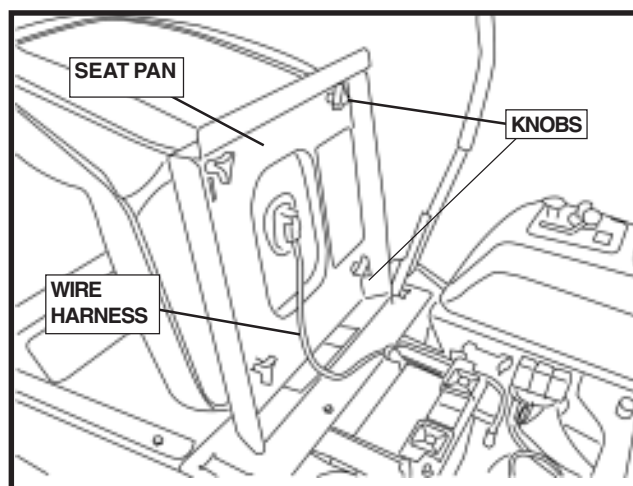

FIGURE 1

CZ-1

### ATTACH CONTROL LEVERS (See Fig. 2)

- Using the 9/16" wrench or socket and ratchet, remove the bottom hex bolt and spring washer from the control arm.
- Rotate the control lever up until the bolt and spring washer can be placed thru the slot in the bottom of the control lever and threaded back into the control arm.
- Center the hex bolt in the slot on the control lever. Using the wrench or ratchet, tighten both the top and bottom hex bolts.
- Repeat on opposite side of the mower.

---

## ASSEMBLY

---

Adjustments may be required to get uniform positioning of the control lever. Refer to the "Service and Adjustment" section of this manual.

**NOTE:** You may now roll or drive the mower off of the skid. Follow the appropriate instruction below to remove the mower from the skid.

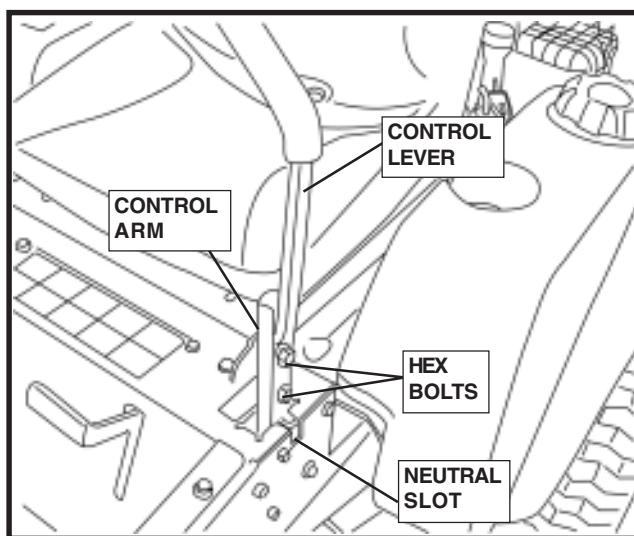

FIGURE 2

### TO ROLL THE MOWER OFF OF THE SKID (See Operation section for location and function of controls)

- Move to the rear of the mower, and place the IZT (Integrated Zereturn Transaxle) bypass linkages into the bypass position to disengage the IZT's (See "TO TRANSPORT" in the Operation section of this manual).
- Sitting on the mower, press the deck lift pedal in to the highest cutting position.
- Release park brake lever.
- Roll the mower forward or backward off of the skid.

### TO DRIVE THE MOWER OFF OF THE SKID (See Operation section for location and function of controls)



#### WARNING

Before starting, read, understand and follow all instructions in the Operation section of this manual. Be sure the mower is in a well-ventilated area. Be sure the area in front of the mower is clear of other people and objects.

- Be sure all of the above assembly steps have been completed.
- Check engine oil level and fill fuel tank with gasoline.
- Place the IZT(Integrated Zereturn Transaxle) bypass linkages into the drive position (See "TRANSPORT" in the Operation section of this manual).
- Sit on the seat in the operating position, set the park brake lever to the on position.
- Rotate the control levers outward into the neutral slot.
- Press forward on the deck lift pedal to raise the deck into the highest cutting position.
- Place the throttle control into the choke position.
- Start the engine. After the engine has started, move the throttle control to the idle position.
- Release the park brake.
- Move the control levers into the operate position.
- Slowly move the control levers forward and slowly drive the mower off of the skid.
- Return the control levers back to the neutral position.
- Apply the park brake.
- Turn the ignition key to the "OFF" position.

---

# ASSEMBLY

---

## CHECK THE TIRE PRESSURE

Correct tire pressure is important for best cutting performance.

- Check the tire pressure and adjust accordingly. Refer to the “SPECIFICATIONS” section in this manual.

## CHECKLIST

*PLEASE REVIEW THE FOLLOWING CHECKLIST*

- All assembly instructions have been completed
- No remaining loose parts in crate
- Seat is adjusted properly and securely fastened
- All tires are properly inflated
- Check wiring. See that all connections are still secure, and wires are properly clamped.
- Before driving the mower, be sure the IZT(Integrated ZeroTurn Transaxle) bypass linkages are in the drive position.

*WHILE LEARNING HOW TO USE YOUR MOWER, PAY EXTRA ATTENTION TO THE FOLLOWING ITEMS:*

- Engine oil is at proper level
- Fuel tank is filled with fresh, clean, regular unleaded gasoline. Check your engine manual for fuel requirements.
- Become familiar with all controls – their location and function. Operate them before you start the engine.
- Become familiar with unit operation on a flat and level area with the mower deck shut off.
- Be sure the brake system is in a safe operating condition. If adjustment is needed see Service and Adjustment section.

# OPERATION

## CONTROLS

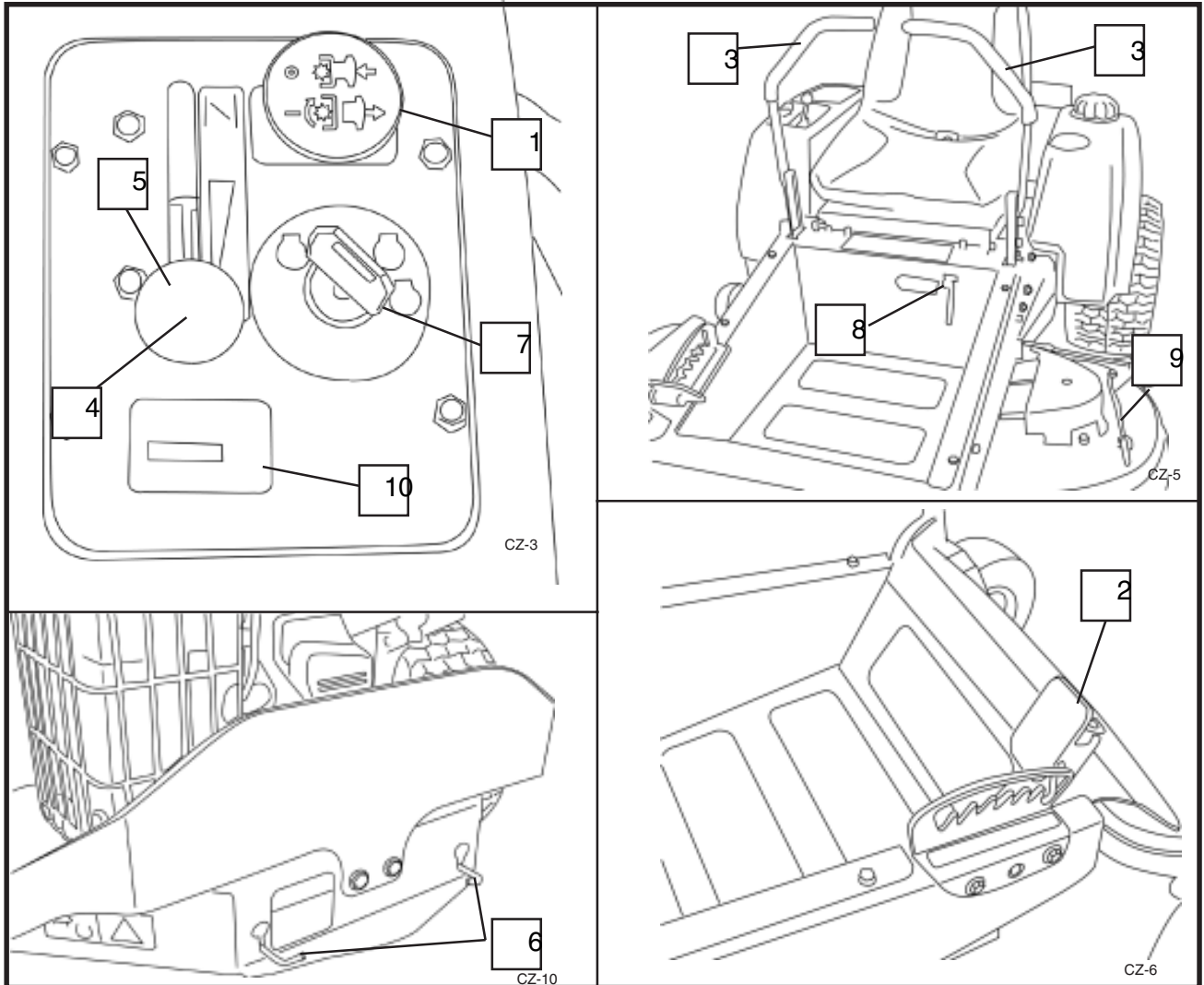

**FIGURE 3**

- 1. PTO SWITCH** – Used to engage or disengage the deck blades.
- 2. FOOT PEDAL** – Used to raise, lower and select various cutting heights of the deck.
- 3. CONTROL LEVERS** – Sets the speed of the mower in both forward and reverse directions and turns the mower.
- 4. CHOKE CONTROL** – Used when starting a cold engine.
- 5. THROTTLE CONTROL** – Used to control Engine Speed.
- 6. IZT (Integrated Zereturn Transaxle) BYPASS LINKAGES** – Bypasses IZT's for pushing or pulling mower.
- 7. IGNITION SWITCH** – Used to start or stop the engine.
- 8. PARKING BRAKE LEVER** – Engages and disengages the park brakes.
- 9. TENSION RELIEF LEVER** – Used to release the belt tension on the deck belt for ease in removing or replacing the belt.
- 10. HOUR METER** – Indicates hours of operation.

---

# OPERATION

---

## HOW TO USE YOUR MOWER

### TO SET PARKING BRAKE (See Fig. 3)

Your mower is equipped with an operator presence system. When the engine is running, any attempt by the operator to leave the seat without first setting the park brake will shut off the engine.

- Pull park brake lever up and to the right to engage the park brake. Make sure the lever is secured to the right.

### DECK BLADES

- To stop the deck blades, press down on the PTO Switch into the disengaged position.

### ENGINE

- Move throttle control to slow position.

**NOTE:** Failure to move the throttle control to slow position and allow engine to idle before stopping may cause engine to “backfire”.

- Turn ignition key to “OFF” position and remove key. Always remove key when leaving the mower to prevent unauthorized use.
- Never use choke to stop engine.

**IMPORTANT:** LEAVING THE IGNITION SWITCH IN ANY POSITION OTHER THAN “OFF” WILL CAUSE THE BATTERY TO BE DISCHARGED, (DEAD).



### TO USE THROTTLE CONTROL (See Fig. 3)

Always operate engine at full throttle. The Throttle control is equipped with a choke detent. Pressing the throttle control all of the way forward will choke the engine. For full throttle, press throttle control forward until you feel resistance.

- Operating engine at less than full throttle reduces the battery charging rate
- Full throttle offers the best mower performance.

### TO USE CHOKE CONTROL (See Fig. 3)

Use choke control whenever you are starting a cold engine. Do not use to start a warm engine.

- To choke, press the throttle control as far forward as it will go.
- To take out of choke, pull back on the throttle control until it clicks.

### TO MOVE FORWARD AND BACKWARD (See Fig. 4)

**IMPORTANT:** CONTROL LEVERS RETURN TO NEUTRAL WHEN RELEASED. THIS MAY CAUSE A SUDDEN STOP OF THE MOWER.

The direction and speed of movement is controlled by the control levers on either side of the mower.

The left lever controls the flow of oil in the left IZT (Integrated Zereturn Transaxle) to the left wheel. The right lever controls the flow of oil in the right IZT to the right wheel.

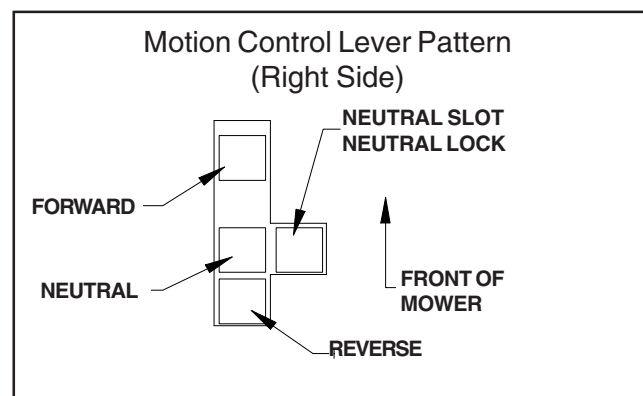

FIGURE 4



## OPERATION

NOTE: To begin motion the operator must be in the seat and the parking brake disengaged before the motion control levers can be moved from the neutral slots or the engine will kill. Fig. 4 and 4A.

By moving the levers an equal amount forward or back the machine will move in a straight line in that direction. Fig. 4 and 4A

Movement of either lever forward will cause the right or left wheel to rotate in a forward direction. To stop movement pull both levers into the neutral position.

To turn right while moving in a forward direction pull the right lever back towards the neutral position, this will slow the rotation of the right wheel and cause the machine to turn in that direction.

To turn left while moving in a forward direction pull the left lever back towards the neutral position, this will slow the rotation of the left wheel and cause the machine to turn in that direction.

To zero turn pull one lever back beyond neutral while holding the other slightly ahead of neutral.

NOTE: The direction of the zero turn will be determined by which lever is pulled back beyond neutral. Thus left lever back, left zero turn and opposite for right zero turn.

**Use extra care when using this maneuver the machine can spin very rapidly if one lever is positioned too far ahead of the other.**



### CAUTION

**DO NOT apply excessive force to control levers or use to assist in dismounting unit. Misuse will result in bent control levers.**

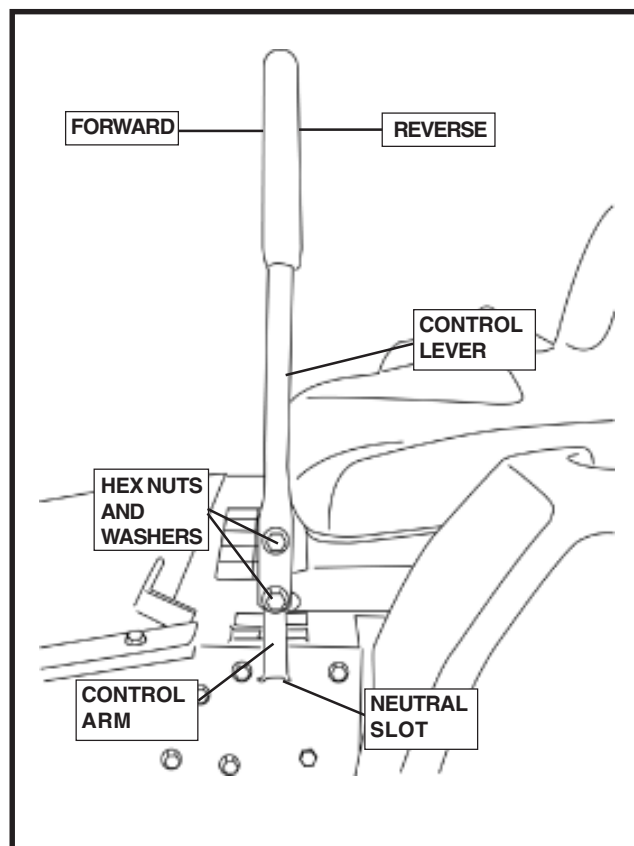

CZ-7

FIGURE 4A

### TO ADJUST THE DECK CUTTING HEIGHT (See Fig. 5)

The deck cutting height is obtained by pressing the foot pedal forward to lift the deck. To lower the deck, you apply pressure to the top side of the foot pedal and allow it to pivot while allowing the lift arm to rotate to the rear of the unit. To stop in a desired cutting position, rotate the foot pedal down into the notch in the height plate. The cutting height range is from 1 1/2" to 4 1/2" in 1/2" increments. The heights are measured from the ground up to the blade tip with the engine not running.

- The average lawn should be cut to 2 1/2" during the cool season and to over 3" during the hot months. For healthier and better looking lawns, mow often and after moderate growth.
- For best cutting performance, grass over 6 inches in height should be mowed twice. Make the first cut relatively high; the second to the desired height.

# OPERATION

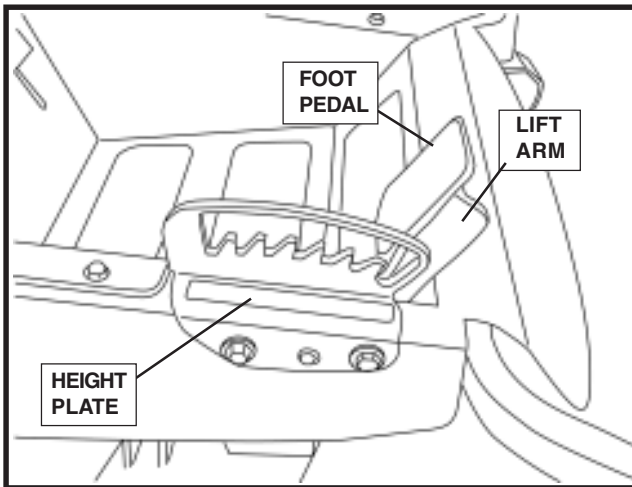

CZ-8

FIGURE 5

## TO ADJUST ANTI-SCALP ROLLERS (See Figure 6)

Anti-scalp rollers are properly adjusted when they are just slightly off of the ground when the deck is at the desired cutting height in the operating position. Anti-scalp rollers then keep the deck in the proper position to help prevent scalping in most terrain conditions.

**NOTE:** Adjust Anti-scalp rollers with the mower on a flat level surface.

- Adjust the deck to the desired cutting height (see "TO ADJUST DECK CUTTING HEIGHT" in the operation section of this manual).
- Using a 3/4" wrench and a 9/16" wrench, remove the nut and shoulder bolt from the anti-scalp roller.
- Lower the anti-scalp roller to the ground, and raise it up to the next highest hole.
- Replace and tighten the nut and shoulder bolt.
- Be sure to adjust all of the anti-scalp rollers to the same position.
- Be sure to readjust the anti-scalp rollers if the cutting height is changed.

**IMPORTANT:** THE ANTI-SCALP ROLLERS MUST NOT BE USED FOR GAUGE WHEELS OR THE ROLLER AND DECK MAY BE DAMAGED.

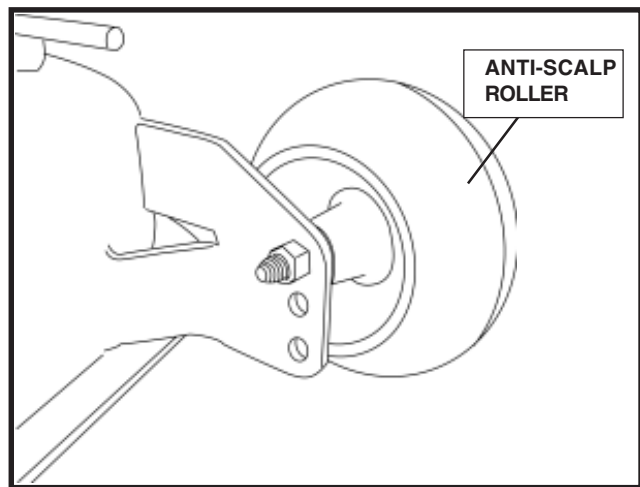

CZ-9

FIGURE 6

## TO OPERATE MOWER

Your mower is equipped with an operator presence system. When the engine is running, any attempt by the operator to leave the seat without first setting the park brake will shut off the engine.

- Select desired height of cut.
- Start deck blades by pulling the PTO switch up into the engaged position.
- To stop the deck blades, press down on the PTO Switch into the disengaged position.



### WARNING

**Do not operate the deck without either the entire grass catcher, mulch kit or discharge chute installed.**

## TO OPERATE ON HILLS



### WARNING

**Do not drive up or down hills with slopes greater than 10 degrees. And do not drive across any slopes.**

# OPERATION

- The slowest speed possible should be used before starting up or down hills.
- Avoid stopping or changing speed on hills.
- If stopping is absolutely necessary, pull drive levers into the neutral position and push to the outside of the unit and engage the park brake.

**IMPORTANT:** Control levers return to neutral when released. This may cause a sudden stop of the mower.

- To restart movement, release the park brake.
- Pull the control levers back to the center of the mower and press forward to regain forward motion.
- Make all turns slowly.

## TO TRANSPORT (See Fig. 7)

When pushing or pulling the mower, be sure to engage the IZT (Integrated Zeroturn Transaxle) bypass linkages. The IZT bypass linkages are located on the rear of the frame, below the rear engine guard.



### CAUTION

**Do not tow this vehicle, it may cause damage to the drive system.**

- Raise the deck into the highest cutting position.
- Pull the IZT bypass linkages out and into the slots and release so that it is held in the bypass position.
- To reengage the IZT's to drive, reverse the above procedure.



### WARNING

**Do not tow any trailers, etc. with this mower. They may jackknife or overturn causing damage to the mower and possibly serious injury to the operator.**

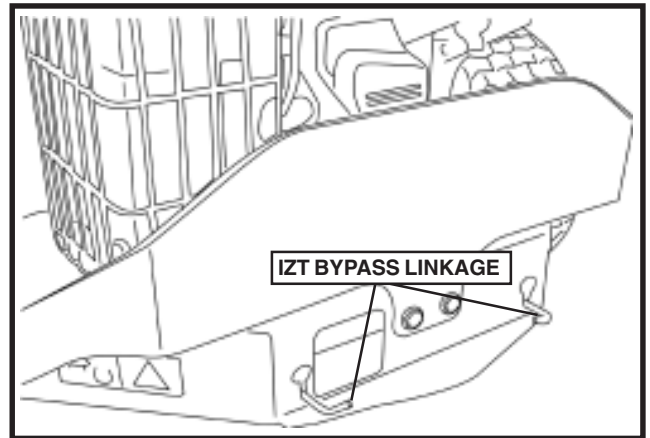

CZ-10

FIGURE 7

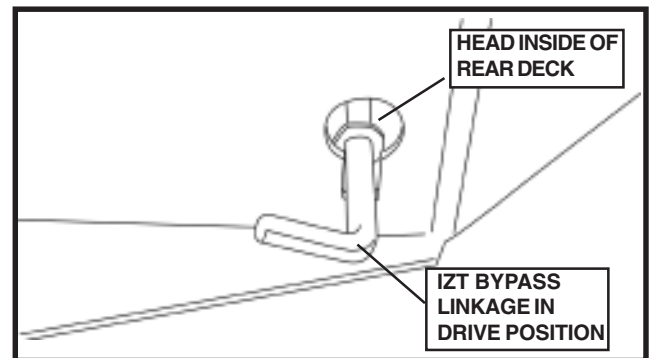

CZ-11

FIGURE 7A

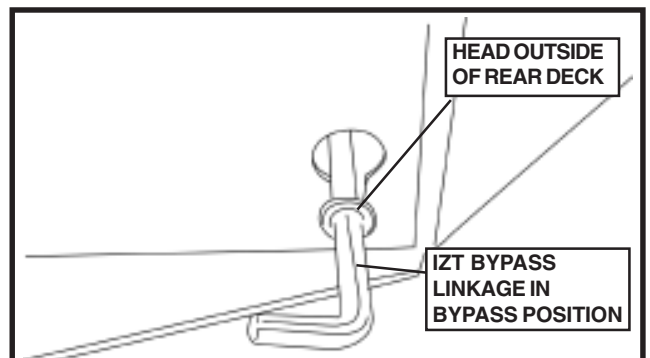

CZ-12

FIGURE 7B

---

# OPERATION

---

## BEFORE STARTING THE ENGINE

### CHECK ENGINE OIL LEVEL

- The engine in your mower has been shipped from the factory, already filled with 10W-30 motor oil.
- Check engine oil with the mower on level ground.
- Refer to your Engine Owners Manual for correct oil level.
- To change engine oil, see the Customer Responsibilities section of this manual.

### ADD GASOLINE

- Fill fuel tank. Use fresh, clean, regular unleaded gasoline with a minimum of 87 octane. (Use of leaded gasoline will increase carbon and lead oxide deposits and reduce valve life). Do not mix oil with gasoline. Purchase fuel in quantities that can be used within 30 days to ensure fuel freshness.

**IMPORTANT:** WHEN OPERATING IN TEMPERATURES BELOW 32° F. (0° C.), USE FRESH, CLEAN WINTER GRADE GASOLINE TO HELP INSURE GOOD COLD WEATHER STARTING.



### CAUTION

Experience indicates that alcohol blended fuels (called gasohol or using ethanol or methanol) can attract moisture which leads to separation and formation of acids during storage. Acidic gas can damage the fuel system of an engine while in storage. To avoid engine problems, the fuel system should be emptied before storage of 30 days or longer. Drain the gas tank, start the engine and let it run until the fuel lines and carburetor are empty. Use fresh fuel the next season. See Storage Instructions for additional information. Never use engine or carburetor cleaners in the fuel tank or permanent damage may occur.



### WARNING

Fill to bottom of filler neck. Do not over fill. Wipe off any spilled oil or fuel. Do not store, spill or use gasoline near an open flame.

## TO START ENGINE (See Fig. 3)

When starting the engine for the first time or if the engine has run out of fuel, it will take extra cranking time to move fuel from the tank to the engine.

- Be sure IZT (Integrated Zereturn Transaxle) bypass linkages are in the drive position.
- Sit on the seat in the operators position, release park brake lever.
- Check to be sure the PTO switch is disengaged.
- Move the throttle control to the choke position.
- For a warm engine start, the choke control may not be needed

---

## OPERATION

---

**NOTE:** Before starting, read the warm and cold starting procedures below.

- Insert key into the ignition and turn the key clockwise to “START” position and release the key as soon the engine starts. Do not run the starter continuously for more than 15 seconds per minute. If the engine does not start after several attempts, push the throttle control into the choke position, wait a few minutes and try again. If the engine still does not start, move the throttle control back into the fast position and retry.

**WARM WEATHER STARTING (50° F and above)**

- When the engine starts, slowly pull the throttle control back until the engine begins to run smoothly. If the engine starts to run roughly, press the throttle control back forward to choke the engine for a few seconds. Then continue to pull the throttle control back to the fast position.
- The PTO switch and ground drive can now be used. If the engine does not accept the load, restart the engine and allow it to warm up for one minute using the choke as described above.

**COLD WEATHER STARTING (50° F and below)**

- When the engine starts, slowly pull the throttle control back until the engine begins to run smoothly. Continue to pull back on the throttle control in small steps allowing the engine to accept small changes in speed and load, until the throttle control is completely in the fast position. If the engine starts to run roughly, press the throttle control back forward to choke the engine for a few seconds. Then continue to pull the throttle control back slowly to the fast position. This may require an engine warm up period from several seconds to several minutes, depending on the temperature.

### MOWING TIPS

- The cutting deck should be properly leveled for best mowing performance. See “TO LEVEL DECK” in the Service and Adjustment section of this manual.
- The left hand side of the deck should be used for trimming.
- Drive so that clippings are discharged onto the area that has been cut. Have the cut area to the right of the mower. This will result in more even distribution of clippings and a more uniform cut.
- If grass is extremely tall, it should be mowed twice to reduce load and possible fire hazard from dried clippings. Make first cut relatively high; second to desired height.
- Do not mow grass when it is wet. Wet grass will plug the deck and leave undesirable clumps. Allow grass to dry before mowing.
- **Always operate engine at full throttle when mowing** to assure better mowing performance and proper discharge of material. Regulate ground speed by going slow enough to allow proper deck cutting performance as well as the quality of cut desired. When operating attachments, select a ground speed that will suit the terrain and give best performance of the attachment being used.

# CUSTOMER RESPONSIBILITIES

MAINTENANCE SCHEDULE							
	Before each use	EVERY					Before Storage
		8 Hours	25 Hours	50 Hours	100 Hours	Season	
Check Brake Operation	<b>X</b>	<b>X</b>					
Check Tire Pressure	<b>X</b>	<b>X</b>					
Check Operator Presence and Interlock Systems	<b>X</b>						
Check for Loose Fasteners	<b>X</b>				<b>X</b> <sup>5</sup>		<b>X</b>
Sharpen/Replace mower Blades			<b>X</b> <sup>3</sup>				
Lubrication Chart			<b>X</b>				<b>X</b>
Check Battery Level			<b>X</b> <sup>4</sup>				
Clean Battery and Terminals			<b>X</b>				<b>X</b>
Check V-Belts					<b>X</b>		
Check Engine Oil Level	<b>X</b>	<b>X</b>					
Change Engine Oil (with oil filter)				<b>X</b> <sup>1, 2</sup>			<b>X</b>
Change Engine Oil (without oil filter)			<b>X</b> <sup>1, 2</sup>				<b>X</b>
Clean Air Filter			<b>X</b> <sup>2</sup>				
Clean Air Screen			<b>X</b> <sup>2</sup>				
Inspect Muffler/Spark Arrester				<b>X</b>			
Replace Oil Filter					<b>X</b> <sup>1, 2</sup>		
Clean Engine Cooling Fins					<b>X</b> <sup>2</sup>		
Replace Spark Plug					<b>X</b>	<b>X</b>	
Replace Air Filter Paper Cartridge					<b>X</b> <sup>2</sup>		
Replace Fuel Filter						<b>X</b>	

1 - change more often when operating under a heavy load or in high ambient temperatures.  
 2 - Service more often when operating in dirty or dusty

3 - Replace blades more often when mowing in sandy soil.  
 4 - Not required if equipped with maintenance-free battery.  
 5 - Tighten front axle pivot bolt to 35 ft./lbs. maximum. DO NOT overtighten.

## GENERAL RECOMMENDATIONS

The warranty on this mower does not cover items that have been subjected to operator abuse or negligence. To receive full value from the warranty, operator must maintain mower as instructed in this manual.

Some adjustments will need to be made periodically to properly maintain your mower.

All adjustments in the Service and Adjustments section of the this manual should be checked at least once each season.

- Once a year you should replace the spark plug, clean or replace air filter, and check blades and belts for wear. A new spark plug and clean air filter assure proper air-fuel mixture and help your engine run better and last longer.

## BEFORE EACH USE

- Check engine oil level.
- Check brake operation.
- Check tire pressure.
- Check operator presence and interlock systems for proper operation.
- Check for loose fasteners.

# CUSTOMER RESPONSIBILITIES

## LUBRICATION CHART

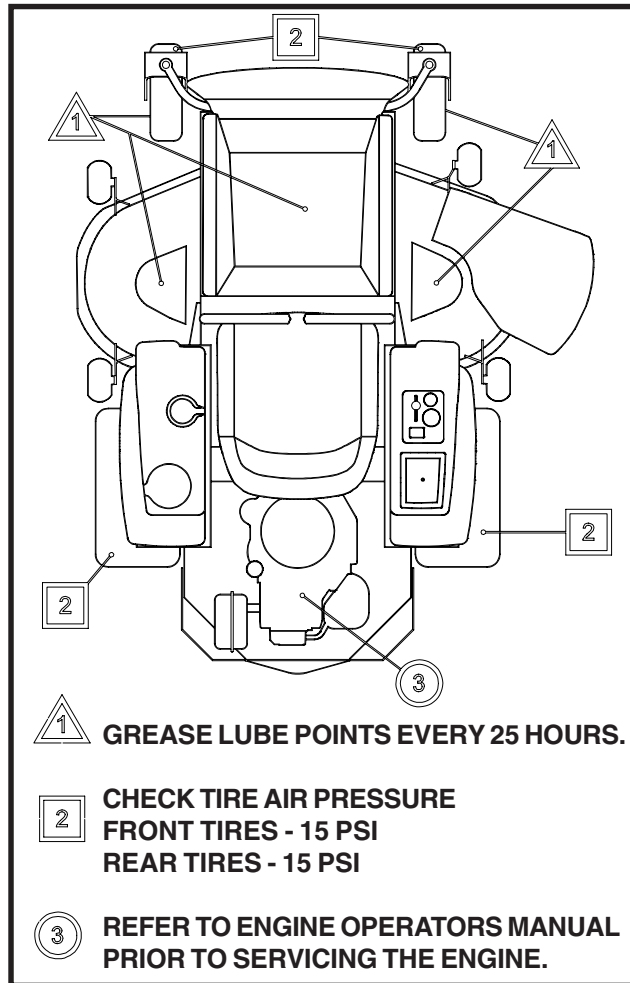

**IMPORTANT:** DO NOT OIL OR GREASE THE PIVOT POINTS WHICH HAVE SPECIAL NYLON BEARINGS. VISCOUS LUBRICANTS WILL ATTRACT DUST AND DIRT THAT WILL SHORTEN THE LIFE OF THE SELF-LUBRICATING BEARINGS. IF YOU FEEL THEY MUST BE LUBRICATED, USE ONLY A DRY, POWDERED GRAPHITE TYPE LUBRICANT SPARINGLY.

## TIRES

- Maintain proper air pressure in all tires (See "SPECIFICATIONS" section of this manual).
- Keep tires free of gasoline, oil, or insect control chemicals which can harm rubber.
- Avoid stumps, stones, deep ruts, sharp objects and other hazards that may cause tire damage.

**NOTE:** To seal tire punctures and prevent flat tires due to slow leaks, tire sealant may be purchased from your local parts dealer. Tire sealant also prevents tire dry rot and corrosion.

## OPERATOR PRESENCE SYSTEM

Be sure the operator presence and interlock systems are working properly. If your mower does not function as described, repair the problem immediately.

- The engine should not start unless the parking brake is engaged, the PTO switch is disengaged (pressed down), the operator is on the seat, and the control levers are rotated to the outside of the mower.
- When the engine is running, any attempt by the operator to leave the seat without first setting the park brake should shut off the engine.
- When the engine is running and the PTO switch is engaged, any attempt by the operator to leave the seat without first disengaging the PTO switch, should shut off the engine.
- When the engine is running and the control levers are rotated in, any attempt by the operator to leave the seat without rotating the control levers out, should shut off the engine.
- The PTO switch should never engage without the operator on the seat.

## BLADE CARE

For best results, mower blades must be kept sharp. Replace bent or damage blades.

## BLADE REMOVAL (See Fig. 8)

**NOTE:** Protect your hands with gloves and/or wrap blade with heavy cloth.

- Remove blade bolt by turning counter-clockwise.
- Install new or resharpened blade with stamped "THIS SIDE UP" facing deck and cutter housing.

## CUSTOMER RESPONSIBILITIES

**IMPORTANT:** TO ENSURE PROPER ASSEMBLY, CENTER HOLE IN BLADE MUST ALIGN WITH STAR ON CUTTER HOUSING.

- Install and tighten blade bolt securely (45-55 ft./lbs. torque).

**IMPORTANT:** SPECIAL BLADE BOLT IS HEAT TREATED.

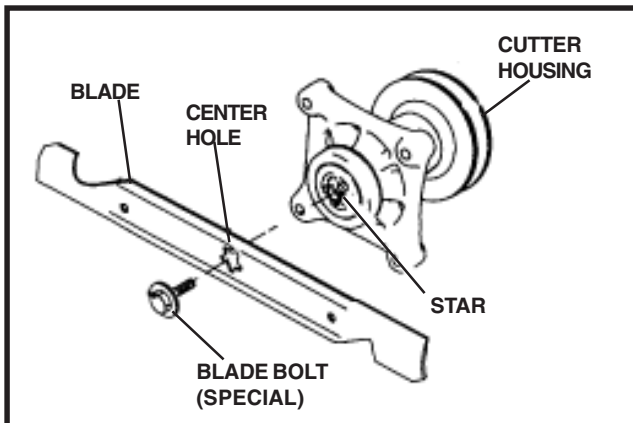

FIGURE 8

### TO SHARPEN BLADE (See Fig. 9)



#### WARNING

When it is necessary to raise the mower for any repair or service, use jackstands to provide adequate support. DO NOT rely on hydraulic or mechanical jacks

Care should be taken to keep the blade balanced. An unbalanced blade will cause excessive vibration and eventual damage to mower and engine.

- The blade can be sharpened with a file or on a grinding wheel. Do not attempt to sharpen while on the mower.
- To check blade balance, you will need a 5/8" diameter steel bolt, pin, or a cone balancer. (When using a cone balancer, follow the instructions supplied with balancer.)

**NOTE:** Do not use a nail for balancing the blade. The lobes of the center hole may appear to be centered, but are not.

- Slide blade on to an un-threaded portion of the steel bolt or pin and hold the bolt or pin parallel with the ground. If the blade is balanced, it should remain in a horizontal position. If either end of the blade moves downward, sharpen the heavy end until the blade is balanced.

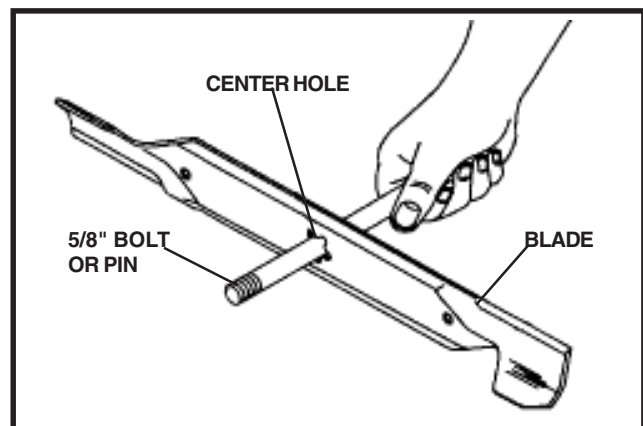

FIGURE 9

### BATTERY

Your mower is equipped with a maintenance free battery and does not need servicing. However, periodic charging of the battery with an automotive type battery charger will extend its life.

- Keep battery and terminals clean.
- Keep battery bolts tight.
- Recharge at 6-10 amperes for 1 hour.



---

## CUSTOMER RESPONSIBILITIES

---

**NOTE:** Do not attempt to open or remove caps or covers. Adding or checking level of electrolyte is not necessary.

### TO CLEAN BATTERY AND TERMINALS

Corrosion and dirt on the battery and terminals can cause the battery to “leak” power.

- Remove terminal guard.
- Disconnect BLACK battery cable first, then the RED battery cable and remove the battery from the tractor.
- Rinse the battery with plain water and dry.
- Clean terminals and battery cable ends with wire brush until shiny.
- Coat terminals with grease or petroleum jelly
- Reinstall battery (See “REPLACING BATTERY” in the SERVICE AND ADJUSTMENT section of this manual).

### V-BELTS

Check V-belts for deterioration and wear after 100 hours of operation and replace if necessary. The Belts are not adjustable. Replace belts if they begin to slip from wear.

### ENGINE

#### LUBRICATION

Refer to you Engine Owners Manual

TO CHANGE ENGINE OIL (See Fig. 10 [Kawasaki]).

- Be sure the mower is on a level surface.
- Oil will drain more freely when warm.
- Place a suitable container under the left rear corner of the rear of the mower.
- Remove oil dipstick. Be careful not to allow dirt to enter the engine when changing oil.
- Using the clear plastic tube included with you mower, place it over the end of the drain valve located on the left side of your engine.

- Place the other end of the tube thru the 2" diameter hole on the left side of the rear deck.
- Be sure container is located under this area of the mower.
- Using a 10 mm wrench, turn the hex head on the oil valve counter clockwise until the oil is draining out of the tube.

After the oil has drained, turn the hex head clockwise until it is tight (do not over tighten).

- Remove the plastic tube from the valve, clean excess oil off of tube and store in a safe place for the next use.
- Refill engine with oil through the oil dipstick tube. Pour slowly. Do not overfill.
- See Engine Owners Manual for type and capacity of the oil.

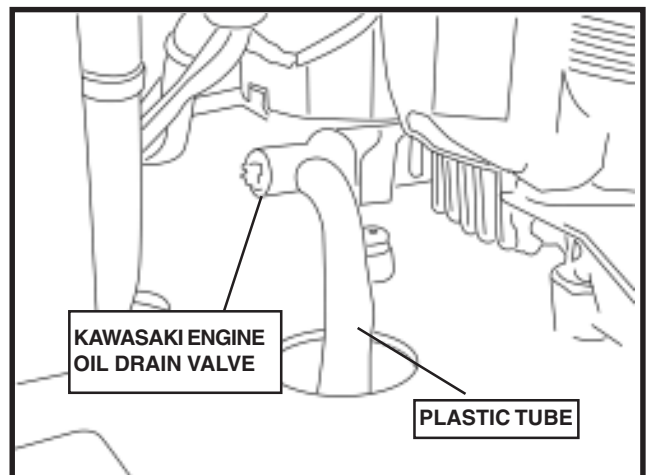

FIGURE 10

CZ-13

#### CLEAN AIR SCREEN

Air screen must be kept free of dirt and chaff to prevent engine damage from overheating. Refer to your engine manual for the proper cleaning procedure.

#### CLEAN AIR INTAKE/COOLING AREAS

To insure proper cooling, make sure the grass screen, cooling fins, and other external surfaces of the engine are kept clean at all times.

## CUSTOMER RESPONSIBILITIES

Every 100 hours of operation (more often under extremely dusty, dirty conditions), remove the blower housing and other cooling shrouds. Clean the cooling fins and external surfaces as necessary. Make sure the cooling shrouds are reinstalled.

**NOTE:** Operating the engine with a blocked grass screen, dirty or plugged cooling fins, and/or cooling shrouds removed will cause engine damage due to overheating.

### AIR FILTER

Your engine will not run properly using a dirty air filter. Service air cleaner more often under dusty conditions. See Engine Manual.

### ENGINE OIL FILTER

Replace the engine oil filter every season or every other oil change if the mower is used more than 100 hours in one year.

### SPARK PLUGS

Replace spark plugs at the beginning of each mowing season or after every 100 hours of operation, whichever occurs first. For spark plug type and gap setting refer to your ENGINE OWNER'S MANUAL.

### IN-LINE FUEL FILTER (See Figs. 11 and 12)

The fuel filter should be replaced once each season. If the fuel filter becomes clogged, obstructing fuel flow to carburetor, replacement is required.

- First turn off the fuel valve that is located under the fuel tank of you mower.
- With the engine cool, remove the filter and plug fuel line sections.
- Place new filter in position in fuel line with arrow pointing toward the carburetor.
- Be sure there are no fuel leaks and clamps are secure and properly positioned.
- Immediately wipe up any spilled gasoline.

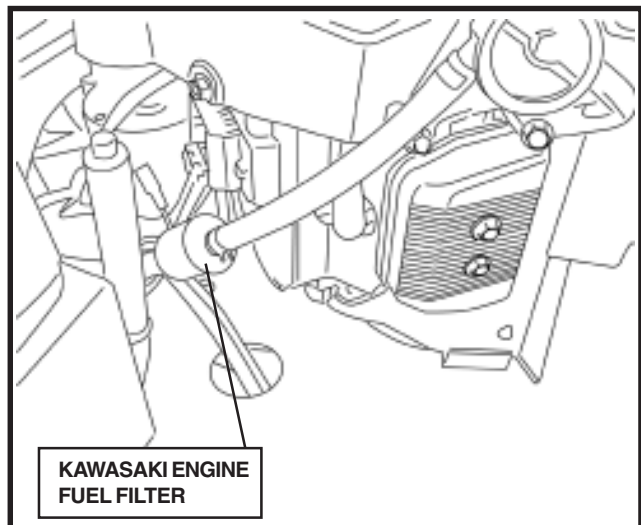

FIGURE 11

CZ-14

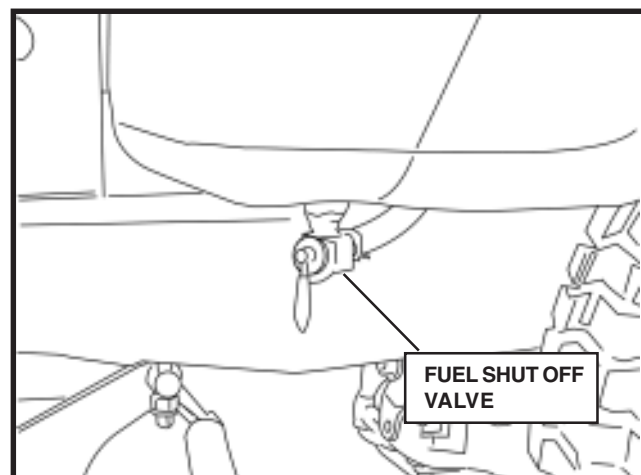

FIGURE 12

CZ-15

### CLEANING

- Clean engine, battery, seat, finish, etc. of all foreign matter.
- Keep finished surfaces and wheels free of all gasoline, oil, etc.
- Protect painted surfaces with automotive type wax.

We do not recommend using a garden hose to clean your mower unless the electrical system, muffler, air filter and carburetor are covered to keep water out. Water in the engine can shorten the engine life.

# SERVICE AND ADJUSTMENT



## WARNING

### BEFORE PERFORMING ANY SERVICE OR ADJUSTMENTS:

- Set park brake to engaged position.
- Place PTO switch in the disengaged position (pressed down).
- Turn ignition key "OFF" and remove the key.
- Make sure the blades and all moving parts have completely stopped.
- Disconnect spark plug wire from spark plug and place the wire where it cannot come in contact with the plug.

the front and rear lift linkages (be sure to tighten equal amounts).

- To lower one side of the deck, reverse previous step.
- Recheck measurements after adjustment.

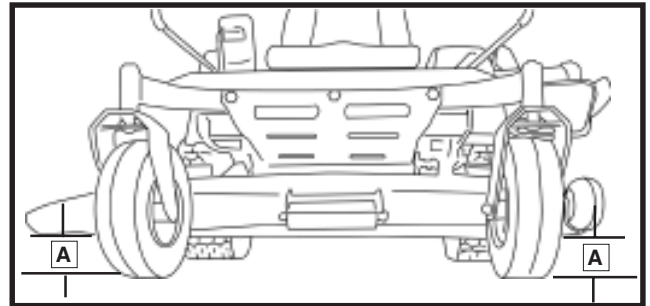

FIGURE 13

CZ-16

## MOWER

### TO LEVEL DECK

Adjust the deck while the mower is on a level surface. Make sure the tires are inflated to the correct pressure (see "SPECIFICATIONS" section in this manual). If tires are under or over inflated, you can not properly adjust your deck.

**NOTE:** It may be easier to adjust the front lift linkages by removing the floor pan before any adjustments are made

### SIDE-TO-SIDE ADJUSTMENT (See Figs. 13 and 14)

- Raise the deck into the highest cutting position (4 1/2")
- Measure height from the bottom edge of the deck to the ground at both front corners. Distance "A" at both corners should be the same.
- If adjustment is necessary, make adjustment to one side the deck only
- To raise one side of the deck, using a 9/16" wrench, tighten the hex nuts on both

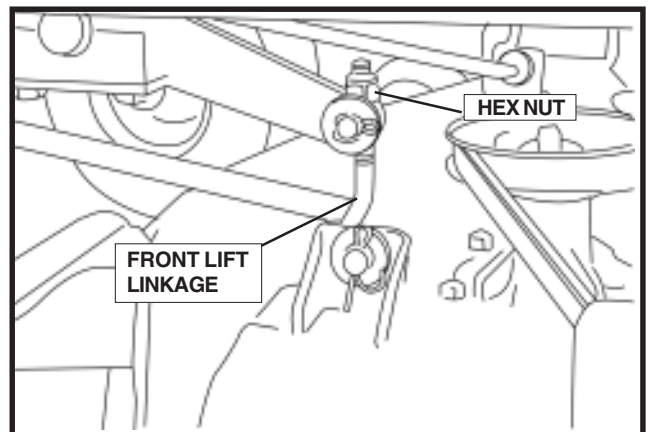

FIGURE 14

CZ-17

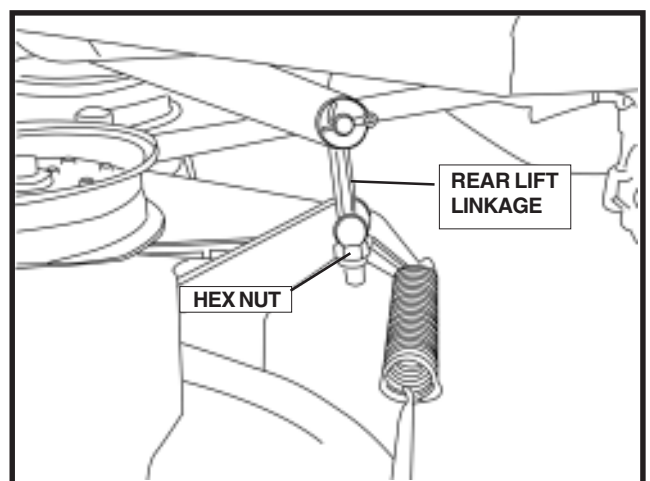

FIGURE 14A

CZ-18

## SERVICE AND ADJUSTMENT

FRONT-TO-BACK ADJUSTMENT (See Fig. 15).

**IMPORTANT:** DECK MUST BE LEVEL SIDE-TO-SIDE. IF THE FOLLOWING FRONT-TO-BACK ADJUSTMENT IS NECESSARY, BE SURE TO ADJUST BOTH FRONT OR BOTH REAR LINKAGES EQUALLY SO THE DECK WILL STAY LEVEL.

To obtain the best cutting performance, the deck should be adjusted so the front tip of the blades are approximately 1/8" to 1/4" lower than the rear tip. If the front tip is higher, this will create a poor quality of cut.

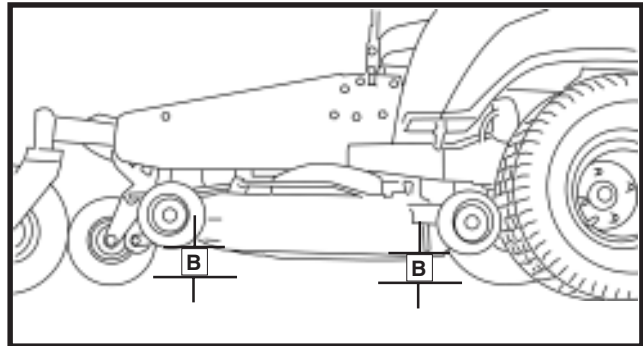

FIGURE 15

CZ-19



### WARNING

**Blades are sharp. Protect your hands with gloves and/or wrap blades with a heavy cloth when handling.**

Check adjustment on the right side of the mower. Position any blade so that the tip is pointing straight forward. Measure distance "B" at the front and rear tip of the blade.

- Before making any necessary adjustments, check to make sure that the deck is level side-to-side.
- With the deck in the highest cutting position, (4 1/2") measure the front tip of the blade to see if the deck is higher or lower than 4 1/2".
- To lower the front tip of the blade, using a 9/16" wrench, loosen the hex nuts that are on the front lift linkages (be sure to loosen equal amounts).
- When distance "B" is 1/8" to 1/4" lower at the front than rear the adjustment is done.
- Reverse above step to raise the deck.

## TO REPLACE DECK BELT

DECK BELT REMOVAL (See Fig. 16 and 17)

- Park on a level surface. Apply park brake.
- Lower the deck into the lowest cutting position
- Disengage the tension relief lever from the lock bracket.



### WARNING

**Lever is spring loaded. Have a tight grip on the lever and release slowly.**

- Remove screws from both the left and right belt shields, and remove shields.
- Remove any dirt or grass that may have accumulated around the cutter housings and entire deck surface.
- Carefully roll the belt over the top of the cutter housing pulleys.
- Remove the belt from around the electric clutch on the engine shaft.
- The belt can now be removed.

# SERVICE AND ADJUSTMENT

DECK BELT INSTALLATION (See Figs. 16 and 17)

**NOTE:** For ease in installing the deck belt, refer to the routing decal on the front edge of the deck.

- Wrap the deck belt around the electric clutch that is located on the engine shaft.
- Push the rest of the belt through the IZT(Integrated Zereturn Transaxle) support and up onto the deck.
- Starting on the right hand side of the deck, wrap the belt around the large right side idler, right cutter housing pulley, small center idler, center pulley, left side pulley and then around the large left side idler.
- The belt will be loose at this point.
- Tightly secure the belt tension rod and reengage it in the lock bracket.

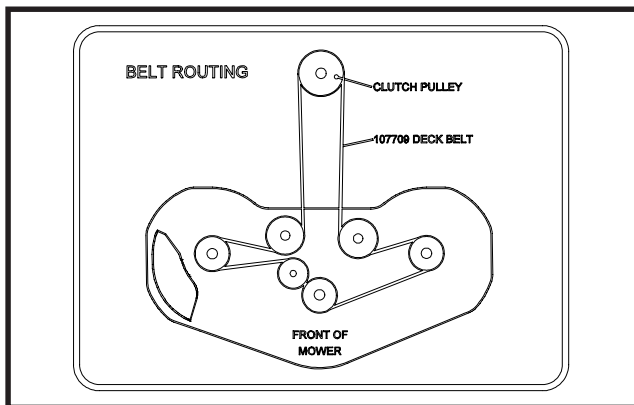

FIGURE 16

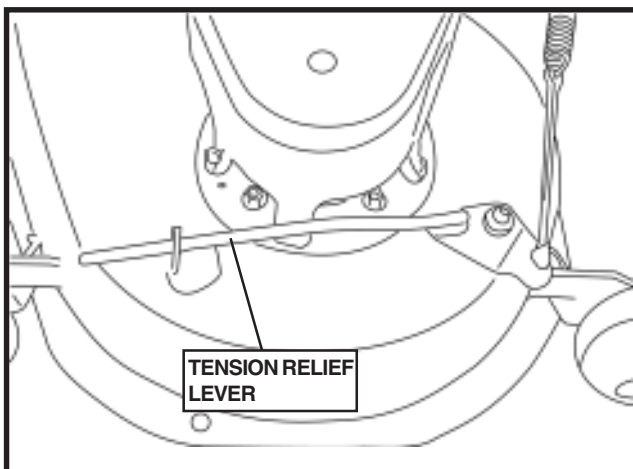

FIGURE 16A

CZ-20

## TO REPLACE IZT (Integrated Zereturn Transaxle) BELT (See Fig. 17)

Park the mower on a level surface. Engage the park brake.

### IZT BELT REMOVAL

**NOTE:** Be careful not to damage the fan blades on the IZT's as this can affect cooling or damage the IZT's.

- Remove the deck belt (see "TO REPLACE DECK BELT" in this section of the manual).
- Create slack in the belt by removing the spring on the pump idler arm.
- The belt should now be able to be removed from the engine pulley and IZT pulleys.

### BELT INSTALLATION

- Wrap the IZT belt around the IZT pulleys
- Route the belt around the inside of the idler pulley.
- Now you can wrap the belt around the engine pulley.
- Reattach the spring on the pump idler arm.
- Reinstall the deck belt onto the electric clutch belt (see "TO REPLACE DECK BELT" in this section of the manual).

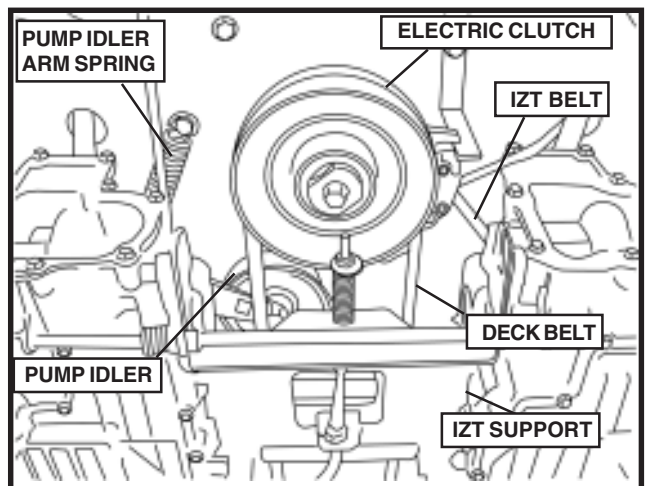

FIGURE 17

CZ-21

---

## SERVICE AND ADJUSTMENT

---

### TO ADJUST THE SEAT (See Fig. 1)

- Move the control levers into the neutral position and rotate to the outside of the machine.
- Lift up on the back of the seat and rotate it forward.
- Loosen the three prong knobs on the bottom of the seat and move the seat to the desired position.
- Tighten the three prong knobs and rotate seat back to the operating position.

### TO ADJUST CONTROL LEVERS (See Fig. 2)

Sitting on the seat, in the operators position, press both control levers forward. If both control levers line up with each other, then no adjustment is needed. If they do not line up, follow instructions below.

- Identify which control lever moves further forward.
- Using a 9/16" wrench, slightly loosen the bottom hex bolt (about 1/2 turn) on the opposite control lever.
- Move both control levers to the front again and apply more pressure to the control lever that you loosened to bring the two control levers in line with each other.
- Tighten hex bolts.

### TO REMOVE WHEELS FOR REPAIR

#### FRONT CASTER TIRES

- Park mower on a level surface and apply park brake.
- Jack up the front end of the mower.
- Using a 3/4" wrench and/or socket w/ drive ratchet, remove hex nut and hex bolt from the caster fork.
- Remove the tire from the fork.

- Remove the spacer from the inside of the caster rim.
- Repair tire
- Reassemble in the reverse order of the previous steps.

#### REAR TIRES

**IMPORTANT:** Block front tires to prevent the mower from rolling.

- Park mower on a level surface and apply park brake.
- Jack up the rear end of the mower on the side of the damaged tire.
- Remove 4 lug nuts to allow wheel removal
- Repair tire.
- Reassemble in reverse order of previous steps

**NOTE:** To seal tire punctures and prevent flat tires due to slow leaks, tire sealant may be purchased from your local parts dealer. Tire sealer also prevents tire dry rot and corrosion.

### TO START AN ENGINE WITH A WEAK BATTERY



#### WARNING

**Lead-acid batteries generate explosive gases. Keep sparks, flame and smoking materials away from batteries. Always wear eye protection when around batteries.**

If your battery is too weak to start the engine, it should be recharged. (See "BATTERY" in the Customer Responsibilities section of this manual).

If "jumper cables" are used for emergency starting, follow this procedure:

**IMPORTANT:** YOUR MOWER IS EQUIPPED WITH A 12-VOLT NEGATIVE GROUNDED SYSTEM. THE OTHER VEHICLE MUST ALSO BE A 12-VOLT NEGATIVE GROUNDED SYSTEM. DO NOT USE YOUR MOWER BATTERY TO START OTHER VEHICLES.

# SERVICE AND ADJUSTMENT

## TO ATTACH JUMPER CABLES

- Connect each end of the RED cable to the POSITIVE (+) terminal on each battery, taking care not to short against chassis.
- Connect one end of the BLACK cable to the NEGATIVE (-) terminal of the fully charged battery.
- Connect the other end of the BLACK cable to a good CHASSIS GROUND, away from the fuel tank and battery.

## TO REMOVE CABLES, REVERSE ORDER

- BLACK cable first from chassis and then from the fully charged battery.
- RED cable last from both batteries.

## REPLACING BATTERY (See Fig. 18)



### WARNING

**Do not short battery terminals by allowing a wrench or any other object to contact both terminals at the same time. Before connecting battery, remove metal bracelets, wristwatch bands, rings, etc.**

**Positive terminal must be connected first to prevent sparking from accidental grounding.**

- Lift Seat and rotate forward.
- Open terminal access doors.
- Using two 1/2" wrenches disconnect BLACK battery cable then RED battery cable.
- Using 7/16" wrench, remove terminal guard.
- Carefully remove the battery from the mower.
- Install new battery with terminals in the same position as the old battery.
- Reinstall terminal guard
- First connect RED battery cable to positive (+) battery terminal with hex bolt and hex nut.

- Connect BLACK grounding cable to negative (-) battery terminal with remaining hex bolt and hex nut.
- Tighten securely.
- Close terminal access doors.
- Lower seat.

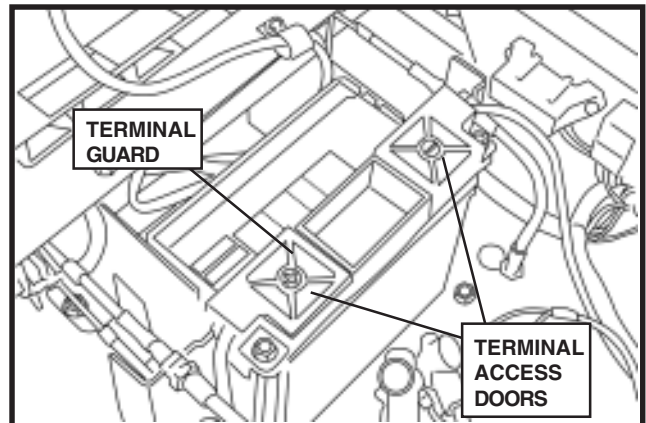

FIGURE 18

CZ-22

## TO ADJUST PARK BRAKE

Before making any adjustments:

**NOTE:** Make sure the brake arm is engaged into brake sprocket on both sides. You can push the mower to make it engage into the sprocket. See Fig. 19.

- With the park brake in the on position, the compression spring should be 2" from the "U" shaped brake arm to the washer. See Fig. 19. If not, use two wrenches, one to hold the bolt and one to turn the nut to attain the 2".

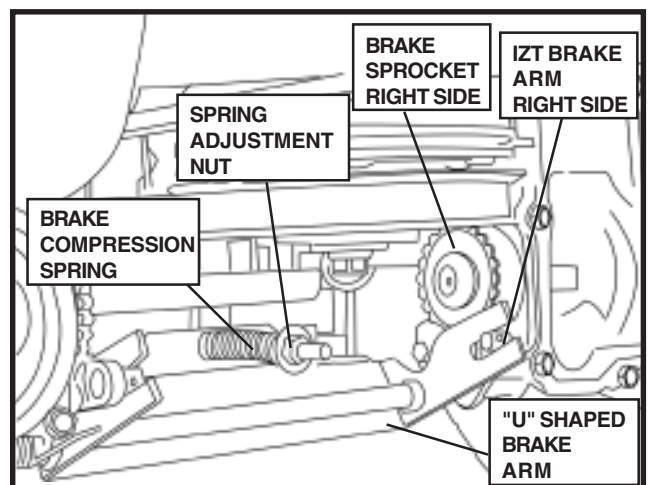
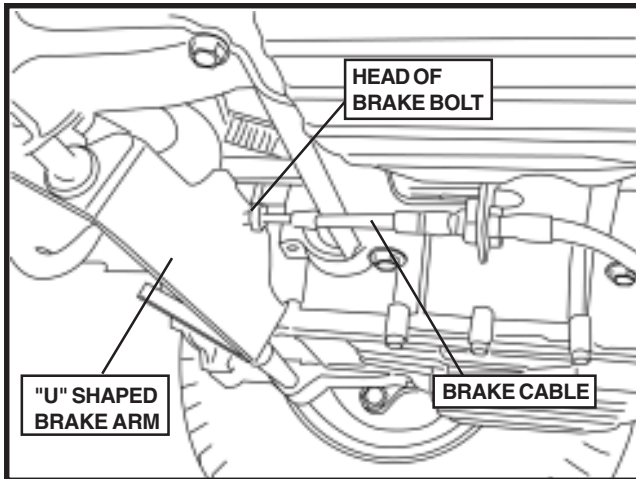

FIGURE 19

CZ-23

## SERVICE AND ADJUSTMENT

- 1/4" gap should exist between the "U" shaped brake arm and the inside of the brake bolt head. See Fig. 20.



CZ-24

FIGURE 20

- The 1/4" gap can be adjusted with the brake swivel (located under the seat), pull pin and rotate swivel one turn counter-clockwise to increase gap or clockwise to decrease the gap until the 1/4" gap is attained. See Fig. 21.

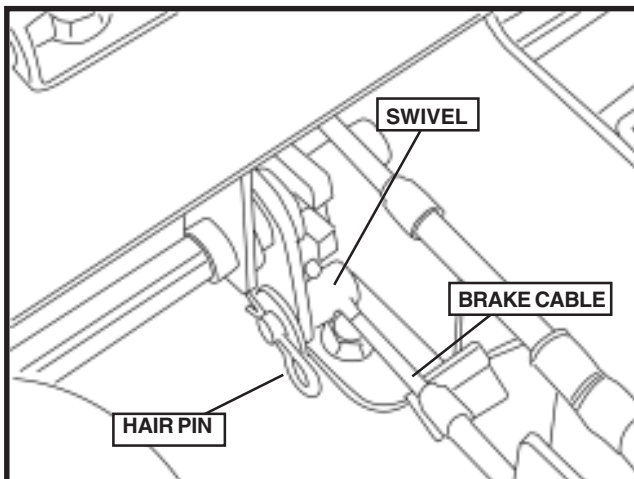

CZ-25

FIGURE 21

NOTE: After making any adjustments, check to make sure the brake disengages the brake sprockets, when the brake is in the "OFF" position.

## TRACKING ADJUSTMENT

**IMPORTANT:** DO NOT adjust the drive cables in an attempt to resolve tracking issues. Cables are set at the factory and should only be adjusted by authorized service retailers.

If the mower is not tracking straight, check the air pressure in both rear tires. Recommended air pressure is 15 psi. If the unit will not track straight, follow the steps below. Tracking must be checked on a flat and level concrete or blacktop surface.

- **Mower is tracking to the right.** Increase the air pressure 2-3 psi in the right rear tire or decrease the air pressure 2/3 psi in the left rear tire.
- **Mower is tracking to the left.** Increase the air pressure 2-3 psi in the left rear tire or decrease the air pressure 2/3 psi in the right rear tire.

Recheck tracking and keep making adjustments with the tire pressure until the unit tracks straight. DO NOT exceed maximum recommended tire pressure 24 psi.

Record the tire pressure for future reference.



---

# STORAGE

---

Immediately prepare your mower for storage at the end of the season or if the mower will not be used for 30 days or more.



## WARNING

**Never store the mower with gasoline in the tank inside a building where fumes may reach an open flame or spark. Allow the engine to cool before storing in any enclosure.**

## MOWER

When mower is to be stored for a period of time, clean it thoroughly, remove all dirt, grease, leaves, etc. Store in a clean, dry area.

- Clean entire mower (See "CLEANING" in the Customer Responsibilities section of this manual).
- Inspect and replace belts, if necessary (See belt replacement instructions in the Service and Adjustments section of this manual).
- Lubricate as shown in the Customer Responsibilities section of this manual.
- Be sure that all nuts, bolts and screws are securely fastened. Inspect moving parts for damage, breakage and wear. Replace if necessary.
- Touch up all rusted or chipped paint surfaces; sand lightly before painting.

## BATTERY

- Fully charge the battery for storage.
- After a period of time in storage, battery may require recharging.
- To help prevent corrosion and power leakage during long periods of storage, battery cables should be disconnected and battery cleaned thoroughly (see "TO CLEAN BATTERY AND TERMINALS" in the Customer Responsibilities section of this manual).

- After cleaning, leave cables disconnected and place cables where they cannot come in contact with battery terminals.
- If battery is removed from mower for storage, do not store battery directly on concrete or damp surfaces.

## ENGINE

### FUEL SYSTEM

IT IS IMPORTANT TO PREVENT GUM DEPOSITS FROM FORMING IN ESSENTIAL FUEL SYSTEM PARTS SUCH AS CARBURETOR, FUEL FILTER, FUEL HOSE, OR TANK DURING STORAGE. ALSO, EXPERIENCE INDICATES THAT ALCOHOL BLENDED FUELS (CALLED GASOHOL OR USING ETHANOL OR METHANOL) CAN ATTRACT MOISTURE WHICH LEADS TO SEPARATION AND FORMATION OF ACIDS DURING STORAGE. ACIDIC GAS CAN DAMAGE THE FUEL SYSTEM OF AN ENGINE WHILE IN STORAGE.

- Drain the fuel tank.
- Start the engine and let it run until the fuel lines and carburetor are empty.
- Never use engine or carburetor cleaner products in the fuel tank or permanent damage may occur.
- Use fresh fuel next season.

**NOTE:** Fuel stabilizer is an acceptable alternative in minimizing the formation of fuel gum deposits during storage. Add stabilizer to gasoline in fuel tank or storage container. Always follow the mix ratio found on stabilizer container. Run engine at least 10 minutes after adding stabilizer to allow the stabilizer to reach the carburetor. Do not drain the gas tank and carburetor if using fuel stabilizer.

### ENGINE OIL

Drain oil (with engine warm) and replace with clean engine oil. (See "ENGINE" in the Customer Responsibilities section of this manual).

---

## STORAGE

---

### CYLINDER(S)

- Remove spark plug(s).
- Pour one ounce of oil through spark plug hole(s) into cylinder(s).
- Install plugs.
- Turn ignition key to "START" position for a few seconds to distribute oil.
- Replace with new spark plug(s).

### OTHER

- Do not store gasoline from one season to another.
- Replace your gasoline can if your can starts to rust. Rust and/or dirt in your gasoline will cause problems.
- If possible, store your mower indoors and cover it to give protection from dust and dirt.
- Cover your mower with a suitable protective cover that does not retain moisture. Do not use plastic. Plastic cannot breathe which allows condensation to form and will cause your mower to rust.

**IMPORTANT: NEVER COVER MOWER WHILE ENGINE AND EXHAUST AREAS ARE STILL WARM.**

# TROUBLESHOOTING POINTS

PROBLEM	CAUSE	CORRECTION
<b>Will not start</b>	<ol style="list-style-type: none"> <li>1. Out of fuel.</li> <li>2. Engine not "CHOKED" properly.</li> <li>3. Engine flooded.</li> <li>4. Bad spark plug.</li> <li>5. Dirty air filter.</li> <li>6. Dirty fuel filter.</li> <li>7. Water in fuel.</li>   <li>8. Loose or damaged wiring.</li> <li>9. Carburetor out of adjustment.</li> <li>10. Engine valves out of adjustment.</li> <li>11. Extreme cold conditions.</li> </ol>	<ol style="list-style-type: none"> <li>1. Fill fuel tank.</li> <li>2. See "TO START ENGINE" in Operation section.</li> <li>3. Wait several minutes before attempting to start.</li> <li>4. Replace spark plug.</li> <li>5. Clean/replace air filter.</li> <li>6. Replace fuel filter.</li> <li>7. Drain fuel tank and carburetor, refill tank with fresh gasoline and replace fuel filter.</li> <li>8. Check all wiring.</li> <li>9. See Engine Manual.</li> <li>10. Contact an authorized service center/department.</li> <li>11. See "To start engine" in operation section.</li> </ol>
<b>Hard to start</b>	<ol style="list-style-type: none"> <li>1. Dirty air filter.</li> <li>2. Bad spark plug.</li> <li>3. Weak or dead battery.</li> <li>4. Dirty fuel filter.</li> <li>5. Stale or dirty fuel.</li> <li>6. Loose or damaged wiring.</li> <li>7. Carburetor out of adjustment.</li> <li>8. Engine valves out of adjustment.</li> </ol>	<ol style="list-style-type: none"> <li>1. Clean/replace air filter.</li> <li>2. Replace spark plug.</li> <li>3. Recharge or replace battery.</li> <li>4. Replace fuel filter.</li> <li>5. Drain fuel tank and refill with fresh gasoline.</li> <li>6. Check all wiring.</li> <li>7. See Engine Manual.</li> <li>8. Contact an authorized service center/department.</li> </ol>
<b>Engine will not turn over</b>	<ol style="list-style-type: none"> <li>1. Brake pedal not depressed.</li> <li>2. Attachment clutch is engaged.</li> <li>3. Weak or dead battery.</li> <li>4. Blown fuse.</li> <li>5. Corroded battery terminals.</li> <li>6. Loose or damaged wiring.</li> <li>7. Faulty ignition switch.</li> <li>8. Faulty solenoid or starter.</li> <li>9. Faulty operator presence switch(es).</li> </ol>	<ol style="list-style-type: none"> <li>1. Depress brake pedal.</li> <li>2. Disengage attachment clutch.</li> <li>3. Recharge or replace battery.</li> <li>4. Replace fuse.</li> <li>5. Clean battery terminals.</li> <li>6. Check all wiring.</li> <li>7. Check/replace ignition switch.</li> <li>8. Check/replace solenoid or starter.</li> <li>9. Contact an authorized service center/department.</li> </ol>
<b>Engine clicks but will not start</b>	<ol style="list-style-type: none"> <li>1. Weak or dead battery.</li> <li>2. Corroded battery terminals.</li> <li>3. Loose or damaged wiring.</li> <li>4. Faulty solenoid or starter.</li> </ol>	<ol style="list-style-type: none"> <li>1. Recharge or replace battery.</li> <li>2. Clean battery terminals.</li> <li>3. Check all wiring.</li> <li>4. Check/replace solenoid or starter.</li> </ol>
<b>Loss of power</b>	<ol style="list-style-type: none"> <li>1. Cutting too much grass/too fast.</li> <li>2. Throttle in "CHOKE" position.</li> <li>3. Buildup of grass, leaves and trash under deck.</li> <li>4. Dirty air filter.</li> <li>5. Low oil level/dirty oil.</li> <li>6. Faulty spark plug.</li> <li>7. Dirty fuel filter.</li> <li>8. Stale or dirty fuel.</li> <li>9. Water in fuel.</li>   <li>10. Spark plug wire loose.</li> <li>11. Dirty engine air screen/fins.</li> <li>12. Dirty/clogged muffler.</li> <li>13. Loose or damaged wiring.</li> <li>14. Carburetor out of adjustment.</li> <li>15. Engine valves out of adjustment.</li> </ol>	<ol style="list-style-type: none"> <li>1. Set in "Higher Cut" position/reduce speed.</li> <li>2. Adjust throttle control.</li> <li>3. Clean underside of mower housing.</li> <li>4. Clean/replace air filter.</li> <li>5. Check oil level/change oil.</li> <li>6. Clean and re-gap or change spark plug.</li> <li>7. Replace fuel filter.</li> <li>8. Drain fuel tank and refill with fresh gasoline.</li> <li>9. Drain fuel tank and carburetor, refill tank with fresh gasoline and replace fuel filter.</li> <li>10. Connect and tighten spark plug wire.</li> <li>11. Clean engine air screen/fins.</li> <li>12. Clean/replace muffler.</li> <li>13. Check all wiring.</li> <li>14. See Engine Manual.</li> <li>15. Contact an authorized service center/department.</li> </ol>
<b>Excessive vibration</b>	<ol style="list-style-type: none"> <li>1. Worn, bent or loose blade.</li> <li>2. Bent blade mandrel.</li> <li>3. Loose/damaged part(s).</li> </ol>	<ol style="list-style-type: none"> <li>1. Replace blade. Tighten blade bolt.</li> <li>2. Replace blade mandrel.</li> <li>3. Tighten loose part(s). Replace damaged parts.</li> </ol>

# TROUBLESHOOTING POINTS

PROBLEM	CAUSE	CORRECTION
<b>Engine continues to run when operator leaves seat with attachment</b>	<ol style="list-style-type: none"> <li>1. Faulty operator-safety presence control system.</li> </ol>	<ol style="list-style-type: none"> <li>1. Check wiring, switches and connections. If not corrected, contact an authorized service center/department.</li> </ol>
<b>Poor cut - uneven</b>	<ol style="list-style-type: none"> <li>1. Worn, bent or loose blade.</li> <li>2. Mower deck not level.</li> <li>3. Buildup of grass, leaves, and trash under mower.</li> <li>4. Bent cutter housing.</li> <li>5. Clogged mower deck vent holes from buildup of grass, leaves, and trash around cutter housing.</li> </ol>	<ol style="list-style-type: none"> <li>1. Replace blade. Tighten blade bolt.</li> <li>2. Level mower deck.</li> <li>3. Clean underside of mower housing.</li> <li>4. Replace cutter housing.</li> <li>5. Clean around cutter housing to open vent holes.</li> </ol>
<b>Mower blades will not rotate</b>	<ol style="list-style-type: none"> <li>1. Obstruction in clutch mechanism.</li> <li>2. Worn/damaged mower drive belt.</li> <li>3. Frozen idler pulley.</li> <li>4. Frozen cutter housing.</li> </ol>	<ol style="list-style-type: none"> <li>1. Remove obstruction.</li> <li>2. Replace mower drive belt.</li> <li>3. Replace idler pulley.</li> <li>4. Replace cutter housing.</li> </ol>
<b>Poor grass discharge</b>	<ol style="list-style-type: none"> <li>1. Engine speed too slow.</li> <li>2. Travel speed too fast.</li> <li>3. Wet grass</li> <li>4. Mower deck not level.</li> <li>5. Low/uneven tire air pressure.</li> <li>6. Worn, bent or loose blade.</li> <li>7. Buildup of grass, leaves and trash under mower.</li> <li>8. Mower drive belt worn.</li> <li>9. Blades improperly installed.</li> <li>10. Improper blades used.</li> <li>11. Clogged mower deck vent holes from buildup of grass, leaves and trash around cutter housing.</li> </ol>	<ol style="list-style-type: none"> <li>1. Place throttle control in "FAST" position.</li> <li>2. Shift to slower speed.</li> <li>3. Allow grass to dry before mowing.</li> <li>4. Level mower deck.</li> <li>5. Check tires for proper air pressure.</li> <li>6. Replace/sharpen blade. Tighten blade bolt.</li> <li>7. Clean underside of mower housing.</li> <li>8. Replace mower drive belt.</li> <li>9. Reinstall blades sharp edge down.</li> <li>10. Replace with blades listed in this manual.</li> <li>11. Clean around cutter housing to open bent holes.</li> </ol>
<b>Battery will not charge</b>	<ol style="list-style-type: none"> <li>1. Bad battery cell(s).</li> <li>2. Poor cable connections.</li> <li>3. Faulty regulator (if so equipped).</li> <li>4. Faulty alternator.</li> </ol>	<ol style="list-style-type: none"> <li>1. Replace battery.</li> <li>2. Check/clean all connections.</li> <li>3. Replace regulator.</li> <li>4. Replace alternator.</li> </ol>
<b>Loss of drive</b>	<ol style="list-style-type: none"> <li>1. IZT bypass linkages in bypass position.</li> <li>2. IZT belt worn, damaged, or broken.</li> </ol>	<ol style="list-style-type: none"> <li>1. Place IZT bypass linkages in drive in "engaged" position.</li> <li>2. Replace IZT belt.</li> </ol>
<b>Engine "backfires" when turning engine "OFF"</b>	<ol style="list-style-type: none"> <li>1. Engine throttle control not set at "SLOW" position for 30 seconds before stopping engine.</li> </ol>	<ol style="list-style-type: none"> <li>1. Move throttle control to "SLOW" position and allow to idle for 30 seconds before stopping engine.</li> </ol>

# WIRING SCHEMATIC

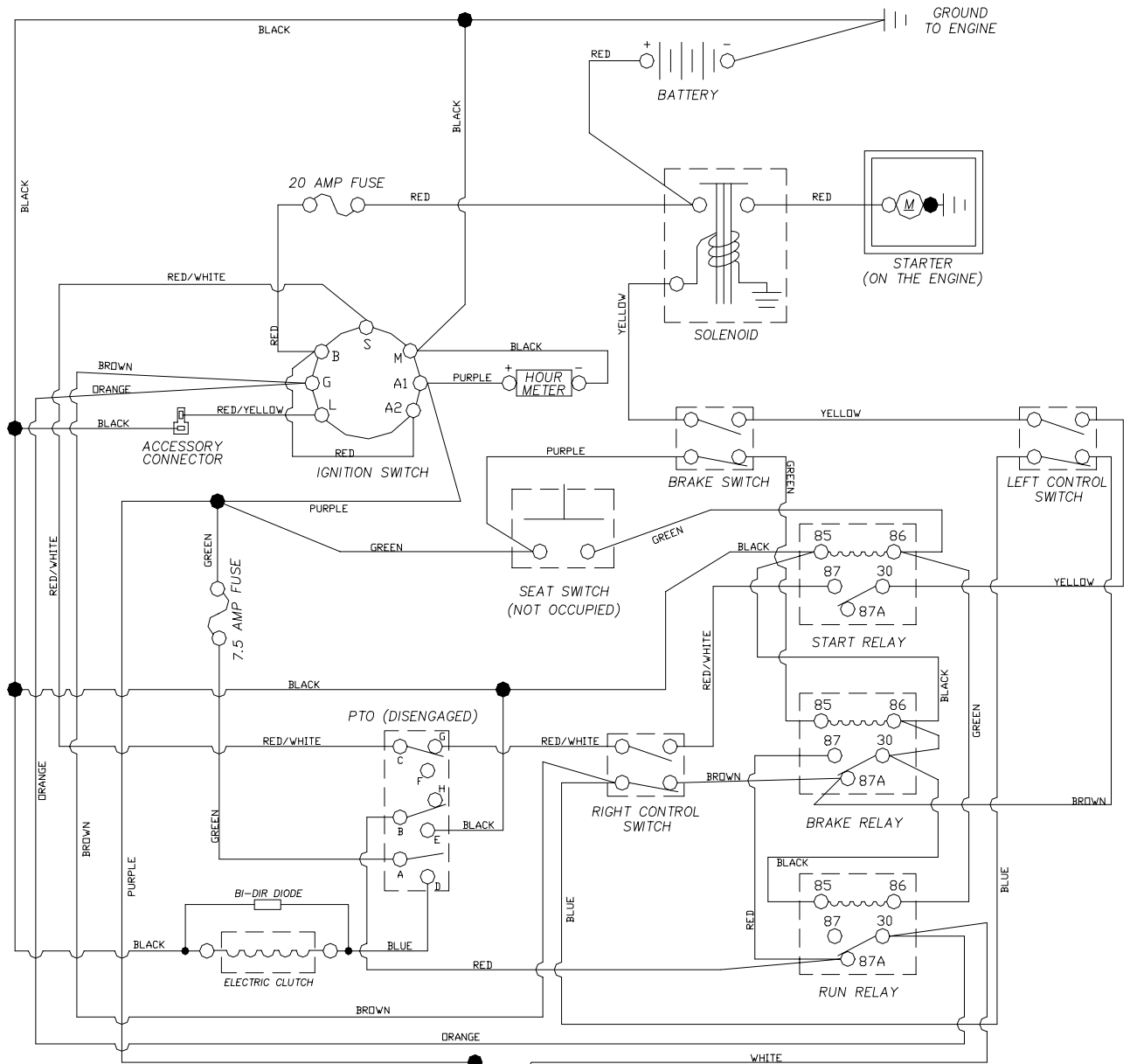

PTO SWITCH	
POSITION	CIRCUIT
OFF	C + G, B + H
ON	C + F, B + E, A + D

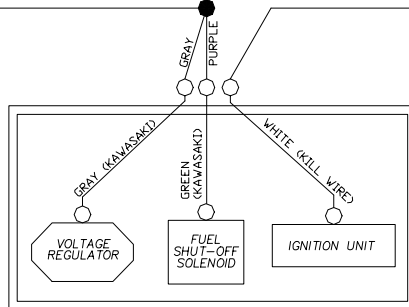
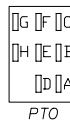

ENGINE  
(REFER TO ENGINE MANUAL FOR MORE DETAIL)

NON-REMOVABLE CONNECTIONS

REMOVABLE CONNECTIONS

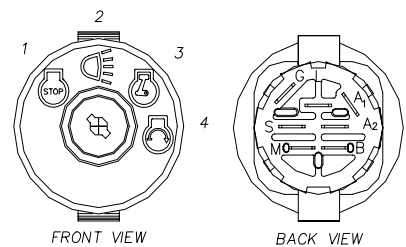
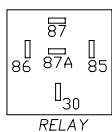

IGNITION SWITCH			
POSITION	FUNCTION	CONTACT 1	CONTACT 2
1	OFF	M+G+A <sub>1</sub>	NONE
2	ON+ASS.	B+A <sub>1</sub>	L+A <sub>2</sub>
3	ON	B+A <sub>1</sub>	NONE
4	START	B+S+A <sub>1</sub>	NONE





114 02 12-26



2003W33