



# 65RSW21HV

---

**Owner's Manual**



# SAFETY RULES



## Safe Operation Practices for Walk-Behind Mowers

**IMPORTANT:** THIS CUTTING MACHINE IS CAPABLE OF AMPUTATING HANDS AND FEET AND THROWING OBJECTS. FAILURE TO OBSERVE THE FOLLOWING SAFETY INSTRUCTIONS COULD RESULT IN SERIOUS INJURY OR DEATH.

### I. GENERAL OPERATION

- Read, understand, and follow all instructions on the machine and in the manual(s) before starting. Be thoroughly familiar with the controls and the proper use of the machine before starting.
- Do not put hands or feet near or under rotating parts. Keep clear of the discharge opening at all times.
- Only allow responsible individuals, who are familiar with the instructions, to operate the machine.
- Clear the area of objects such as rocks, toys, wire, bones, sticks, etc., which could be picked up and thrown by the blade.
- Be sure the area is clear of other people before mowing. Stop machine if anyone enters the area.
- Do not operate the mower when barefoot or wearing open sandals. Always wear substantial foot wear.
- Do not pull mower backwards unless absolutely necessary. Always look down and behind before and while moving backwards.
- Do not operate the mower without proper guards, plates, grass catcher or other safety protective devices in place.
- See manufacturer's instructions for proper operation and installation of accessories. Only use accessories approved by the manufacturer.
- Stop the blade(s) when crossing gravel drives, walks, or roads.
- Stop the engine (motor) whenever you leave the equipment, before cleaning the mower or unclogging the chute.
- Shut the engine (motor) off and wait until the blade comes to complete stop before removing grass catcher.
- Mow only in daylight or good artificial light.
- Do not operate the machine while under the influence of alcohol or drugs.
- Never operate machine in wet grass. Always be sure of your footing: keep a firm hold on the handle and walk; never run.
- Disengage the self-propelled mechanism or drive clutch on mowers so equipped before starting the engine (motor).
- If the equipment should start to vibrate abnormally, stop the engine (motor) and check immediately for the cause. Vibration is generally a warning of trouble.
- Always wear safety goggles or safety glasses with side shields when operating mower.

### II. SLOPE OPERATION

Slopes are a major factor related to slip and fall accidents which can result in severe injury. All slopes require extra caution. If you feel uneasy on a slope, do not mow it.

#### DO:

- Mow across the face of slopes: never up and down. Exercise extreme caution when changing direction on slopes.
- Remove obstacles such as rocks, tree limbs, etc.
- Watch for holes, ruts, or bumps. Tall grass can hide obstacles.

#### DO NOT:

- Do not trim near drop-offs, ditches or embankments. The operator could lose footing or balance.
- Do not trim excessively steep slopes.
- Do not mow on wet grass. Reduced footing could cause slipping.

### III. CHILDREN

Tragic accidents can occur if the operator is not alert to the presence of children. Children are often attracted to the machine and the mowing activity. *Never* assume that children will remain where you last saw them.

- Keep children out of the trimming area and under the watchful care of another responsible adult.
- Be alert and turn machine off if children enter the area.
- Before and while walking backwards, look behind and *down* for small children.
- Never allow children to operate the machine.
- Use extra care when approaching blind corners, shrubs, trees, or other objects that may obscure vision.

### IV. SERVICE

- Use extra care in handling gasoline and other fuels. They are flammable and vapors are explosive.
  - Use only an approved container.
  - Never remove gas cap or add fuel with the engine running. Allow engine to cool before refueling. Do not smoke.
  - Never refuel the machine indoors.
  - Never store the machine or fuel container inside where there is an open flame, such as a water heater.
- Never run a machine inside a closed area.
- Never make adjustments or repairs with the engine (motor) running. Disconnect the spark plug wire, and keep the wire away from the plug to prevent accidental starting.
- Keep nuts and bolts, especially blade attachment bolts, tight and keep equipment in good condition.
- Never tamper with safety devices. Check their proper operation regularly.
- Keep machine free of grass, leaves, or other debris build-up. Clean oil or fuel spillage. Allow machine to cool before storing.
- Stop and inspect the equipment if you strike an object. Repair, if necessary, before restarting.
- Never attempt to make wheel height adjustments while the engine (motor) is running.
- Grass catcher components are subject to wear, damage, and deterioration, which could expose moving parts or allow objects to be thrown. Frequently check components and replace with manufacturer's recommended parts, when necessary.
- Mower blades are sharp and can cut. Wrap the blade(s) or wear gloves, and use extra caution when servicing them.
- Do not change the engine governor setting or overspeed the engine.

 Look for this symbol to point out important safety precautions. It means **CAUTION!!! BECOME ALERT!!! YOUR SAFETY IS INVOLVED.**

 **CAUTION:** Always disconnect spark plug wire and place wire where it cannot contact spark plug in order to prevent accidental starting when setting up, transporting, adjusting or making repairs.

 **WARNING:** Engine exhaust, some of its constituents, and certain vehicle components contain or emit chemicals known to the State of California to cause cancer and birth defects or other reproductive harm.

 **WARNING:** Battery posts, terminals and related accessories contain lead and lead compounds, chemicals known to the State of California to cause cancer and birth defects or other reproductive harm. Wash hands after handling.

 **CAUTION:** Muffler and other engine parts become extremely hot during operation and remain hot after engine has stopped. To avoid severe burns on contact, stay away from these areas.



**CONGRATULATIONS** on your purchase of a new lawn mower. It has been designed, engineered and manufactured to give you the best possible dependability and performance. Should you experience any problem you cannot easily remedy, please contact your nearest authorized service center/department. We have competent, well-trained technicians and the proper tools to service or repair this lawn mower.

Please read and retain this manual. The instructions will enable you to assemble and maintain your lawn mower properly. Always observe the "SAFETY RULES".

SERIAL NUMBER: \_\_\_\_\_

DATE OF PURCHASE: \_\_\_\_\_

THE MODEL AND SERIAL NUMBERS WILL BE FOUND ON A DECAL ATTACHED TO THE REAR OF THE LAWN MOWER HOUSING.

YOU SHOULD RECORD BOTH SERIAL NUMBER AND DATE OF PURCHASE AND KEEP IN A SAFE PLACE FOR FUTURE REFERENCE.

**PRODUCT SPECIFICATIONS**

Gasoline Capacity and Type:	1.0 Quarts (Unleaded Regular Only)
Oil Type (API-SF-SJ):	SAE 10W-30
Oil Capacity:	18.5 Ounces
Spark Plug:	NGK BPR6ES (Gap: .030")
Valve Clearance: (± 0.04 mm)	Intake: 0.015 mm Exhaust: 0.020 mm
Blade Bolt Torque:	35-40 ft. lbs.

**CUSTOMER RESPONSIBILITIES**

- Read and observe the safety rules.
- Follow a regular schedule in maintaining, caring for and using your lawn mower.
- Follow the instructions under "Maintenance" and "Storage" sections of this owner's manual.

**TABLE OF CONTENTS**

**SAFETY RULES** ..... 2-3

**PRODUCT SPECIFICATIONS** ..... 3

**CUSTOMER RESPONSIBILITIES** ..... 3

**ASSEMBLY** ..... 4-5

**OPERATION** ..... 6-11

**MAINTENANCE SCHEDULE** ..... 12

**MAINTENANCE** ..... 12-14

**SERVICE AND ADJUSTMENTS** ..... 14-16

**STORAGE** ..... 16-17

**TROUBLESHOOTING** ..... 18

**REPAIR PARTS** ..... 19-23

**WARRANTY** ..... 24

# ASSEMBLY

Read these instructions and this manual in its entirety before you attempt to assemble or operate your new lawn mower.

**IMPORTANT:** THIS LAWN MOWER IS SHIPPED WITHOUT OIL OR GASOLINE IN THE ENGINE.

Your new lawn mower has been assembled at the factory with the exception of those parts left unassembled for shipping purposes. All parts such as nuts, washers, bolts, etc., necessary to complete the assembly have been placed in the parts bag. To ensure safe and proper operation of your lawn mower, all parts and hardware you assemble must be tightened securely. Use the correct tools as necessary to ensure proper tightness.

## TO REMOVE LAWN MOWER FROM CARTON

1. Remove loose parts included with mower.
2. Cut down two end corners of carton and lay end panel down flat.
3. Remove all packing materials except padding between upper and lower handle and padding holding operator presence control bar to upper handle.
4. Roll lawn mower out of carton and check carton thoroughly for additional loose parts.

## HOW TO SET UP YOUR LAWN MOWER TO UNFOLD HANDLE (See Figs. 1 and 2)

**IMPORTANT:** UNFOLD HANDLE CAREFULLY SO AS NOT TO PINCH OR DAMAGE CONTROL CABLES.

1. Raise lower handle to operating position and align hole in handle with one of the height positioning holes in the handle bracket.
2. Insert handle bolt through handle and bracket and secure with knob.
3. Repeat for opposite side of handle.
4. Remove protective padding, raise upper handle section into place on lower handle and tighten both handle knobs.
5. Remove packing material from around control bar.

Your handles may be adjusted for your mowing comfort. Refer to "ADJUST HANDLE" in the Service and Adjustments section of this manual.

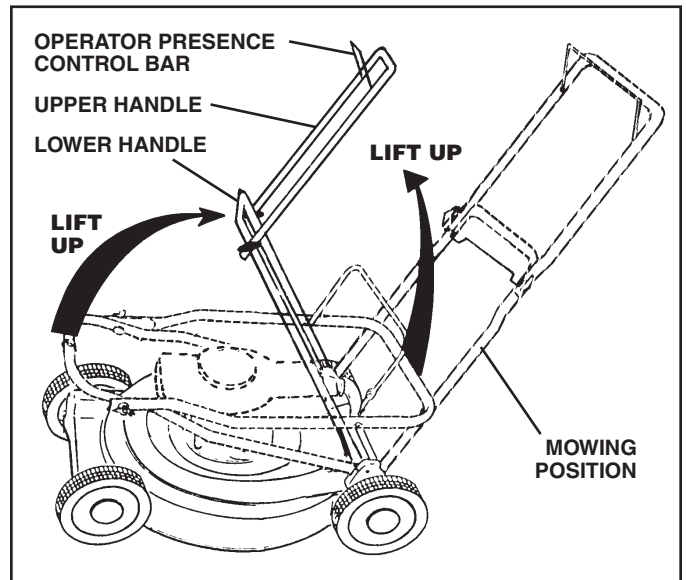

FIG. 1

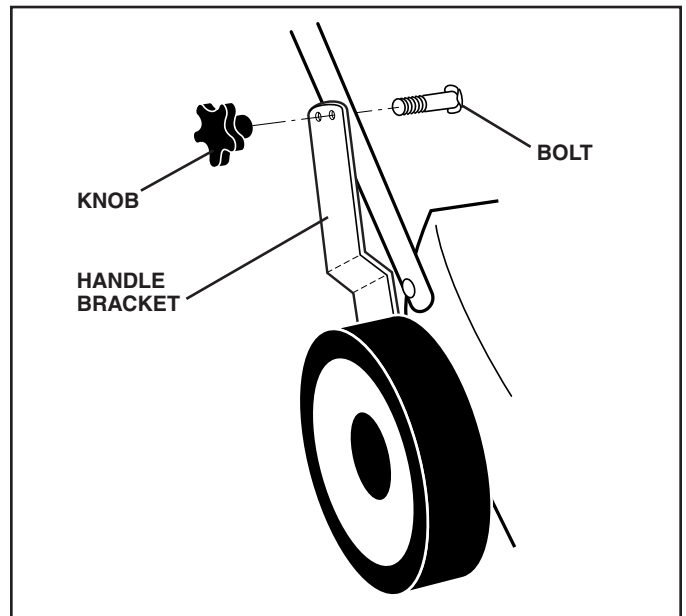

FIG. 2

# ASSEMBLY

## TO ASSEMBLE GRASS CATCHER (See Figs. 3 and 4)

1. Slide grass catcher bag over the frame. Make sure the rear handle is on top (the same side as the front handle) and the strap is on the bottom.
2. Slip vinyl bindings over frame.

**NOTE:** If vinyl bindings are too stiff, hold them in warm water for a few minutes. If bag gets wet, let it dry before using.

3. Close grass catcher door.

**NOTE:** When fully closed, door will “snap” shut over frame and vinyl bindings.

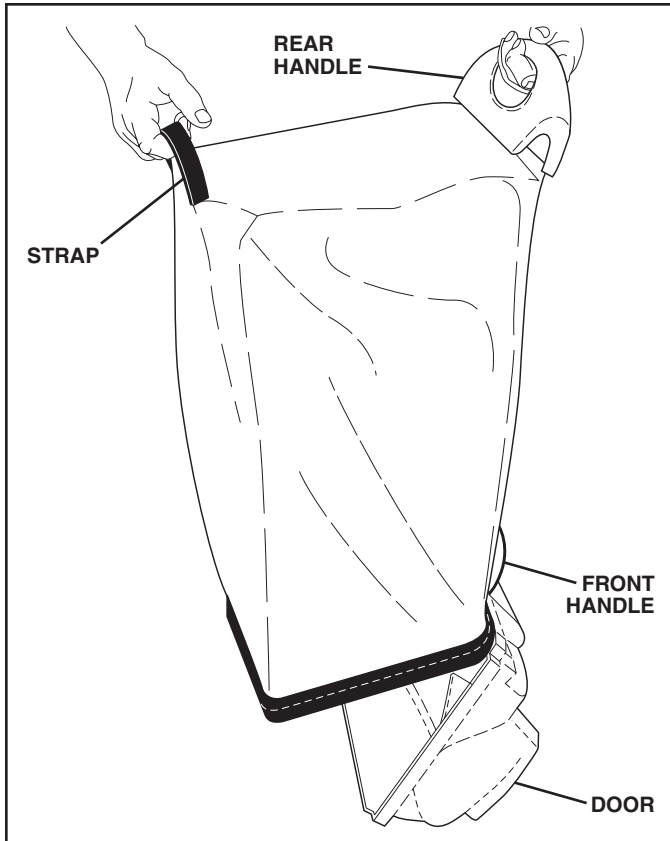

FIG. 3

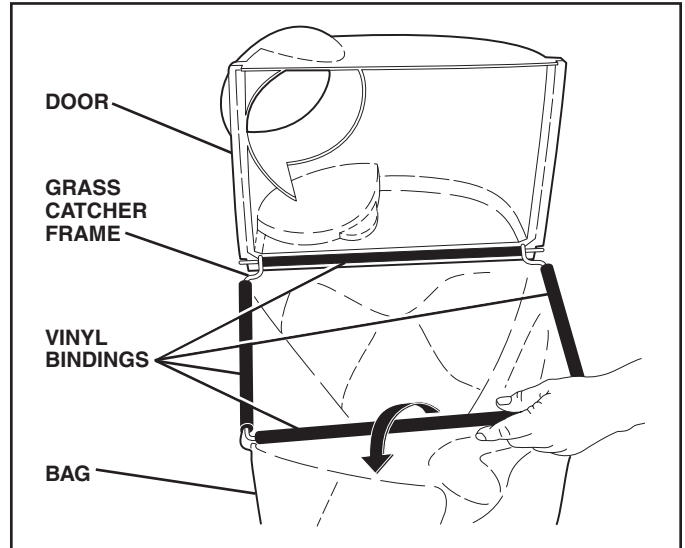

FIG. 4

## TO INSTALL ATTACHMENTS

Your lawn mower was shipped ready to be used as a mulcher. To convert mower to bagging or discharging, see “TO CONVERT MOWER” in the Operation section of this manual.

# OPERATION

## KNOW YOUR LAWN MOWER

READ THIS OWNER'S MANUAL AND SAFETY RULES BEFORE OPERATING YOUR LAWN MOWER.

Compare the illustrations with your lawn mower to familiarize yourself with the location of various controls and adjustments. Save this manual for future reference.

These symbols may appear on your lawn mower or in literature supplied with the product. Learn and understand their meaning.

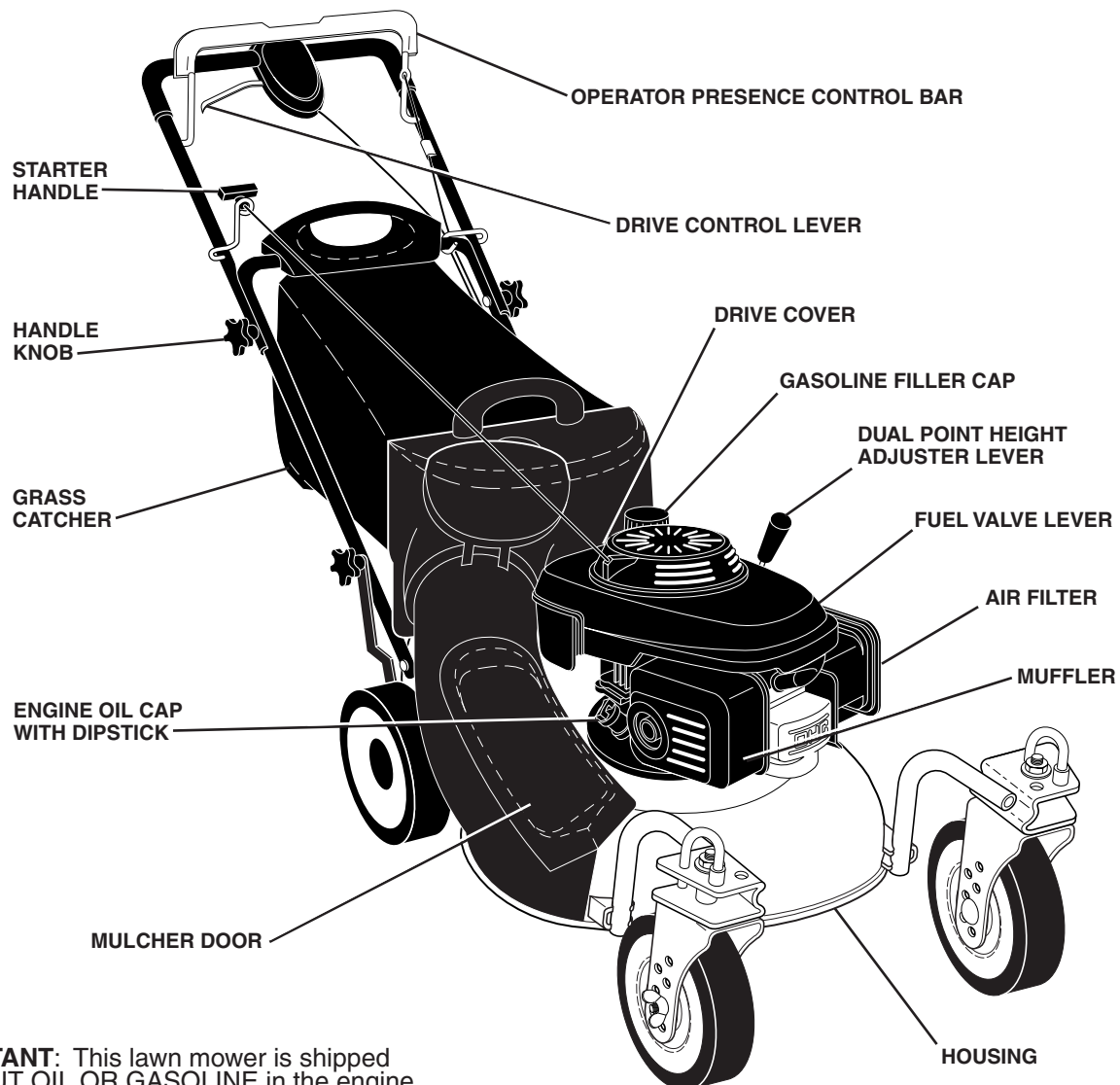
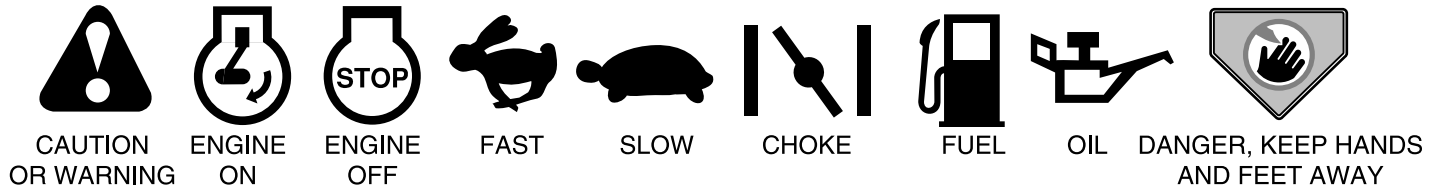

**IMPORTANT:** This lawn mower is shipped WITHOUT OIL OR GASOLINE in the engine.

## MEETS CPSC SAFETY REQUIREMENTS

Our rotary walk-behind power lawn mowers conform to the safety standards of the American National Standards Institute and the U.S. Consumer Product Safety Commission. The blade turns when the engine is running.

**OPERATOR PRESENCE CONTROL BAR** – must be held down to the handle to start engine. Release to stop engine.

**MULCHER DOOR** – allows conversion to discharge or bagging operation.

**STARTER HANDLE** – used for starting the engine.

**DRIVE CONTROL LEVER** – used to engage power-propelled forward motion lawn mower.

**DUAL POINT HEIGHT ADJUSTER** – used to adjust rear cutting height of lawn mower.

# OPERATION



The operation of any lawn mower can result in foreign objects thrown into the eyes, which can result in severe eye damage. Always wear safety glasses or eye shields while operating your lawn mower or performing any adjustments or repairs. We recommend standard safety glasses or a wide vision safety mask over spectacles.

## HOW TO USE YOUR LAWN MOWER

### ENGINE SPEED

The engine speed was set at the factory for optimum performance. Speed is not adjustable.

### ENGINE ZONE CONTROL



**CAUTION:** Federal regulations require an engine control to be installed on this lawn mower in order to minimize the risk of blade contact injury. Do not under any circumstances attempt to defeat the function of the operator control. The blade turns when the engine is running.

- Your lawn mower is equipped with an operator presence control bar which requires the operator to be positioned behind the lawn mower handle to start and operate the lawn mower.

### DRIVE CONTROL (See Fig. 5)

- Self-propelling is controlled by holding the operator presence control bar down to the handle and pulling the drive control lever rearward to the handle. The farther toward the handle the lever is pulled, the faster the unit will travel.
- Forward motion will stop when either the operator presence control bar or drive control lever are released. To stop forward motion without stopping engine, release the drive control lever only. Hold operator presence control bar down against handle to continue mowing without self-propelling.

**NOTE:** If after releasing the drive control the mower will not roll backwards, push the mower forward slightly to disengage drive wheels.

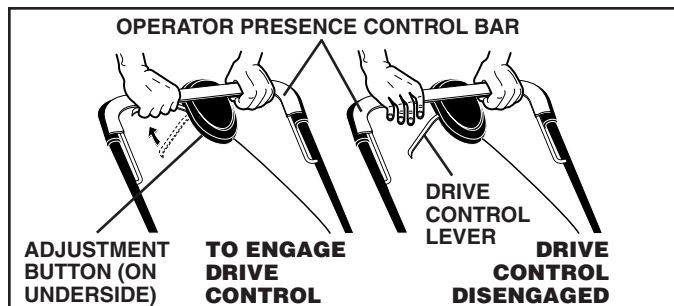

FIG. 5

### DRIVE CONTROL ADJUSTMENT (See Fig. 5)

Over time, the drive control system may become “loose”, resulting in decreased speed. There is a button on the underside of the drive control housing to increase tension on the drive cable. Proceed as follows:

- Turn unit off and disconnect spark plug wire from plug.
- Pull out button on underside of drive control, then push it back in.

- Operate mower to see if drive speed has increased. If there is no increase, the drive belt is worn and needs to be replaced.

### TO ADJUST CUTTING HEIGHT (See Fig. 6)

Both rear wheels are adjusted by a single lever on the left rear wheel.

- Pull adjuster lever toward wheel. To raise mower, move lever forward to desired position. To lower mower, move the lever toward the rear.

**NOTE:** There are seven (7) height adjustment positions for the rear wheels.

Both front wheels are adjusted as follows:

- Remove wheel, bolt, and hardware and reassemble in desired adjustment hole.
- Reinstall wheel components in the same order as they were before removal. Tighten securely.

**NOTE:** There are seven (7) height adjustment holes for the front wheels. Be sure both front wheels are in the same hole.

**IMPORTANT:** BE SURE TO ADJUST BOTH FRONT AND REAR WHEELS TO THE SAME HEIGHT.

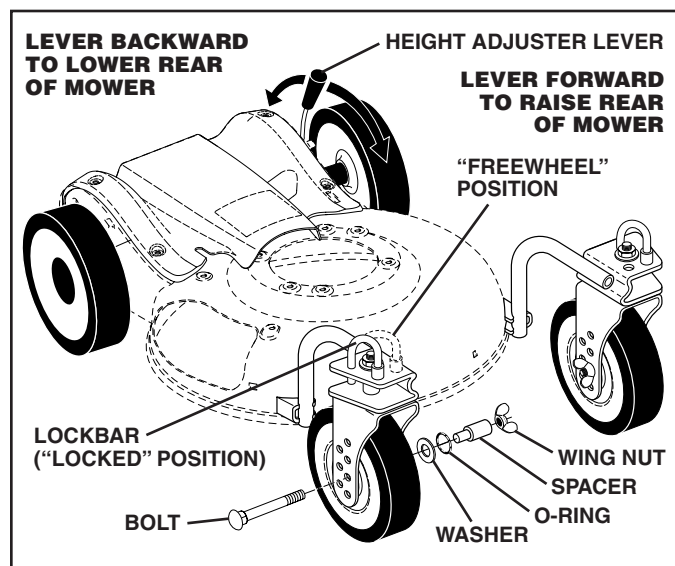

FIG. 6

### CASTER WHEEL OPERATION (See Fig. 6)

The front wheels can be “locked” into position or set to “freewheel” for better maneuverability. Placing the lockbars in the outer holes of the adjustment brackets “locks” the front wheels. Likewise, placing the lockbars in the inner holes of the adjustment brackets allows the front wheels to spin freely (“freewheel”).

- Lift lockbar until the frontmost end clears the adjustment bracket, then pivot lockbar to desired position.

**IMPORTANT:** FRONT WHEELS MUST BE “LOCKED” INTO POSITION WHEN OPERATING ON A SLOPE. MOW ACROSS THE FACE OF SLOPES: NEVER UP AND DOWN.

# OPERATION

## TO CONVERT MOWER (See Figs. 7 thru 9)

Your lawn mower was shipped ready to be used as a mulcher. To convert to rear bagging or side discharging:

### REAR BAGGING

- Remove knob securing mulcher door to mower housing.
- Open mulcher door and insert tabs of discharge chute into hinge bracket opening and position rear of chute over threaded stud.

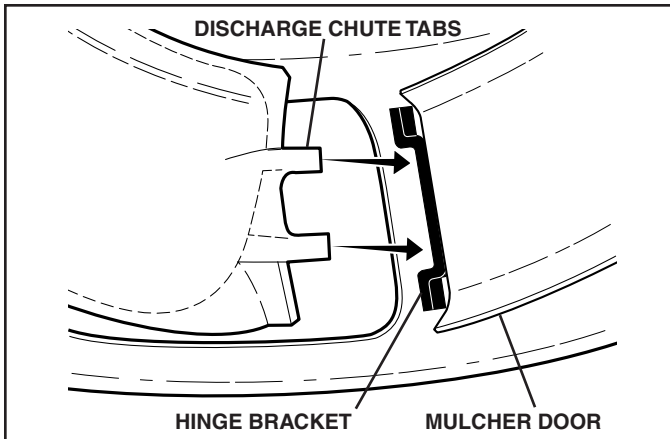

FIG. 7

- Secure rear of discharge chute to lawn mower housing with knob.
- Place rear handle of grass catcher on the crossbar of the lawn mower's lower handle as shown.
- Lift the round door of the discharge chute and place the grass catcher into place on the discharge chute.

**NOTE:** Be sure round door of discharge chute rests on grass catcher as shown.

- Mower is now ready for rear bagging operation.
- To convert to mulching operation, remove grass catcher and discharge chute. Secure mulcher door to mower housing with knob.
- To convert to side discharging operation, remove grass catcher and discharge chute. Install side discharge deflector and secure it to mower housing with knob.

### SIDE DISCHARGING

- Grass catcher and discharge chute must be removed.
- Open mulcher door and install front of side discharge deflector beneath it as shown.
- Secure rear of side discharge deflector to lawn mower housing with knob.
- Mower is now ready for side discharging operation.
- To convert to mulching operation, side discharge deflector must be removed and mulcher door secured to mower housing with knob.
- To convert to rear bagging operation, side discharge deflector must be removed; discharge chute and grass catcher installed and discharge chute secured to mower housing with knob.

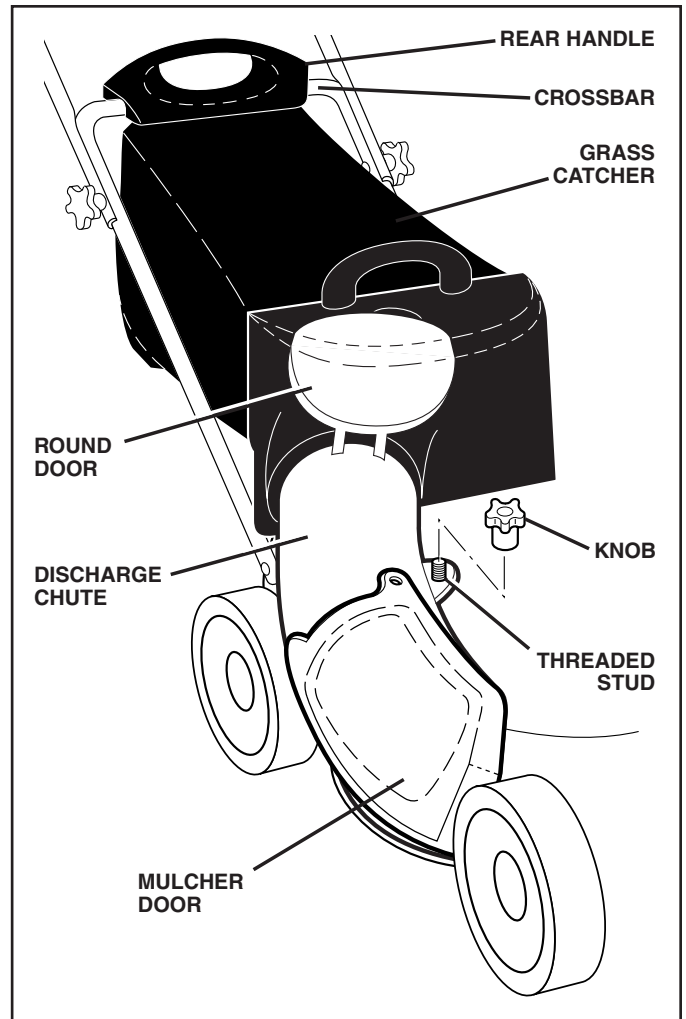

FIG. 8

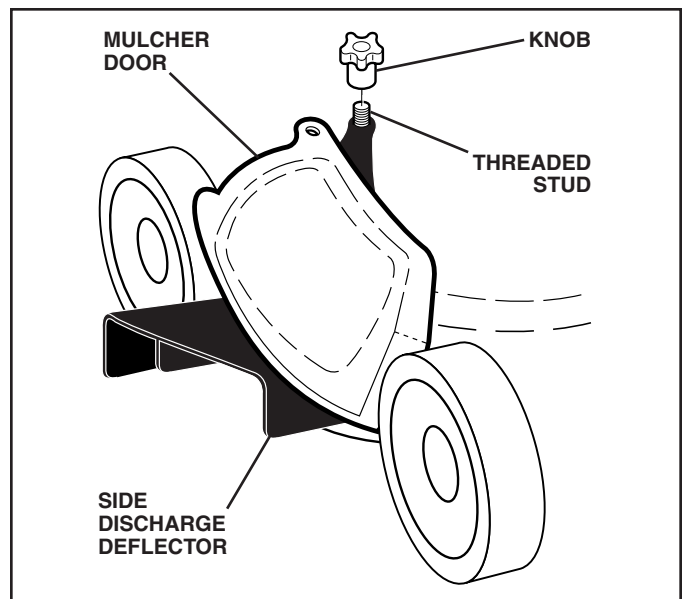

FIG. 9



# OPERATION

## SIMPLE STEPS TO REMEMBER WHEN CONVERTING YOUR LAWN MOWER

### FOR MULCHING -

1. Grass catcher, discharge chute and side discharge deflector removed.
2. Mulcher door secured to mower housing with knob.

### FOR REAR BAGGING -

1. Side discharge deflector removed.
2. Grass catcher and discharge chute installed with discharge chute secured to lawn mower housing with knob.
3. Round door of discharge chute resting on top of grass catcher.

### FOR SIDE DISCHARGING -

1. Grass catcher and discharge chute removed.
2. Side discharge deflector installed and secured to mower housing with knob.



**CAUTION:** Do not run your lawn mower without mulcher door closed; side discharge deflector installed, or discharge chute and approved grass catcher in place. Never attempt to operate the lawn mower with mulcher door or round door removed or propped open.

## TO EMPTY GRASS CATCHER (See Figs. 10 and 11)

1. Open round door of discharge chute to move starter rope out and away from grass catcher.

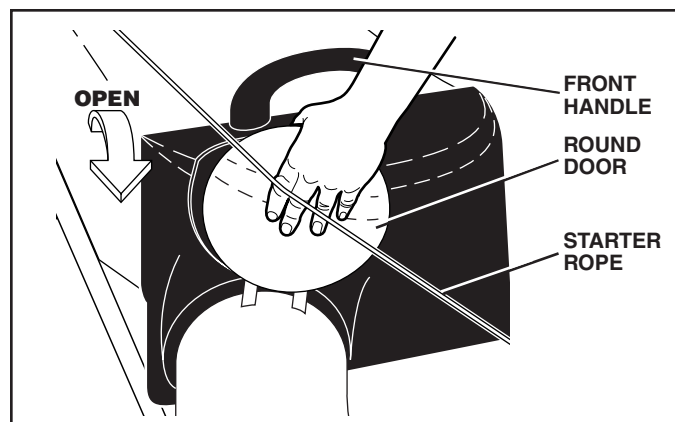

FIG. 10

2. Remove grass catcher with clippings from lawn mower using both front and rear handles.
3. Empty clippings from bag using rear handle and strap. The weight of the grass will open the door.
4. Snap door shut over frame before installing grass catcher on mower.

**NOTE:** Do not drag the bag when emptying; it will cause unnecessary wear.

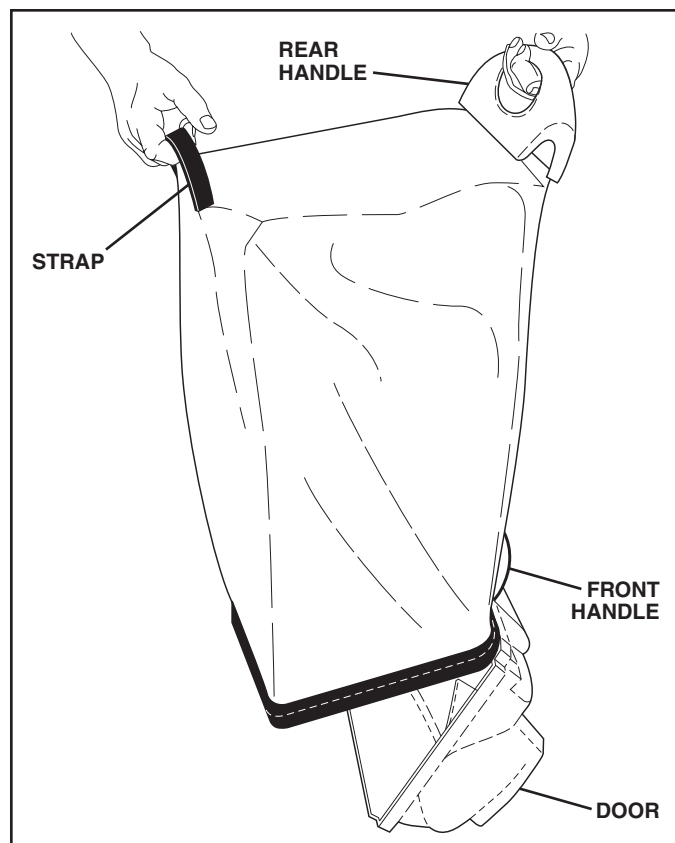

FIG. 11

# OPERATION

## BEFORE STARTING ENGINE

### ADD OIL (See Figs. 12 and 13)

Your lawnmower is shipped without oil in the engine. For type and grade of oil to use, see "ENGINE" in the Maintenance section of this manual.



**CAUTION: DO NOT overfill engine with oil, or it will smoke on startup.**

1. Be sure lawnmower is level and area around oil fill is clean.
2. Remove oil dipstick from oil fill spout. Make sure that rim of spout is clean.
3. Engine holds 18.5 ounces of oil. For type and grade of oil to use, see "ENGINE" in the Maintenance section of this manual.
4. Pour oil slowly. Do not overfill. Wait one minute to allow oil to settle. Use gauge on oil fill cap/dipstick for checking level. Insert dipstick into the tube and rest the oil fill cap on the tube. **DO NOT** thread the cap into the tube when taking reading.
5. Always be sure to tighten dipstick before starting engine.

#### IMPORTANT:

- Check oil level before each use. Add oil if needed. Fill to full line on dipstick.
- Change the oil after every 25 hours of operation or each season. You may need to change the oil more often under dusty, dirty conditions. See "TO CHANGE ENGINE OIL" in the Maintenance section of this manual.

### ADD GASOLINE (See Fig. 13)

- Fill fuel tank to bottom of tank filler neck. Do not overfill. Use fresh, clean, regular unleaded gasoline with a minimum of 87 octane. Do not mix oil with gasoline. Purchase fuel in quantities that can be used within 30 days to assure fuel freshness.

**CAUTION: Wipe off any spilled oil or fuel. Do not store, spill or use gasoline near an open flame.**

Alcohol blended fuels (called gasohol or using ethanol or methanol) can attract moisture which leads to separation and formation of acids during storage. Acidic gas can damage the fuel system of an engine while in storage. To avoid engine problems, the fuel system should be emptied before storage of 30 days or longer. Empty the gas tank, start the engine and let it run until the fuel lines and carburetor are empty. Use fresh fuel next season. See Storage Instructions for additional information. Never use engine or carburetor cleaner products in the fuel tank or permanent damage may occur.

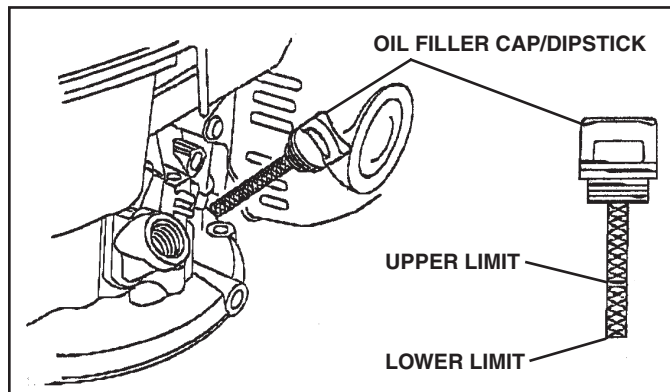

FIG. 12

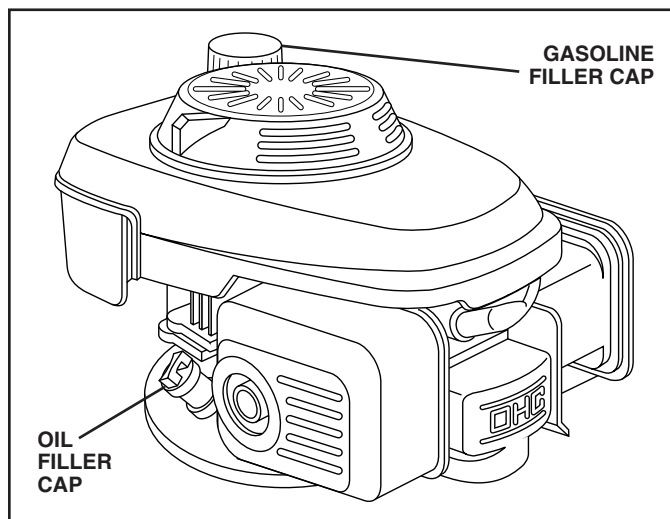

FIG. 13

### TO STOP ENGINE

- To stop engine, release operator presence control bar. Wait until blade and all moving parts have stopped and turn fuel valve to OFF position if you do not intend to restart the engine soon.

### TO START ENGINE (See Fig. 14)

**NOTE:** Due to protective coatings on the engine, a small amount of smoke may be present during the initial use of the product and should be considered normal.

1. Be sure fuel valve is in the ON position.
2. Move choke lever to ON (| \ |) position.
3. Hold operator presence control bar down to the handle and pull starter handle quickly. Do not allow starter rope to snap back.

**NOTE:** The choke lever automatically begins moving to the OFF position when operator presence control bar is held down to handle.

# OPERATION

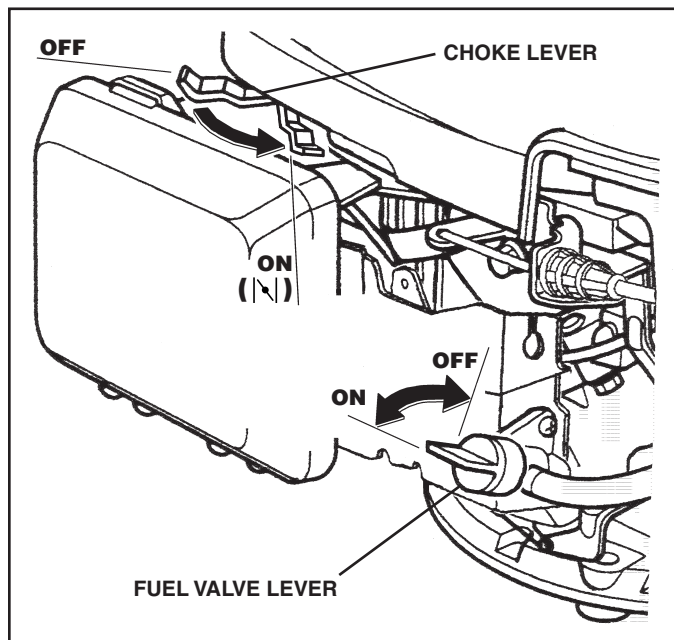

FIG. 14

## MOWING TIPS

- Under certain conditions, such as very tall grass, it may be necessary to raise the height of cut to reduce pushing effort and to keep from overloading the engine and leaving clumps of grass clippings. It may also be necessary to reduce ground speed and/or run the lawn mower over the area a second time.
- For extremely heavy cutting, reduce the width of cut by overlapping previously cut path and mow slowly.
- For better grass bagging and most cutting conditions, the engine speed should be set in the fast position.
- Pores in cloth grass catchers can become filled with dirt and dust with use and catchers will collect less grass. To prevent this, regularly hose catcher off with water and let dry before using.
- Keep top of engine around starter clear and clean of grass clippings and chaff. This will help engine air flow and extend engine life.

## MULCHING MOWING TIPS

**IMPORTANT:** FOR BEST PERFORMANCE, KEEP MOWER HOUSING FREE OF BUILT-UP GRASS AND TRASH. SEE "CLEANING" IN THE MAINTENANCE SECTION OF THIS MANUAL.

- The special mulching blade will recut the grass clippings many times and reduce them in size so that as they fall onto the lawn they will disperse into the grass and not be noticed. Also, the mulched grass will biodegrade quickly to provide nutrients for the lawn. Always mulch with your highest engine (blade) speed as this will provide the best recutting action of the blades.
- Avoid cutting your lawn when it is wet. Wet grass tends to form clumps and interferes with the mulching action. The best time to mow your lawn is the early afternoon. At this time the grass has dried, yet the newly cut area will not be exposed to direct sunlight.
- For best results, adjust the lawn mower cutting height so that the lawn mower cuts off only the top one-third of the grass blades (See Fig. 15). If the lawn is overgrown it will be necessary to raise the height of cut to reduce pushing effort and to keep from overloading the engine and leaving clumps of mulched grass. For extremely heavy mulching, reduce your width of cut by overlapping previously cut path and mow slowly.

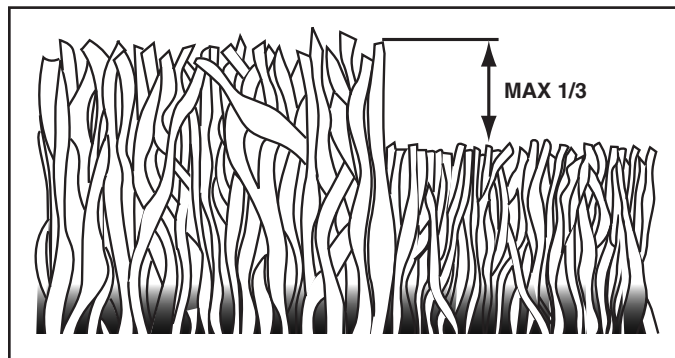

FIG. 15

- Certain types of grass and grass conditions may require that an area be mulched a second time to completely hide the clippings. When doing a second cut, mow across (perpendicular) to the first cut path.
- Change your cutting pattern from week to week. Mow north to south one week then change to east to west the next week. This will help prevent matting and graining of the lawn.

# MAINTENANCE

MAINTENANCE SCHEDULE		BEFORE EACH USE	AFTER EACH USE	EVERY 10 HOURS	EVERY 25 HOURS OR SEASON	EVERY 100 HOURS	BEFORE STORAGE
LAWN MOWER	Check for Loose Fasteners	✓					✓
	Clean / Inspect Grass Catcher *	✓	✓				✓
	Check Tires	✓					
	Check Drive Wheels ***	✓					
	Clean Lawn Mower ****		✓				✓
	Clean under Drive Cover ***			✓			
	Check Drive Belt / Pulleys ***				✓		
	Check / Sharpen / Replace Blade				✓ <sub>3</sub>		
	Lubrication				✓		
	Clean and Recharge Battery **				✓		✓ <sub>4</sub>
ENGINE	Check Engine Oil level	✓ <sub>5</sub>					
	Change Engine Oil				✓ <sub>1,2</sub>		
	Clean Air Filter				✓ <sub>2</sub>		
	Inspect Muffler				✓		
	Replace Spark Plug					✓	
	Replace Air Filter Paper Cartridge					✓ <sub>2</sub>	
	Empty fuel system or add Stabilizer						✓

\* (if so equipped)

\*\* Electric-Start mowers

\*\*\* Power-Propelled mowers

\*\*\*\* Use a scraper to clean under deck

1 - Change more often if operating under a heavy load or in high outdoor temperatures.

2 - Service more often if operating in dirty or dusty conditions.

3 - Replace blades more often when mowing in sandy soil.

4 - Charge 48 hours at end of season.

5 - And after each 5 hours of use.

## GENERAL RECOMMENDATIONS

The warranty on this lawn mower does not cover items that have been subjected to operator abuse or negligence. To receive full value from the warranty, operator must maintain mower as instructed in this manual. Some adjustments will need to be made periodically to properly maintain your unit. At least once a season, check to see if you should make any of the adjustments described in the Service and Adjustments section of this manual.

- At least once a year, replace the spark plug, clean or replace air filter element and check blade for wear. A new spark plug and clean/new air filter element assure proper air-fuel mixture and help your engine run better and last longer.
- Follow the maintenance schedule in this manual.

## BEFORE EACH USE

- Check engine oil level.
- Check for loose fasteners.

## LUBRICATION

Keep unit well lubricated (See "LUBRICATION CHART").

**IMPORTANT:** DO NOT OIL OR GREASE PLASTIC WHEEL BEARINGS. VISCOUS LUBRICANTS WILL ATTRACT DUST AND DIRT THAT WILL SHORTEN THE LIFE OF THE SELF-LUBRICATING BEARINGS. IF YOU FEEL THEY MUST BE LUBRICATED, USE ONLY A DRY, POWDERED GRAPHITE TYPE LUBRICANT SPARINGLY.

## LUBRICATION CHART

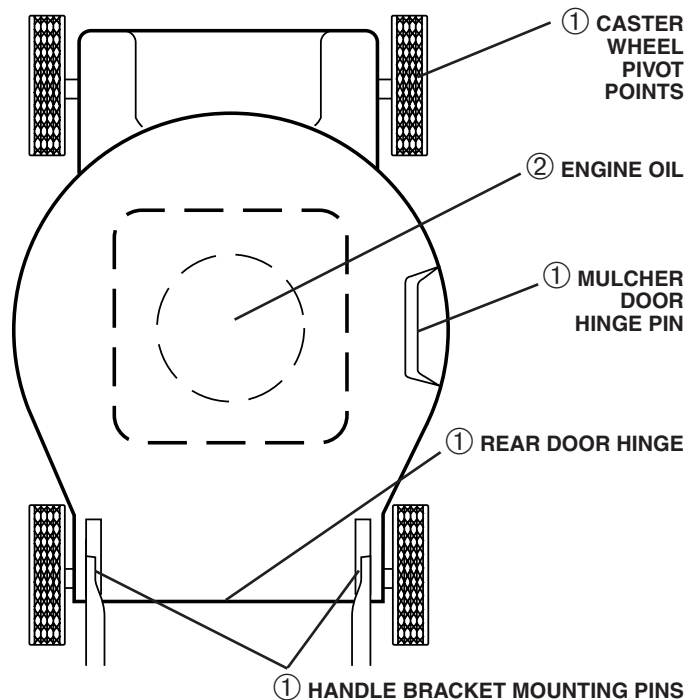

① SPRAY LUBRICANT

② SEE "ENGINE" IN MAINTENANCE SECTION

# MAINTENANCE

## LAWN MOWER

Always observe safety rules when performing any maintenance.

## TIRES

- Keep tires free of gasoline, oil, or insect control chemicals which can harm rubber.
- Avoid stumps, stones, deep ruts, sharp objects and other hazards that may cause tire damage.

## DRIVE WHEELS

Check rear drive wheels each time before you mow to be sure they move freely.

The wheels not turning freely means trash, grass cuttings, etc. are in the drive wheel area and must be cleaned to free drive wheels.

If necessary to clean the drive wheels, be sure to clean both rear wheels.

## BLADE CARE

For best results, mower blade must be kept sharp. Replace bent or damaged blades.

TO REMOVE BLADE (See Fig. 16)

1. Disconnect spark plug wire from spark plug and place wire where it cannot come in contact with spark plug.
2. Turn lawn mower on its side. Make sure air filter and carburetor are up.
3. Use a wood block between blade and mower housing to prevent blade from turning when removing blade bolt.

**NOTE:** Protect your hands with gloves and/or wrap blade with heavy cloth.

4. Remove blade bolt by turning counter-clockwise.
5. Remove blade and attaching hardware (bolt, lock washer and hardened washer).

TO REPLACE BLADE (See Fig. 16)

1. Position blade on the blade adapter aligning the two (2) holes in the blade with the raised lugs on the adapter.
  2. Be sure the trailing edge of blade (opposite sharp edge) is up toward the engine.
  3. Install the blade bolt with the lock washer and hardened washer into blade adapter and crankshaft.
  4. Use block of wood between blade and lawn mower housing and tighten the blade bolt, turning clockwise.
- The recommended tightening torque is 35-40 ft. lbs.

**IMPORTANT:** BLADE BOLT IS HEAT TREATED. IF BOLT NEEDS REPLACING, REPLACE ONLY WITH APPROVED BOLT SHOWN IN THE REPAIR PARTS SECTION OF THIS MANUAL.

TO SHARPEN BLADE

**NOTE:** We do not recommend sharpening blade - but if you do, be sure the blade is balanced.

Care should be taken to keep the blade balanced. An unbalanced blade will cause eventual damage to lawn mower or engine.

- The blade can be sharpened with a file or on a grinding wheel. Do not attempt to sharpen while on the mower.

- To check blade balance, drive a nail into a beam or wall. Leave about one inch of the straight nail exposed. Place center hole of blade over the head of the nail. If blade is balanced, it should remain in a horizontal position. If either end of the blade moves downward, sharpen the heavy end until the blade is balanced.

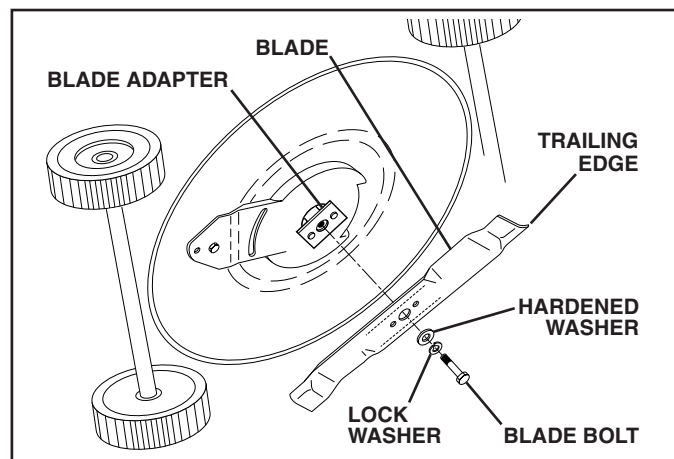

FIG. 16

## GRASS CATCHER

- The grass catcher may be hosed with water, but must be dry when used.
- Check your grass catcher often for damage or deterioration. Through normal use it will wear. If catcher needs replacing, replace only with approved replacement catcher shown in the Repair Parts section of this manual. Give the lawn mower model number when ordering.

## ENGINE

### LUBRICATION

Use only high quality detergent oil rated with API service classification SF-SJ. Select the oil's SAE viscosity grade according to your expected operating temperature.

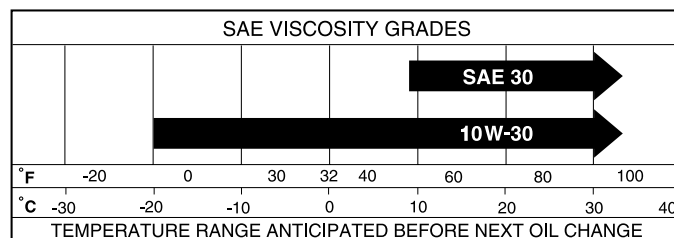

**NOTE:** Multi-viscosity oils (5W30, 10W30 etc.) improve starting in cold weather, and you should check your engine oil level frequently to avoid possible engine damage from running low on oil.

Change the oil after every 25 hours of operation or at least once a year if the lawn mower is not used for 25 hours in one year.

Check the crankcase oil level before starting the engine and after each five (5) hours of continuous use. Tighten oil plug securely each time you check the oil level.

# MAINTENANCE

## TO CHANGE ENGINE OIL (See Fig. 17)

**NOTE:** Before tipping lawn mower to drain oil, empty fuel tank by running engine until fuel tank is empty.

1. Disconnect spark plug wire from spark plug and place wire where it cannot come in contact with spark plug.
2. Remove engine oil cap; lay aside on a clean surface.
3. Tip lawn mower on its side as shown and drain oil into a suitable container. Rock lawn mower back and forth to remove any oil trapped inside of engine.

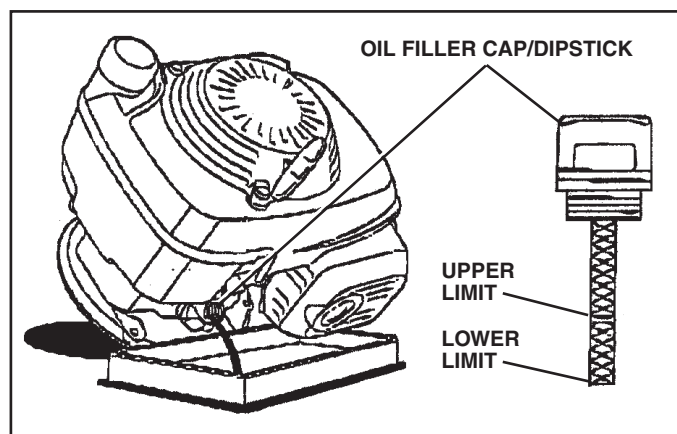

FIG. 17

4. Wipe off any spilled oil from lawn mower or side of engine.
5. Slowly pour oil down the oil fill spout, stopping every few ounces to check the oil level with the dipstick.
6. Stop adding oil when you reach the FULL mark on the dipstick. Wait a minute to allow oil to settle.
7. Continue adding small amounts of oil, rechecking the dipstick until oil level settles at FULL. DO NOT overfill, or engine will smoke heavily from the muffler on startup.
8. Always be sure to retighten oil dipstick before starting engine.
9. Reconnect spark plug wire to spark plug.

## AIR FILTER

Your engine will not run properly and may be damaged by using a dirty air filter. Replace the air filter every 100 hours of operation or every season, whichever occurs first. Service air cleaner more often under dusty conditions. See the maintenance section of your engine manual.

## MUFFLER

Inspect and replace corroded muffler as it could create a fire hazard and/or damage.

## SPARK PLUG

Replace spark plug at the beginning of each mowing season or after every 100 hours of operation, whichever occurs first. Spark plug type and gap setting are shown in the "PRODUCT SPECIFICATIONS" section of this manual.

## CLEANING

**IMPORTANT:** FOR BEST PERFORMANCE, KEEP MOWER HOUSING FREE OF BUILT-UP GRASS AND TRASH. CLEAN THE UNDERSIDE OF YOUR MOWER AFTER EACH USE.



**CAUTION: Disconnect spark plug wire from spark plug and place wire where it cannot come in contact with spark plug.**

- Clean the underside of your lawn mower by scraping to remove build-up of grass and trash.
- Clean engine often to keep trash from accumulating. A clogged engine runs hotter and shortens engine life.
- Keep finished surfaces and wheels free of all gasoline, oil, etc.
- We do not recommend using a garden hose to clean lawn mower unless the electrical system, muffler, air filter and carburetor are covered to keep water out. Water in engine can result in shortened engine life.

## CLEAN UNDER DRIVE COVER

Clean under drive cover at least twice a season. Scrape underside of cover with putty knife or similar tool to remove any build-up of trash or grass on underside of drive cover.

# SERVICE AND ADJUSTMENTS



**CAUTION: TO AVOID SERIOUS INJURY, BEFORE PERFORMING ANY SERVICE OR ADJUSTMENTS:**

1. Release control bar and stop engine.
2. Make sure the blade and all moving parts have completely stopped.
3. Disconnect spark plug wire from spark plug and place where it cannot come in contact with plug.

## LAWN MOWER TO ADJUST CUTTING HEIGHT

See "TO ADJUST CUTTING HEIGHT" in the Operation section of this manual.

## REAR DEFLECTOR

The rear deflector, attached between the rear wheels of your mower, is provided to minimize the possibility that objects will be thrown out of the rear of the mower into the operator's mowing position. If the deflector becomes damaged, it should be replaced.

# SERVICE AND ADJUSTMENTS

## TO REMOVE DRIVE BELT (See Figs. 18–20)

1. Disconnect spark plug wire from spark plug and place wire where it cannot come in contact with spark plug.
2. Remove screws retaining drive cover and remove drive cover from lawn mower housing (See Fig. 18).

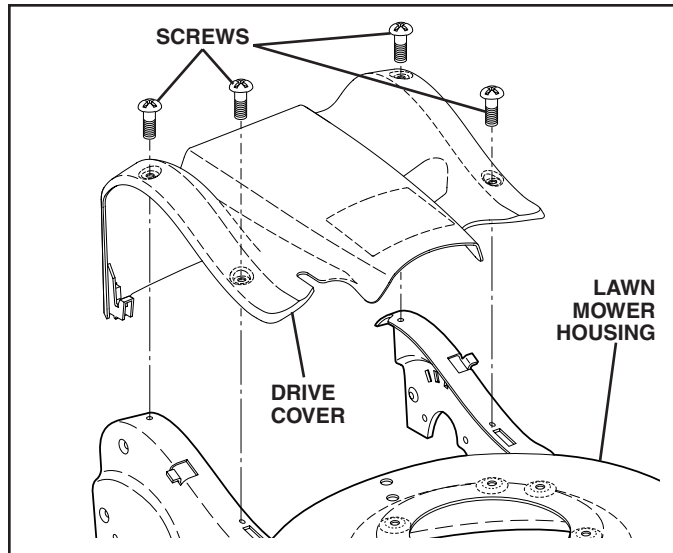

FIG. 18

3. Remove drive cable from anchor, then detach spring from idler arm assembly (See Fig. 19).

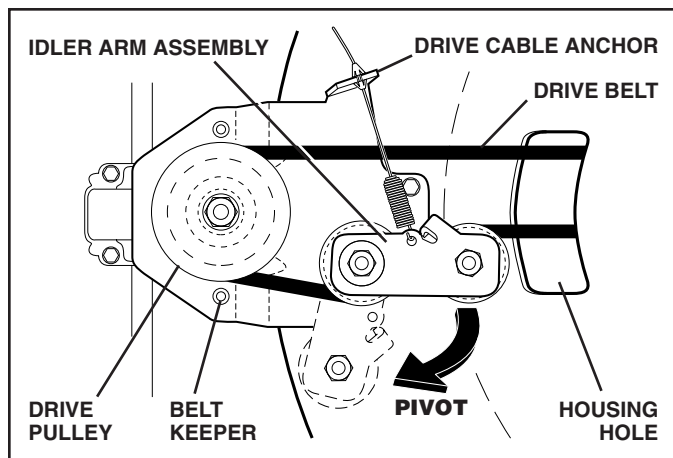

FIG. 19

4. Pivot idler arm assembly to slacken drive belt, then remove drive belt from drive pulley, belt keepers and idler arm.
5. Turn lawn mower on its side. Make sure air filter and carburetor are up.
6. Remove screw securing debris shield. Note that the debris shield has a tab which fits into a gap in the housing (See Fig. 20).

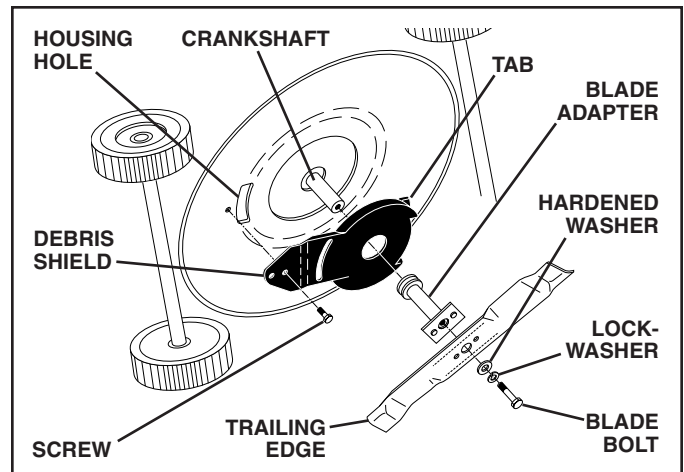

FIG. 20

7. Use a wood block between blade and mower housing to prevent blade from turning when removing blade bolt.

**NOTE:** Protect your hands with gloves and/or wrap blade with heavy cloth.

8. Remove blade bolt.
9. Remove blade, attaching hardware (bolt, lock washer, hardened washer), blade adapter and debris shield as one assembly.
10. Remove drive belt from blade adapter and debris shield; discard old belt.

## TO REPLACE DRIVE BELT (See Fig. 21)

1. Place new drive belt in the belt retainer of the debris shield. Be sure to route belt between belt keepers and through slot as shown (See Fig. 21).

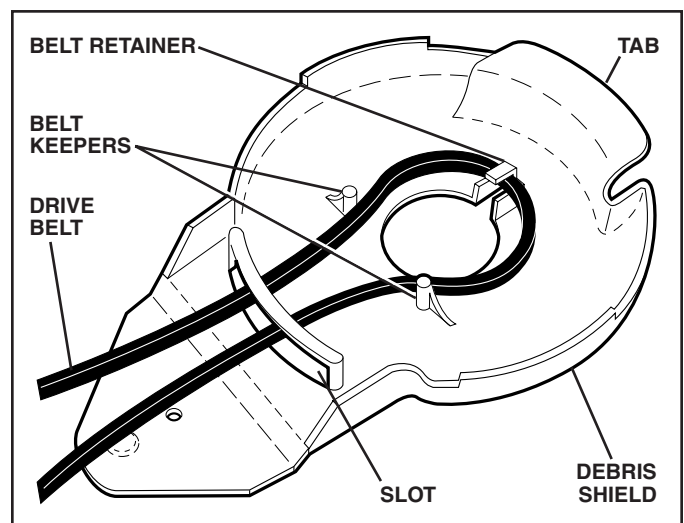

FIG. 21

# SERVICE AND ADJUSTMENTS

2. Route the other end of the new drive belt through hole in housing.
  3. Reattach debris shield to housing with screw previously removed. Be sure tab of debris shield is in gap of housing.
  4. Position blade on the blade adapter aligning the two (2) holes in the blade with the raised lugs on the adapter.
  5. Be sure the trailing edge of blade (opposite sharp edge) is up toward the engine as shown (See Fig. 19).
  6. Install the blade bolt with the lock washer and hardened washer into blade adapter and crankshaft.
  7. Use block of wood between blade and lawn mower housing and tighten the blade bolt, turning clockwise.
- The recommended tightening torque is 35-40 ft. lbs.

**IMPORTANT:** BLADE BOLT IS HEAT TREATED. IF BOLT NEEDS REPLACING, REPLACE ONLY WITH APPROVED BOLT SHOWN IN THE REPAIR PARTS SECTION OF THIS MANUAL.

8. Return mower to upright position.
  9. Install new drive belt into idler arm assembly, then around the drive pulley. Be sure belt is inside of belt keepers (See Fig. 18).
- NOTE:** Pulling on the drive belt (to install it on the drive pulley) will cause the other end of the belt to free itself from the debris shield retainer and come into contact with the pulley end of the blade adapter.
10. Reattach drive cable spring to the idler arm assembly, then reattach drive cable to anchor.
  11. Reattach drive cover with screws previously removed (See Fig. 17).
  12. Connect spark plug wire to spark plug.

## TO ADJUST HANDLE (See Fig. 22)

The handle on your lawn mower has multiple height positions - adjust to height that suits you.

1. Remove knob and carriage bolt on one side of the lower handle.
2. While holding handle assembly, remove knob and carriage bolt from opposite side, align hole in handle with desired hole in handle bracket and reassemble bolt and knob and tighten securely.
3. Align opposite side of handle with same positioning hole and secure with bolt and knob.

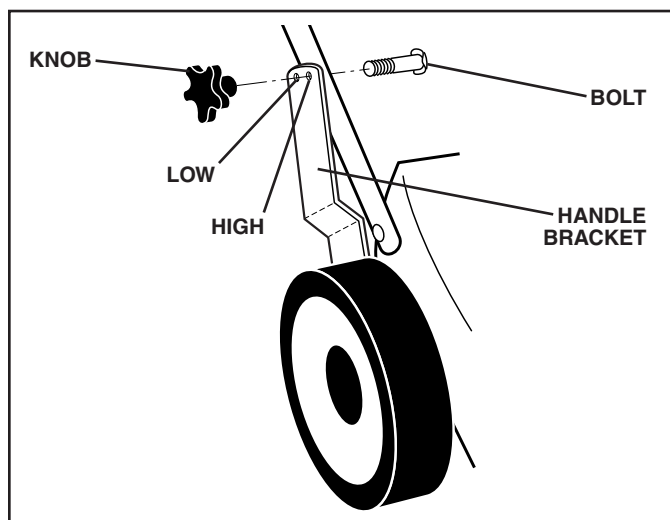

FIG. 22

## ENGINE

Maintenance, repair, or replacement of the emission control devices and systems, which are being done at the customer's expense, may be performed by any non-road engine repair establishment or individual. Warranty repairs must be performed by an authorized engine manufacturer's service outlet.

## ENGINE SPEED

Your engine speed has been factory set. Do not attempt to increase engine speed or it may result in personal injury. If you believe that the engine is running too fast or too slow, take your lawn mower to an authorized service center for repair and adjustment.

## CARBURETOR

Your carburetor is not adjustable. If your engine does not operate properly due to suspected carburetor problems, take your lawn mower to an authorized service center for repair and/or adjustment.

**IMPORTANT:** NEVER TAMPER WITH THE ENGINE GOVERNOR, WHICH IS FACTORY SET FOR PROPER ENGINE SPEED. OVERSPEEDING THE ENGINE ABOVE THE FACTORY HIGH SPEED SETTING CAN BE DANGEROUS. IF YOU THINK THE ENGINE-GOVERNED HIGH SPEED NEEDS ADJUSTING, CONTACT YOUR NEAREST AUTHORIZED SERVICE CENTER, WHICH HAS PROPER EQUIPMENT AND EXPERIENCE TO MAKE ANY NECESSARY ADJUSTMENTS.

# STORAGE

Immediately prepare your lawn mower for storage at the end of the season or if the unit will not be used for 30 days or more.

## LAWN MOWER

When lawn mower is to be stored for a period of time, clean it thoroughly, remove all dirt, grease, leaves, etc. Store in a clean, dry area.

1. Clean entire lawn mower (See "CLEANING" in the Maintenance section of this manual).
2. Lubricate as shown in the Maintenance section of this manual.

3. Be sure that all nuts, bolts, screws, and pins are securely fastened. Inspect moving parts for damage, breakage and wear. Replace if necessary.
4. Touch up all rusted or chipped paint surfaces; sand lightly before painting.



# STORAGE

## HANDLE (See Figs. 23 and 24)

You can fold your lawn mower handle for storage.

1. Loosen the two (2) handle knobs on sides of the upper handle and allow handle to fold down to the rear.
  2. Remove the two (2) handle knobs and carriage bolts on sides of the lower handle and pivot entire handle assembly forward and allow it to rest on mower.
  3. Reinstall knobs and carriage bolts to lower handle or handle brackets for safe keeping.
- When setting up your handle from the storage position, the lower handle will require manually locking into the mowing position.

**IMPORTANT:** WHEN FOLDING THE HANDLE FOR STORAGE OR TRANSPORTATION, BE SURE TO FOLD THE HANDLE AS SHOWN OR YOU MAY DAMAGE THE CONTROL CABLES.

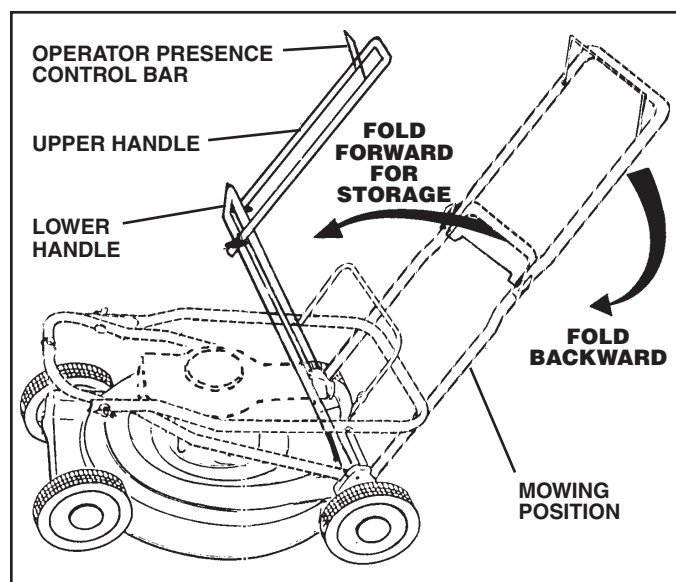

FIG. 23

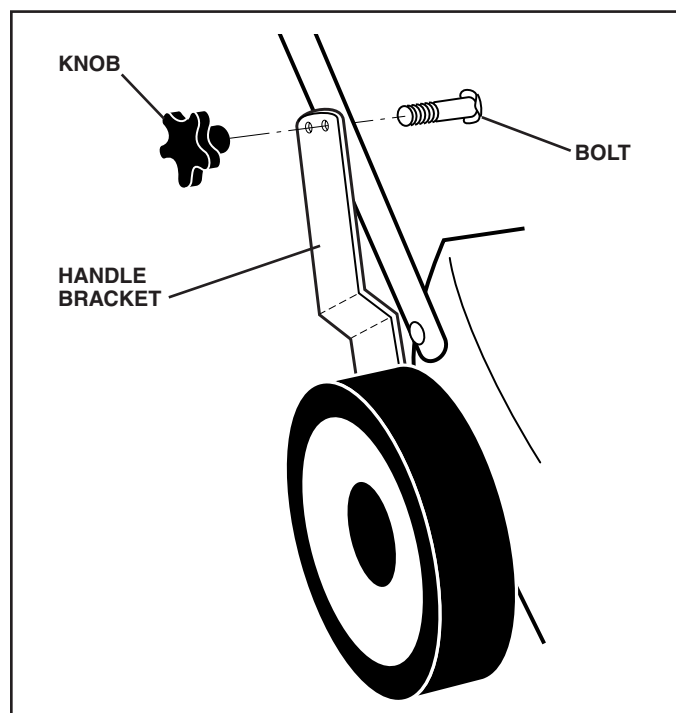

FIG. 24

## ENGINE FUEL SYSTEM

**IMPORTANT:** IT IS IMPORTANT TO PREVENT GUM DEPOSITS FROM FORMING IN ESSENTIAL FUEL SYSTEM PARTS SUCH AS CARBURETOR, FUEL FILTER, FUEL HOSE, OR TANK DURING STORAGE. ALSO, EXPERIENCE INDICATES THAT ALCOHOL BLENDED FUELS (CALLED GASOHOL OR USING ETHANOL OR METHANOL) CAN ATTRACT MOISTURE WHICH LEADS TO SEPARATION AND FORMATION OF ACIDS DURING STORAGE. ACIDIC GAS CAN DAMAGE THE FUEL SYSTEM OF AN ENGINE WHILE IN STORAGE.

- Empty the fuel tank by starting the engine and letting it run until the fuel lines and carburetor are empty.
- Never use engine or carburetor cleaner products in the fuel tank or permanent damage may occur.
- Use fresh fuel next season.

**NOTE:** Fuel stabilizer is an acceptable alternative in minimizing the formation of fuel gum deposits during storage. Add stabilizer to gasoline in fuel tank or storage container. Always follow the mix ratio found on stabilizer container. Run engine at least 10 minutes after adding stabilizer to allow the stabilizer to reach the carburetor. Do not drain the gas tank and carburetor if using fuel stabilizer.

## ENGINE OIL

Drain oil (with engine warm) and replace with clean engine oil. (See "ENGINE" in the Maintenance section of this manual).

## CYLINDER

1. Remove spark plug.
2. Pour one ounce (29 ml) of oil through spark plug hole into cylinder.
3. Pull starter handle slowly a few times to distribute oil.
4. Replace with new spark plug.

## OTHER

- Do not store gasoline from one season to another.
- Replace your gasoline can if your can starts to rust. Rust and/or dirt in your gasoline will cause problems.
- If possible, store your unit indoors and cover it to give protection from dust and dirt.
- Cover your unit with a suitable protective cover that does not retain moisture. Do not use plastic. Plastic cannot breathe which allows condensation to form and will cause your unit to rust.

**IMPORTANT:** NEVER COVER MOWER WHILE ENGINE AND EXHAUST ARE STILL WARM.



**CAUTION:** Never store the lawn mower with gasoline in the tank inside a building where fumes may reach an open flame or spark. Allow the engine to cool before storing in any enclosure.

# TROUBLESHOOTING POINTS

PROBLEM	CAUSE	CORRECTION
<b>Does not start</b>	<ol style="list-style-type: none"> <li>1. Dirty air filter.</li> <li>2. Out of fuel.</li> <li>3. Stale fuel.</li> <li>4. Water in fuel.</li> <li>5. Spark plug wire is disconnected.</li> <li>6. Bad spark plug.</li> <li>7. Loose blade or broken blade adapter.</li> <li>8. Control bar in released position.</li> <li>9. Control bar defective.</li> <li>10. Fuel valve lever (if equipped) in OFF position.</li> <li>11. Weak battery (if equipped).</li> <li>12. Disconnected battery connector (if equipped).</li> </ol>	<ol style="list-style-type: none"> <li>1. Clean/replace air filter.</li> <li>2. Fill fuel tank.</li> <li>3. Empty fuel tank and refill tank with fresh, clean gasoline.</li> <li>4. Empty fuel tank and refill tank with fresh, clean gasoline.</li> <li>5. Connect wire to plug.</li> <li>6. Replace spark plug.</li> <li>7. Tighten blade bolt or replace blade adapter.</li> <li>8. Depress control bar to handle.</li> <li>9. Replace control bar.</li> <li>10. Turn fuel valve lever to the ON position.</li> <li>11. Charge battery.</li> <li>12. Connect battery to engine.</li> </ol>
<b>Loss of power</b>	<ol style="list-style-type: none"> <li>1. Rear of lawn mower housing or cutting blade dragging in heavy grass.</li> <li>2. Cutting too much grass.</li> <li>3. Dirty air filter.</li> <li>4. Buildup of grass, leaves and trash under mower.</li> <li>5. Too much oil in engine.</li> <li>6. Walking speed too fast.</li> </ol>	<ol style="list-style-type: none"> <li>1. Raise cutting height.</li> <li>2. Raise cutting height.</li> <li>3. Clean/replace air filter.</li> <li>4. Clean underside of mower housing.</li> <li>5. Check oil level.</li> <li>6. Cut at slower walking speed.</li> </ol>
<b>Poor cut – uneven</b>	<ol style="list-style-type: none"> <li>1. Worn, bent or loose blade.</li> <li>2. Wheel heights uneven.</li> <li>3. Buildup of grass, leaves and trash under mower.</li> </ol>	<ol style="list-style-type: none"> <li>1. Replace blade. Tighten blade bolt.</li> <li>2. Set all wheels at same height.</li> <li>3. Clean underside of mower housing.</li> </ol>
<b>Excessive vibration</b>	<ol style="list-style-type: none"> <li>1. Worn, bent or loose blade.</li> <li>2. Bent engine crankshaft.</li> </ol>	<ol style="list-style-type: none"> <li>1. Replace blade. Tighten blade bolt.</li> <li>2. Contact a qualified service center.</li> </ol>
<b>Starter rope hard to pull</b>	<ol style="list-style-type: none"> <li>1. Engine flywheel brake is on when control bar is released.</li> <li>2. Bent engine crankshaft.</li> <li>3. Blade adapter broken.</li> <li>4. Blade dragging in grass.</li> </ol>	<ol style="list-style-type: none"> <li>1. Depress control bar to upper handle before pulling starter rope.</li> <li>2. Contact a qualified service center.</li> <li>3. Replace blade adapter.</li> <li>4. Move lawn mower to cut grass or other hard surface before starting.</li> </ol>
<b>Grass catcher not filling (if so equipped)</b>	<ol style="list-style-type: none"> <li>1. Cutting height too low.</li> <li>2. Lift on blade worn off.</li> <li>3. Catcher not venting air.</li> </ol>	<ol style="list-style-type: none"> <li>1. Raise cutting height.</li> <li>2. Replace blade.</li> <li>3. Clean grass catcher.</li> </ol>
<b>Hard to push</b>	<ol style="list-style-type: none"> <li>1. Grass is too high or wheel height is too low.</li> <li>2. Rear of lawn mower housing or cutting blade dragging in heavy grass.</li> <li>3. Grass catcher too full.</li> <li>4. Handle height position not right for you.</li> </ol>	<ol style="list-style-type: none"> <li>1. Raise cutting height.</li> <li>2. Raise rear of lawn mower housing one (1) setting higher.</li> <li>3. Empty grass catcher.</li> <li>4. Adjust handle height to suit.</li> </ol>
<b>Loss of drive (or slowing of drive speed)</b>	<ol style="list-style-type: none"> <li>1. Belt wear.</li> <li>2. Belt off of pulley.</li> <li>3. Drive cable worn or broken.</li> <li>4. “Loose” drive control system.</li> </ol>	<ol style="list-style-type: none"> <li>1. Check/replace drive belt.</li> <li>2. Check/reinstall drive belt.</li> <li>3. Put belt on pulleys / replace belts if broken.</li> <li>4. Adjust drive control.</li> </ol>

**ROTARY LAWN MOWER - - MODEL NUMBER 65RSW21HV (65RSW21HVA)  
GEAR CASE ASSEMBLY - - PART NUMBER 532 18 36-99**

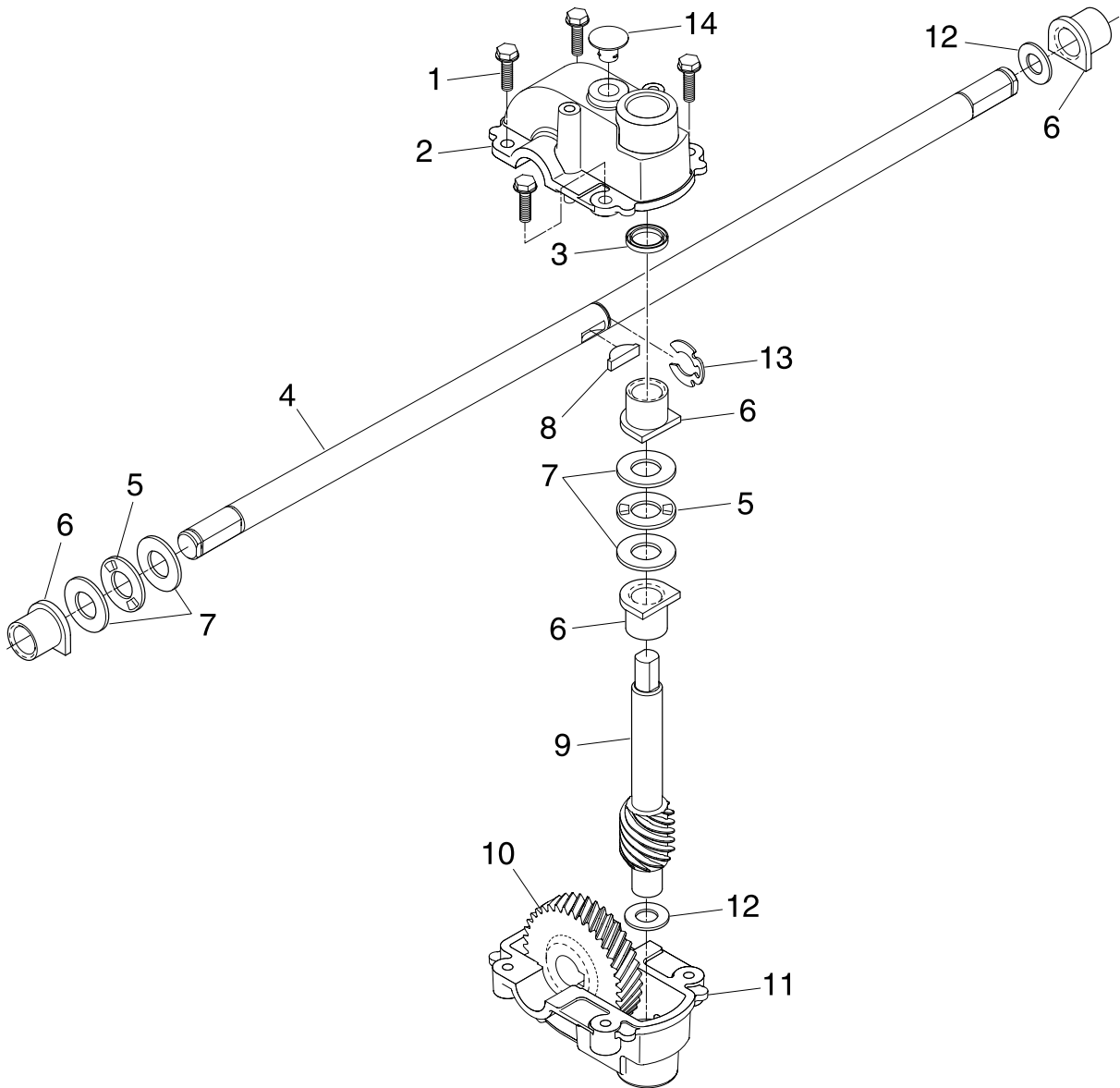

KEY NO.	PART NO.	DESCRIPTION
1	817 54 10-11	Screw, Tapping #10-24 x .668
2	532 16 06-72	Gear Case, Upper
3	532 05 70-72	Seal
4	532 18 39-08	Drive Shaft
5	532 16 08-18	Bearing, Needle, Thrust
6	532 07 78-81	Bearing
7	532 16 08-17	Washer, Thrust
8	532 85 08-48	Key, Hi-pro
9	532 18 41-34	Shaft, Worm
10	532 16 06-79	Gear, Helical
11	532 16 06-73	Gear Case, Lower
12	532 05 70-79	Washer, Hardened
13	812 00 00-39	E-Ring
14	532 08 64-47	Plug
--	532 75 03-69	Grease

**NOTE:** All component dimensions given in U.S. inches.  
1 inch = 25.4 mm

# ROTARY LAWN MOWER - - MODEL NUMBER 65RSW21HV (65RSW21HVA)

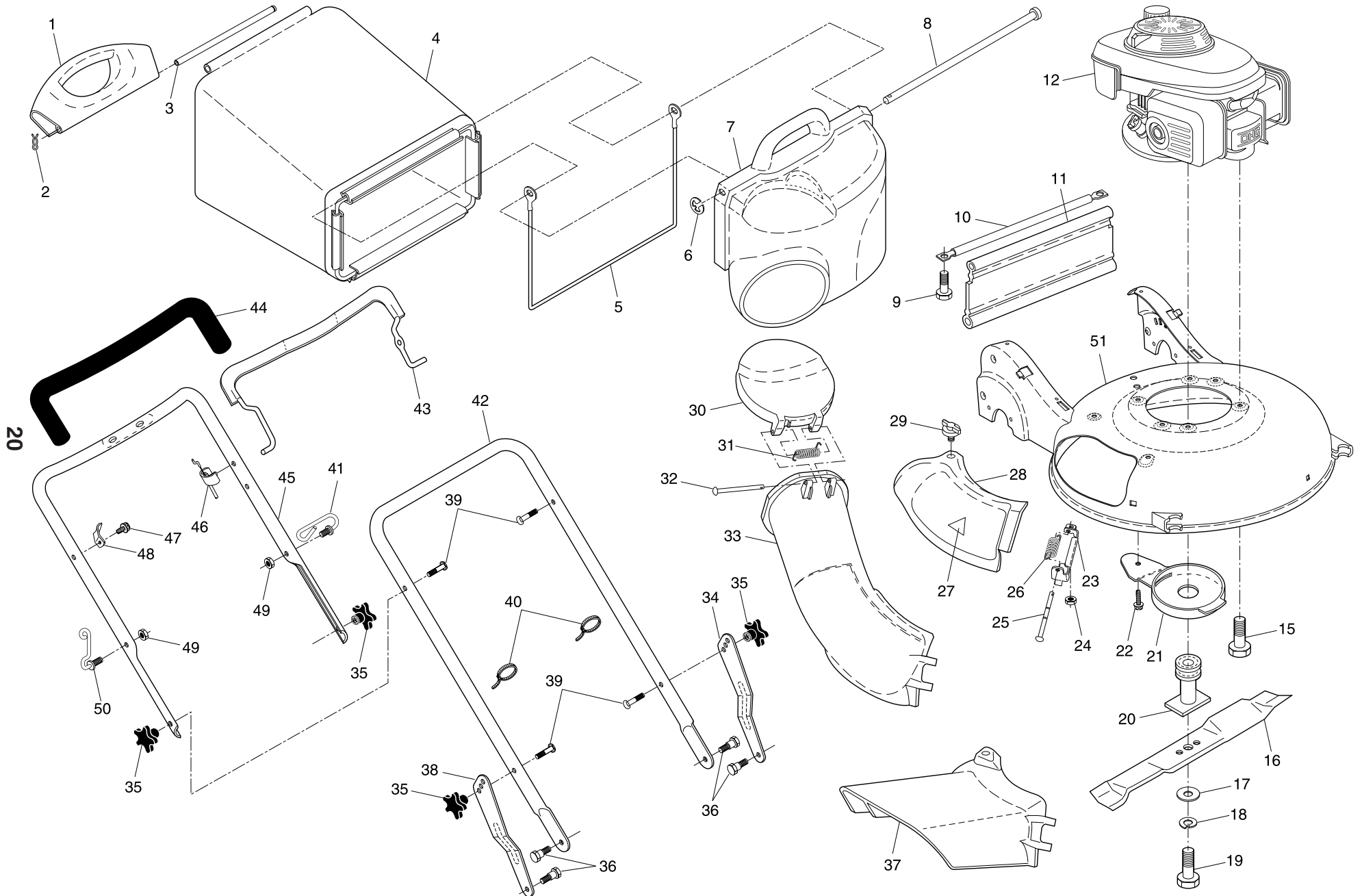

## ROTARY LAWN MOWER - - MODEL NUMBER 65RSW21HV (65RSW21HVA)

KEY NO.	PART NO.	DESCRIPTION	KEY NO.	PART NO.	DESCRIPTION
1	532 18 60-03	Handle, Grassbag, Rear	29	532 18 34-47	Knob
2	532 06 53-22	Hairpin Cotter	30	532 18 60-01	Door, Discharge Chute
3	532 18 34-83	Rod, Rear Handle, Grassbag	31	532 18 34-78	Spring, Door, Discharge Chute
4	532 18 52-28	Grassbag	32	532 18 34-45	Rod, Door, Discharge Chute
5	532 18 34-81	Frame, Grassbag	33	532 18 60-00	Discharge Chute, Plastic
6	812 00 00-14	E-Ring	--	532 18 63-01	Discharge Chute Assembly, Complete (Consists of Key Numbers 30-33)
7	532 18 60-02	Door, Grassbag	34	532 18 74-25	Adjustment Bracket, Lower Handle, LH
8	532 18 34-79	Rod, Pivot	35	532 18 55-88	Knob, Star
--	532 18 63-02	Grassbag Assembly, Complete (Consists of Key Numbers 1-8)	36	532 18 34-65	Bolt, Shoulder
9	817 41 13-18	Screw	37	532 18 59-96	Deflector, Discharge
10	532 18 43-31	Tube, Rear Skirt	38	532 18 74-26	Adjustment Bracket, Lower Handle, RH
11	532 18 34-63	Skirt, Rear	39	532 18 45-68	Bolt, Handle
12	---	Engine, Honda, Model Number GCV190 (Order parts from Engine Manufacturer)	40	532 06 64-26	Wire Tie
15	532 15 04-06	Bolt, Engine Mounting	41	532 18 71-62	Bracket, Anti-Fold
16	532 15 92-67	Blade, 21"	42	532 18 70-96	Handle Assembly, Lower
17	532 85 10-74	Washer, Hardened	43	532 18 62-98	Bail, Control
18	532 85 02-63	Washer, Lock	44	532 18 27-48	Grip, Foam
19	532 18 34-31	Screw, Hex Head, Grade 8	45	532 18 62-96	Handle Assembly, Upper (Includes Foam Grip)
20	532 18 34-28	Adapter, Blade	46	532 18 34-73	Cable, Engine Zone Control
21	532 18 36-90	Debris Shield	47	532 18 45-70	Screw
22	817 60 04-06	Screw, Hex Head, Serrated	48	532 12 52-03	Bracket, Upstop
23	532 18 36-09	Mounting Bracket, Mulcher Door	49	532 18 45-69	Nut, Hex
24	532 75 11-52	Nut, Hex	50	532 18 34-69	Rope Guide
25	532 18 34-45	Rod, Hinge	51	532 18 64-77	Kit, Housing
26	532 18 34-46	Spring, Mulcher Door	--	532 16 23-00	Decal, Warning (not shown)
27	532 10 73-39	Decal, Danger	--	532 18 74-62	Owner's Manual
28	532 18 59-95	Mulcher Door			

**NOTE:** All component dimensions given in U.S. inches.  
1 inch = 25.4 mm

# ROTARY LAWN MOWER - - MODEL NUMBER 65RSW21HV (65RSW21HVA)

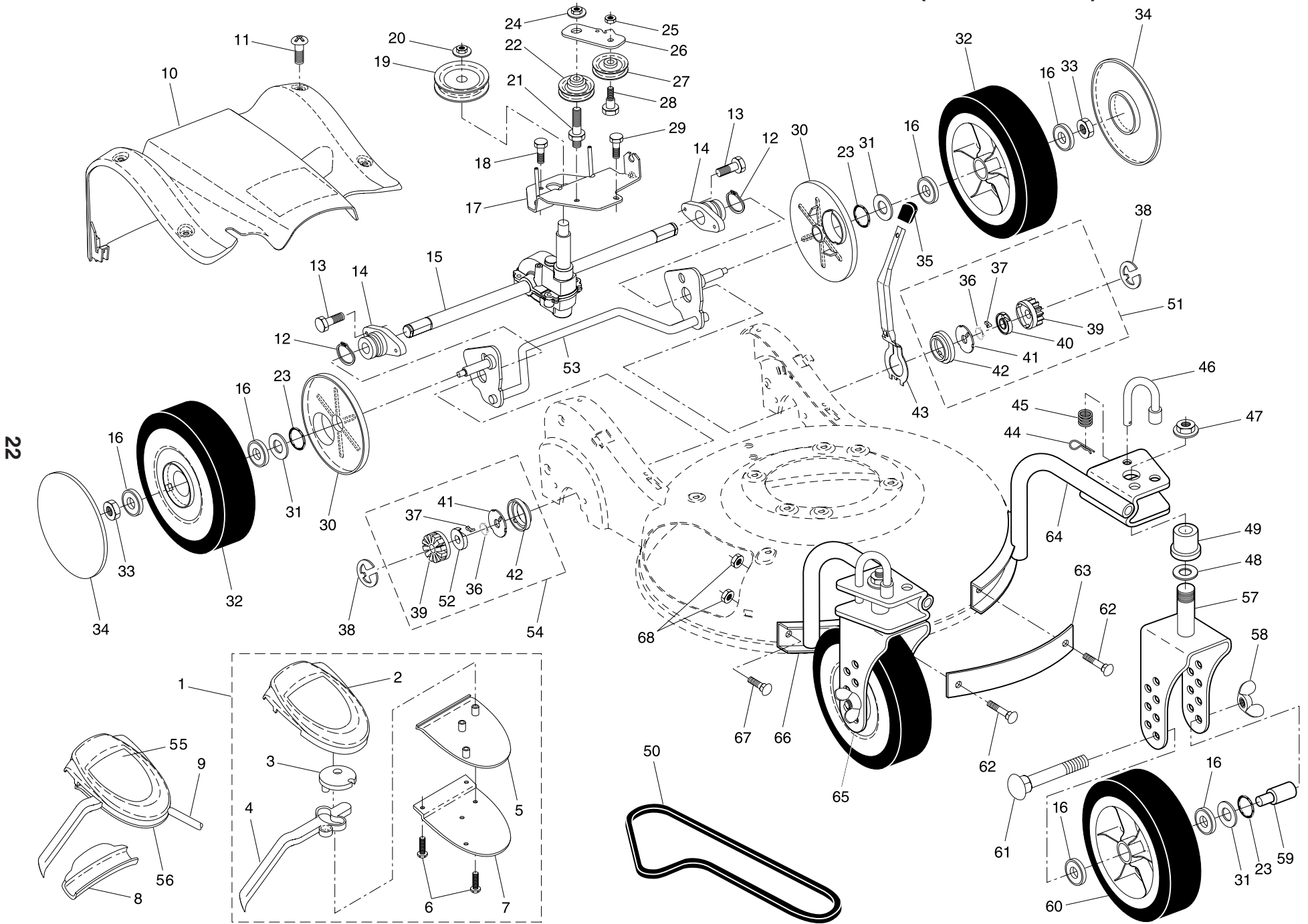

## ROTARY LAWN MOWER - - MODEL NUMBER 65RSW21HV (65RSW21HVA)

KEY NO.	PART NO.	DESCRIPTION	KEY NO.	PART NO.	DESCRIPTION
1	532 18 53-12	Drive Control Assembly, Complete (Consists of Key Numbers 2 through 7)	36	532 18 82-91	Spring, Torsion
2	532 18 82-79	Cover, Drive Control, Top	37	532 17 50-98	Pawl
3	532 18 73-53	Pulley, Drive Control	38	812 00 00-58	E-Ring
4	<b>532 19 02-83</b>	Lever, Drive Control (blue)	39	532 17 51-03	Gear
5	532 18 82-78	Cover, Drive Control, Bottom	40	532 17 51-05	Retainer, Drive, LH
6	532 18 16-98	Screw, Torx Head #8-5/8	41	532 17 51-04	Disc, Drive
7	532 18 70-97	Bracket, Mounting, Drive Control	42	532 18 41-72	Seal, Friction
8	532 18 62-97	Cap, Drive Control, Bottom	43	532 18 76-81	Lever, Selector, Wheel Height, Rear
9	<b>532 18 82-80</b>	Cable, Drive Control	44	532 06 53-32	Clip, Retainer
10	532 18 59-97	Cover Assembly, Drive	45	532 18 50-51	Spring
11	532 18 45-71	Screw	46	532 18 50-54	Rod, Lock
12	812 00 00-12	Ring, Retaining	47	532 18 72-47	Nut, Hex, Flangelock
13	532 18 34-50	Screw	48	819 17 17-13	Washer, Flat 1/2
14	532 18 71-20	Bearing / Axle Support	49	532 18 50-50	Bushing
15	532 18 36-99	Gear Case Assembly (See Breakdown)	50	532 18 36-88	Belt, Drive
16	532 75 10-68	Bearing, Ball (Wheel)	51	532 18 83-31	Pinion Assembly, LH
17	532 18 70-93	Bracket, Gear Case / Drive Pulley	52	532 17 51-02	Retainer, Drive, RH
18	817 54 10-11	Screw	53	532 18 70-91	Rear Axle Assembly
19	532 18 47-49	Pulley, Drive	54	532 18 83-30	Pinion Assembly, RH
20	532 13 20-10	Nut, Hex, Flangelock	55	532 18 73-56	Decal, Drive Control
21	532 18 37-01	Bolt, Idler	56	532 18 59-13	Decal, Drive Control Adjustment (bottom)
22	532 18 45-43	Pulley Assembly, V-Groove	57	532 18 76-82	Bracket, Caster Wheel, LH
23	532 18 81-52	O-Ring	58	532 18 72-48	Wing Nut 5/16-18
24	532 14 52-12	Nut, Hex, Flangelock	59	532 18 51-11	Spacer
25	873 93 05-00	Nut, Hex, Lock	60	532 18 64-40	Wheel Assembly, Front 9 x 2-1/4
26	532 18 70-98	Idler Arm	61	872 27 05-28	Bolt, Carriage 5/16-18 x 3-1/2
27	532 16 60-43	Pulley, Idler	62	532 18 74-74	Bolt, Carriage 5/16-18 x 7/8
28	532 16 08-29	Bolt, Hex Head, Shoulder	63	532 18 74-67	Strap, Front
29	817 06 04-10	Screw 1/4-20 x 1/16	64	532 18 76-83	Support Tube Assembly, LH
30	532 18 34-57	Cover, Dust, Wheel	65	532 18 76-84	Bracket, Caster Wheel, RH
31	532 08 83-48	Washer, Flat 3/8	66	532 18 76-85	Support Tube Assembly, RH
32	532 18 43-68	Wheel Assembly, Rear 9 x 2-1/4	67	532 18 75-55	Bolt, Carriage 5/16-18 x 5/8
33	532 08 39-23	Nut, Hex	68	532 18 72-63	Nut, Hex 5/16
34	532 18 36-95	Hubcap			
35	532 18 59-94	Knob			

**NOTE:** All component dimensions given in U.S. inches.  
1 inch = 25.4 mm



# WARRANTY STATEMENT

## SECTION 1: LIMITED WARRANTY

Husqvarna Forest & Garden Company ("Husqvarna") warrants Husqvarna product to the original purchaser to be free from defects in material and workmanship from the date of purchase for the "Warranty Period" of the product as set forth below:

**Lifetime Warranty:** All tiller lines against breakage, trimmer shafts, ignition coils and modules on hand held product.

**3 Year Warranty:** Spindles (on Zero Turn Riders and Commercial Walk-Behinds)

**2 Year COMMERCIAL-Warranty:** Husqvarna Commercial Turf Equipment—zero turn riders, wide area walks, and ground engaging commercial equipment.

**2 Year NON-COMMERCIAL Warranty:** Automatic Mower, Riding lawn mowers, yard and garden tractors, walk behind mowers, tillers, chain saws, trimmers, brushcutters, clearing saws, snow blowers, handheld blowers, backpack blowers, hedge trimmers, electrical products and power-assist collection systems for noncommercial, nonprofessional, noninstitutional or nonincome producing use, except as herein stated.

Emission control system components necessary to comply with CARB-TIER-II and EPA regulations, except for those components which are part of engine systems manufactured by third party engine manufacturers for which the purchaser has received a separate warranty with product information supplied at time of purchase.

**1 Year Warranty:** Power cutters, stump grinders, pole pruners and pole saws for non-commercial, non-professional, non-institutional or non-income producing use. All trimmers, brushcutters, clearing saws, hovering trimmers, stick edgers, backpack blowers, hand held blowers, hedge trimmers, power-assist collection systems used for commercial, institutional, professional or income-producing purposes or use.

**Batteries** have a one-year prorated limited warranty with 100% replacement during the first 6 months.

**90 Day Warranty:** Automatic Mower, Chain saws, power cutters, stump grinders, pole saws, pole pruners, snow throwers, model series 580 & 600 walk-behind mowers and commercial turf equipment or any Husqvarna product used for commercial, institutional, professional, or income-producing purposes or use except as otherwise provided herein.

**Husqvarna Safety Apparel** carries a 90-day warranty from the date of the customer's original purchase for defects in material and workmanship. Normal wear, tear or abuse is not covered under warranty. Product must be returned to Charlotte with a warranty claim form. All care and maintenance instructions must be followed as stated by the manufacturer on the care label. The fit of the protective apparel/boot is not covered under warranty.

**30 Day Warranty:** Replacement parts, accessories including bars and chains, tools and display items.

## SECTION 2: HUSQVARNA'S OBLIGATIONS UNDER THE WARRANTY

Husqvarna will repair or replace defective components without charge for parts or labor if a component fails because of a defect in material or workmanship during the warranty period.

## SECTION 3: ITEMS NOT COVERED BY THIS WARRANTY

The following items are not covered by this warranty:

- (1) Normal customer maintenance items which become worn through normal regular use, including, but not limited to, belts, blades, blade adapters, bulbs, filters, guide bars, lubricants, rewind springs, saw chain, spark plugs, starter ropes and tines;
- (2) Natural discoloration of material due to ultraviolet light;
- (3) Engine and drive systems not manufactured by Husqvarna; these items are covered by the respective manufacturer's warranty as provided in writing with the product information supplied at the time of purchase; all claims must be sent to the appropriate manufacturer;
- (4) Lawn and garden attachments are covered by a third party which gives a warranty, all claims for warranty should be sent to the manufacturer; and
- (5) Emission Control System components necessary to comply with CARB-TIER-II and EPA regulations which are manufactured by third party engine manufacturer.

## SECTION 4: EXCEPTIONS AND LIMITATIONS

This warranty shall be inapplicable to defects resulting from the following:

- (1) Accident, abuse, misuse, negligence and neglect, including stale fuel, dirt, abrasives, moisture, rust, corrosion, or any adverse reaction due to incorrect storage or use habits;
- (2) Failure to operate or maintain the unit in accordance with the Owner's/Operator's manual or instruction sheet furnished by Husqvarna;
- (3) Alterations or modifications that change the intended use of the product or affects the product's performance, operation, safety, or durability, or causes the product to fail to comply with any applicable laws; or;
- (4) Additional damage to parts or components due to continued use occurring after any of the above.

REPAIR OR REPLACEMENT AS PROVIDED UNDER THIS WARRANTY IS THE EXCLUSIVE REMEDY OF THE PURCHASER. HUSQVARNA SHALL NOT BE LIABLE FOR ANY INCIDENTAL OR CONSEQUENTIAL DAMAGES FOR BREACH OF ANY EXPRESS OR IMPLIED WARRANTY ON THESE PRODUCTS EXCEPT TO THE EXTENT PROHIBITED BY APPLICABLE LAW. ANY IMPLIED WARRANTY OF MERCHANTABILITY OR FITNESS FOR A PARTICULAR PURPOSE ON THESE PRODUCTS IS LIMITED IN DURATION TO THE WARRANTY PERIOD AS DEFINED IN THE LIMITED WARRANTY STATEMENT. HUSQVARNA RESERVES THE RIGHT TO CHANGE OR IMPROVE THE DESIGN OF THE PRODUCT WITHOUT NOTICE, AND DOES NOT ASSUME OBLIGATION TO UPDATE PREVIOUSLY MANUFACTURED PRODUCTS.

Some states do not allow the exclusion of incidental or consequential damages, or limitations on how long an implied warranty lasts, so the above limitations or exclusions may not apply to you. This warranty gives you specific legal rights, and you may also have other rights which vary from state to state.

## SECTION 5: CUSTOMER RESPONSIBILITIES

The product must exhibit reasonable care, maintenance, operation, storage and general upkeep as written in the maintenance section of the Owner's/Operator's manual. Should an operational problem or failure occur, the product should not be used, but delivered as is to an authorized Husqvarna dealer for evaluation. Proof of purchase, as explained in section 6, rests solely with the customer.

## SECTION 6: PROCEDURE TO OBTAIN WARRANTY CONSIDERATION

It is the Owner's and Dealer's responsibility to make certain that the Warranty Registration Card is properly filled out and mailed to Husqvarna Forest & Garden Company. This card should be mailed within ten (10) days from the date of purchase in order to confirm the warranty and to facilitate post-sale service.

Proof of purchase must be presented to the authorized Husqvarna dealer in order to obtain warranty service. This proof must include date purchased, model number, serial number, and complete name and address of the selling dealer.

To obtain the benefit of this warranty, the product believed to be defective must be delivered to an authorized Husqvarna dealer in a timely manner, no later than thirty (30) days from date of the operational problem or failure. The product must be delivered at the owner's expense. Pick-up and delivery charges are not covered by this warranty. An authorized Husqvarna dealer can be normally located through the "Yellow Pages" of the local telephone directory or by calling 1-800-HUSKY62 for a dealer in your area.

**HUSQVARNA**  
7349 Statesville Road  
Charlotte, NC 28269

531 83 81-23 2002