

# Husqvarna

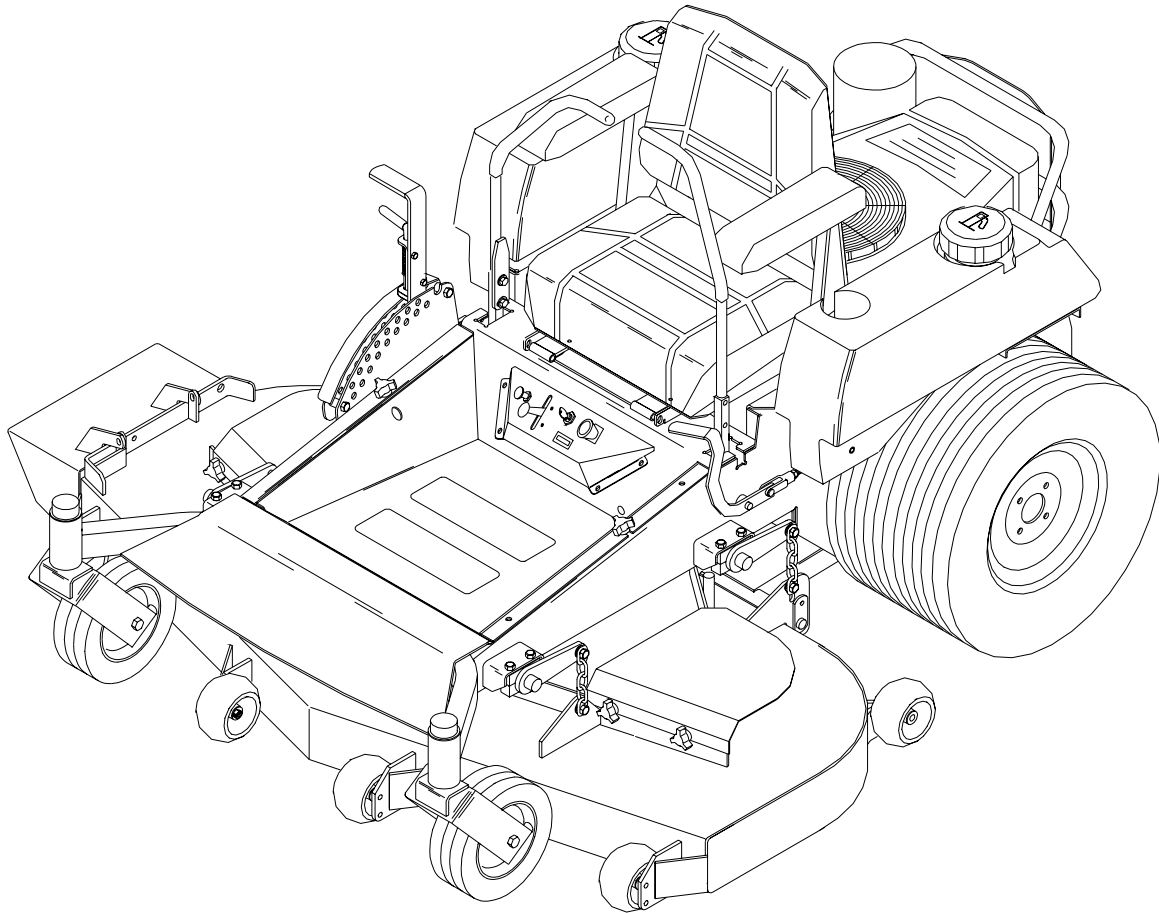

## Operators manual



Please read these instructions carefully and make sure you understand them before using the machine.

## Models:

968999185 / ZTH5225KAA  
968999186 / ZTH6125KAA  
968999189 / ZTH6123KOLA  
968999224 / ZTH6127KOB  
968999225 / ZTH7227KOB

For Serial No. 033600000 & Higher



# CONTENTS

<b>INTRODUCTION</b> .....	4-5	Safety interlock system .....	19
<b>SYMBOLS &amp; DECALS</b> .....	6	Cutter housings .....	19
<b>SAFETY INSTRUCTIONS</b> .....	7	Hardware .....	20
General use and safety rules .....	7-8	Air filter .....	20
Driving on slopes .....	9	Hydraulic system .....	20
Children safety .....	10	Deck belt .....	20
Service safety .....	10-12	Pump belt .....	21
Transportation .....	12	Lubrication .....	21
<b>PRESENTATION</b> .....	13	Tire pressure .....	21
<b>SETUP AND ADJUSTMENTS</b> .....	14	Caster wheels .....	21
Setup .....	14	Fuel filter .....	21
Cutting height .....	14	Winter storage .....	21
Mower deck leveling .....	15	<b>TORQUE SPECIFICATIONS</b> .....	22
Throttle lever tension .....	15	<b>MAINTENANCE SCHEDULE</b> .....	23
Reverse spring detent adj. ....	15	<b>TROUBLE SHOOTING</b> .....	24
Park brake adj. ....	16	<b>WIRING DIAGRAMS</b> .....	25-28
Motion control lever adj. ....	16		
<b>OPERATING INSTRUCTIONS</b> .....	17		
Starting and operation .....	17		
Controls .....	17-18		
<b>MAINTENANCE</b> .....	19		
Engine oil .....	19		
Mower blades .....	19		

# INTRODUCTION

## Introduction

### Congratulations

Thank you for purchasing a Husqvana ride-on mower. This machine is built for the greatest efficiency and rapid mowing of large areas. Convenient controls and a hydrostatic transmission regulated by steering levers also contribute to the machine's performance.

This manual is a valuable document. Following the instructions (use, service, maintenance, etc.) can considerably increase the life-span of your machine and even increase its resale value.

If you sell your machine, be sure to give the operator's manual to the new owner.

The final chapter of this operator's manual comprises a Service Journal. Ensure that service and repair work is documented. A well kept service journal reduces service costs of the season-based maintenance and affects the machine's resale value. Take the operator's manual along when the machine is left at the service center for service.

### General

In this operator's manual, left and right, backward and forward are used in relation to the machine's normal driving direction.

### Driving and Transport on Public Roads

Check applicable road traffic regulations before driving and transporting on public roads. If the machine is transported, you should always use approved fastening equipment and ensure that the machine is well anchored.

### Operating

This machine is constructed only for mowing grass on lawns and other free and even ground without obstacles such as stones, tree stubs, etc. The machine can also be used for other tasks when equipped with special accessories provided by the manufacturer, for which the operating instructions are provided in conjunction with delivery. All other types of use are incorrect. The manufacturer's directions concerning operation, maintenance, and repairs must be carefully followed.

The machine must only be operated, maintained, and repaired by persons that are familiar with the machine's special characteristics and who are well versed in the safety instructions.

Accident prevention regulations, other general safety regulations, occupational safety rules, and traffic regulations must be followed without fail.

Unauthorized modifications to the design of the machine may absolve the manufacturer from liability for any resulting personal injury or property damage.

# INTRODUCTION

## Good Service

Husqvarna's products are sold all over the world and only in specialized retail stores with complete service. This ensures that you as a customer receive only the best support and service. Before the product is delivered, the machine has, for example, been inspected and adjusted by your retailer, see the certificate in the Service Journal in this operator's manual.

When you need spare parts or support in service questions, warranty issues, etc., please consult the following professional:

This Operator's Manual belongs to the machine with manufacturing number:	Engine	Transmission

## Manufacturing Number

The machine's manufacturing number can be found on the printed decal affixed to the left side of the frame under the seat.

- The machine's type designation (I.D.).
- The manufacturer's type number (Model).
- The machine's serial number (Serial no.)

Please state the type designation and serial number when ordering spare parts.

The engine's manufacturing number is stated on a decal. This is placed on the right side on the top of the engine.

- The engine's serial number (E/NO).
- The engine's type designation (Code).

Please state these when ordering spare parts.

The hydraulic pump's manufacturing number is stated on a barcode decal affixed to the left side of the pump housing. The plate states:

- The pump's type designation.
- The pump's serial number.

The hydraulic motor's manufacturing number is stated on a round metal plate. This is placed on the gable inside the motor. The plate states:

- The hydraulic motor's type designation and design version.
- The hydraulic motor's serial number.

# SYMBOLS AND DECALS

## Symbols and Decals

These symbols are found on the machine and in the operator's manual. Study them carefully so that you know what they mean.

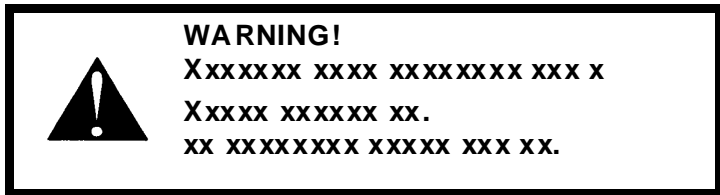

Used in this publication to notify the reader of a risk of **personal injury**, particularly if the reader should neglect to follow instructions given in the manual.

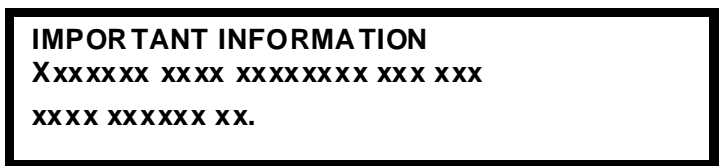

Used in this publication to notify the reader of a risk of **material damage**, particularly if the reader should neglect to follow instructions given in the manual. Used also when there is a potential for misuse or misassembly.



Use on a slope no greater than 10°.



Careful backing up, watch for other people. Careful going forward, watch for other people.

No passengers



Warning! Rotating blades, keep away from the discharge deck



Do not touch rotating parts



Do not stand here

Shut off engine and remove key before performing any maintenance or repair work.

Read Operators Manual.

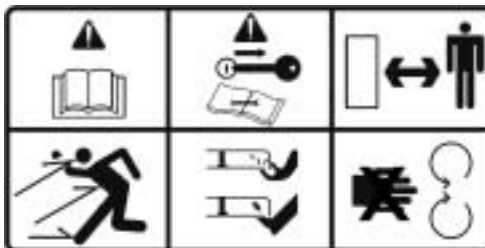

Whole body exposure to thrown objects.

Severing of fingers and toes.

Keep a safe distance from the machine.

Do not open or remove safety shields while engine is running.



Battery acid is corrosive, explosive, and flammable

# SAFETY INSTRUCTIONS

## Safety Instructions

These instructions are for your safety. Read them carefully.



### WARNING!

This symbol means that important safety instructions need to be emphasized. It concerns your safety.

## General Use

- Read all instructions in this operator's manual and on the machine before starting it. Ensure that you understand them and then abide by them.
- Learn how to use the machine and its controls safely and learn how to stop quickly. Also learn to recognize the safety decals.
- Only allow the machine to be used by adults who are familiar with its use.
- Make sure nobody else is in the vicinity of the machine when you start the engine, engage the drive, or run the machine.
- Make sure animals and people maintain a safe distance from the machine.
- Stop the machine if someone enters the work area.
- Clear the area of objects such as stones, toys, steel wire, etc. that may become caught in the blades and thrown out.
- Beware of the discharge deck and do not point it at any one. Do not use the machine without the discharge deck in place.
- Stop the engine and prevent it from starting before you clean the discharge deck.
- Remember that the operator is responsible for dangers or accidents.
- Never take passengers. The machine is only intended for use by one person.
- Always look down and behind before and during reversing maneuvers. Keep a look out for both large and small obstacles.
- Slow down before turning.
- Shut down the blades when not mowing.



8011-512

*Read the operator's manual before starting the machine.*



8011-513

*Clear the area of objects before mowing.*



8011-520

*Never take passengers.*

# SAFETY INSTRUCTIONS

- Be careful when rounding fixed objects, so that the blades do not hit them. Never drive over foreign objects.
- Only use the machine in daylight or in other well-lit conditions. Keep the machine a safe distance from holes or other irregularities in the ground. Pay attention to other possible risks.
- Never use the machine if you are tired, if you have consumed alcohol, or if you are taking other drugs or medication that can affect your vision, judgement, or coordination.
- Beware of traffic when working near or crossing a road.
- Never leave the machine unsupervised with the engine running. Always shut down the blades, pull back the parking brake, stop the engine, and remove the ignition key before leaving the machine.
- Never allow children or other persons not trained in the use of the machine to use or service it. Local laws may regulate the age of the user.



## WARNING!

Engine exhaust and certain vehicle components contain or emit chemicals considered to cause cancer, birth defects, or other reproductive system damage. The engine exhaust contains carbon monoxide, which is colorless, poisonous gas. Do not use the machine in enclosed spaces.



8011-518

*Keep children away from the work area.*



## WARNING!

When using the machine, approved personal protective equipment shall be used. Personal protective equipment cannot eliminate the risk of injury but it will reduce the degree of injury if an accident does happen. Ask your retailer for help in choosing the right equipment.

- Make sure that you have first aid equipment close at hand when using the machine.
- Never use the machine when barefoot. Always wear protective shoes or boots, preferably with steel toecaps.
- Always wear approved protective glasses or a full visor when assembling or driving.
- Never wear loose clothing that can get caught in moving parts.

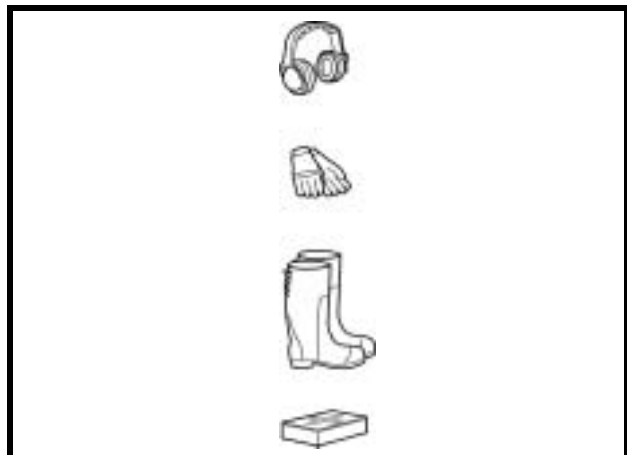

8011-292

*Personal protective equipment.*



# SAFETY INSTRUCTIONS

## Driving on Slopes

Driving on slopes is one of the operations where the risk is greatest that the driver will lose control or the machine will tip over, which can result in serious injury or death. All slopes require extra caution. If you cannot reverse up a slope or if feel unsure, do not mow the slope.

### Do as follows:

- Remove obstacles such as stones, tree branches, etc.
- Mow up and down, not side-to-side.
- Never drive the rider on terrain that slopes more than 10°.
- Avoid starting or stopping on a slope, If the tires begin to slip, shut down the blades and drive slowly down the slope.
- Always drive evenly and slowly on slopes.
- Make no sudden changes in speed or direction.
- Avoid unnecessary turns on slopes, and if it proves necessary, turn slowly and gradually downward, if possible.
- Watch out for and avoid driving over furrows, holes, and bumps. On uneven terrain, the machine can tip more easily. Long grass can hide obstacles.
- Drive slowly. Use small movements of the steering controls.
- Be extra cautious with any additional equipment, which can alter the machine's stability.
- Do not mow near verges, ditches, or banks. The machine can suddenly spin around if a wheel goes over the edge of a drop or ditch, or if an edge gives way.
- Do not mow wet grass. It is slippery, and the tires can lose their grip, so that the machine slides.
- Try not to stabilize the machine by putting a foot on the ground.
- When cleaning the chassis, the machine may never be driven near verges or ditches.

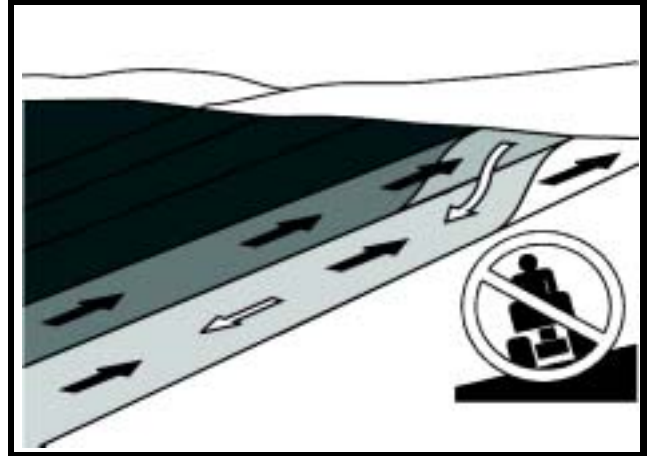

6003-004

*Mow up and down, not side-to-side.*



8011-519

*Be extra cautious when driving on slopes.*

# SAFETY INSTRUCTIONS

## Children:

- Serious accidents may occur if you fail to be on guard for children in the vicinity of the machine. Children are often attracted to the machine and mowing work. Never assume that children will stay put where you last saw them.
- Keep children away from the mowing area and under close supervision by another adult.
- Keep an eye out and shut off the machine if children enter the work area.
- Before and during a reversing maneuver, look backward and downward for small children.
- Never allow a child to ride with you. They can fall off and injure themselves seriously or prevent risk-free maneuvering of the machine.
- Never allow children to operate the machine.
- Be particularly cautious near corners, bushes, trees, or other objects that block your view.

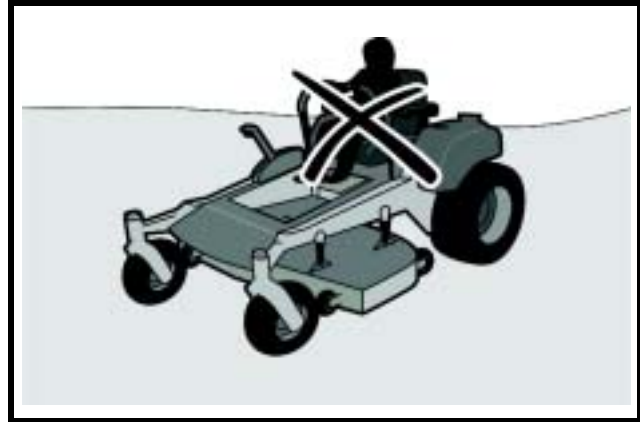

8011-517

*Never allow children to operate the machine.*

## Maintenance:



### **WARNING!**

**The engine must not be started when the driver's floor plate or any protective plate for the mower deck's drive belt is removed.**

- Stop the engine. Prevent the engine from starting by removing the ignition key before making any adjustments or performing maintenance.
- Never fill the fuel tank indoors.
- Fuel and fuel fumes are poisonous and extremely flammable. Be especially cautious when handling fuel, as carelessness can result in personal injury or fire.
- Only store fuel in containers approved for the purpose.
- Never remove the fuel tank cap and never fill the fuel tank while the engine is running.



8011-516

*Never fill the fuel tank indoors.*

# SAFETY INSTRUCTIONS

- Allow the engine to cool before refueling. Do not smoke. Do not fill fuel in the vicinity of sparks or open flames.
- If leaks arise in the fuel system, the engine must not be started until the problem has been resolved.
- Store the machine and fuel in such a way that there is no risk of leaking fuel or fuel vapor leading to damages.
- Check the fuel level before each use and leave space for the fuel to expand, because the heat from the engine and the sun may otherwise cause the fuel to expand and overflow.
- Avoid overfilling. If you spill fuel on the machine, wipe up the spill and wait until it has evaporated before starting the engine. If you have spilled fuel on your clothing, change your clothing.
- Allow the machine to cool before taking any actions in the engine compartment.
- Be very careful when handling battery acid. Acid on skin can cause serious corrosive burns. If you spill battery acid on your skin, rinse immediately with water.
- Acid in the eyes can cause blindness, contact a doctor immediately.
- Be careful when servicing the battery. Explosive gases form in the battery. Never perform maintenance on the battery when smoking or near open flames or sparks. The battery can explode and cause serious injury/damage.
- Ensure that nuts and bolts, especially the fastening bolts for the blade attachments, are properly tightened and that the equipment is in good condition.
- Do not modify safety equipment. Check regularly to be sure it works properly. The machine must not be driven with defective or unmounted protective plates, protective cowlings, safety switches, or other protective devices.
- Do not change the settings of governors and avoid running the engine with overly high engine speed. If you run the engine too fast, you risk damaging the machine components.



## WARNING!

The engine, the exhaust system, and the hydraulic system's components become very warm during operation.  
Risk for burns if touched.



## WARNING!

The battery contains lead and lead compounds, chemicals that are considered to cause cancer, birth defects, and other reproductive system damage.  
Wash your hands after touching the battery.



8011-563

*Do not smoke when performing maintenance on the battery. The battery can explode and cause serious injury/damage.*

# SAFETY INSTRUCTIONS

- Never use the machine indoors or in spaces lacking proper ventilation. The exhaust fumes contain carbon monoxide, and odorless, poisonous, and lethal gas.
- Stop and inspect the equipment if you run over or into anything. If necessary, make repairs before starting.
- Never make adjustments with the engine running.
- The machine is tested and approved only with the equipment originally provided or recommended by the manufacturer.
- The blades are sharp and can cause cuts and gashes. Wrap the blades or use protective gloves when handling them.
- Check the parking brake's functionality regularly. Adjust and service as necessary.
- The mulch deck shall only be used when higher quality mowing is desired in familiar areas.
- Reduce the risk of fire by removing grass, leaves, and other debris that may have accumulated on the machine. Allow the machine to cool before putting it in storage.



8011-515

*Never drive the machine in an enclosed space.*



8011-514

*Clean the machine regularly.*

## Transport:

- The machine is heavy and can cause serious crushing injuries. Be extra cautious when it is loaded on or unloaded from a vehicle or trailer.
- Use an approved trailer to transport the machine. Activate the parking brake, turn off the fuel supply, and fasten the machine with approved fastening devices, such as bands, chains, or ropes, when transporting.
- Check and abide by local traffic regulations before transporting or driving the machine on any road.

### IMPORTANT INFORMATION

**The parking brake is not sufficient to lock the machine in place during transport. Ensure that the machine is well fastened to the transport vehicle. Reverse the machine onto the transport vehicle to avoid tipping it over.**

# PRESENTATION

## Presentation

Thank you for buying a **HUSQVARNA!** Before operating your new mower, read, understand and follow the safety instructions and other directions in this manual.

Lawnmowers and all power equipment, can be potentially dangerous if used improperly. Safety requires good judgement, careful use in accordance with these instructions and common sense.

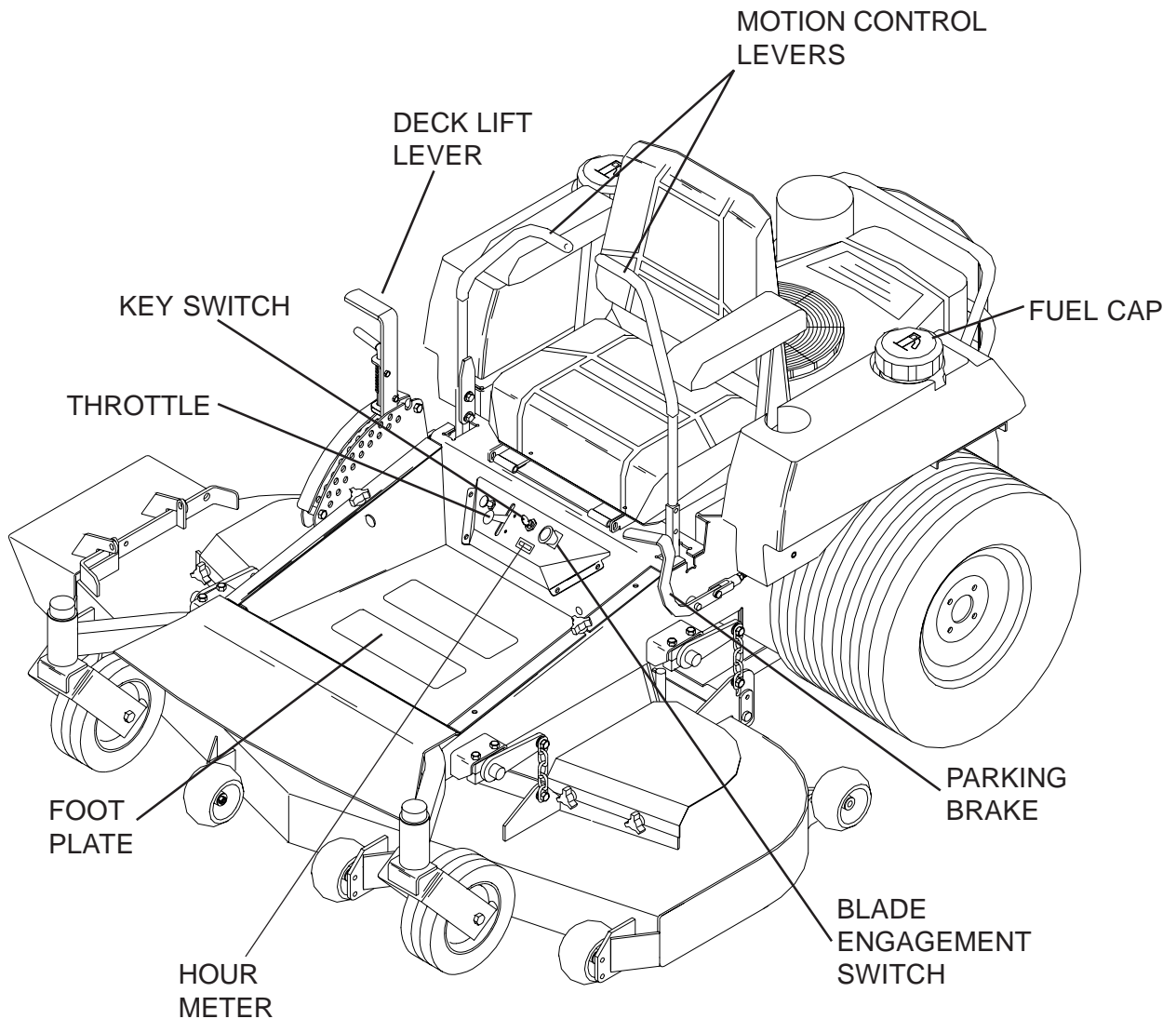

# SETUP AND ADJUSTMENTS

**WARNING:** No settings or adjustments are to be made unless: Engine is stopped, key has been removed, park brake is on and battery cable removed from battery.

## Setup

Uncrate machine.

Mount rear drive wheels using the lug nuts installed on the hubs.

Check the tire pressure in all four tires. All tires should be 15 psi.

Remove top bolt in control arm and loosen bottom bolt, rotate the control levers to the upright position. Align the levers so they are even in the neutral position. Reinstall hardware and tighten. FIG - 3

Install seat rod to the seat frame with cotter pin in plastic bag. Seat rod is located under the seat in the hydraulic pump area.

Check engine oil with dip stick. Add if needed per the engine manufactures specifications. See engine manual for oil type and filling specifications. FIG - 4

Loosen the discharge chute slightly and lower into position. Chute should be snug but still pivot freely.

Install armrests to seat. Hardware and armrests are in the plastic bag.

Assemble the air cleaner hood to the inlet of the air filter, (EFI models only).

## Adjustments

### Cutting Height

Stop the mower and disengage the blades.

Raise the deck height lever to the transport position.

Remove the height adjustment pin and place it in the desired cutting height hole. Lower the lift lever down onto pin. NOTE: Anti-scalp rollers must be in the proper position for maximum deck floatation. See the decal on the front deck for proper settings. FIG - 5

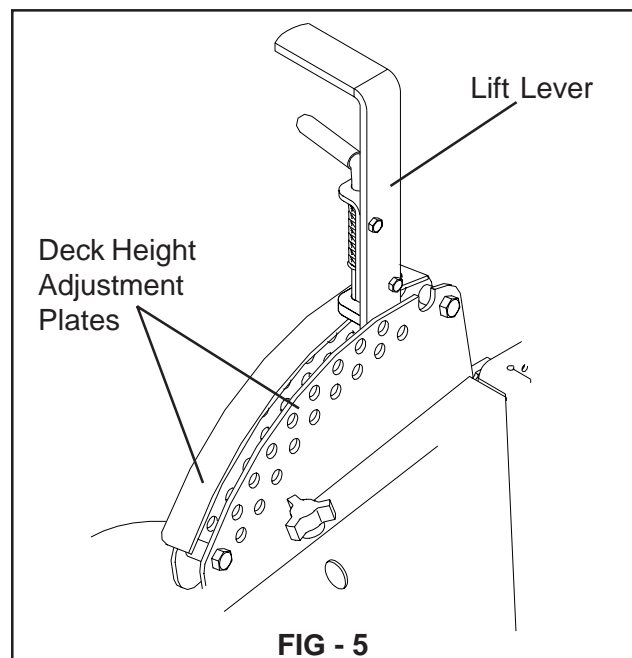
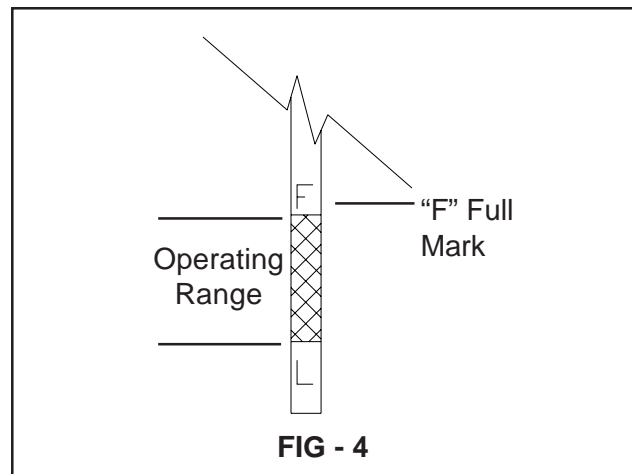
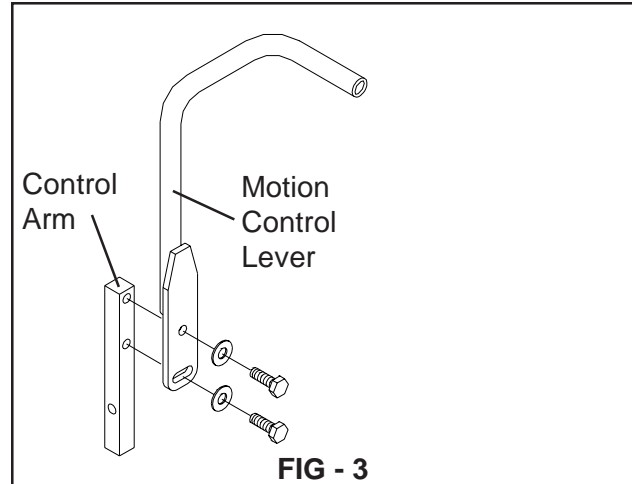

# SETUP AND ADJUSTMENTS

## Mower Deck Leveling

Position machine on a flat surface. Preferably level concrete.

Check the tire pressure in all four tires. Inflation should be 15 psi.

Place 2x4's on edge under the cutting deck from front to rear and lower the deck down onto 2x4's.

Adjust the four lower chain bolts to the center slots on the deck. FIG - 6 NOTE: Make sure the lift blocks under the frame are tightly bolted to the frame.

Check the chains for equal tension. If unequal adjust lower chain bolt in slot.

Place the deck in the 6" cutting height and measure from the cutting edge of the blade to the flat level surface to check the deck cutting height.

## Throttle Lever Tension

Stop engine and remove key.

Throttle lever tension may be adjusted by tightening the pivot bolt. The pivot bolt secures the throttle arm to the mounting bracket which is mounted to the console. Access is gained by removing the console.

## Reverse Spring Detent Adjustment

Stop engine and remove key.

Pull the motion control lever back to the reverse position and release the lever. When the lever stops it should be in line with the neutral slot, so you can move the lever into neutral slot with out hitting the side of the console frame.

If adjustment is required put the seat in the rear most position on the slide, tilt the seat forward, remove the seat rod from seat frame and fold seat over forward onto the frame.

On the back of the console where the spring is fastened, loosen the 3/8" nut and bolt enough to allow the bolt to slide in the slot. FIG - 7

Rotate the motion control lever out into the neutral slot. While the lever is swung out into the neutral slot pull it against the back edge of the neutral slot. Holding the lever adjust the spring by sliding the bolt in the slot to remove all the slop and retighten the bolt.

Check your adjustment by repeating the second step in this process.

If no more adjustment is needed reassemble the seat rod to the seat frame.

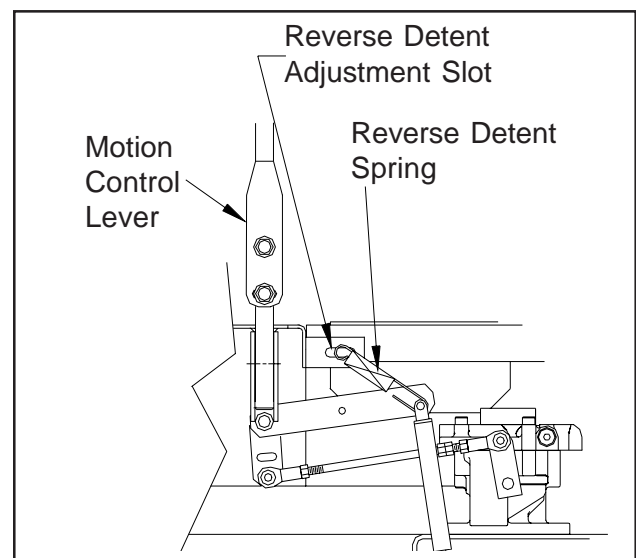
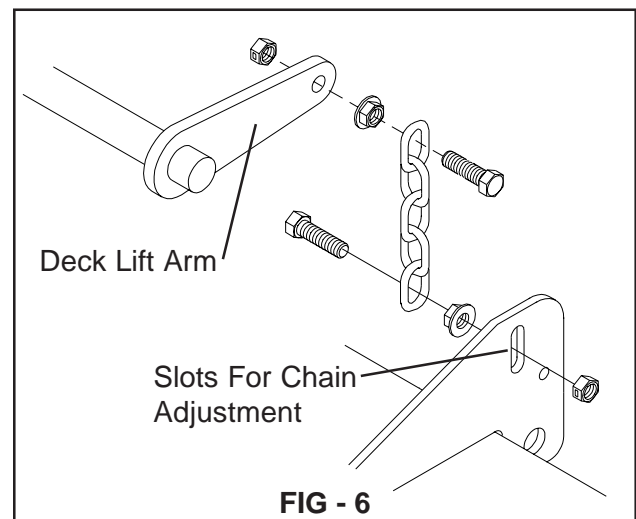

# SETUP AND ADJUSTMENTS

## Park Brake Adjustment

When park brake is in the engaged position the distance between the trunion and the bolt head at the rear of the assembly should measure 1/8" to 1/4" and the spring should measure 1.25". To adjust the gap between the trunion and the bolt head loosen the nut against the yoke then turn the bolt head the proper direction to achieve the proper gap. To adjust the length of the spring turn the nut against the spring the proper direction to lengthen or shorten the spring. This adjustment is the same for both sides. FIG - 8

- If brake lever tries to catch as you engage the brake the spring needs to be tightened. When you change the spring length you also have to maintain the 1/8" to 1/4" gap between the bolt head and the trunion.

NOTE: Do not force the brake lever into the on position if it is catching this will cause damage to the brake assembly.

- If brake squeaks while the machine is in use. The spring may be too tight or the gap between the bolt head and the trunion may be too large.

## Motion Control Linkage Adjustment

This adjustment must be made with the rear wheels rotating. Raise the rear of the machine and block it up so the wheels are free to rotate.

**CAUTION: Keep hands, feet and clothing away from rotating tires.**

Tilt seat forward and remove the seat rod so the seat may rotate forward onto the frame.

Place a 2x4 board between the foot plate and the center of the seat to engage the seat safety switch.

Loosen the nuts directly behind each ball joint on both rods that connect the pump arm to the motion control assemblies. FIG - 9

Start the engine. The park brake must be engaged and the motion control levers in the neutral slots to start the engine. Run the engine approximately half throttle

Release park brake to allow the wheels to rotate.

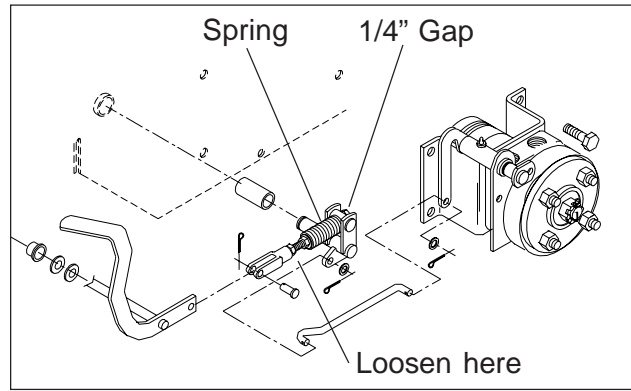

FIG - 8

Begin with either side and put the motion control lever into the neutral position. Adjust the motion control linkage by rotating the double nuts in the proper direction until the wheel stops rotating. FIG - 9 Move the motion control lever forward then into the neutral position and place it into the neutral slot. The wheel must be stopped completely at this point. Now do the same in reverse and release the lever. The lever should return to neutral on its own. If not see reverse spring detent adjustment.

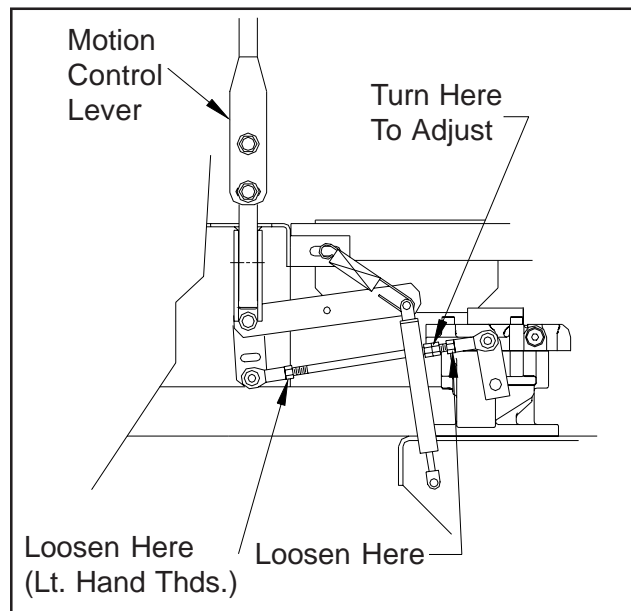

FIG - 9



# OPERATING INSTRUCTIONS

Run engine full throttle to make sure wheels do not rotate. Readjust if any rotation occurs.

Repeat the whole process for the opposite side and tighten the nuts against the ball joints.

Turn machine off.

Reinstall the seat rod and check the wiring harness to the seat safety switch for a good connection and return the seat to the normal position.

## Operating instructions

### Starting and operation

Operator must be sitting in the seat. Engage the park brake, blades disengaged and the motion control levers in the neutral slots.

Set choke (if needed) turn key and release as soon as engine starts. Adjust throttle to half and shut choke off.

Release parking brake.

Close motion control levers.

Engage blades and set RPM to maximum.  
CAUTION: Be sure all persons are clear of the area before engaging blades.

### Controls

Be familiar with all controls their function and how to operate them before starting the machine.

Motion control levers on each side of the console control the direction of movement. See page 7. The left lever controls the flow of oil from the left hydro pump to the left wheel motor. The right lever controls the flow of oil from the right hydro pump to the right wheel motor.

NOTE: To begin motion the operator must be in the seat and the parking brake disengaged before the motion control levers can be moved from the neutral slots or the engine will kill. FIG - 10

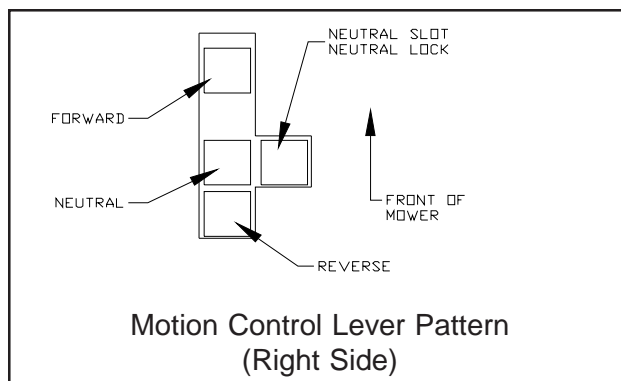

FIG - 10

# OPERATING INSTRUCTIONS

By moving the levers an equal amount forward or back the machine will move in a straight line in that direction. FIG - 11

Movement of either lever forward will cause the right or left wheel to rotate in a forward direction. To stop movement pull both levers into the neutral position.

To turn right while moving in a forward direction pull the right lever back towards the neutral position, this will slow the rotation of the right wheel and cause the machine to turn in that direction.

To turn left while moving in a forward direction pull the left lever back towards the neutral position, this will slow the rotation of the left wheel and cause the machine to turn in that direction.

To zero turn pull one lever back beyond neutral while holding the other slightly ahead of neutral. NOTE: The direction of the zero turn will be determined by which lever is pulled back beyond neutral. Thus left lever back, left zero turn and opposite for right zero turn. **Use extra care when using this maneuver the machine can spin very rapidly if one lever is positioned to far ahead of the other.**

Blade engagement switch located on the console is engaged by pulling up on the switch and pushed down to disengage. FIG - 12

Choke control is located on the console. To choke engine pull knob push to release. FIG - 12

Throttle control is located on the console. Used to control engine RPM. FIG - 12

Parking brake is located on the left side of the machine and directly in front of the fuel tank. Pull the lever back to engage the brake and push lever forward to release the brake.

Key switch is located on the console. Used to start the machine. NOTE: Do not run the starter for more than 5 seconds at a time. If the engine will not start, wait about 10 seconds before trying again. FIG - 12

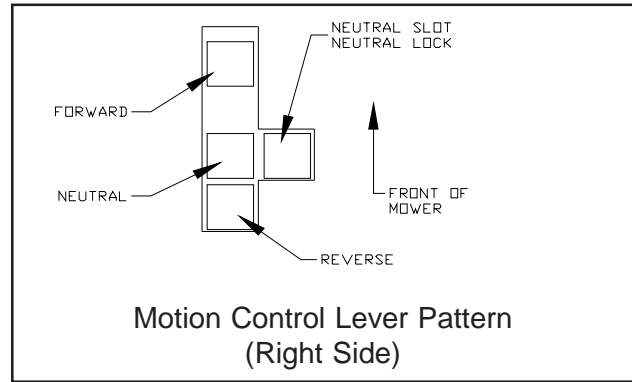

FIG - 11

The hour meter displays the total operating time and reminds of service intervals.

The meter will indicate "CHG OIL" for engine oil and "SVC" for general service at preset intervals.

The hour meter will reset itself at predetermined times.

Engine "CHG" will come on after the first ten (10) hours of operation, and will stay on for one (1) hour of operation before it will reset itself. It will come on every 99 hours thereafter, and stay on for five (5) hours of operation before resetting.

Mower "SVC" message will come on every 50 hours to remind to lubricate the unit, check blades and fasteners, etc. This message will stay on for two (2) hours of operation before resetting.

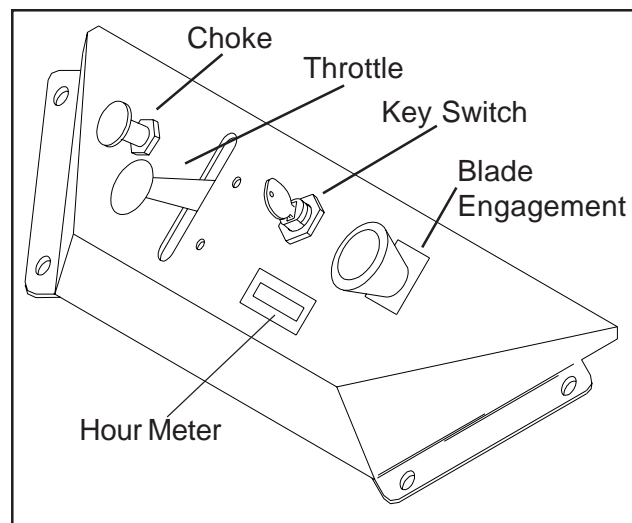

FIG - 12

# MAINTENANCE

Fuel shut off valve is located at the right rear of the seat. The valve has three positions a right tank, left tank and center is the off position. FIG - 13.

Pump release valves located at the right front corner of the pumps. Used to release the system so the machine may be moved by hand when not running. Tilt seat forward to gain access to the pumps. Use a 5/8" wrench to open valve. NOTE: Only rotate valve 1/4 turn to release system.

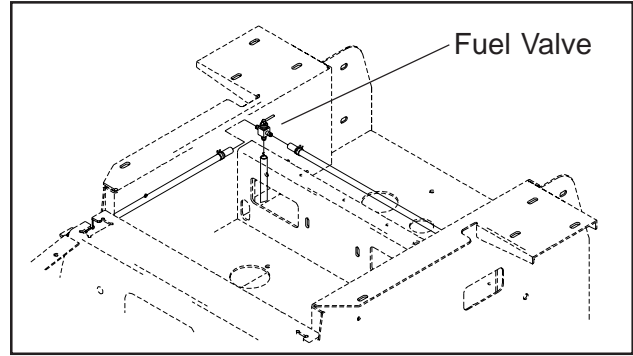

FIG - 13

## Maintenance

**WARNING: No settings, adjustments or maintenance is to be made unless: Engine is stopped, key has been removed, park brake is on and battery cable removed from battery.**

Annual inspection and maintenance from an authorized **Husqvarna** dealer is recommended to keep your machine in the best condition mechanically and ensures safe operation.

### Engine oil

Should be checked daily before starting the machine. See the engine manufacturers manual for specifications on type of oil, filling instructions and service intervals. FIG - 14

### Mower blades

Inspect blades and sharpen or replace as needed. Check blades daily or as needed. Bent, cracked or blades with large notches in them should be replaced. Sharpen to an angle of 22 to 28 degrees. Always check the balance of the blades after sharpening to prevent excessive vibration.

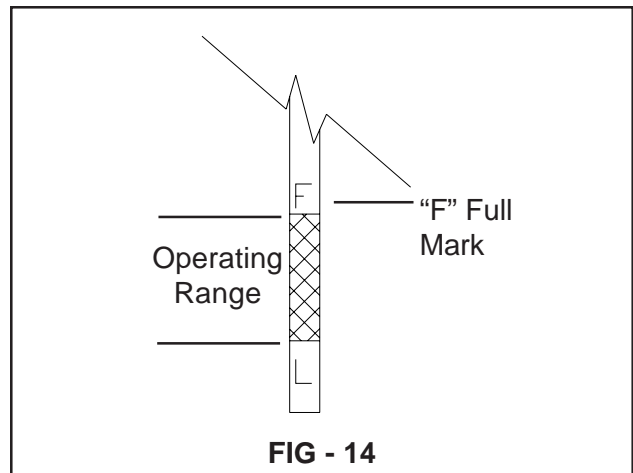

FIG - 14

### Safety interlock system

Check daily and never operate the machine if the system is not functioning properly. The starter should crank only when the operator is in the seat, the parking brake is applied, blade switch off and the motion control levers in the neutral slots. If the machine starts with any of these controls in an operating position, turn the machine off and repair the system immediately.

### Cutter Housings

Grease housings once weekly or every 40 to 50 hours of use. Use a good synthetic grease. Pump grease in until a small amount purges from the popet on the underside of the deck. Check the torque of the pulley bolt (45 ft/lbs) should be maintained.

# MAINTENANCE

## Hardware

Check daily. Inspect the entire machine for loose or missing hardware.

## Air filter

See engine manufacturers specifications for cleaning and replacement intervals.

## Hydraulic system

Check oil level in tank daily. Oil level should be 3/4" to 1" below the top of the tank. Check all fittings, hoses and lines for damage or leaks. Replace or repair any questionable lines or fittings.

Change the oil and filter after the first 250 hours of operation then annually after that. Drain tank and remove filter, be sure to clean around the tank and filter head before removal. Replace filter and drain plug and refill hydraulic tank. Only use MOBIL 1 synthetic oil. FIG - 15

Raise and block up the rear of the machine so the drive wheels can rotate freely. Start the engine at the lowest RPM possible, move the motion control levers forward and run machine for several minutes. Stop engine and recheck the oil level.

If the wheels do not respond an air lock has occurred within the system. The system must be bled off of air or let the machine set overnight to allow the air time to dissipate out of the oil. DO NOT run the machine with an air lock serious damage can occur to the pumps and wheel motors.

## Deck belt

Check every 75 to 100 hours of operation. Check for severe cracking and large nicks. NOTE: The belt will show some small cracks in normal operation.

To replace belt lower the deck to its lowest position. Remove the foot plate and belt shields. Use a ratchet with a 9/16" socket on the spring idler bolt to relieve the tension on the belt. Slide the belt off of pulley and fully remove the belt. Reverse the procedure for installation. See the decal on the top of deck for belt routing information. FIG - 16. After installation is complete check the belt for twists.

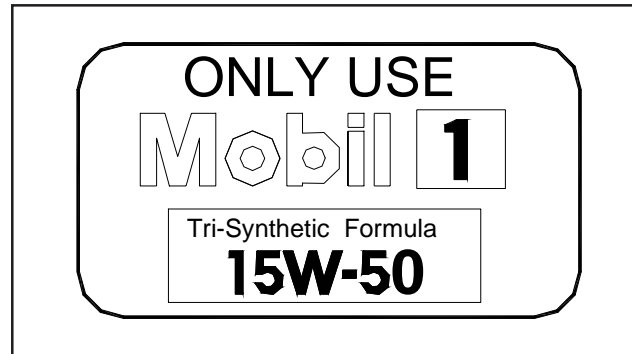

FIG - 15

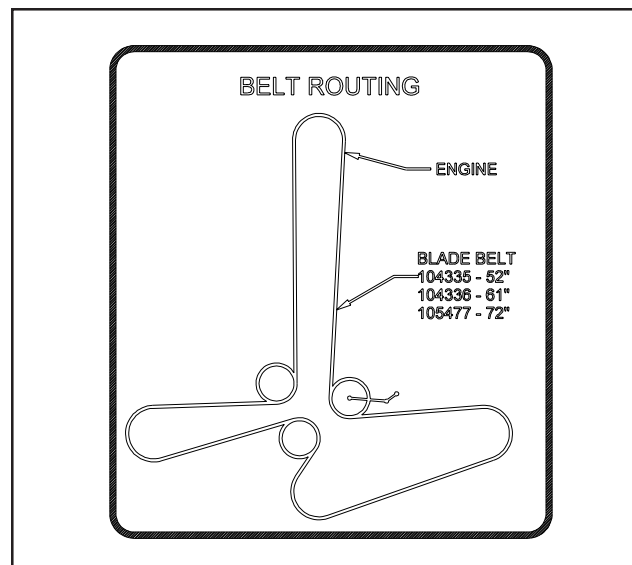

FIG - 16

# MAINTENANCE

## Pump belt

Check belt every 100 hours for excessive wear. To replace belt. Relieve tension on the deck belt and remove deck belt from clutch. See deck belt instructions on previous page. Loosen bolt on the clutch tie down and rotate out of the way. Using a 1/2" drive ratchet inserted into the square hole in the pump idler arm relieve the tension on the pump belt and remove belt. To reinstall belt. Swing pump idler pulley out toward engine to route belt around it. Then route belt around right side pulley first as you are looking up from the underside of machine. Reinstall idler spring and use the ratchet to rotate idler so the belt may be installed all the way around the last pulley.

## Lubrication

See service decal under foot plate for service points and maintenance intervals. Clean grease zerks thoroughly before greasing. See engine manual for engine service. FIG - 17

## Tire pressure

Check every 25 hours. All four tires require 15 psi.

## Caster Wheels

Check every 200 hours. Lift front of unit off of ground so caster wheels can rotate freely. Tighten caster bolt then back off 1/2 turn. Check that wheel rotates freely. If wheel does not rotate freely back the caster bolt off in 1/4 turn increments until wheel rotates freely.

## Fuel filter

Replace every 500 hours or annually. In extremely dirty conditions replacement may need to be at shorter intervals.

## Winter storage

To prepare the machine for storage. Clean the machine, especially under the deck. Touch-up the paint or spray the underside of deck with a light coat of oil.

Inspect the machine for damage and loose hardware.

Change the oil.

Drain the fuel system or add stabilizer to fuel. Make sure to run the machine after to circulate stabilizer throughout system.

Remove the plugs and add 1 tablespoon of oil in each cylinder. Install plugs and crank the engine two or three revolutions.

Grease all zerks.

Remove battery and store inside and protect it from freezing temperatures.

## SERVICE DECAL

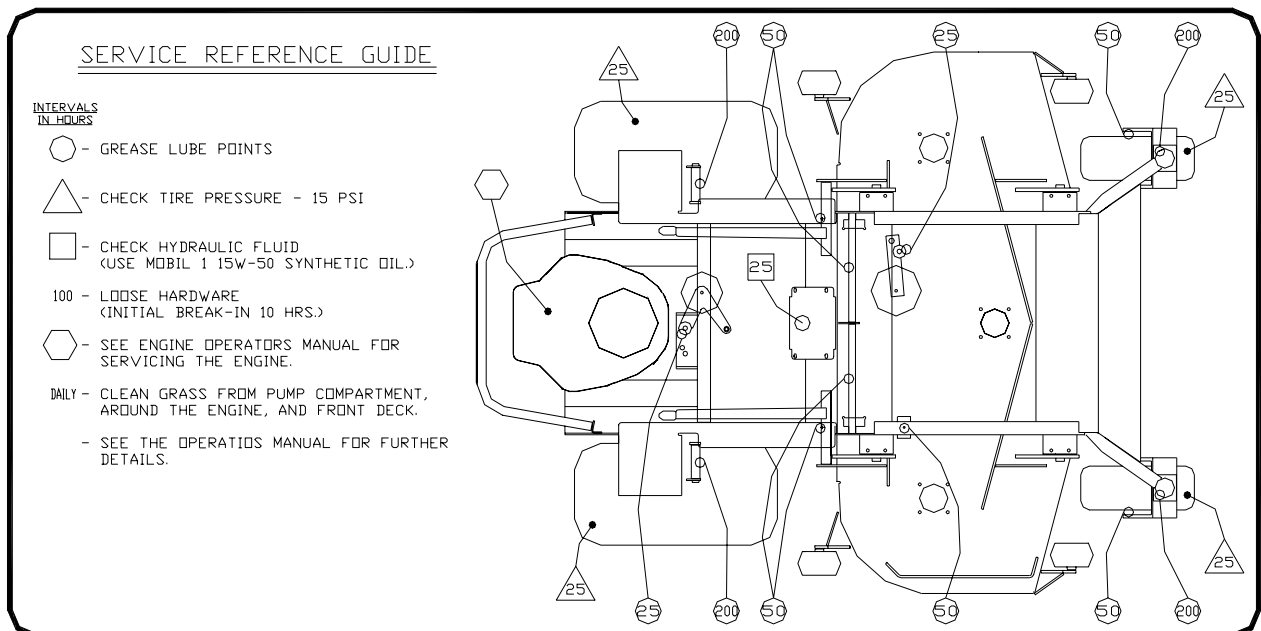

FIG - 17

# MAINTENANCE

## Torque Specifications

·	Engine crankshaft bolt	67 Nm(50 ft/lb)
·	Deck pulley bolts	61 Nm (45 ft/lb)
·	Hydraulic tube nuts	41 Nm (30 ft/lb)
·	Wheel motor hub nut	122 Nm (90 ft/lb)
·	Lug nuts	100 Nm (75 ft/lb)
·	Blade bolt	122 Nm (90 ft/lb)
·	Standard 1/4" fasteners	12 Nm (9 ft/lb)
·	Standard 5/16" fasteners	25 Nm (18 ft/lb)
·	Standard 3/8" fasteners	44 Nm (33 ft/lb)
·	Standard 7/16" fasteners	70 Nm (52 ft/lb)
·	Standard 1/2" fasteners	110 Nm (80 ft/lb)

# MAINTENANCE

## Maintenance Schedule

### For ZTH Riders

Maintenance	Maintenance Interval (hours)						
	Daily	25	50	100	200	250	500
<b>Engine (4)</b>							
Check oil level	X						
Change oil and filter (1)				X			
Clean the air filter's (3)		X					
Replace air filter's (3)				X			
Check for fuel and oil leakage	X						
Clean cooling flanges (3)				X			
Check cooling air inlet	X						
Check fuel pump's air filter	X						
Replace fuel filter				X			
Replace plugs				X			
<b>Hydraulics</b>							
Check oil level	X						
Check for oil leaks	X						
Change hydraulic oil (2)						X	X
Change oil filter (2)						X	X
<b>Electrical</b>							
Check battery	X						
Check the safety system	X						
<b>Lubricate</b>							
Left and right brakes					X		
Left and right motion control shafts			X				
Left and right deck struts			X				
Deck idler arm		X					
Pump idler arm		X					
Caster swivels					X		
Caster tires			X				
Deck lift lever			X				
Throttle cable			X				
Choke cable			X				
Cutter housings			X				
<b>General</b>							
Check bolts and nuts	X						
Check cutting deck		X					
Clean cutting deck (3)	X						
Clean pump compartment (3)	X						
Check tire pressure (15 psi)		X					
Check belts				X			
Check and adjust throttle cable				X			

**Notes:**

1. Change engine oil and filter after first 50 hours and then every 100 hours.
2. Change hydraulic oil and filter after the first 250 hours or season and then every 500 hours.
3. During dusty or dry conditions cleaning and replacement should be more frequent.
4. Refer to engine manual for more information.

# TROUBLE SHOOTING

## PROBLEM

## POSSIBLE CAUSES

---

ENGINE WILL NOT START.	Blade switch on. Drive levers not in the neutral slots. Operator not in seat. Park brake disengaged. Dead battery. Fuel valve closed or in the wrong position. No fuel. Spark plugs defective. Spark plug wires off.
MACHINE WILL NOT MOVE OR MOVES SLOWLY OR HARD.	Park brake on. Pump bypass valves open. Pump drive belt loose or off. Hydraulic system failure. Air in the hydraulic system.
BLADES WILL NOT ENGAGE.	Blade belt off. Clutch unhooked from wiring harness. Blade switch failure or unhooked from harness. Fuse burnt out.
UNEVEN CUT	Tire pressure uneven. Blades bent. Deck chains uneven. Deck lift blocks loose. Anti-scalp rollers set uneven.
CUT IS RAGGED	Blades dull. Ground speed too fast. Grass too long. Grass accumulation under deck.
MACHINE VIBRATION	Blades loose. Blades unbalanced. Engine loose from mounts.

---





# WIRING DIAGRAMS

104414  
CONSOLE HARNESS

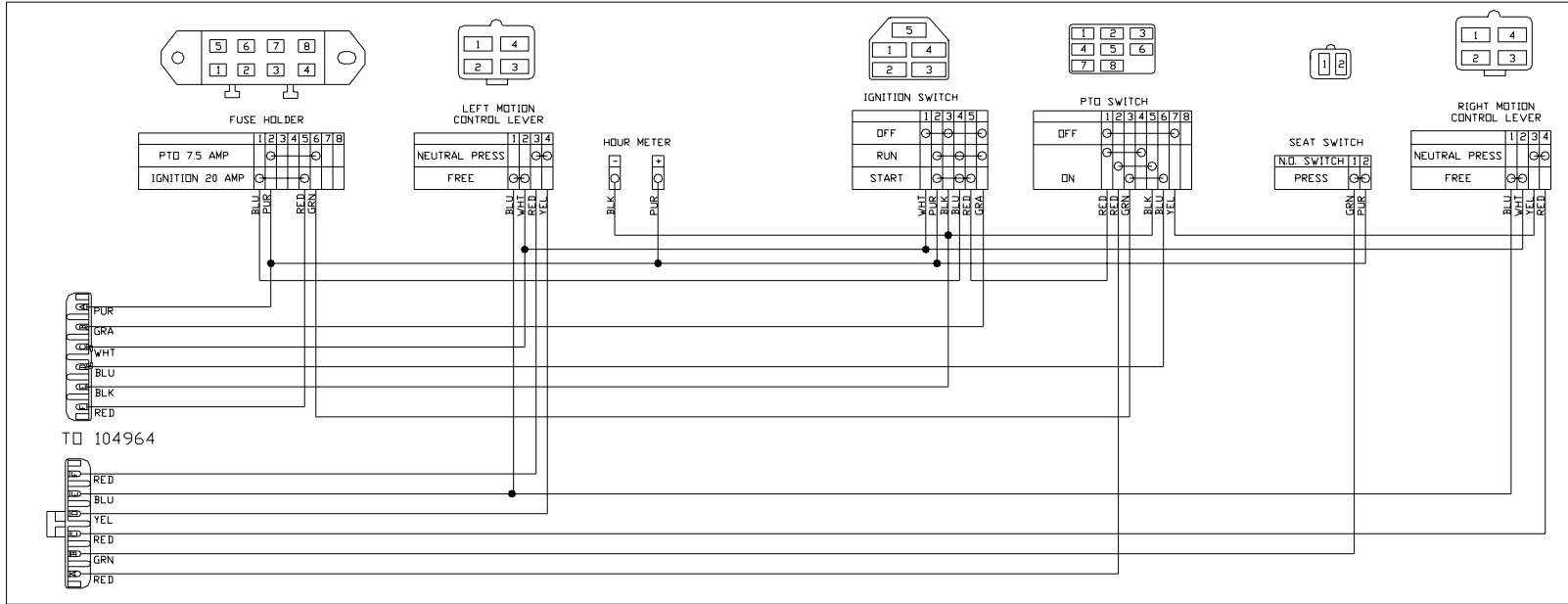

# WIRING DIAGRAMS

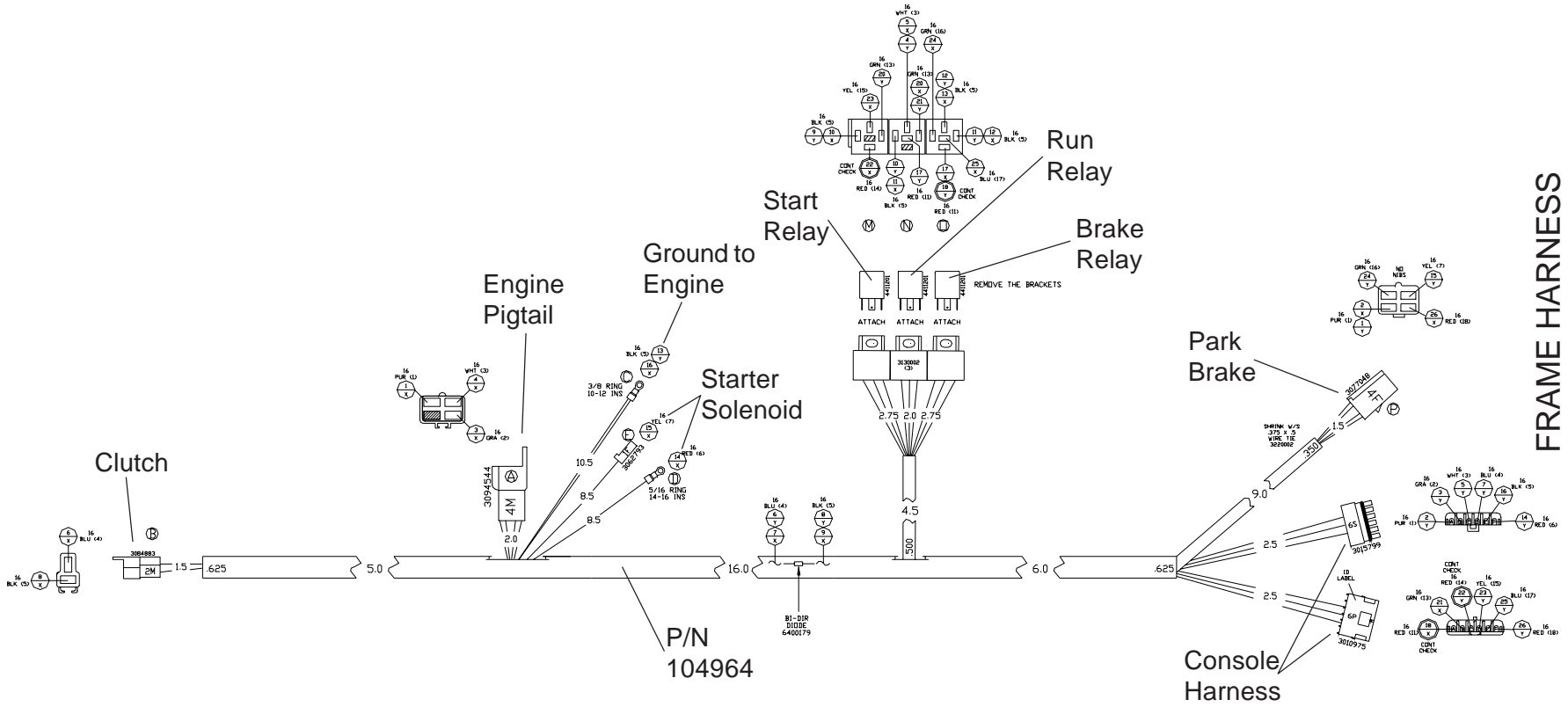

# FRAME HARNESS

# WIRING DIAGRAMS

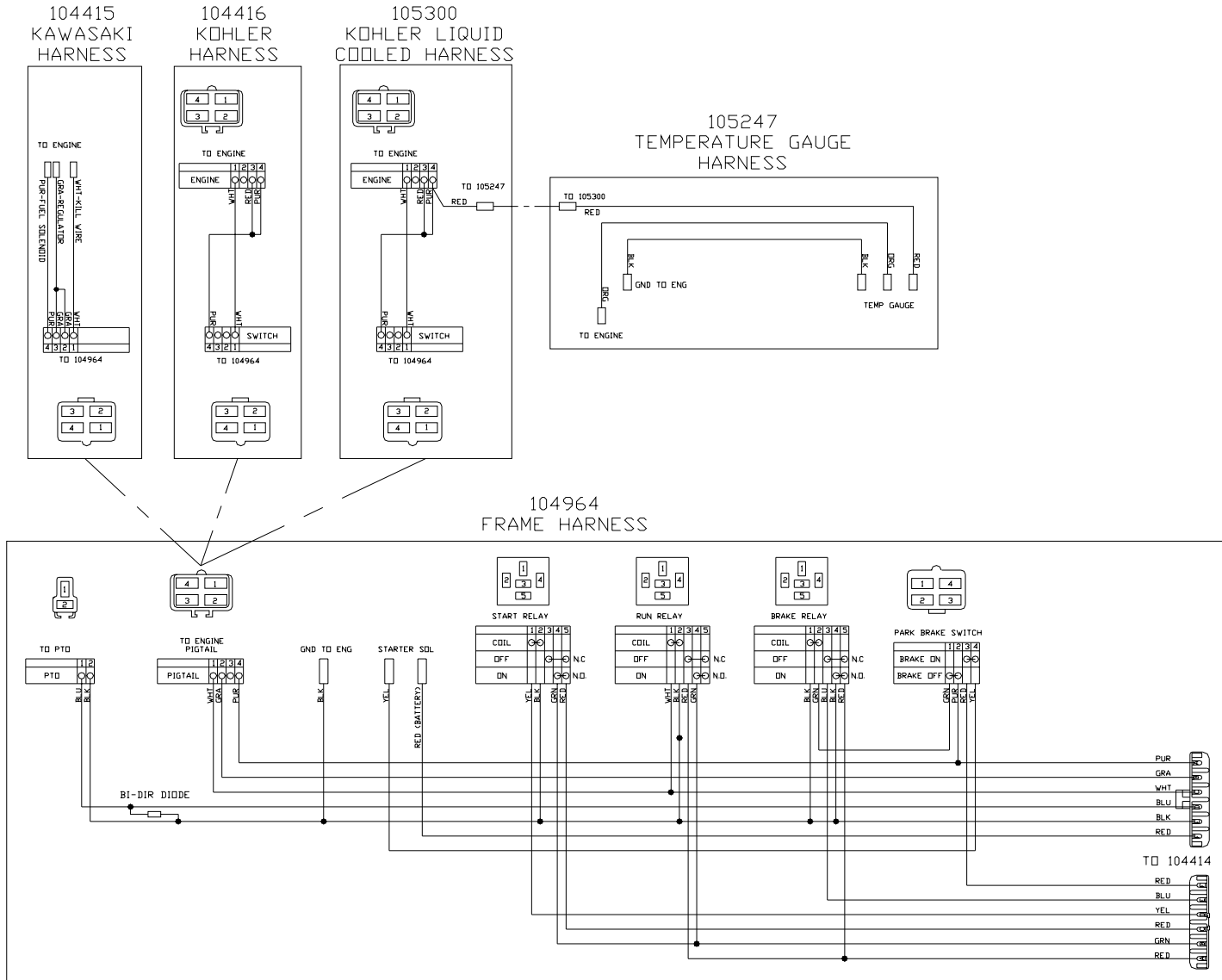

# FRAME HARNESS



 **Husqvarna**