

# LTH1542

**Spare parts**  
**Ersatzteile**  
**Pièces détachées**  
**Reserve onderdelen**  
**Repuestos**  
**Reservdelar**

# TRACTOR - MODEL NO. LTH1542 (HAUB15H42B)

## SCHEMATIC

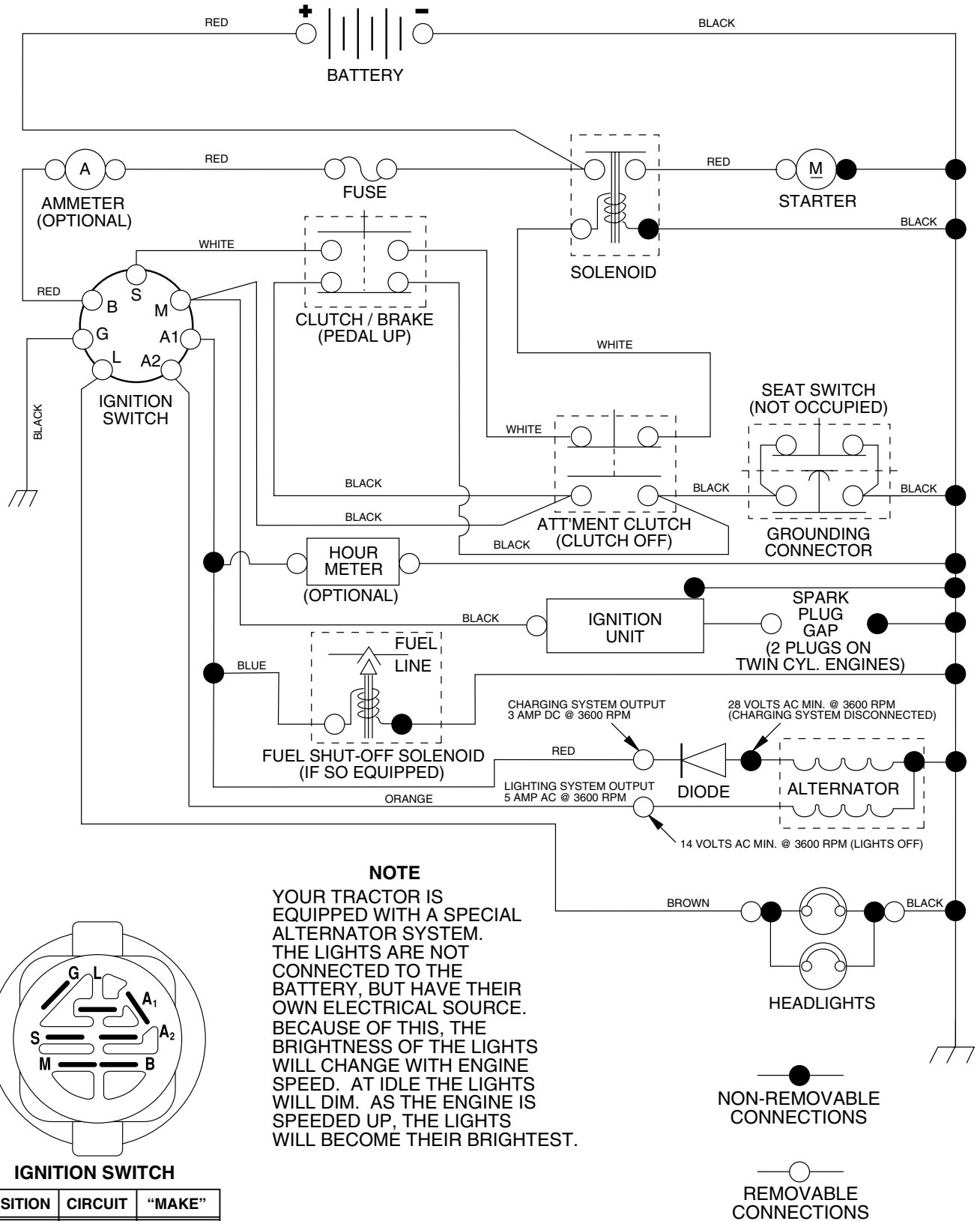

# REPAIR PARTS

TRACTOR - MODEL NO. LTH1542 (HAUB15H42B)

## ELECTRICAL

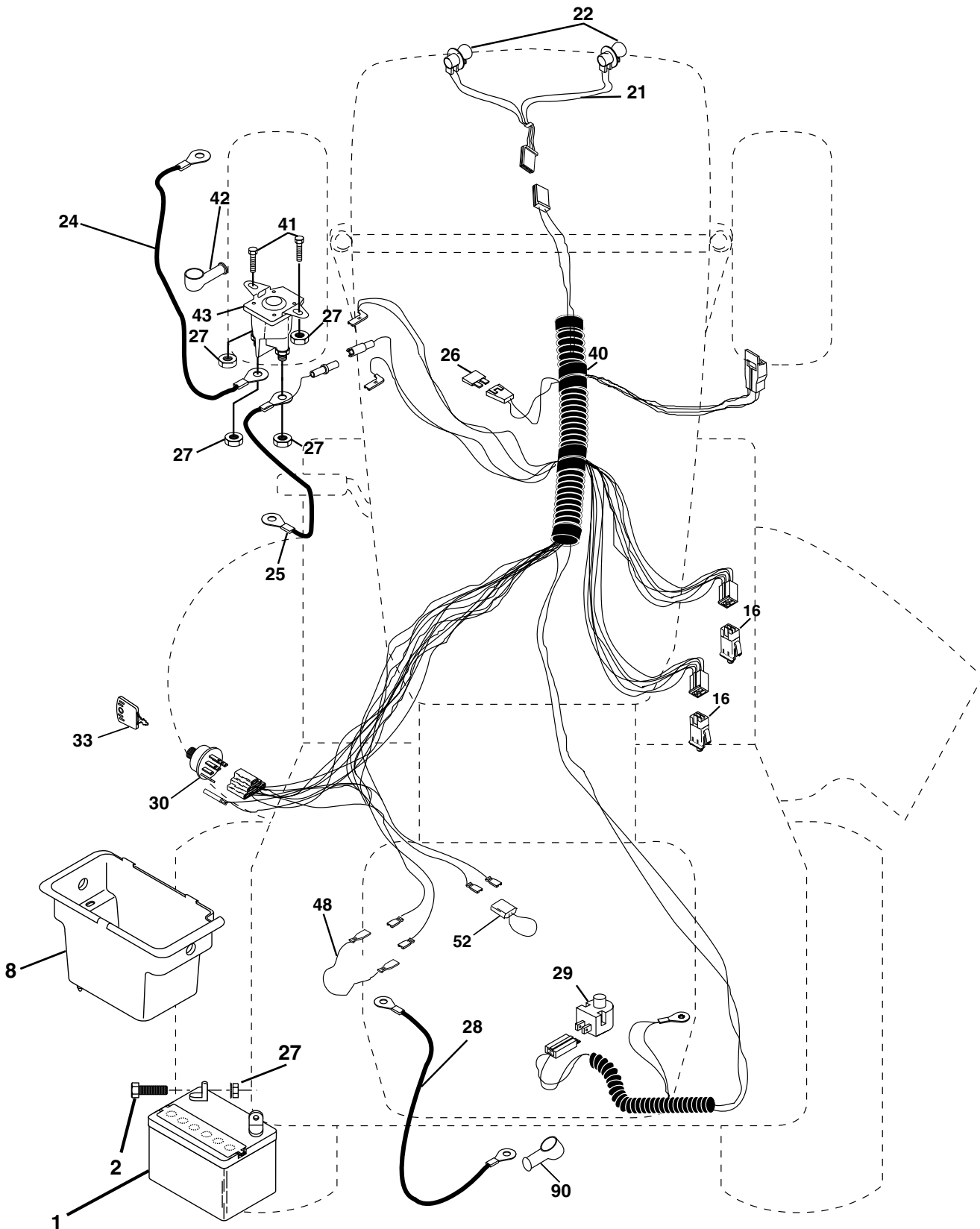

# REPAIR PARTS

## TRACTOR - MODEL NO. LTH1542 (HAUB15H42B)

### ELECTRICAL

KEY NO.	PART NO.	DESCRIPTION
1	532 16 34-65	Battery
2	874 76 04-12	Bolt Hex Hd 1/4-20 Unc x 3/4
8	532 17 66-89	Box Battery
16	532 17 61-38	Switch Interlock
21	532 17 56-85	Harness Asm Light W/4152j
22	532 00 41-52	Bulb Light #1156
24	532 12 47-80	Cable Battery 6 Ga 11" red
25	532 14 61-47	Cable Battery 6 Ga 44" red w/16 wire
26	532 17 51-58	Fuse
27	873 51 04-00	Nut Keps Hex 1/4-20 Unc
28	532 12 47-73	Cable Ground 6 Ga 12" black
29	532 12 13-05	Switch Plunger
30	532 17 55-66	Switch Ign Delta
33	532 14 04-01	Key Ign Molded Generic
40	532 17 97-20	Harness Ign.
41	871 11 04-08	Bolt Blk Fin Hex 1/4 - 20 x 1/2
42	532 13 15-63	Cover Terminal Red
43	532 17 88-61	Solenoid
48	532 14 08-44	Adapter Ammeter Rectangular
52	532 14 19-40	Protection Wire Loop
90	532 18 04-49	Cover Terminal Battery

**NOTE:** All component dimensions given in U.S. inches.  
1 inch = 25.4 mm.

# REPAIR PARTS

## TRACTOR - MODEL NO. LTH1542 (HAUB15H42B)

### CHASSIS AND ENCLOSURES

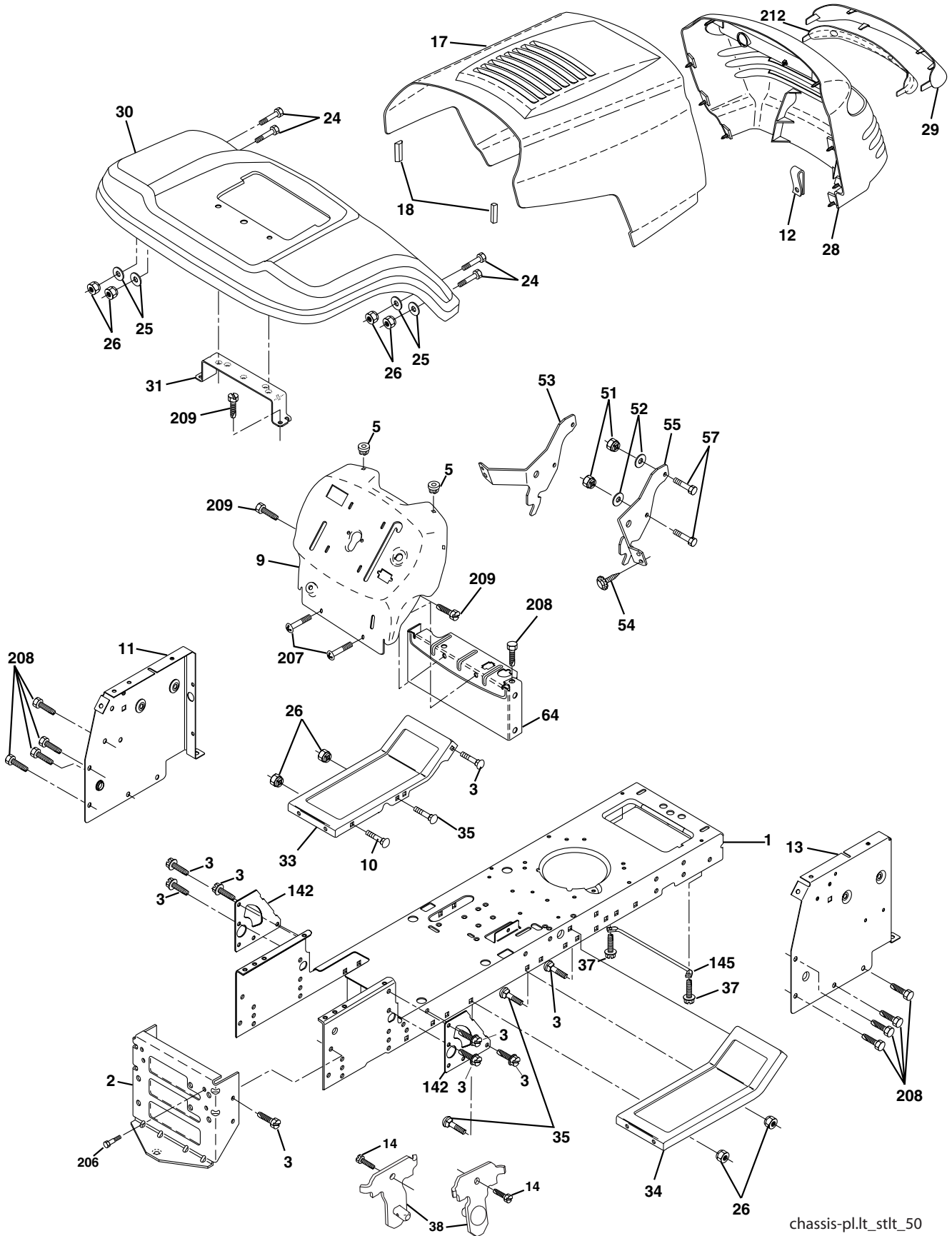

# REPAIR PARTS

## TRACTOR - MODEL NO. LTH1542 (HAUB15H42B)

### CHASSIS AND ENCLOSURES

KEY NO.	PART NO.	DESCRIPTION
1	532 17 46-19	Chassis Stamping
2	532 17 65-54	Drawbar, 12 Ga.
3	817 06 06-12	Screw 3/8-16 x 3/4
5	532 15 52-72	Bumper Hood/Dash
9	532 17 18-53	Dash Silkscr
10	872 14 06-08	Bolt Carriage 3/8-16 x 1
11	532 17 49-96	Panel Dash Lh
12	532 14 56-60	Clip Tinnerman Grille P/L
13	532 18 17-19	Panel Dash Rh
14	817 49 06-08	Screw Thdrol 3/8-16 x 1/2
17	532 16 22-37	Hood LT/PL
18	<b>532 18 49-21</b>	Bumper Hood
24	874 78 06-16	Bolt Fin Hex 3/8-16 Unc x 1 Gr 5
25	819 13 13-12	Washer 13/32 x 13/16 x 12 Ga
26	873 80 06-00	Nut Lock Hex W/Ins 3/8-16 Unc
28	532 17 91-00	Grille/Lens Asm
29	532 16 81-54	Lens P/L
30	532 17 69-53	Fender Footrest LTST Pnt
31	532 13 66-19	Bracket Fender
33	532 18 10-57	Footrest Pnt Lh
34	532 18 10-58	Footrest Pnt Rh
35	872 11 06-06	Bolt Rdhd Sht Sqnk 3/8-16 x 3/4
37	817 49 05-08	Screw Thdrol 6/16-18 x 1/2 TYT
38	532 17 57-10	Bracket Asm Pivot Mower Rear
51	873 80 04-00	Nut Lock W/Insert 1/4-20unc
52	819 09 14-16	Washer 9/32 x 7/8 x 16 Ga.
53	532 14 46-97	Bracket Grille Lh
54	532 16 14-64	Screw Hex Wshd 8-18 x 7/8
55	532 14 46-96	Bracket Grille Rh
57	874 78 04-12	Bolt Hex 1/4-20 x 3/4
58	532 15 01-27	Air Duct Engine P/L
64	532 15 47-98	Dash Lower STLT
142	532 17 57-02	Plate Reinforcement STLT
145	532 15 65-24	Rod Pivot Chassis/Hood
206	532 17 01-65	Bolt Shoulder 5/16-18 TT
207	817 67 05-08	Screw Thdrol 5/16-18 x 1/2
208	817 67 06-08	Screw Thdrol 3/8-16x1/2 Ty-tt
209	<b>817 00 06-12</b>	Screw Hexwsh Thdrl. 3/8-16 x 3/4
212	532 15 62-29	Insert Lens Reflective
--	532 00 54-79	Plug Button

**NOTE:** All component dimensions given in U.S. inches  
1 inch = 25.4 mm

# REPAIR PARTS

## TRACTOR - MODEL NO. LTH1542 (HAUB15H42B)

### DRIVE

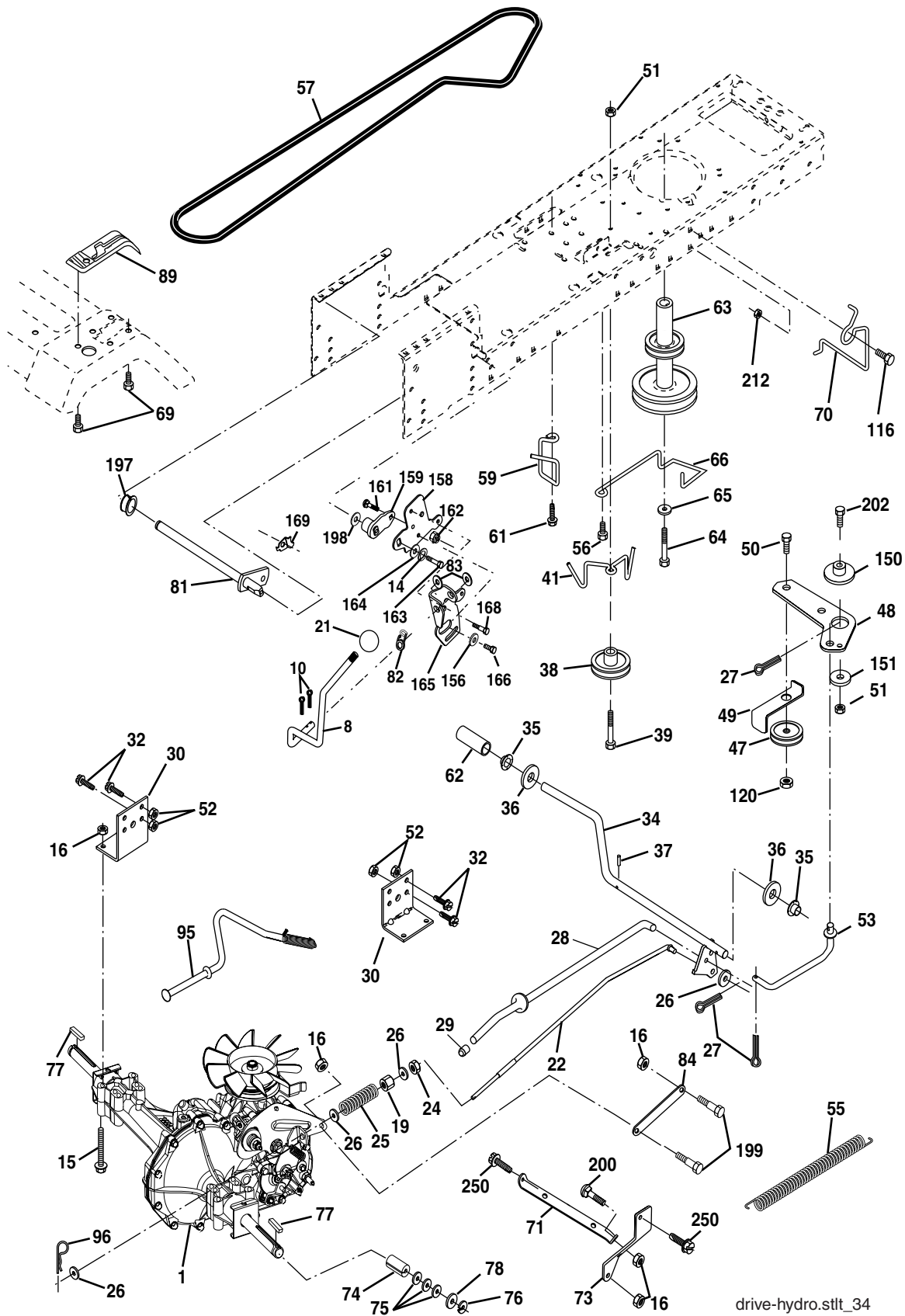

# REPAIR PARTS

## TRACTOR - MODEL NO. LTH1542 (HAUB15H42B)

### DRIVE

KEY NO.	PART NO.	DESCRIPTION	KEY NO.	PART NO.	DESCRIPTION
1	-----	Transaxle Hydro Gr Model 322-0510 (Order parts from transaxle mfg.)	73	532 16 91-82	Strap Torque Rh Hydro
8	532 16 56-19	Rod Shift Fender	74	532 13 70-57	Spacer, Axle
10	876 02 04-16	Pin Cotter 1/8 x 1 CAD	75	532 12 17-49	Washer 25/32 x 1-1/4 x 16 Gauge
14	810 04 04-00	Washer Lock Hvy Helical 1/4	76	812 00 00-01	E-Ring
15	874 49 05-44	Bolt Hex Flg Hd 5/16-18 x Gr.5	77	532 12 35-83	Key, Square
16	873 80 05-00	Nut Lock Hex W/Ins. 5/16-18 Unc P	78	532 12 17-48	Washer 25/32 x 1-5/8 x 16 Gauge
19	873 80 06-00	Nut Lock Hex W/Wsh 3/8-16 Unc	81	532 16 55-96	Shaft Asm. Cross Hydro
21	532 14 08-45	Knob, Deluxe	82	532 12 37-82	Spring Torsion T/A
22	532 16 94-98	Rod, Brake Hydro	83	819 17 12-16	Washer 17/32 x 3/4 x 16 Ga.
24	873 35 06-00	Nut	84	532 16 98-43	Link Transaxle
25	532 10 68-88	Spring, Brake Rod	89	532 17 69-40	Console, Shift
26	819 13 13-16	Washer	95	532 17 02-01	Control Asm Bypass Hydro
27	876 02 04-12	Pin Cotter 1/8 x 3/4 CAD.	96	532 12 47-88	Retainer Spring 1" Zinc/Cad
28	532 17 57-65	Rod, Parking Brake	103	873 94 08-00	Nut Hex Jam Toplock 1/2-20 Unf
29	532 07 16-73	Cap, Parking Brake	116	872 14 06-08	Boulon 3/8-16 x 1
30	532 17 49-73	Bracket, Transaxle	120	873 90 06-00	Nut Lock Flg 3/8-16
32	874 76 05-12	Bolt Hex Hd 5/16-18 Unc x 3/4	150	532 17 54-56	Spacer Retainer
34	532 17 55-78	Shaft, Foot Pedal	151	819 13 32-10	Washer 13/32 x 2 x 10 Ga.
35	532 12 01-83	Bearing, Nylon	156	532 16 60-02	Washer Srrtd 5/16 ID x 1.0 x .125 Tk
36	819 21 16-16	Washer	158	532 16 55-89	Bracket Shift Mount
37	532 12 49-63	Pin, Roll	159	<b>532 18 39-00</b>	Hub Shift
38	532 17 91-14	Pulley, Composite	161	872 14 04-06	Bolt Rdhd Sqnk 1/4-20 x 3/4 Gr. 5
39	874 76 06-48	Bolt	162	873 68 04-00	Nut Crownlock 1/4-20 Unc
41	532 17 55-56	Keeper, Belt Idler	163	874 78 04-16	Bolt Hex Fin 1/4-20 Unc x 1 Gr. 5
47	532 12 77-83	Pulley, Idler, V-Groove	164	819 09 10-10	Washer 5/8 x .281 x 10 Ga
48	532 15 44-07	Bellcrank Clutch Grnd Drv Stl	165	532 16 56-23	Bracket Pivot Lever
49	532 12 32-05	Retainer, Belt	166	532 16 68-80	Screw 5/16-18 x 5/8 TT Yellow
50	872 11 06-12	Bolt	168	532 16 54-92	Bolt Shoulder 5/16-18 x .561 TT
51	873 68 06-00	Nut	169	532 16 55-80	Plate Fastening Cross Shf. STLT/ CRD
52	873 68 05-00	Nut Crownlock 5/16-18	197	532 16 96-13	Nyliner Snap-In 5/8" ID
53	532 10 57-10	Link, Clutch	198	532 16 95-93	Washer Nyl. 7/8 ID x .105"
55	532 10 57-09	Spring, Return, Clutch	199	532 16 96-12	Bolt Shoulder 5/16-18 Unc
56	817 06 06-20	Screw 3/8-16 x 1-1/4	200	872 14 05-08	Bolt Rdhd Sq Neck 5/16-18 Unc x 1
57	532 14 02-94	V-Belt, Ground Drive	202	872 11 06-14	Bolt Carr Sh 3/8-16 x 1-3/4 Gr. 5
59	532 16 96-91	Keeper, Center Span	205	819 17 16-16	Washer 17/32 x 1 x 16 Ga.
61	817 12 06-14	Screw 3/8-16 x .875	212	532 14 52-12	Nut Hex Flg Lock
62	532 12 48-72	Cover, Pedal	250	817 06 06-12	Screw 3/8-16 x 3/4
63	532 17 54-10	Pulley, Clutch Eng			
64	<b>532 17 39-37</b>	Bolt Hex 7/16-20 x 4 Ga. 5			
65	810 04 07-00	Washer			
66	532 15 47-78	Keeper Belt Engine			
69	532 14 24-32	Screw Hex Wsh Hi-Lo 1/4-1/2 Unc			
70	532 13 46-83	Guide Belt Mower Drive RH			
71	532 16 91-83	Strap Torque Lh Hydro			

**NOTE:** All component dimensions give in U.S. inches.  
1 inch = 25.4 mm.



# REPAIR PARTS

## TRACTOR - MODEL NO. LTH1542 (HAUB15H42B)

### STEERING ASSEMBLY

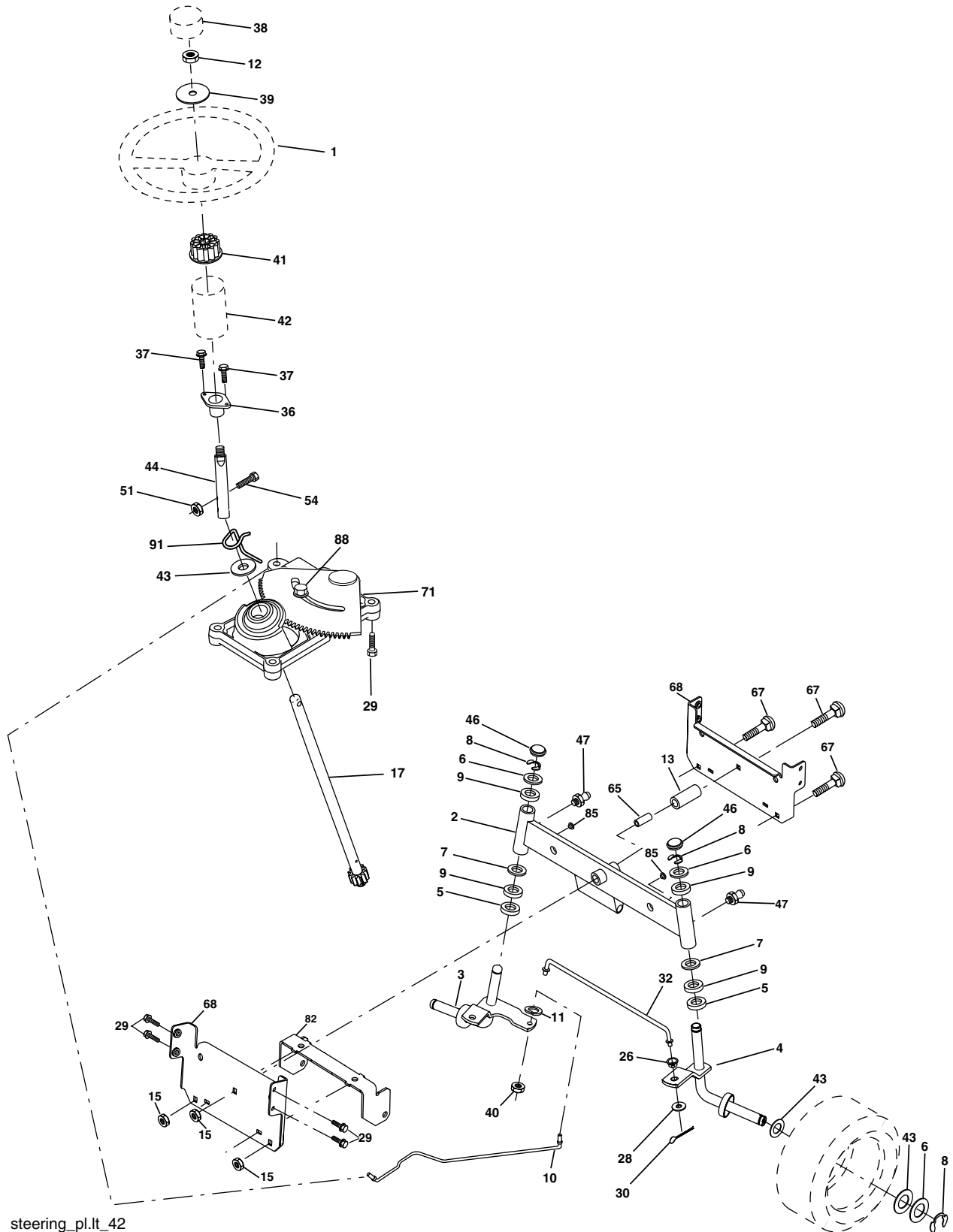

steering\_pl.lt\_42

# REPAIR PARTS

## TRACTOR - MODEL NO. LTH1542 (HAUB15H42B)

### STEERING ASSEMBLY

KEY NO.	PART NO.	DESCRIPTION
1	<b>532 16 66-27</b>	Wheel Steering
2	532 17 51-31	Axle Asm
3	532 16 98-40	Spindle Asm LH
4	532 16 98-39	Spindle Asm RH
5	532 12 49-31	Bearing Race Thrust Harden
6	532 12 17-48	Washer 25/32 x 1-5/8 x 16 Ga
7	819 27 20-16	Washer 27/32 x 1-1/4 x 16 Ga
8	812 00 00-29	Ring Klip #t5304-75
9	532 12 49-37	Bearing Col Strg Blk
10	532 17 51-21	Link Drag
11	810 04 06-00	Washer Lock Hvy Hlcl Spr 3/8
12	873 94 08-00	Nut Hex Jam Toplock 1/2-20 Unf
13	532 13 65-18	Spacer Brg Axle Front
15	532 14 52-12	Nut Hex Flange Lock
17	532 18 06-41	Shaft Asm Strg
26	532 12 68-47	Bushing Link Drag Blk LR
28	819 13 14-16	Washer 13/32 x 7/8 x 16 Ga
29	817 06 06-12	Screw 3/8-16 x 3/4
30	876 02 04-12	Pin Cotter 1/8 x 3/4 Cad
32	532 13 04-65	Rod Tie Wire Form 19 75 Mech
36	532 15 50-99	Bushing Strg
37	532 15 29-27	Screw
38	<b>532 16 66-26</b>	Cap Wheel Steering
39	<b>819 18 24-11</b>	Washer 9/16 ID x 1-1/2 OD x 11 Ga
40	532 12 47-01	Lock nut
41	<b>532 15 99-45</b>	Adaptor Wheel Strg
42	532 16 96-34	Boot Steering Shaft
43	532 12 17-49	Washer 25/32 x 1 1/4 x 16 Ga
44	532 18 06-40	Extension Steering Shaft LR/LT
46	<b>532 17 50-39</b>	Cap Spindle
47	532 18 32-26	Fitting Grease
51	873 54 04-00	Nut Crownlock 1/4-28
54	871 13 04-20	Bolt Hex 1/4-28 Unf x 1-1/4 Ga. 8
65	532 16 03-67	Spacer Brace Axle
67	<b>872 11 06-18</b>	Bolt Rdhd Sq 3/8-16 x 2-1/4
68	532 16 98-27	Axle, Brace
71	532 17 51-46	Steering Asm
82	532 16 98-35	Bracket Susp Chassis Front
85	532 13 38-35	Fastner Christmas Tree
88	532 17 51-18	Bolt Shoulder 7/16-20
91	532 17 55-53	Clip Steering

**NOTE:** All component dimensions given in U.S. inches.  
1 inch = 25.4 mm.

# REPAIR PARTS

## TRACTOR - MODEL NO. LTH1542 (HAUB15H42B)

### SEAT ASSEMBLY

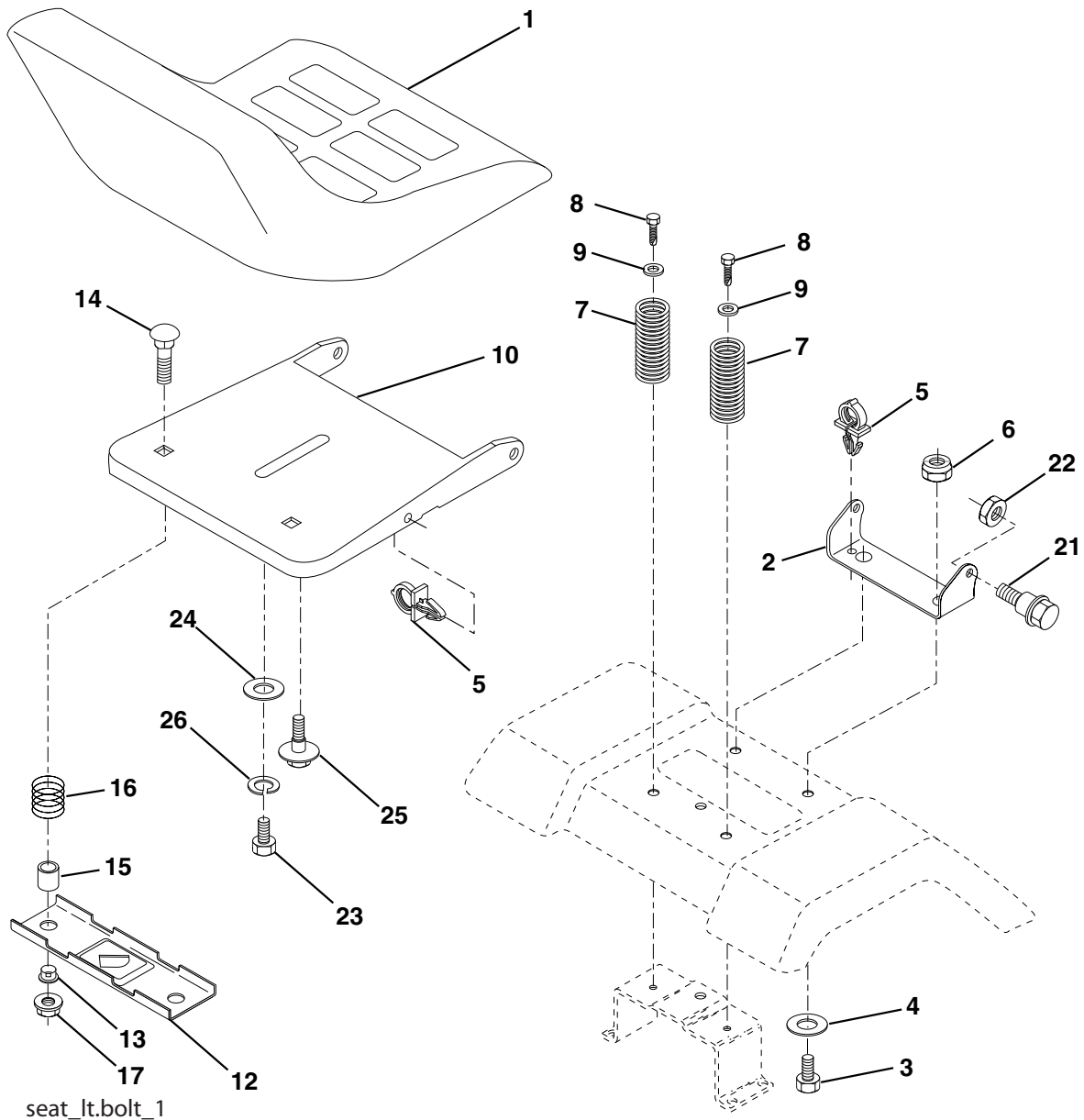

KEY NO.	PART NO.	DESCRIPTION
1	532 14 08-38	Seat
2	532 14 05-51	Bracket Pivot Seat 8 720
3	871 11 06-16	Bolt Fin Hex 3/8-16 Uncx 1
4	819 13 16-10	Washer 13/32 x 1 x 10 Ga
5	532 14 50-06	Clip Push-In
6	873 80 06-00	Nut Hex w/Ins. 3/8-16 Unc
7	532 12 41-81	Spring Seat Cprsn 2 250 Blk Zi
8	817 00 06-16	Screw 3/8-16 x 1
9	819 13 16-14	Washer 13/32 x 1 x 14 Ga.
10	532 18 24-93	Pan Seat
12	532 12 12-46	Bracket Mounting Switch
13	532 12 12-48	Bushing Snap Blk Nyl 50 Id
14	872 05 04-12	Bolt Rdhd Sqnk 1/4-20 x 1-1/2

KEY NO.	PART NO.	DESCRIPTION
15	532 13 43-00	Spacer Split 28 x 96 Yel Zinc
16	532 12 12-50	Spring Cprsn 1 27 Blk Pnt
17	532 12 39-76	Nut Lock 1/4 Lge Flg Gr 5 Zinc
21	532 17 18-52	Bolt Shoulder 5/16-18 Unc-2A
22	873 80 05-00	Nut Hex Lock W/Ins 5/16-18
23	871 11 08-14	Bolt, Hex Black
24	819 17 19-12	Washer 17/32 x 1-3/16 x 12 Ga.
25	532 12 70-18	Bolt Shoulder 5/16-18 x 62
26	810 04 08-00	Washer Lock

**NOTE:** All component dimensions given in U.S. inches.  
1 inch = 25.4 mm

# REPAIR PARTS

## TRACTOR - MODEL NO. LTH1542 (HAUB15H42B)

### DECALS

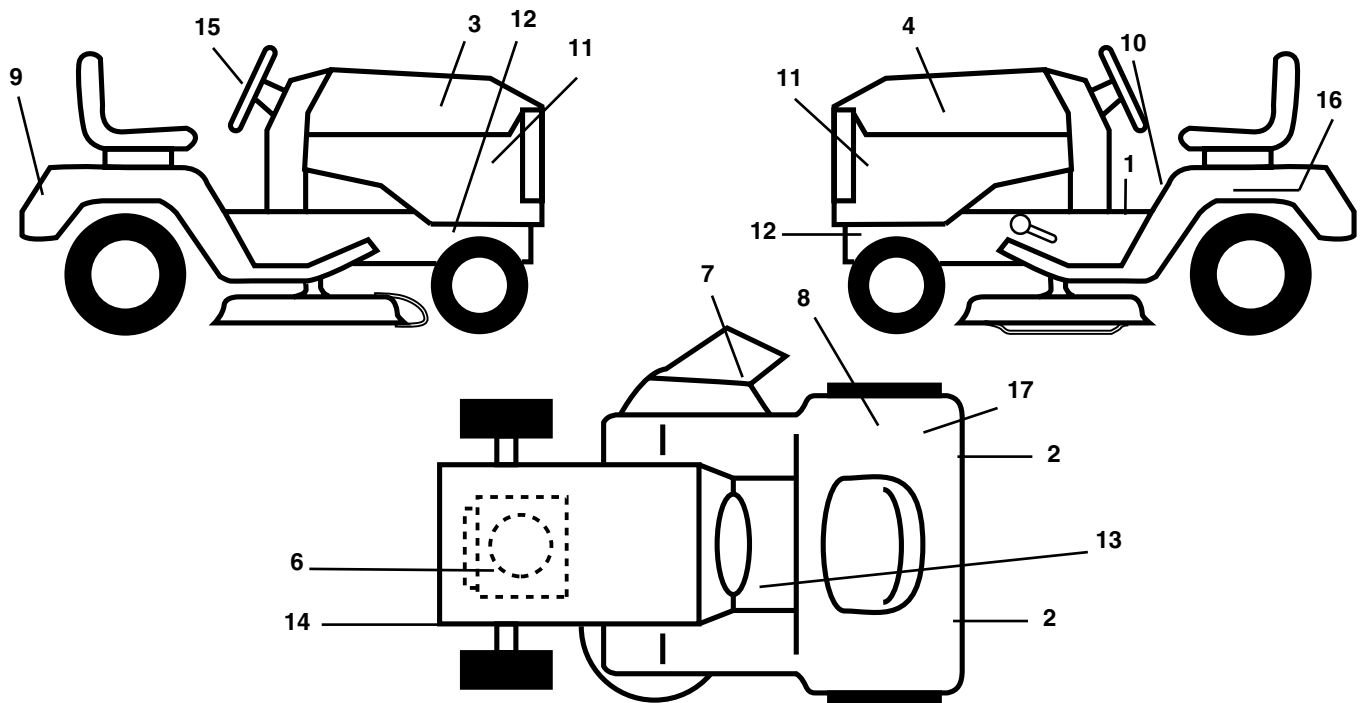

KEY NO.	PART NO.	DESCRIPTION
1	532 14 54-98	Decal Read Owners Manual
2	532 10 62-02	Reflector Tail Light Red/Amber
3	<b>532 18 42-15</b>	Decal Hood RH
4	<b>532 18 42-16</b>	Decal Hood LH
6	532 18 04-34	Decal Engine
7	532 17 91-28	Decal Deck B 42
8	532 16 88-69	Decal Tick Mark
9	532 17 68-22	Decal Fender Husq
10	532 14 08-37	Decal Saddle Brake Parking
11	532 15 97-13	Decal Panel side
12	532 15 97-36	Decal Hot Muffler

KEY NO.	PART NO.	DESCRIPTION
13	532 15 97-37	Decal Brake/Clutch
14	532 16 03-96	Decal V-Belt Schematic
15	532 17 05-64	Decal Wheel Steering
16	532 14 50-05	Decal Bat Dan/Psn
17	532 18 21-66	Decal Cuttinger
--	532 16 25-98	Decal Drawbar Load Limit
--	532 13 83-11	Decal Handle Lft Height Adjust
--	<b>532 16 69-60</b>	Decal Bypass Fender CRD
--	532 18 10-90	Pad Footrest RH
--	532 18 10-91	Pad Footrest LH
--	<b>532 18 78-95</b>	Manual Owner's (English)

### WHEELS & TIRES

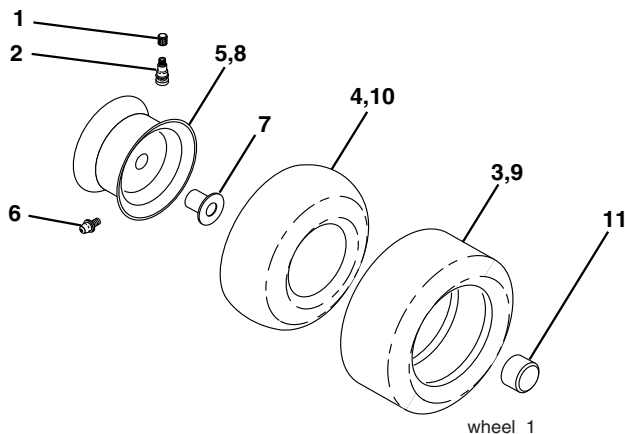

KEY NO.	PART NO.	DESCRIPTION
1	532 05 91-92	Cap Valve Tire
2	532 06 51-39	Stem Valve
3	532 10 62-22	Tire F Ts 15 X 6 0 - 6 Service
4	532 05 99-04	Tube Front (Service Item Only)
5	532 13 83-36	Rim Asm 6"front Silver Service
6	532 12 49-57	Fitting Grease (Front Wheel Only)
7	532 12 49-59	Bearing Flange (Front Wheel Only)
8	532 13 83-37	Rim Asm 8"rear Silver Service
9	532 10 62-68	Tire R Ts 18x9 5-8 C Service
10	532 12 49-26	Tube Rear (Service Item Only)
11	532 17 50-39	Cap Axle Blk 1 50 X 1 00
--	532 14 43-34	Sealant, Tire ( 10 oz. Tube)

**NOTE:** All component dimensions given in U.S. inches  
1 inch = 25.4 mm

# REPAIR PARTS

## TRACTOR - MODEL NO. LTH1542 (HAUB15H42B)

### ENGINE

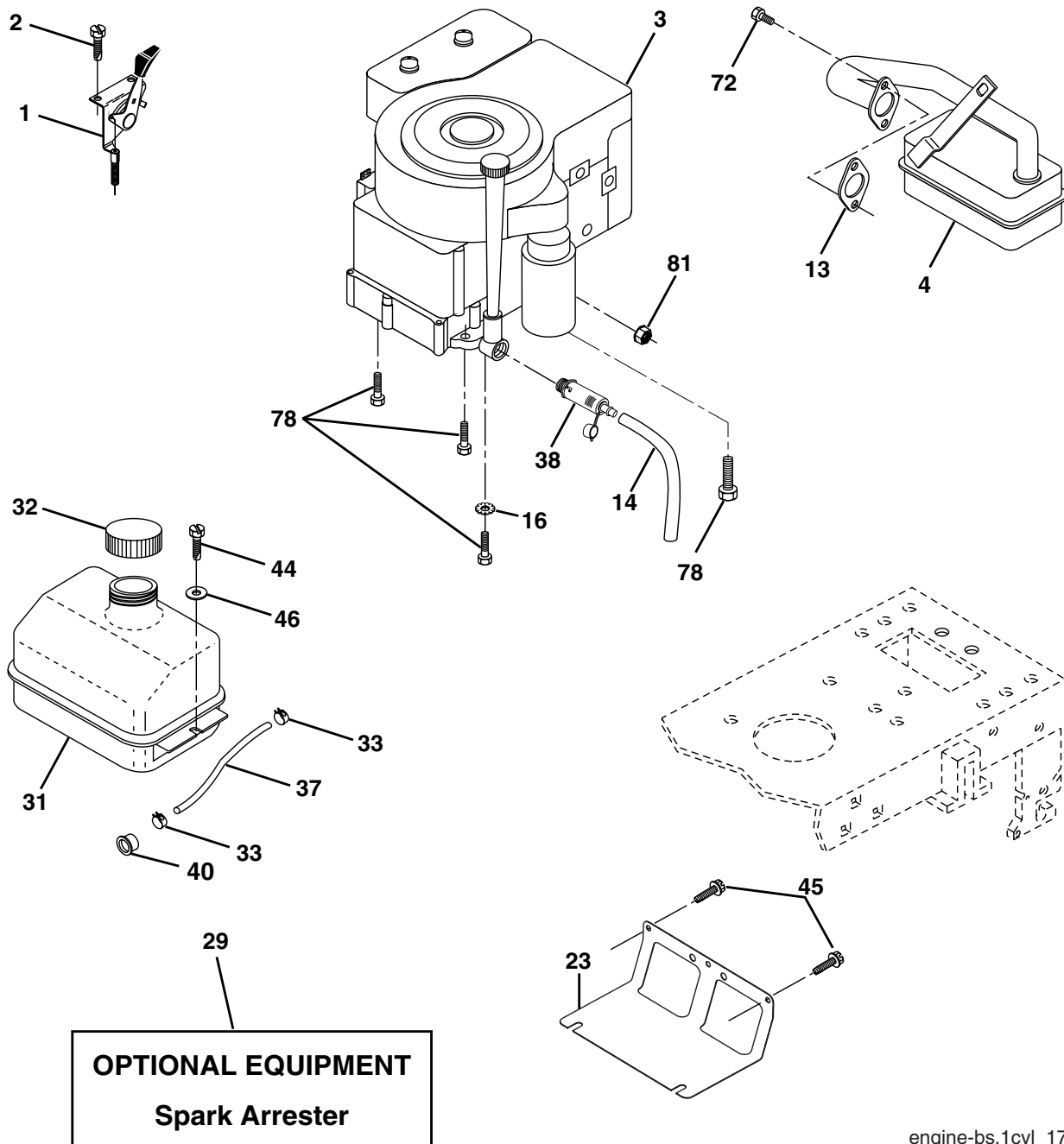

**OPTIONAL EQUIPMENT**  
**Spark Arrester**

engine-bs.1cyl\_17

KEY NO.	PART NO.	DESCRIPTION
1	532 17 05-51	Control Th/ch Flag
2	817 72 04-08	Screw Hex Thd Cut 1/4-20 x 1/2
3	-----	Engine, B&S 31G777(Order parts from engine manufacturer)
4	532 13 73-52	Muffler
13	532 16 52-91	Gasket Eng
14	532 14 84-56	Tube Drain Oil Easy
16	811 05 06-00	Washer Lock Ext Tooth 3/8
23	532 16 98-37	Shield Brn/Dbr Guard
29	532 13 71-80	Kit Spark Arrester (Flat Scrn)
31	<b>532 18 49-00</b>	Tank Fuel Front
32	532 14 05-27	Cap Asm Fuel W/sym Vented

KEY NO.	PART NO.	DESCRIPTION
33	532 12 34-87	Clamp Hose Black
37	532 13 70-40	Line Fuel 20"
38	<b>532 18 16-54</b>	Plug Drain Oil Easy
40	532 12 40-28	Bushing Snap Nyl Blk Fuel Line
44	817 67 04-12	Screw Hexwsh Thdrol 1/4-20 x 3/4
45	817 00 06-12	Screw Hexwsh Thdr 3/8-16 x 3/4
46	819 09 14-16	Washer 9/32 x 7/8 x 16 Ga
72	<b>532 18 39-06</b>	Screw Socket Hd 5/16-18 x 1
78	817 06 06-20	Screw 3/8-16 x 1-1/4
81	873 51 04-00	Nut Keps Hex 1/4-20 Unc

**NOTE:** All component dimensions given in U.S. inches  
1 inch = 25.4 mm

# REPAIR PARTS

TRACTOR - MODEL NO. LTH1542 (HAUB15H42B)

## MOWER LIFT

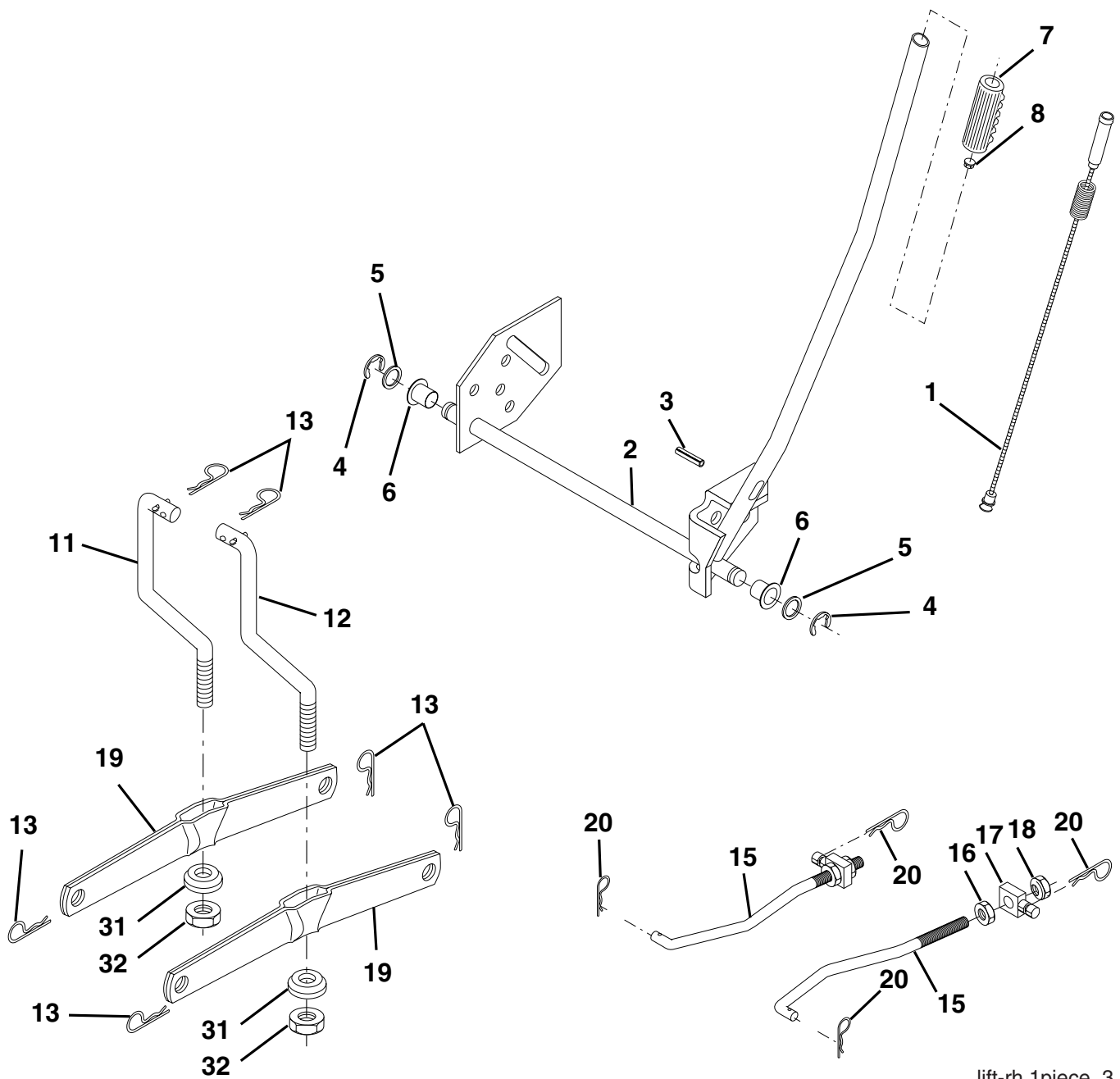

lift-rh.1piece\_3

KEY NO.	PART NO.	DESCRIPTION
1	532 15 94-60	Wire Asm Inner W/plunger LT
2	532 15 94-71	Shaft Asm Lift
3	532 10 57-67	Pin Groove
4	812 00 00-02	E Ring #5133-62
5	819 21 16-21	Washer PLTD 21/32 x 1 x 21ga
6	532 12 01-83	Bearing Nylon Blk 629 Id
7	532 10 94-13	Grip Handle Bicycle
8	532 12 45-26	Button Plunger Black
11	532 13 98-65	Link Lift LH
12	532 13 98-66	Link Lift RH
13	532 12 46-70	Retainer Spring

KEY NO.	PART NO.	DESCRIPTION
15	532 17 32-88	Link Front
16	873 35 08-00	Nut Jam Hex 1/2-13 Unc
17	532 17 56-89	Trunnion
18	873 80 08-00	Nut Lock W/Wsh 1/2-13 Unc
19	532 13 98-68	Arm Suspension Rear
20	532 16 35-52	Spring, Retainer
31	532 16 98-65	Bearing Pvt. Lift
32	873 54 06-00	Nut Crownlock 3/8-24

**NOTE:** All component dimensions given in U.S. inches  
1 inch = 25.4 mm

# REPAIR PARTS

## TRACTOR - MODEL NO. LTH1542 (HAUB15H42B)

### MOWER DECK

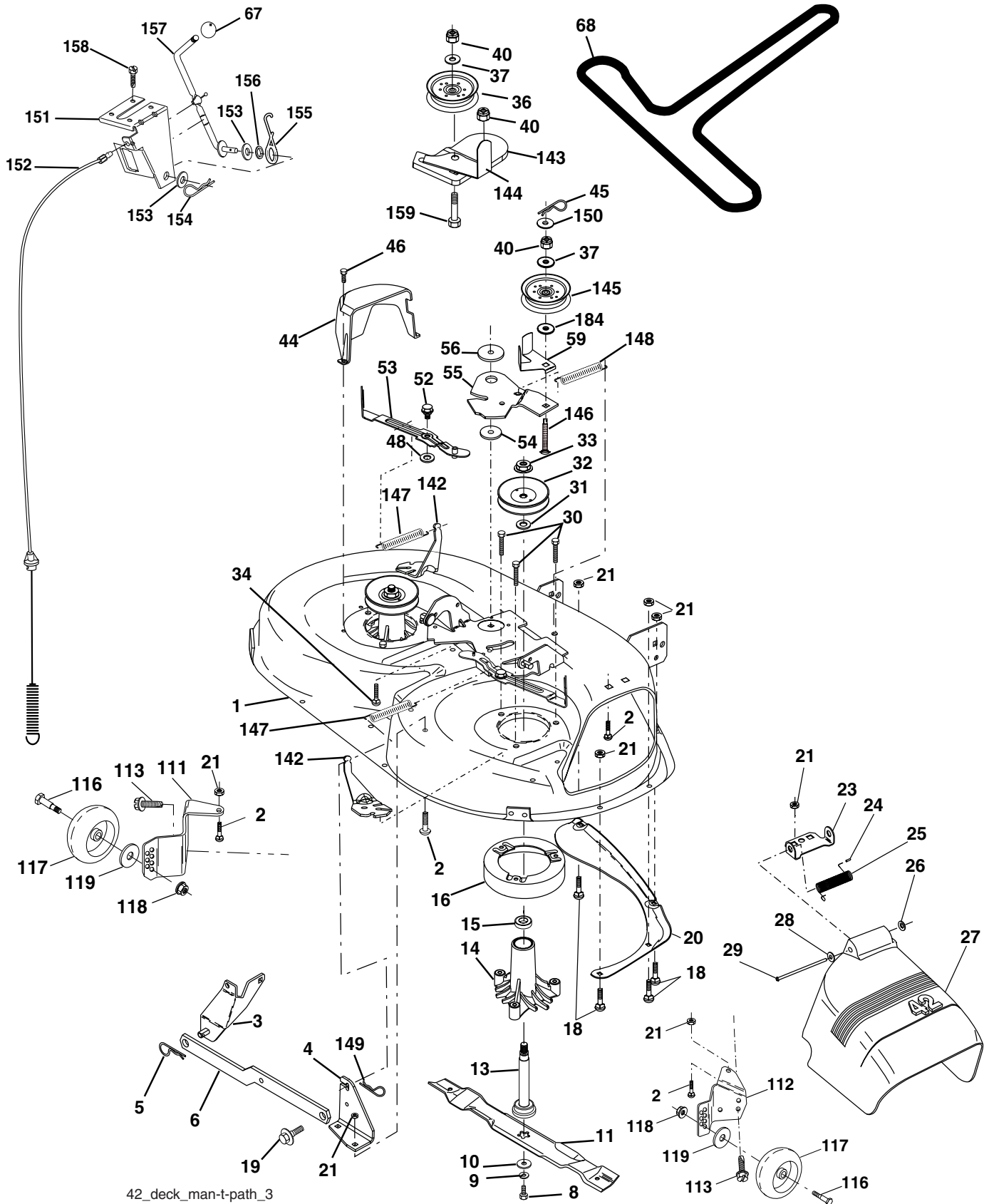

# REPAIR PARTS

## TRACTOR - MODEL NO. LTH1542 (HAUB15H42B)

### MOWER DECK

KEY NO.	PART NO.	DESCRIPTION	KEY NO.	PART NO.	DESCRIPTION
1	532 17 69-22	Deck Asm MWR 42"weldment	54	<b>532 17 85-15</b>	Washer Hardened
2	872 14 05-06	Bolt Rdhd Sqnk 5/16-18 Unc x 3/4	55	532 15 50-46	Arm Idler 42"mower LT/YT
3	532 13 80-17	Bracket Asm Fr Sway Bar 38/42	56	532 12 20-52	Spacer Retainer Mower
4	532 16 54-60	Bracket Asm Deck 42"sway Bar	59	532 17 34-42	Guard TUV Idler
5	532 12 46-70	Retainer Spring	67	532 10 69-32	Knob Rd 3/8-16 Plstc Thds Blk
6	532 17 80-24	Deck Sway Bar	68	532 14 49-59	V-Belt Mower 42"
8	532 85 08-57	Bolt 3/8 - 24 x 1.25 Gr 8	111	532 18 13-92	Bracket Wheel Gauge LH 42" Deck
9	810 03 06-00	Washer Lock Hvy 3/8	112	532 18 13-93	Bracket Gauge Wheel RH 42" Deck
10	532 14 02-96	Washer Hard Blade Mower Vented	113	817 06 05-10	Screw Tapping 3/8-16 x .625
11	<b>532 13 84-91</b>	Blade Mower 42"	116	532 12 48-42	Bolt Shoulder
13	532 13 76-45	Shaft Asm W/lower Bearing	117	532 16 57-46	Wheel Gauge
14	532 12 87-74	Housing Mandrel Vented	118	873 93 06-00	Nut Centerlock 3/8-16 Unc
15	532 11 04-85	Bearing Ball Mandrel	119	819 12 14-14	Washer 3/8 x 7/8 x 14 Ga.
16	532 17 44-93	Stripper Mower	142	532 16 58-90	Arm Spring Brake Mower
18	872 14 05-05	Bolt Rdhd Sqnk 5/16-18 x 5/8	143	532 15 71-09	Bracket Arm Idler 42"
19	532 13 28-27	Bolt Shoulder	144	532 17 34-41	Keeper Belt 42" Clutch
20	532 15 97-70	Baffle Vortex 42	145	532 17 34-37	Pulley Idler Flat
21	<b>873 68 05-00</b>	Nut 5/16-18 Unc	146	532 17 34-43	Bolt Carriage Idler
23	532 17 75-63	Bracket Deflector Mower 42"	147	532 13 13-35	Spring Extension
24	532 10 53-04	Cap Sleeve 80x 112 Blk Mower	148	532 16 90-22	Spring Return Idler
25	532 12 37-13	Spring Torsion Deflector 2 52	149	532 16 58-98	Retainer Spring Yellow
26	532 11 04-52	Nut Push Phos & Oil	150	819 09 12-16	Washer 9/32 x 3/4 x 16 Ga.
27	532 17 18-59	Shield Deflector Mower 42" Blk	151	532 16 96-70	Bracket Clutch Cable
28	819 11 10-16	Washer 11/32 x 5/8 x 16 Ga	152	532 16 96-76	Clutch Cable 42"
29	532 13 14-91	Rod Hinge 42"6 75 Wlg	153	532 16 96-74	Washer Flat 3/8" Type B
30	532 17 39-84	Screw Thd Rolling	154	532 16 96-75	Spring Retainer
31	532 12 99-63	Washer Spacer Mower Vented	155	532 16 96-71	Spring Retention Lvr Cltch Cab
32	532 17 34-36	Pulley Mandrel 42"	156	532 16 96-72	Spacer Clutch Cable
33	532 17 83-42	Nut Toplock Flng	157	532 16 96-69	Rod Clutch Cable 3/8"
34	872 11 06-14	Bolt Rdhd 3/8-16 Unc x 1-3/4 Gr5	158	817 72 04-08	Screw Hex Thd Cut 1/4-20 x 1/2
36	532 17 34-38	Pulley Idler Flat 3 060	159	872 14 06-14	Bolt Rdhd Sqn 3/8-16 Unc x 1-3/4
37	819 13 13-16	Washer 13/32 x 13/16 x 16	184	<b>819 13 14-10</b>	Washer 13/32 x 7/8 x 10 Ga.
40	873 68 06-00	Nut Crownlock 3/8-16 Unc	--	532 13 07-94	Mandrel Assembly(Includes Housing, Shaft and Shaft Hardware Only-Pulley not Included)
44	532 14 00-88	Guard Mandrel LH Black	--	532 17 66-34	Replacement Mower, Complete
45	532 12 47-88	Spring Retainer 1" Zinc/cad			
46	532 13 77-29	Screw Hex Thd Cut 1/4-20 x 5/8 T			
48	532 13 39-44	Washer Hardened Smaller			
52	532 13 98-88	Bolt Shoulder 5/16-18 Unc Blkz			
53	<b>532 18 49-07</b>	Arm Pad Brake			

**NOTE:** All component dimensions given in U.S. inches  
1 inch = 25.4 mm