

YTH1542XP

Spare parts
Ersatzteile
Pièces détachées
Reserve onderdelen
Repuestos
Reservdelar

TRACTOR - MODEL NO. YTH1542XP (HAU15H42E)

SCHEMATIC

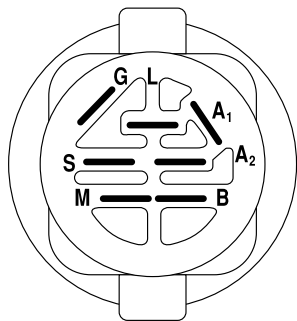
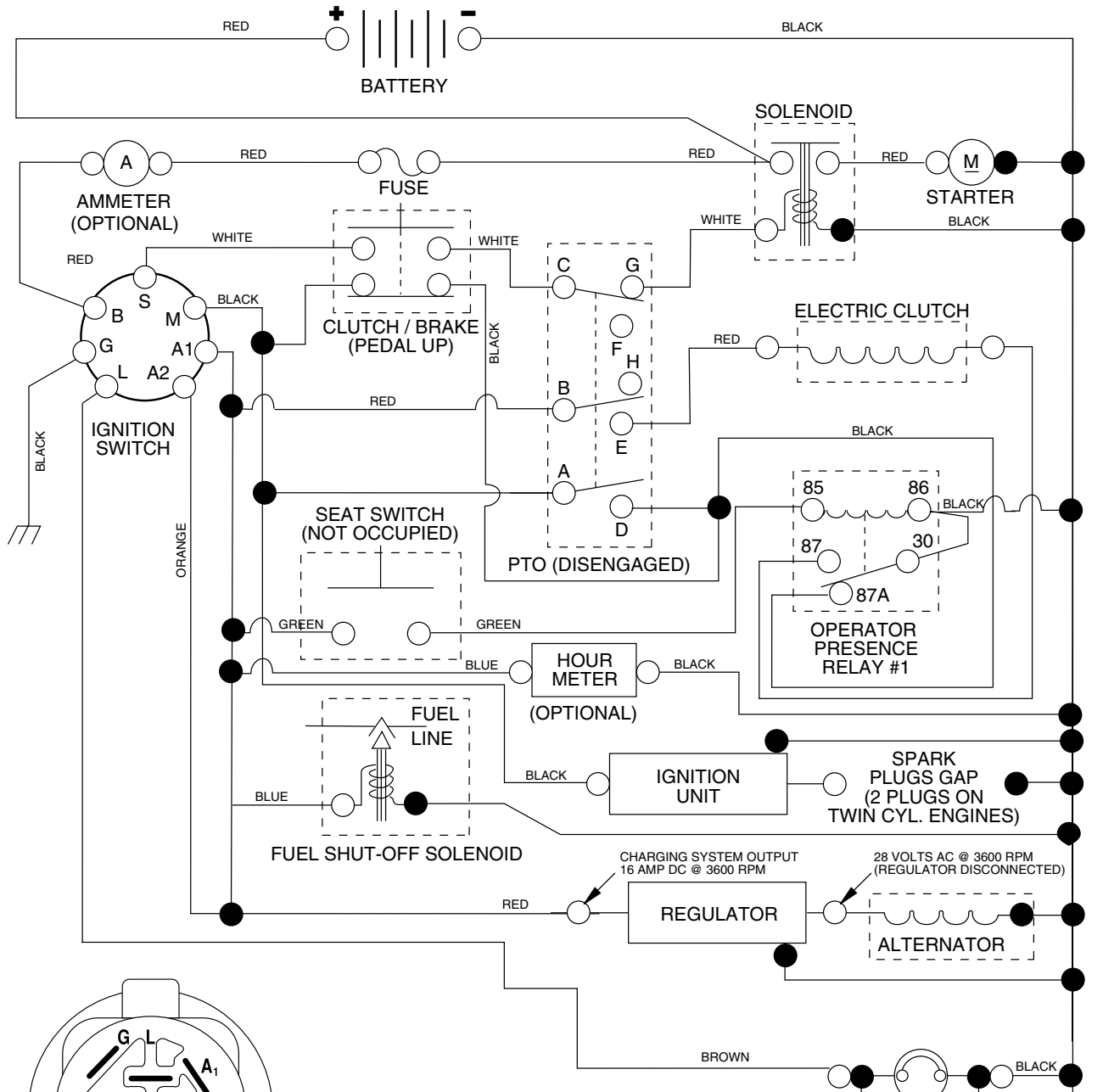

IGNITION SWITCH

POSITION	CIRCUIT	"MAKE"
OFF	M+G+A1	NONE
RUN/LIGHT	B+A1	A2+L
RUN	B+A1	NONE
START	B + S + A1	NONE

WIRING INSULATED CLIPS
NOTE: IF WIRING INSULATED CLIPS WERE REMOVED FOR SERVICING OF UNIT, THEY SHOULD BE REPLACED TO PROPERLY SECURE YOUR WIRING.

PTO SWITCH

POSITION	CIRCUIT
OFF	C + G, B + H
ON	C + F, B + E, A + D

NON-REMOVABLE CONNECTIONS
 REMOVABLE CONNECTIONS

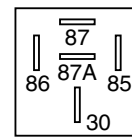

RELAY

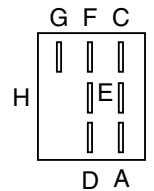

REPAIR PARTS

TRACTOR - MODEL NO. YTH1542XP (HAU15H42E)

ELECTRICAL

KEY NO.	PART NO.	DESCRIPTION
1	532 14 49-27	Battery
2	874 76 04-12	Bolt Hex Hd 1/4-20 Unc x 3/4
8	532 12 48-86	Tray Battery
10	532 14 52-11	Bolt Brt Frt 1/4-20 x 75 Ainc
11	532 15 01-09	Holddown Battery Front Mount
12	532 14 57-69	Nut Push Nylon 1/4" Battery Frt
16	532 17 61-38	Switch Interlock Push-In
21	532 17 56-85	Harness Asm Light W/4152j
22	532 00 41-52	Bulb Light #1156
24	532 14 61-48	Cable Battery 6 Ga 22" red w/16 wire
25	532 12 47-80	Cable Battery 6 Ga 11" red
26	532 17 51-58	Fuse
27	873 51 04-00	Nut Keps Hex 1/4-20 Unc
28	532 14 54-91	Cable Ground 6 Ga 21" black
29	532 16 07-84	Switch Plunger Nc Gray
30	532 17 55-66	Switch Ign
33	532 14 04-01	Key Ign Molded Generic
40	532 17 97-24	Harness Ign.
41	871 11 04-08	Bolt Blk Fin Hex 1/4 - 20 x 1/2
42	532 13 15-63	Cover Terminal Red
43	532 17 88-61	Solenoid
45	532 12 28-22	Ammeter Rectangular 15 Amp
46	532 16 96-35	Meter Hour
50	532 17 46-51	Switch PTO
51	532 14 04-05	Ring Retainer PTO
55	817 49 05-08	Screw Thdrol 5/16-18 x 1-1/2 Tyt
80	532 14 66-85	Harness Clutch Evx
81	532 10 97-48	Relay Asm.
89	532 16 96-39	Bracket Snap-In Hourmeter

NOTE: All component dimensions given in U.S. inches.
1 inch = 25.4 mm.

REPAIR PARTS

TRACTOR - MODEL NO. YTH1542XP (HAU15H42E)

CHASSIS AND ENCLOSURES

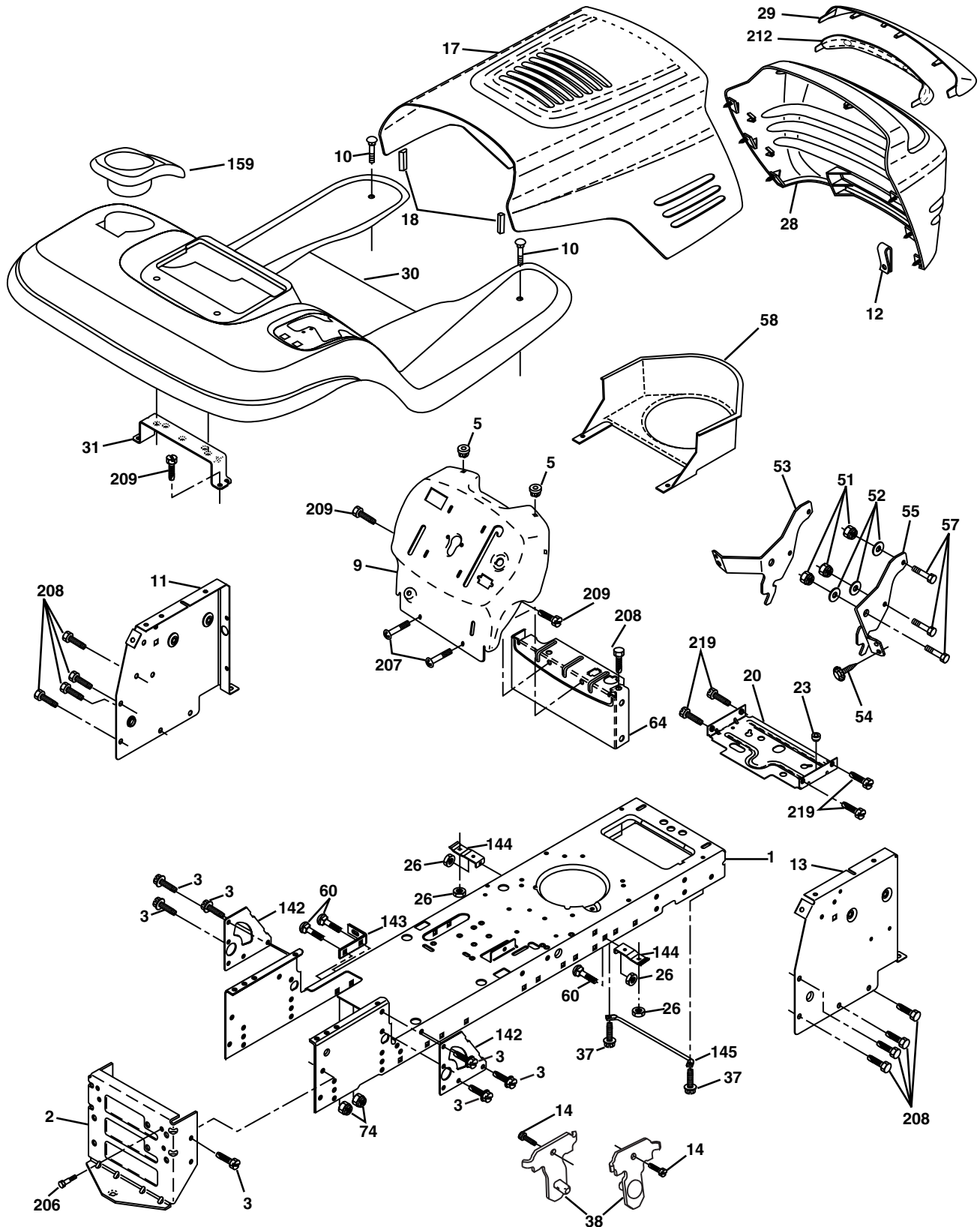

REPAIR PARTS

TRACTOR - MODEL NO. YTH1542XP (HAU15H42E)

CHASSIS AND ENCLOSURES

KEY NO.	PART NO.	DESCRIPTION
1	532 17 46-19	Chassis Stamping
2	532 17 65-54	Drawbar
3	817 06 06-12	Screw 3/8-16x3/4
5	532 15 52-72	Bumper
9	532 17 16-82	Dashboard
10	872 14 06-08	Bolt Rdhd Sqnk 3/8-16 Unc x 1
11	532 17 49-96	Panel Dash Lh
12	532 14 56-60	Clip Tinnerman Grille
13	532 17 21-06	Panel Dash Rh
14	817 49 06-08	Screw Thdrol 3/8-16 x 1/2
17	532 16 22-37	Hood
18	532 18 49-21	Bumper Extrusion
20	532 18 06-79	Plate Mtg Battery/Fuel Tank
23	532 12 40-28	Bushing
26	873 80 06-00	Nut Lock w/Insert 3/8-16 UNC
28	532 17 98-45	Grille Lens Asm
29	532 17 66-45	Lens
30	532 18 10-01	Fender
31	532 13 99-76	Bracket
37	817 49 05-08	Screw Thdrol 5/16-18 x 1/2
38	532 17 57-10	Bracket Asm Pivot Mower Rear
51	873 80 04-00	Nut Lock w/Insert 1/4-20
52	819 09 14-16	Washer 9/32 x 7/8 x 16 Ga.
53	532 14 46-97	Bracket Grille Lh
54	532 16 14-64	Screw Hex Wshd 8-18 x 7/8
55	532 14 46-96	Bracket Grille Rh
57	874 78 04-12	Bolt Fin Hex 1/4-20 Unc x 3/4
58	532 18 44-60	Duct Air
60	872 14 06-06	Bolt RDHD SQNK 3/8-16 x 3/4
64	532 15 47-98	Dash Lower Stlt
74	873 68 06-00	Nut Crownlock 3/8-16
142	532 17 57-02	Plate Reinforcement Stlt
143	532 15 49-66	Bracket Swaybar Chassis
144	532 17 55-82	Bracket Ft Rest
145	532 15 65-24	Rod Pivot Chassis Hood
159	532 16 65-08	Cupholder YTGT Grey
206	532 17 01-65	Bolt Shoulder 5/16-18 TT
207	817 67 05-08	Screw Thdrol 5/16-18 x 1/2 TYTT
208	817 67 06-08	Screw Thdrol 3/8-16 x 1/2 Ty-TT
209	817 00 06-12	Screw Hexwsh Thdr 3/8-16 x 3/4
212	532 15 62-29	Insert Lens Reflect
219	817 00 05-12	Screw 5/16-18 x 3/4

NOTE: All component dimensions given in U. S. inches.
1 inch = 25.4 mm

REPAIR PARTS

TRACTOR - MODEL NO. YTH1542XP (HAU15H42E)

DRIVE

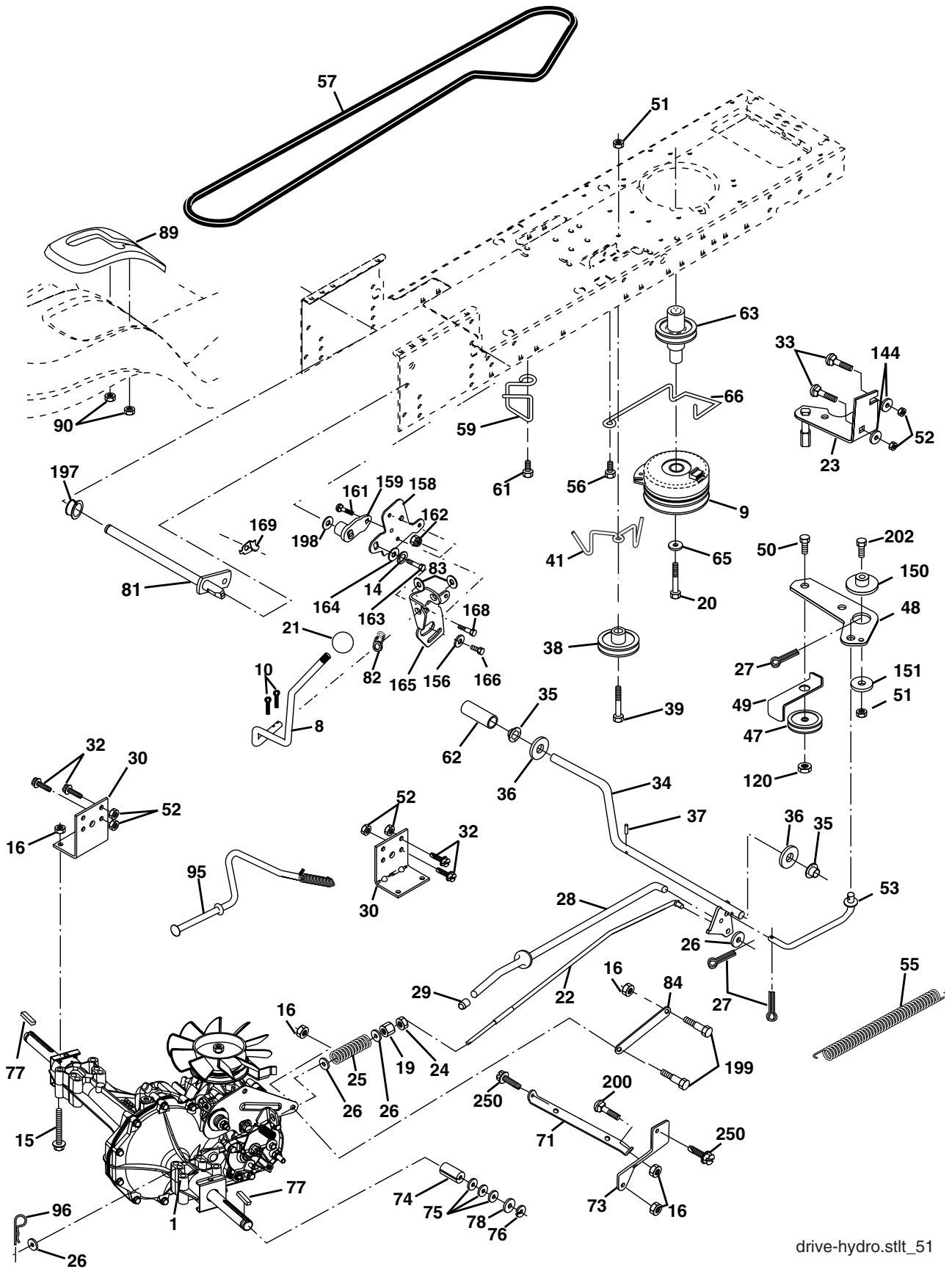

REPAIR PARTS

TRACTOR - MODEL NO. YTH1542XP (HAU15H42E)

DRIVE

KEY NO.	PART NO.	DESCRIPTION	KEY NO.	PART NO.	DESCRIPTION
1	-----	Transaxle, Hydro 314-0510 (Order Parts From Transaxle Manufacturer)	65	810 04 07-00	Washer Lock Hvy HLCL Spr 7/16
8	532 16 58-66	Rod Shift Fender Adjust STLT	66	532 15 47-78	Keeper Belt Engine
9	532 16 08-89	Clutch Electric	71	532 16 91-83	Strap Torque Lh Hydro
10	876 02 04-16	Pin Cotter 1/8 x 1 CAD	73	532 16 91-82	Strap Torque Rh Hydro
14	810 04 04-00	Washer Lock Hvy Helical	74	532 13 70-57	Spacer, Axle
15	874 49 05-44	Bolt Hex 5/16-18 Unc Flghd	75	532 12 17-49	Washer 25/32 x 1-1/4 x 16 Ga.
16	873 80 05-00	Nut Lock Hex W/Ins. 5/16-18 Unc	76	812 00 00-01	E-Ring
19	873 80 06-00	Nut Lock Hex W/Ins 3/8-16 Unc	77	532 12 35-83	Key, Square
20	532 15 02-80	Bolt, Hex 7/16-20 x 4-1/4	78	532 12 17-48	Washer 25/32 x 1-5/8 x 16 Ga
21	532 14 08-45	Knob Deluxe 1/2-13 Unc BLK	81	532 16 55-96	Shaft Asm Cross Tapered
22	532 16 94-98	Rod, Brake Hydro	82	532 16 57-11	Spring Torsion T/A
23	532 17 12-58	Bracket Asm Anti-Rot EVX	83	819 17 12-16	Washer 17/32 x 3/4 x 16 Ga.
24	873 35 06-00	Nut Hex Jam 3/8-16 Unc	84	532 16 95-94	Link Transaxle
25	532 10 68-88	Spring, Brake Rod	89	532 16 65-10	Console, Shift
26	819 13 13-16	Washer	90	532 12 43-46	Nut Self Thd 1/4
27	876 02 04-12	Pin Cotter 1/8 x 3/4 CAD.	95	532 17 02-01	Control Asm. Bypass Hydro
28	532 17 57-65	Rod, Parking Brake	96	532 12 47-88	Retainer Spring 1" Zinc/Cad
29	532 07 16-73	Cap, Parking Brake	120	873 90 06-00	Nut Lock Flg 3/8-16
30	532 16 95-92	Bracket, Transaxle	144	819 11 10-16	Washer 11/32 x 5/8 x 16 Ga.
32	874 76 05-12	Bolt Hex Hd 5/16-18 Unc x 3/4	150	532 17 54-56	Spacer Retainer
33	872 14 05-06	Bolt Carriage 5/16-18 Unc x 3/4	151	819 13 32-10	Washer 13/32 x 2 x 10 Ga.
34	532 17 55-78	Shaft, Foot Pedal	156	532 16 60-02	Washer Srrted 5/16 ID x 1.125
35	532 12 01-83	Bearing, Nylon	158	532 16 55-89	Bracket Shift Mount
36	819 21 16-16	Washer	159	532 18 39-00	Hub Shift
37	532 12 49-63	Pin, Roll	161	872 14 04-06	Bolt Rdhd Sqnk 1/4-20 x 3/4 Gr 5
38	532 17 91-14	Pulley, Composite, Flat	162	873 68 04-00	Nut Crownlock 1/4-20 Unc
39	874 76 06-48	Bolt, Fin, Hex 3/8-16 x 3	163	874 78 04-16	Bolt Hex Fin 1/4-20 Unc x 1 Gr 5
41	532 17 55-56	Keeper, Belt Idler	164	819 09 10-10	Washer 5/8 x .281 x 10 Ga
47	532 12 77-83	Pulley, Idler, V-Groove Plastic	165	532 16 56-23	Bracket Pivot Lever
48	532 15 44-07	Bellcrank Clutch Grnd Drv STL	166	532 16 68-80	Screw 5/16-18 x 5/8
49	532 12 32-05	Retainer, Belt Style Spring	168	532 16 54-92	Bolt Shoulder 5/16-18 x .561
50	872 11 06-12	Bolt Hex Hd 3/8-16 x 1-1/2 Gr. 5	169	532 16 55-80	Plate Fastening STLT/CRD
51	873 68 06-00	Nut	197	532 16 96-13	Nyliner Snap 5/8" ID
52	873 68 05-00	Nut Crown Lock 5/16-18	198	532 16 95-93	Washer Nyl 7/8 ID x .105 Hyd
53	532 10 57-10	Link, Clutch	199	532 16 96-12	Bolt Shoulder 5/16-18 Unc
55	532 10 57-09	Spring, Return, Clutch	200	872 14 05-08	Bolt Rdhd Sqnk 5/16-18 Unc x 1
56	817 06 06-20	Screw 3/8-16 x 1-1/4	202	872 11 06-14	Bolt 3/8-16 Unc x 1-3/4 Gr. 5
57	532 14 02-94	V-Belt, Ground Drive	250	817 06 06-12	Screw 3/8-16 x .75
59	532 16 96-91	Keeper, Center Span			
61	817 12 06-14	Screw 3/8-16 x .875			
62	532 12 48-72	Cover, Pedal			
63	532 17 54-14	Pulley, EGINE			

NOTE: All component dimensions given in U.S. inches
1 inch = 25.4 mm

REPAIR PARTS

TRACTOR - MODEL NO. YTH1542XP (HAU15H42E)

STEERING ASSEMBLY

KEY NO.	PART NO.	DESCRIPTION
1	532 16 66-27	Wheel Steering
2	532 18 47-06	Axle Cast Lt Machined
3	532 16 98-40	Spindle Asm LH
4	532 16 98-39	Spindle Asm RH
5	532 12 49-31	Bearing Race Thrust Harden
6	532 12 17-48	Washer 25/32 x 1-5/8 x 16 Ga
8	812 00 00-29	Ring Klip #t5304-75
10	532 17 51-21	Link Drag
11	810 04 06-00	Washer Lock Hvy Hlcl Spr 3/8
12	873 94 08-00	Nut Hex Jam Toplock 1/2-20 Unf
13	532 13 65-18	Spacer Brg Axle Front
15	532 14 52-12	Nut Hex Flange Lock
17	532 18 06-41	Shaft Asm Strg
29	817 06 06-12	Screw 3/8-16 x 3/4
32	532 17 18-88	Rod Tie
33	819 11 12-16	Washer 11/32 x 3/4 x 16 Ga.
34	810 04 05-00	Washer Lock Hvy Helical 5/16
35	873 54 05-00	Nut Crown Lock 5/16-24 Unf
36	532 15 50-99	Bushing Strg
37	532 15 29-27	Screw
38	532 16 66-26	Insert Cap Strg Wh
39	819 18 24-11	Washer 9/16 x 1-1/2
40	532 12 47-01	Lock nut
41	532 15 99-45	Adaptor Wheel Strg
42	532 16 96-34	Boot Steering Shaft
43	532 12 17-49	Washer 25/32 x 1 1/4 x 16 Ga
44	532 18 06-40	Extension Steering Shaft LR/LT
46	532 12 12-32	Cap Spindle Fr Top Blk
51	873 54 04-00	Nut Crownlock 1/4-28
54	871 13 04-20	Bolt Hex 1/4-28 x 1-1/4 Gr.5
65	532 16 03-67	Spacer Brace Axle
67	872 14 06-18	Bolt Rdhd Sq 3/8-16 x 2-1/4
68	532 16 98-27	Axle, Brace
71	532 17 51-46	Steering Asm
82	532 16 98-35	Bracket Susp Chassis Front
87	532 17 39-66	Washer Flat .781 x 1-1/2 x .14
88	532 17 51-18	Bolt Shoulder 7/16-20
91	532 17 55-53	Clip Steering

NOTE: All component dimensions given in U.S. inches.
1 inch = 25.4 mm.

REPAIR PARTS

TRACTOR - MODEL NO. YTH1542XP (HAU15H42E)

SEAT ASSEMBLY

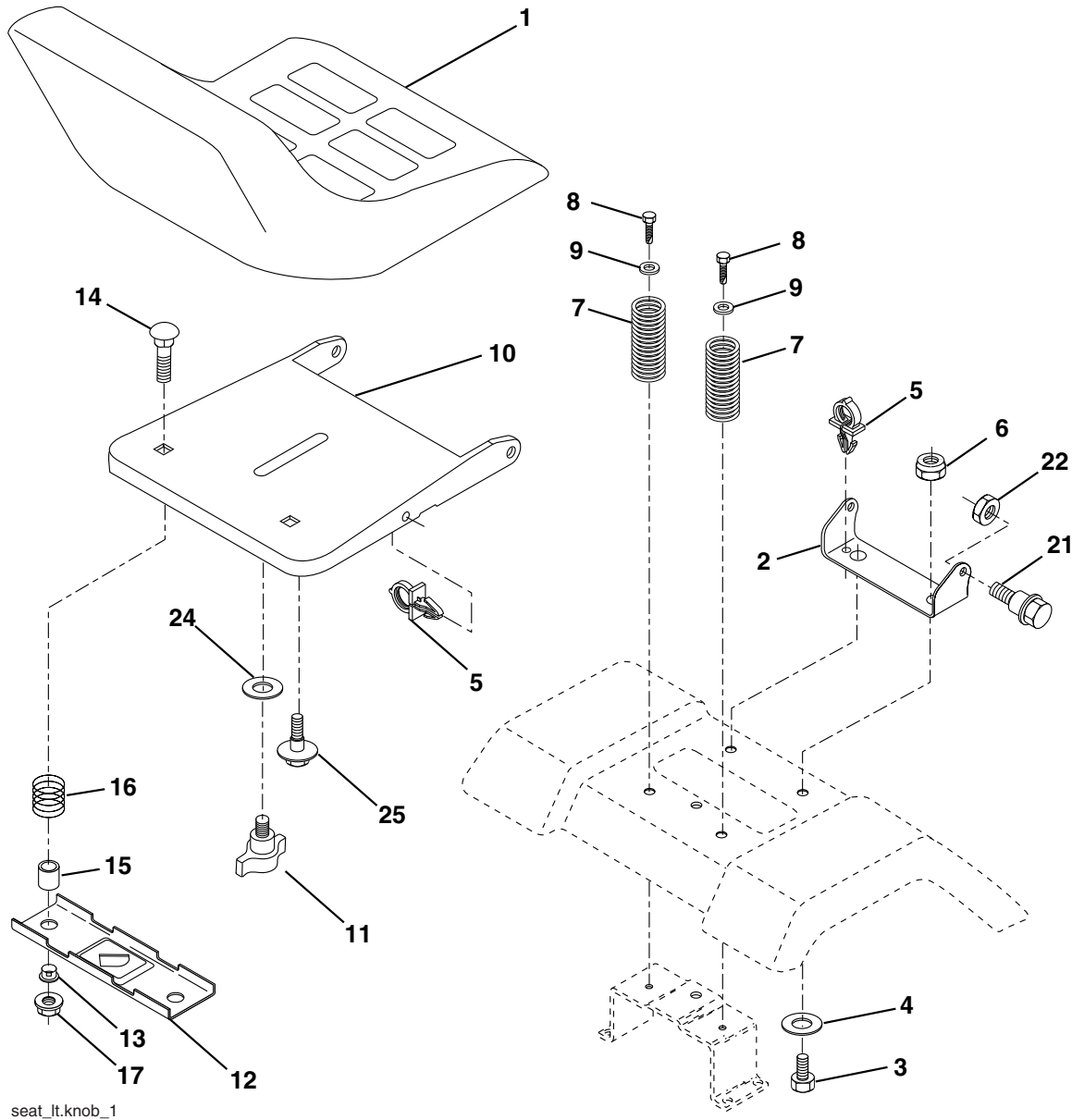

KEY NO.	PART NO.	DESCRIPTION
1	532 14 08-40	Seat
2	532 14 05-51	Bracket Pivot Seat 8 720
3	871 11 06-16	Bolt Fin Hex 3/8-16 x 1
4	819 13 16-10	Washer Flat 13/32 x 1.0 x 10 Ga.
5	532 14 50-06	Clip Push-In
6	873 80 06-00	Nut Hex w/Ins. 3/8-16 Unc
7	532 12 41-81	Spring Seat Cprsn 2 250 Blk Zi
8	817 00 06-16	Screw 3/8-16 x 1
9	819 13 16-14	Washer 13/32 x 1.0 x 14 Ga.
10	532 18 24-93	Pan Seat
11	532 16 63-69	Knob Seat Adj Wingnut
12	532 12 12-46	Bracket Mounting Switch
13	532 12 12-48	Bushing Snap Blk Nyl 50 Id

KEY NO.	PART NO.	DESCRIPTION
14	872 05 04-12	Bolt Rdhd Sqnk 1/4-20 x 1-1/2
15	532 12 12-49	Spacer Split 28 x .88 Zinc
16	532 12 37-40	Spring Cprsn Plate
17	532 12 39-76	Nut Lock 1/4 Lge Flg Gr 5 Zinc
21	532 17 18-52	Bolt Shoulder 5/16-18 Unc
22	873 80 05-00	Nut Hex Lock W/Ins 5/16-18
24	819 17 19-12	Washer 17/32 x 1 -3/16 x 12 Ga.
25	532 12 70-18	Bolt Shoulder 5/16-18 x 62

NOTE: All component dimensions given in U.S. inches.
1 inch = 25.4 mm

REPAIR PARTS

TRACTOR - MODEL NO. YTH1542XP (HAU15H42E)

DECALS

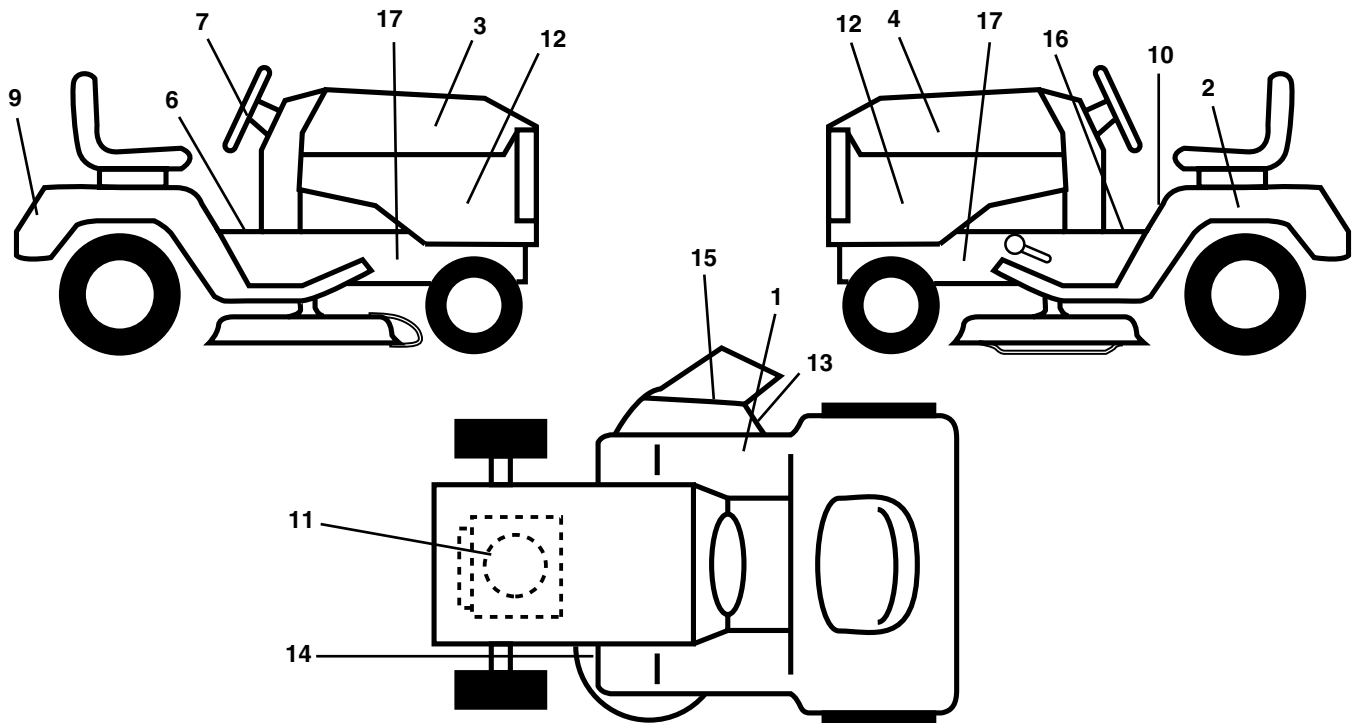

KEY NO.	PART NO.	DESCRIPTION
1	532 16 88-69	Decal Tick Mark
2	532 14 50-05	Decal Battery
3	532 17 77-43	Decal Hood RH
4	532 17 77-44	Decal Hood LH
6	532 14 08-37	Decal Brake Parking
7	532 17 05-64	Decal Wheel Steering
9	532 17 68-22	Decal Fender Husq
10	532 14 54-98	Decal Read Owner's Manual Syms
11	532 18 54-35	Decal Engine
12	532 18 00-91	Decal Hood

KEY NO.	PART NO.	DESCRIPTION
13	532 18 21-66	Decal Cutting Finger
14	532 16 03-96	Decal V-Belt Schematic
15	532 17 91-28	Decal Deck "B" 42"
16	532 15 97-37	Decal Brake/Clutch Symbol
17	532 15 97-36	Decal Chassis Hot Muffler
--	532 16 25-98	Decal Draw Bar Load Limit
--	532 17 12-84	Pad Footrest LH
--	532 17 12-85	Pad Footrest RH
--	532 13 83-11	Decal Handle Lft Height Adjust
--	532 16 69-60	Decal By Pass Hydro
--	532 18 78-96	Manual Owner's (English)

WHEELS & TIRES

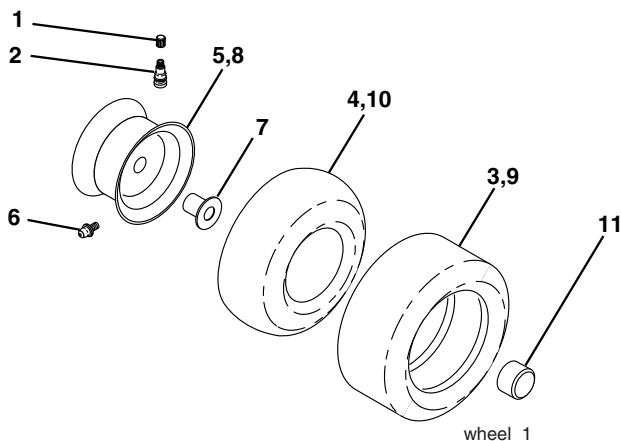

KEY NO.	PART NO.	DESCRIPTION
1	532 05 91-92	Cap Valve Tire
2	532 06 51-39	Stem Valve
3	532 10 62-22	Tire F Ts 15 x 6 0 - 6 Service
4	532 05 99-04	Tube Front (Service Item Only)
5	532 13 83-36	Rim Asm 6"front Silver Service
6	532 12 49-57	Fitting Grease (Front Wheel Only)
7	532 12 49-59	Bearing Flange (Front Wheel Only)
8	532 13 83-37	Rim Asm 8"rear Silver Service
9	532 12 20-82	Tire R Ts 20 x 10-8 C Service
10	532 12 49-26	Tube Rear (Service Item Only)
11	532 17 50-39	Cap Axle Blk 1 50 x 1 00
--	532 14 43-34	Sealant, Tire (10 oz. Tube)

NOTE: All component dimensions given in U.S. inches
1 inch = 25.4 mm

REPAIR PARTS

TRACTOR - MODEL NO. YTH1542XP (HAU15H42E)

ENGINE

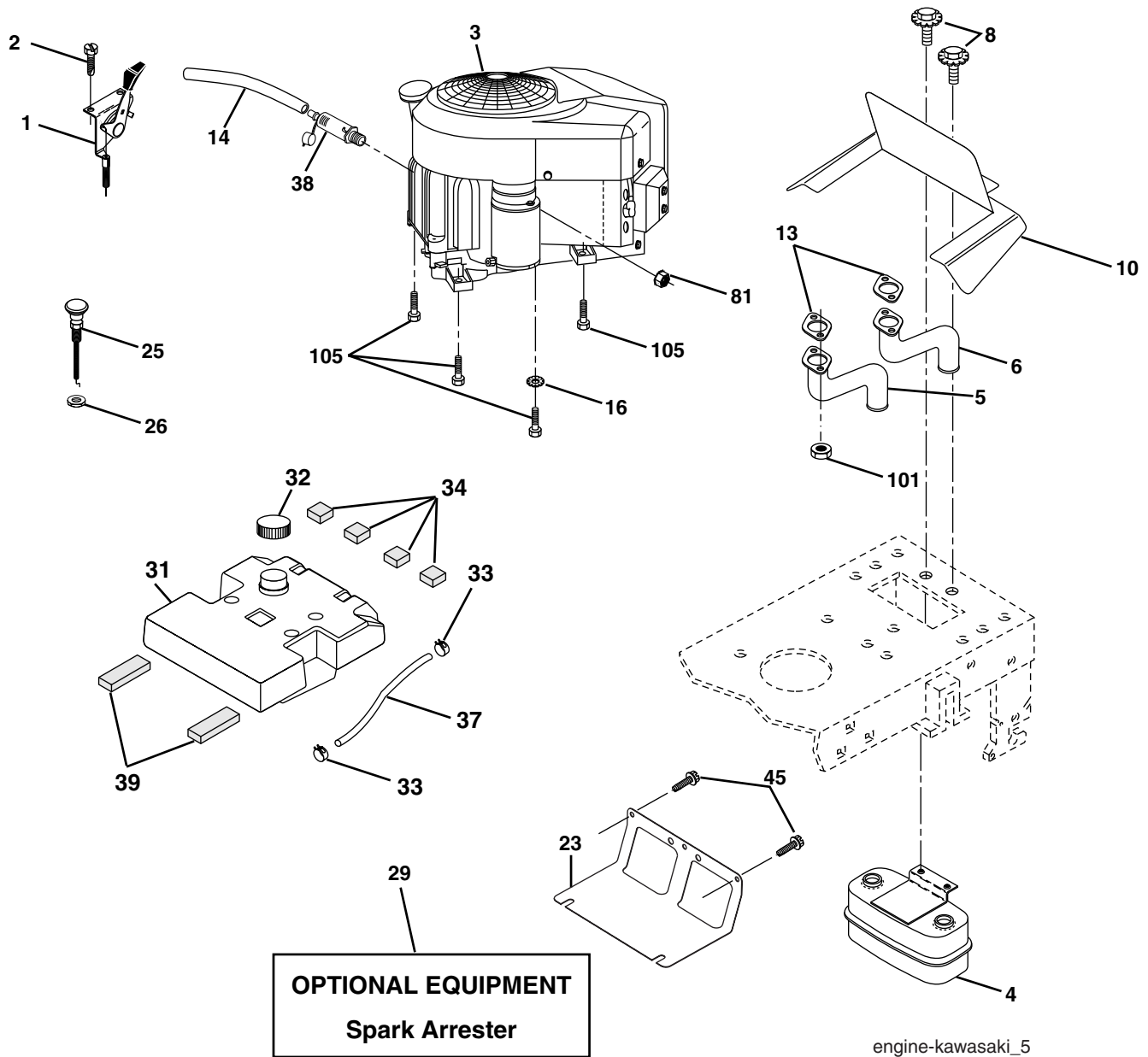

KEY NO.	PART NO.	DESCRIPTION
1	532 17 08-03	Control Throt Flg
2	817 72 04-08	Screw Hex Thd Cut 1/4-20 x 5/8 T
3	-----	Engine KAWA FH430V (Order Parts from Engine Manufacturer)
4	532 14 97-23	Muffler Asm Twin Lo-Tone
5	532 18 14-44	Exhaust Tube Lh
6	532 18 14-42	Exhaust Tube Rh
8	532 17 18-77	Bolt 5/16-18unc x 3/4 W/Sems
10	532 14 66-29	Shield Browning
13	-----	Gasket Muffler (Order from Engine Manufacturer)
14	532 14 84-56	Tube Drain Oil Easy
16	811 05 06-00	Washer Lock Ext Tooth 3/8
23	532 16 98-37	Shield Browning
25	532 13 27-82	Choke Control
26	873 92 06-00	Nut, Keps 3/8-24 Unf

KEY NO.	PART NO.	DESCRIPTION
29	532 13 71-80	Kit Spark Arrestor (Flat Scrn)
31	532 15 71-03	Tank Fuel 3 50 Rear
32	532 14 05-27	Cap Asm Fuel
33	532 12 34-87	Clamp Hose Blk
34	532 10 60-82	Pad, Spacer
37	532 14 21-58	Line Fuel
38	-----	Plug Drain Oil Easy (Order Parts from Engine Manufacturer)
39	532 10 92-27	Pad, Idler
45	817 00 06-12	Screw Hexwsh Thdr 3/8-16 x 3/4
81	873 51 04-00	Nut Keps Hex 1/4-20
101	532 18 43-62	Nut Flange M8-1.25
105	817 12 06-16	Screw 3/8-16 x 1

NOTE: All component dimensions given in U.S. inches
1 inch = 25.4 mm

REPAIR PARTS

TRACTOR - MODEL NO. YTH1542XP (HAU15H42E)

MOWER LIFT

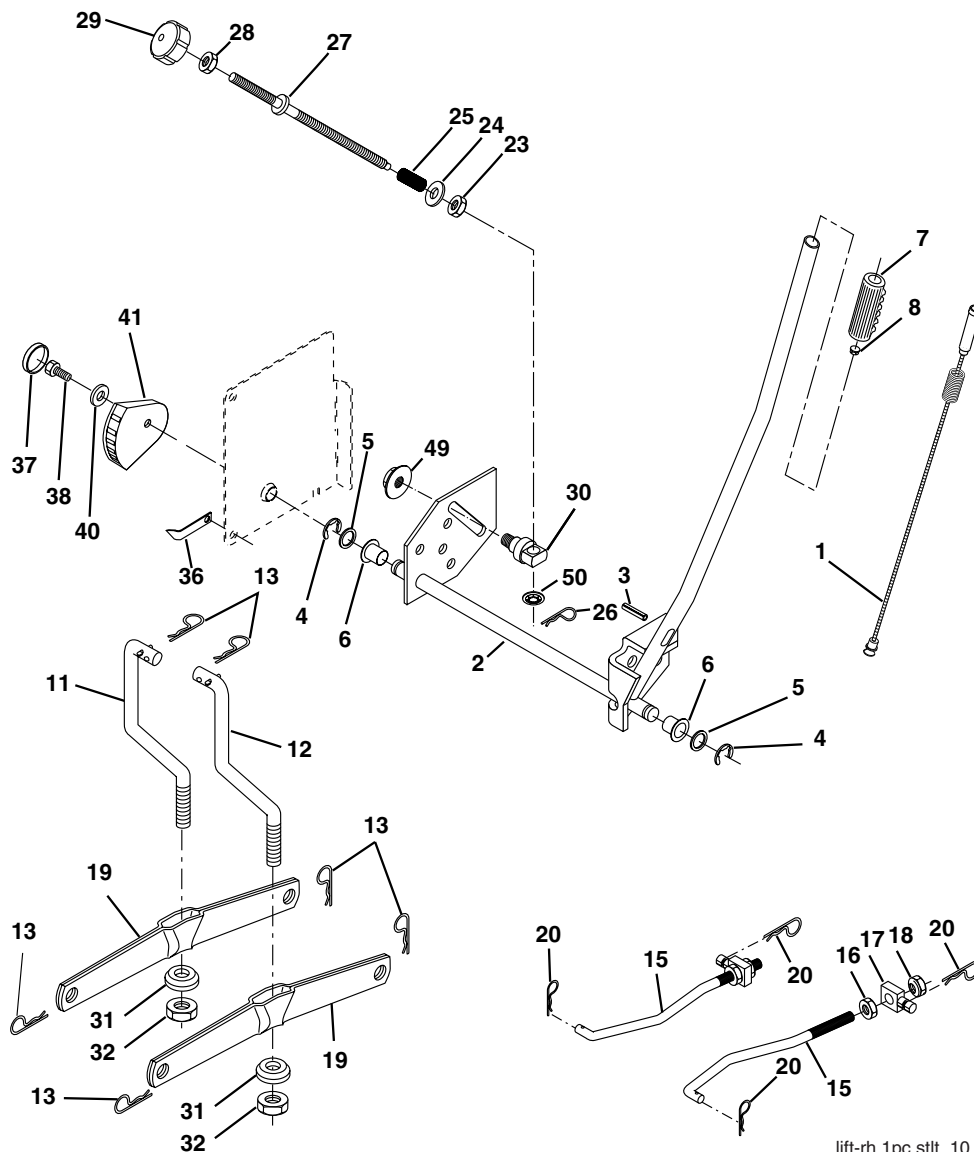

lift-rh.1pc.stit_10

KEY NO.	PART NO.	DESCRIPTION
1	532 15 94-60	Wire Asm Inner/Spring W/ Plunger LT
2	532 15 94-71	Shaft Asm Lift RH w/Inf
3	532 10 57-67	Pin Groove 1 500 Zinc
4	812 00 00-02	E Ring #5133-62
5	819 21 16-21	Washer 21/32 x 1 x 21 Ga
6	532 12 01-83	Bearing Nylon Blk 629 Id
7	532 12 56-31	Grip Handle Fluted Blk
8	532 12 45-26	Button Plunger Black
11	532 13 98-65	Link Lift LH
12	532 13 98-66	Link Lift RH
13	532 12 46-70	Retainer Spring
15	532 17 32-88	Link Front
16	873 35 08-00	Nut Jam Hex 1/2-13 Unc
17	532 17 56-89	Trunnion
18	873 80 08-00	Nut Lock w/Wsh 1/2-13 Unc
19	532 13 98-68	Arm Suspension Rear
20	532 16 35-52	Retainer Spring
23	532 11 08-07	Nut Special

KEY NO.	PART NO.	DESCRIPTION
24	819 13 10-16	Washer 13/32 x 5/8 x 16 Ga
25	532 12 48-74	Spring 2-1/8"
26	532 16 94-84	Retainer Clip
27	532 12 69-71	Rod Adj Lift Zinc 7.49 Wrk Lg
28	873 35 06-00	Nut Hex Jam 3/8-16 Unc
29	532 13 80-57	Knob Inf 3/8-16 Unc Blk W/sym
30	532 15 02-33	Trunnion Infin Height
31	532 16 98-65	Bearing PVT Lift
32	873 54 06-00	Nut Crownlock 3/8-24
36	532 15 50-97	Indicator Height STLT
37	532 12 39-35	Plug Hole Blk 1.485/1.515 Dia.
38	817 06 05-16	Screw 5/16-18 x 1
40	819 11 24-10	Washer 11/32 x 1-1/2 10 Ga.
41	532 15 50-98	Scale Ind. Height Blk.
49	532 14 52-12	Nut Hex Flange Lock
50	532 11 04-52	Nut, Push Phos & Oil

NOTE: All component dimensions given in U.S. inches
1 inch = 25.4 mm

REPAIR PARTS

TRACTOR - MODEL NO. YTH1542XP (HAU15H42E)

MOWER DECK

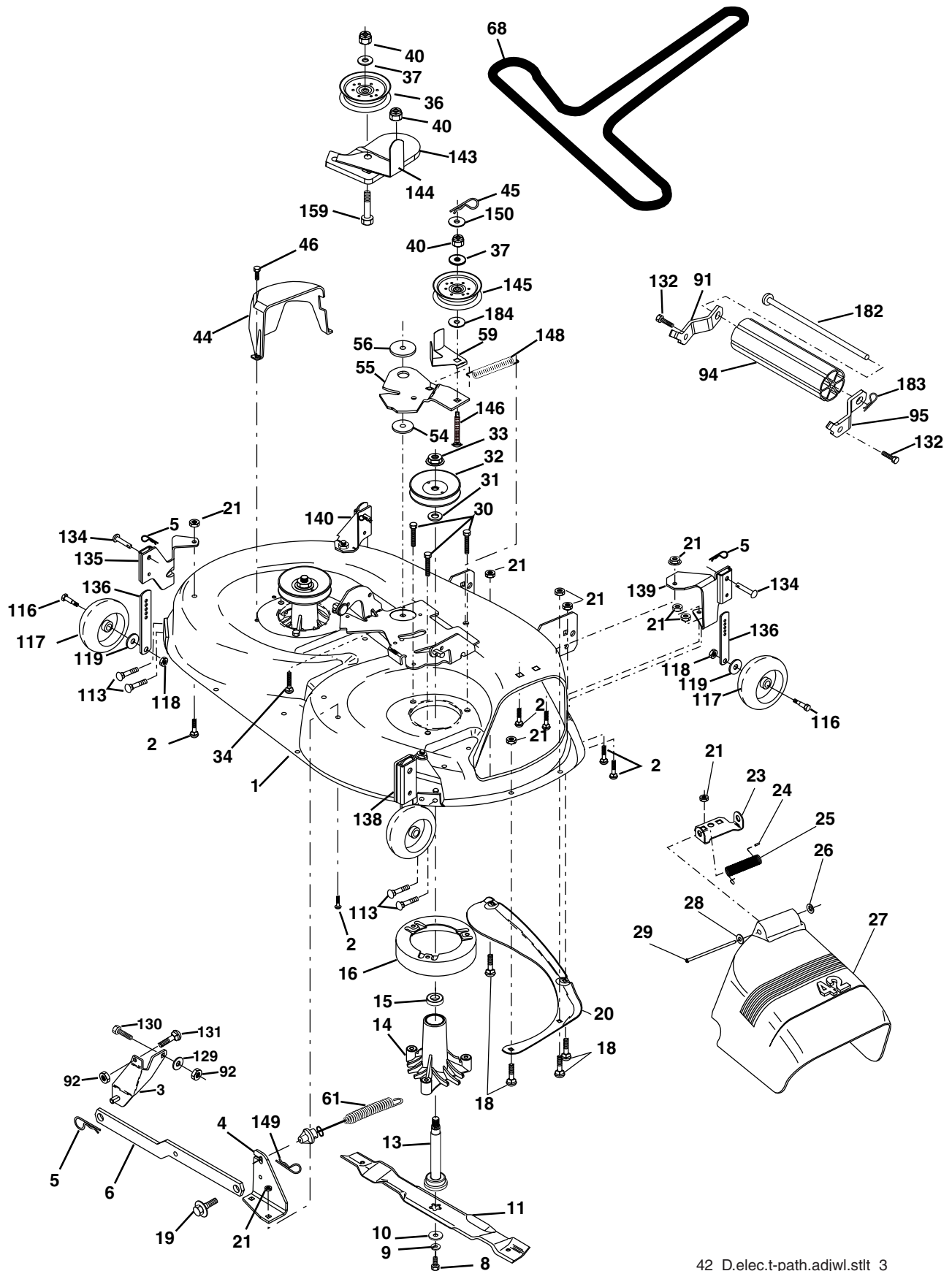

REPAIR PARTS

TRACTOR - MODEL NO. YTH1542XP (HAU15H42E)

MOWER DECK

KEY NO.	PART NO.	DESCRIPTION	KEY NO.	PART NO.	DESCRIPTION
1	532 18 54-38	Mower Deck Assembly, 42"	61	532 17 48-82	Spring Ext Elect Clutch 42" Dck
2	872 14 05-06	Bolt	68	532 17 48-83	V-Belt
3	532 13 80-17	Bracket Assembly,Sway Bar, Front	91	532 18 05-32	Bracket Asm Noseroller Lh
4	532 16 54-60	Bracket Sway Bar 42" Deck	92	873 80 06-00	Nut Lock Hex 3/8-16
5	532 12 46-70	Retainer Spring	94	532 13 22-64	Roller Nose 38"-50"
6	532 17 80-24	Bar Sway Deck	95	532 18 05-33	Bracket Asm Noseroller Rh
8	532 85 08-57	Bolt, Hex 3/8-24 x 1.25 Gr. 8	113	817 06 05-12	Screw 5/16-18 x 3/4 Tap R
9	810 03 06-00	Washer, Lock	116	532 18 42-19	Bolt, Shoulder
10	532 14 02-96	Washer, Hardened	117	532 13 99-57	Wheel, Gauge
11	532 13 84-91	Blade Mower 42" High Perf.	118	873 93 06-00	Nut, Centerlock 3/8-16
13	532 13 76-45	Shaft Assembly, Mandrel, Vented	119	819 12 14-14	Washer 3/8 x 7/8 x 14 Gauge
14	532 12 87-74	Housing, Mandrel, Vented	129	819 13 13-12	Washer 13/32 x 13/16 x Ga.
15	532 11 04-85	Bearing, Ball, Mandrel	130	874 78 06-16	Bolt Fin Hex 3/8-16 Unc x 1 Gr.5
16	532 17 44-93	Stripper	131	872 14 06-08	Bolt Rdhd Sqnk 3/8-16 Unc x 1
18	872 14 05-05	Bolt, Carriage 5/16-18 x 5/8	132	817 00 06-12	Screw 3/8-16 x .75
19	532 13 28-27	Bolt, Shoulder	134	532 15 69-41	Pin Head Rivet
20	532 15 97-70	Baffle, Vortex	135	532 17 80-74	Bracket Asm Whl GA R LH
21	873 68 05-00	Nut Crownlock 5/16-18 Unc	136	532 15 59-86	Bar Adjusting GA WHL
23	532 17 75-63	Bracket, Deflector	138	532 17 80-75	Bracket Asm Whl GA R RH
24	532 10 53-04	Cap, Sleeve	139	532 17 80-77	Bracket Asm Whl GA F RH
25	532 12 37-13	Spring, Torsion, Deflector	140	532 17 80-76	Bracket Asm Whl GA F LH
26	532 11 04-52	Nut, Push	143	532 15 71-09	Bracket Arm Idler 42"
27	532 17 18-59	Shield, Deflector	144	532 17 34-41	Keeper Belt 42" Clutch Cable
28	819 11 10-16	Washer 11/32 x 5/8 x 16 Ga.	145	532 17 34-37	Pulley Idler Flat
29	532 13 14-91	Rod, Hinge	146	532 17 34-43	Bolt Carriage Idler
30	532 17 39-84	Screw Thdrol Hex	148	532 16 90-22	Spring Return Idler
31	532 12 99-63	Washer, Spacer	149	532 16 58-98	Retainer Spring Yellow Zinc
32	532 17 34-36	Pulley, Mandrel	150	819 09 12-16	Washer 9/32 x 3/4 x 16 Ga.
33	532 17 83-42	Nut, Toplock, Flanged	159	872 14 06-14	Bolt Rdhd Sqn 3/8-16 Unc x 1-3/4
34	872 11 06-14	Bolt			
36	532 17 34-38	Pulley, Idler, Flat	182	532 17 91-26	Rod Roller Nose
37	819 13 13-16	Washer 13/32 x 13/16 x 16 Ga.	183	532 16 35-52	Retainer Spring
40	873 68 06-00	Nut Crownlock 3/8-16 Unc	184	819 13 14-10	Washer 13/32 x 7/8 x 10 Ga.
44	532 14 00-88	Guard, Mandrel, L.H.	--	532 13 07-94	Mandrel Assembly (Includes Housing, Shaft and Shaft Hardware Only - Pulley Not Included)
45	532 12 47-88	Retainer			
46	532 13 77-29	Screw, Thd. Roll 1/4-20 x 5/8	--	532 17 60-50	Replacement Mower, Complete
54	532 17 85-15	Washer, Hardened			
55	532 15 50-46	Arm, Idler			
56	532 12 20-52	Spacer, Retainer			
59	532 17 34-42	Guard, TUV Idler			

NOTE: All component dimensions given in U.S. inches
1 inch = 25.4 mm