

YTH1542 XP

Spare parts

Ersatzteile

Pièces détachées

Reserve onderdelen

Repuestos

Reservdelar

TRACTOR - MODEL NO. YTH1542XP (HAU15H42F), PRODUCT NO. 954 17 02-25

SCHEMATIC

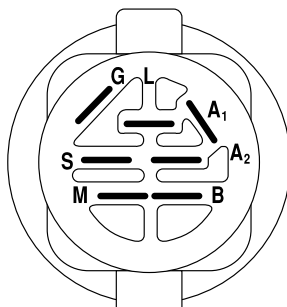
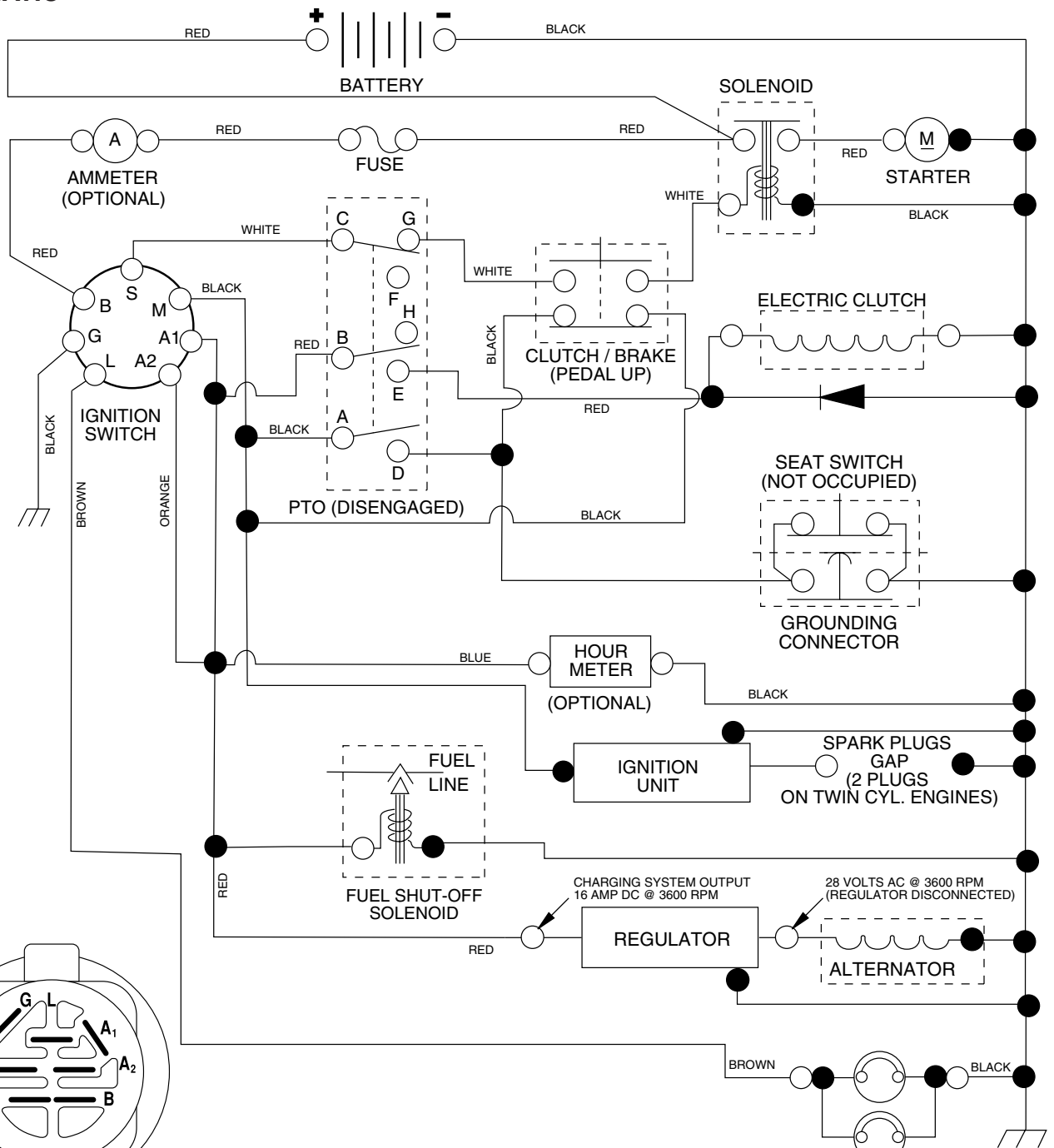

IGNITION SWITCH

POSITION	CIRCUIT	"MAKE"
OFF	M + G + A1	NONE
ON + LIGHTS	B + A1	L + A2
ON	B + A1	NONE
START	B + S + A1	NONE

WIRING INSULATED CLIPS
NOTE: IF WIRING INSULATED CLIPS WERE REMOVED FOR SERVICING OF UNIT, THEY SHOULD BE REPLACED TO PROPERLY SECURE YOUR WIRING.

PTO SWITCH

POSITION	CIRCUIT
OFF	C + G, B + H
ON	C + F, B + E, A + D

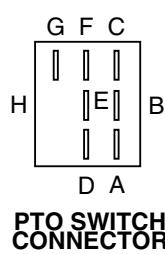

REPAIR PARTS

TRACTOR - MODEL NO. YTH1542XP (HAU15H42F), PRODUCT NO. 954 17 02-25
ELECTRICAL

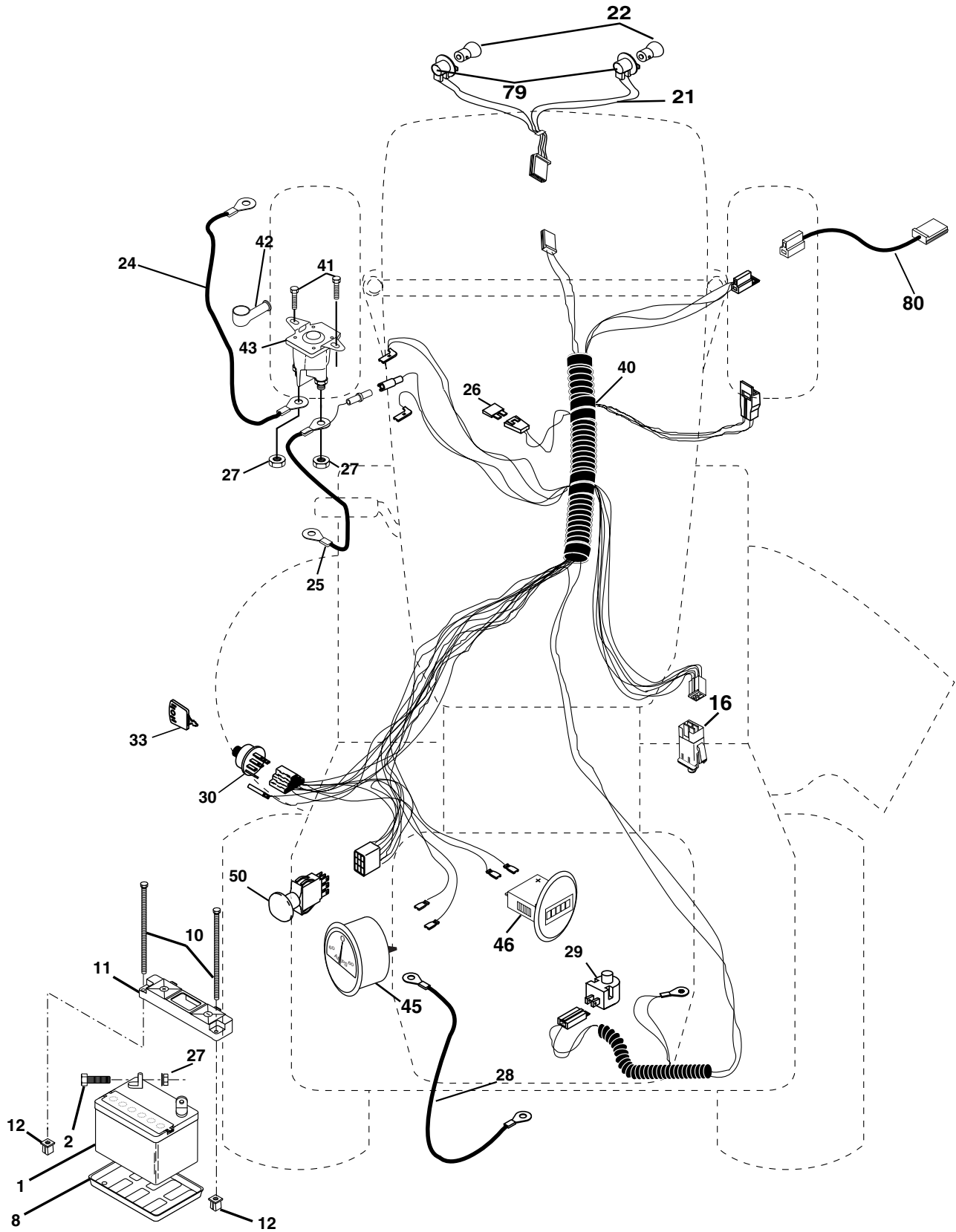

REPAIR PARTS

TRACTOR - MODEL NO. YTH1542XP (HAU15H42F), PRODUCT NO. 954 17 02-25
ELECTRICAL

KEY NO.	PART NO.	DESCRIPTION
1	532 14 49-27	Battery
2	874 76 04-12	Bolt Hex Hd 1/4-20 unc x 3/4
8	532 12 48-86	Tray Battery
10	532 14 52-11	Bolt Brt Frt 1/4-20 x 75 A uuinc
11	532 15 01-09	Holddown Battery Front Mount
12	532 14 57-69	Nut Push Nylon 1/4" Battery Frt
16	532 17 61-38	Switch Interlock Push-In
21	532 17 56-88	Harness Asm Light W/4152j
22	532 00 41-52	Bulb Light #1156
24	532 14 61-48	Cable Battery 6 Ga. 22" red w/16 wire
25	532 00 88-60	Cable Battery
26	532 17 51-58	Fuse
27	873 51 04-00	Nut Keps Hex 1/4-20 unc
28	532 14 54-91	Cable Ground 6 Ga 21" black
29	532 12 13-05	Switch Plunger Nc Gray
30	532 17 55-66	Switch Ign
33	532 14 04-01	Key Ign Molded Generic
40	532 18 80-30	Harness Ign.
41	817 72 04-08	Screw 1/4-20 x 1/2
42	532 13 15-63	Cover Terminal Red
43	532 17 88-61	Solenoid
45	532 17 75-00	Ammeter
46	532 17 75-01	Meter Hour
50	532 17 46-51	Switch PTO
79	532 17 52-42	Socket Asm. Bulb Twistlock
80	532 14 66-85	Harness Clutch EVX

NOTE: All component dimensions given in U.S. inches.
1 inch = 25.4 mm.

REPAIR PARTS

TRACTOR - MODEL NO. YTH1542XP (HAU15H42F), PRODUCT NO. 954 17 02-25 CHASSIS AND ENCLOSURES

KEY NO.	PART NO.	DESCRIPTION
1	532 17 46-19	Chassis Stamping
2	532 17 65-54	Drawbar
9	532 18 56-04	Dash
10	872 14 06-08	Bolt Rdhd Sqnk 3/8-16 unc x 1
11	532 16 72-03	Panel Dash Lh
13	532 17 82-98	Panel Dash Rh
14	817 49 06-08	Screw Thdrol 3/8-16 x 1/2
17	532 19 00-55	Hood
20	532 16 20-26	Plate Mtg Battery/Fuel Tank
26	873 80 06-00	Nut Lock w/Insert 3/8-16 unc
28	532 18 28-73	Grille
29	532 18 82-12	Light Box Asm (w/Lens)
30	532 18 54-32	Fender
31	532 13 99-76	Bracket
37	817 49 05-08	Screw Thdrol 5/16-18 x 1/2
38	532 17 57-10	Bracket Asm Pivot Mower Rear
54	532 16 14-64	Screw Hex Wshd 8-18 x 7/8
58	532 18 98-75	Duct Air
59	532 18 74-95	Bushing Snap
60	872 14 06-06	Bolt RDHD SQNK 3/8-16 x 3/4
64	532 17 49-97	Dash Lower Stlt
74	873 68 06-00	Nut Crownlock 3/8-16
90	532 12 43-46	Nut Self-thd Wsh-Hd 1/4
142	532 17 57-02	Plate Reinforcement
143	532 18 66-89	Bracket Swaybar Chassis
144	532 17 55-82	Bracket Ft Rest
145	532 15 65-24	Rod Pivot Chassis Hood
154	532 16 18-97	Bracket Dash RH
155	532 16 19-00	Bracket Dash LH
158	532 16 20-37	Parking Brake Brkt
159	532 18 54-34	Cupholder
161	532 16 46-55	Extrusion Bumper
166	532 17 18-75	HWHDH:-Lo. #13-16 x 3/4
206	532 17 01-65	Bolt Shoulder 5/16-18
209	817 00 06-12	Screw Hexwsh Thdr 3/8-16 c-x 3/4
213	532 17 75-87	Skirt Grille LH
214	532 17 75-86	Skirt Grille RH
217	532 18 54-36	Console Fuel Window

NOTE: All component dimensions given in U. S. inches
1 inch = 25.4 mm

REPAIR PARTS

TRACTOR - MODEL NO. YTH1542XP (HAU15H42F), PRODUCT NO. 954 17 02-25 DRIVE

KEY NO.	PART NO.	DESCRIPTION	KEY NO.	PART NO.	DESCRIPTION
1	-----	Transaxle (Order parts from trans-axle manufacturer) Hydro gear Model 336-0510	78	532 12 17-48	Washer 25/32 x 1-5/8 x 16 Ga.
6	817 06 05-12	Screw 5/16-18	89	532 18 14-94	Console, Shift
9	532 16 08-89	Clutch	90	532 12 43-46	Nut Self-Thd Wsh-hd 1/4 Zinc
15	874 49 05-44	Bolt Hex Flghd 5/16-18 Gr. 5	95	532 18 08-25	Rod Bypass
16	873 80 05-00	Nut Lock Hex W/Ins. 5/16-18 unc	96	532 12 47-88	Retainer Spring
19	873 80 06-00	Nut Lock Hex W/Wsh 3/8-16 unc	120	873 90 06-00	Nut Lock Flg 3/8-16 unc
20	532 15 02-80	Bolt Hex 7/16-20 x 4-1/4 Gr. 5	144	819 11 10-16	Washer 11/32 x 5/8 x 16 Ga.
21	532 18 14-54	Knob Custom Control Cruise	150	532 17 54-56	Spacer Retainer
22	532 17 58-96	Rod, Brake	151	819 13 32-10	Washer 13/32 x 2 x 10 Ga.
23	532 17 12-58	Bracket Anti-Rotation EVX	202	872 11 06-14	Bolt Carr Sh 3/8-16 x 1-3/4 Gr. 5
24	873 35 06-00	Nut, Hex Jam 3/8-16 unc	214	532 17 47-35	Link Transaxle
25	532 10 68-88	Spring, Brake Rod	217	532 17 94-33	Pedal Reverse
26	819 13 13-16	Washer	218	532 17 47-13	Arm Control Pedal Reverse
27	876 02 04-12	Pin Cotter 1/8 x 3/4 CAD.	219	532 17 48-39	Bracket Frest Pdl Ctrl. Hyd
28	532 17 57-65	Rod, Parking Brake	220	532 17 47-11	Bracket Mtg. Pedal Control
29	532 07 16-73	Cap, Brake, Park	221	872 14 06-06	Bolt Rdhd Sqnk 3/8-16 unc x 3/4
30	532 16 95-92	Bracket, Transaxle	222	873 68 07-00	Nut Crownlock 7/16-14 unc
32	874 76 05-12	Bolt Hex Hd 5/16-18 unc x 3/4	223	532 17 48-40	Washer Nylon 11/16 ID x .060
33	872 14 05-06	Bolt Rdhd Sqnk 5/16-18 unc x 3/4	224	532 17 47-36	Pedal Forward
34	532 17 55-78	Shaft, Foot Pedal	225	532 17 47-12	Arm Control Pedal Forward
35	532 12 01-83	Bearing, Nylon	226	532 17 49-02	Bolt Pivot Spacer
36	819 21 16-16	Washer	227	532 17 47-10	Cam Reverse Pedal LT
37	532 12 49-63	Pin, Roll	228	532 17 90-32	Bolt Shoulder 5/16-18
38	532 17 91-14	Pulley, Composite	229	532 17 64-51	Washer Serrated 5/16 x .75
39	872 11 06-22	Bolt Rdhd 3/8-16 unc x 2-3/4 Gr. 5	231	532 17 45-73	Strap Torque
41	532 17 55-56	Keeper, Belt Idler Flat	232	532 17 55-70	Actuator Cruise Disengage
47	532 12 77-83	Pulley, Idler, V-Groove	233	532 17 48-56	Pawl Control Cruise
48	532 15 44-07	Bellcrank Clutch Grnd Drw Stl	234	532 17 48-58	Lever Control Cruise
49	532 12 32-05	Retainer, Belt	235	532 17 48-57	Sector Control Cruise
50	872 11 06-12	Bolt Carr. SH 3/8-16 x 1-1/2 Gr. 5	236	532 12 89-03	Bolt Shoulder 3/8-16 unc 1/44
51	873 68 06-00	Nut Crownlock 3/8-16 unc	237	532 17 01-65	Bolt Shoulder 5/16-18
52	873 68 05-00	Nut, Crownlock 5/16-18 unc	238	532 17 58-07	Arm Mtg. Cruise Sector
53	532 10 57-10	Link, Clutch	239	817 49 05-08	Screw Thdrol 5/16 x 1/2
55	532 10 57-09	Spring, Return, Clutch	240	532 17 56-10	Spring Return Cruise Control
56	817 06 06-20	Screw 3/8-16 x 1-1/4	241	873 93 04-00	Nut Centerlock 1/4-20 unc
57	532 14 02-94	V-Belt, Ground Drive	242	874 78 04-12	Bolt Fin Hex 1/4-20 unc x .75
59	532 16 96-91	Keeper, Center Span	244	817 49 05-10	Screw 5/16-18 x 5/8
61	817 12 06-14	Screw 3/8-16 x .875	251	817 06 05-16	Screw 5/16-18 x 1
62	532 12 48-72	Cover, Pedal	253	532 17 94-22	Washer .312 x .615 x 16 Ga.
63	532 17 54-14	Pulley, Engine	254	532 17 80 62	Clip Retainer
65	810 04 07-00	Washer	263	817 00 06-12	Screw 3/8-16 x 3/4
66	532 15 47-78	Keeper Belt Engine	272	817 67 05-08	Screw Thdrol 5/16-18 x 1/2
74	532 13 70-57	Spacer, Axle	273	532 17 96-10	Pad Pedal Reverse
75	532 12 17-49	Washer 25/32 x 1-1/4 x 16 Ga.	274	532 17 56-46	Cover Pedal Forward
76	812 00 00-01	E-Ring			
77	532 12 35-83	Key, Square			

NOTE:All component dimensions give in U.S. inches.
1 inch = 25.4 mm.

REPAIR PARTS

TRACTOR - MODEL NO. YTH1542XP (HAU15H42F), PRODUCT NO. 954 17 02-25
STEERING ASSEMBLY

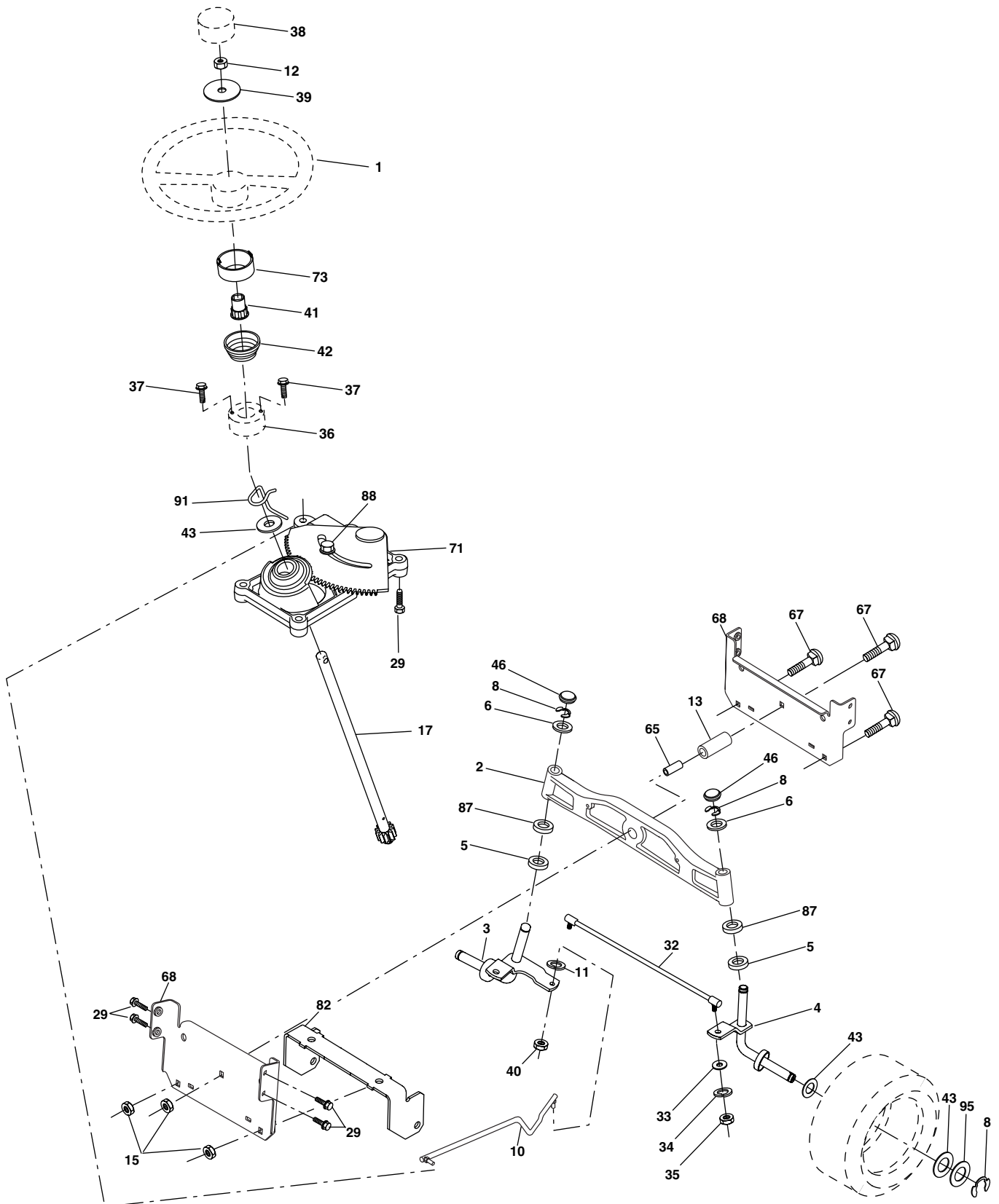

steering_stealth_prem_3

REPAIR PARTS

TRACTOR - MODEL NO. YTH1542XP (HAU15H42F), PRODUCT NO. 954 17 02-25 STEERING ASSEMBLY

KEY NO.	PART NO.	DESCRIPTION
1	532 16 66-27	Wheel Steering
2	532 18 47-06	Axle Cast Lt Machined
3	532 16 98-40	Spindle Asm LH
4	532 16 98-39	Spindle Asm RH
5	532 12 49-31	Bearing Race Thrust Harden
6	532 12 17-48	Washer 25/32 x 1-5/8 x 16 Ga.
8	812 00 00-29	Ring Klip #t5304-75
10	532 17 51-21	Link Drag
11	810 04 06-00	Washer Lock Hvy Hlcl Spr 3/8
12	873 94 08-00	Nut Hex Jam Toplock 1/2-20 unf
13	532 13 65-18	Spacer Brg Axle Front
15	532 14 52-12	Nut Hex Flange Lock
17	532 17 78-83	Shaft Asm Strg
29	817 00 06-12	Screw 3/8-16 x 3/4
32	532 17 18-88	Rod Tie
33	819 11 12-16	Washer 11/32 x 3/4 x 16 Ga.
34	810 04 05-00	Washer Lock Hvy Helical 5/16
35	873 54 05-00	Nut Crown Lock 5/16-24 unf
36	532 15 51-05	Bushing Strg
37	532 15 29-27	Screw
38	532 16 66-26	Insert Cap Strg Wh
39	819 18 24-11	Washer 9/16 x 1-1/2
40	873 54 06-00	Lock nut
41	532 15 99-45	Adaptor Wheel Strg
42	532 19 01-12	Boot Steering
43	532 12 17-49	Washer 25/32 x 1 1/4 x 16 Ga.
46	532 12 12-32	Cap Spindle Fr Top Blk
65	532 16 03-67	Spacer Brace Axle
67	872 11 06-18	Bolt Rdhd Sq 3/8-16 x 2-1/4
68	532 16 98-27	Axle, Brace
71	532 17 51-46	Steering Asm
73	532 17 75-93	Extension Steering
82	532 16 98-35	Bracket Susp Chassis Front
87	532 17 39-66	Washer Flat .781 x 1-1/2 x .14
88	532 17 51-18	Bolt Shoulder 7/16-20
91	532 17 55-53	Clip Steering
95	532 18 89-67	Washer Hardened

NOTE: All component dimensions given in U.S. inches.
1 inch = 25.4 mm.

REPAIR PARTS

TRACTOR - MODEL NO. YTH1542XP (HAU15H42F), PRODUCT NO. 954 17 02-25
ENGINE

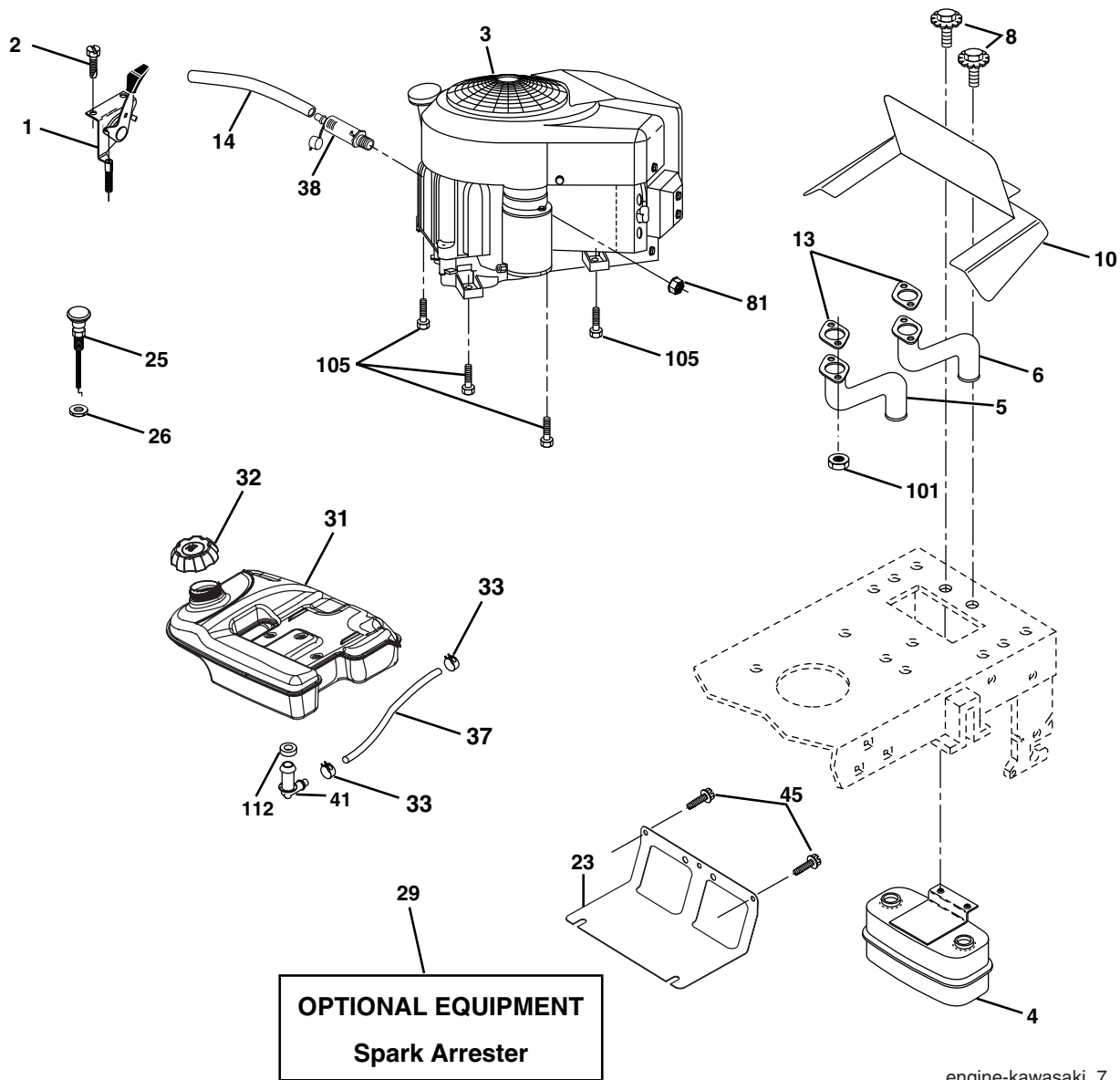

engine-kawasaki_7

KEY NO.	PART NO.	DESCRIPTION
1	532 17 83-85	Control Throttle Flg
2	532 17 18-75	Screw HWHD Hi-Low # 13-16 x 5/8
3	-----	Engine KAWA FH430V (Order Parts from Engine Manufacturer)
4	532 14 97-23	Muffler Asm Twin Lo-Tone
5	532 18 14-44	Exhaust Tube Lh
6	532 18 14-42	Exhaust Tube Rh
8	532 17 18-77	Bolt 5/16-18 unc x 3/4 W/Sems
10	532 14 66-29	Shield Browning
13	-----	Gasket Muffler (Order from Engine Manufacturer)
14	532 14 84-56	Tube Drain Oil Easy
23	532 16 98-37	Shield Browning
25	532 17 86-39	Control Choke
26	873 92 06-00	Nut, Keps 3/8-24 unf
29	532 13 71-80	Kit Spark Arrestor (Flat Scrn)

KEY NO.	PART NO.	DESCRIPTION
31	532 17 90-22	Tank Fuel
32	532 18 18-03	Cap Asm Fuel
33	532 12 34-87	Clamp Hose Blk
37	532 14 21-58	Line Fuel
38	-----	Plug Drain Oil Easy (Order Parts from Engine Manufacturer)
41	532 13 92-77	Stem Tank Fuel
45	817 00 06-12	Screw Hexwsh Thdr 3/8-16 x 3/4
81	873 51 04-00	Nut Keps Hex 1/4-20
101	532 18 43-62	Nut Flange M8-1.25
105	817 12 06-16	Screw 3/8-16 x 1
112	532 12 49-52	Bushing

NOTE: All component dimensions given in U.S. inches
1 inch = 25.4 mm

REPAIR PARTS

TRACTOR - MODEL NO. YTH1542XP (HAU15H42F), PRODUCT NO. 954 17 02-25
SEAT ASSEMBLY

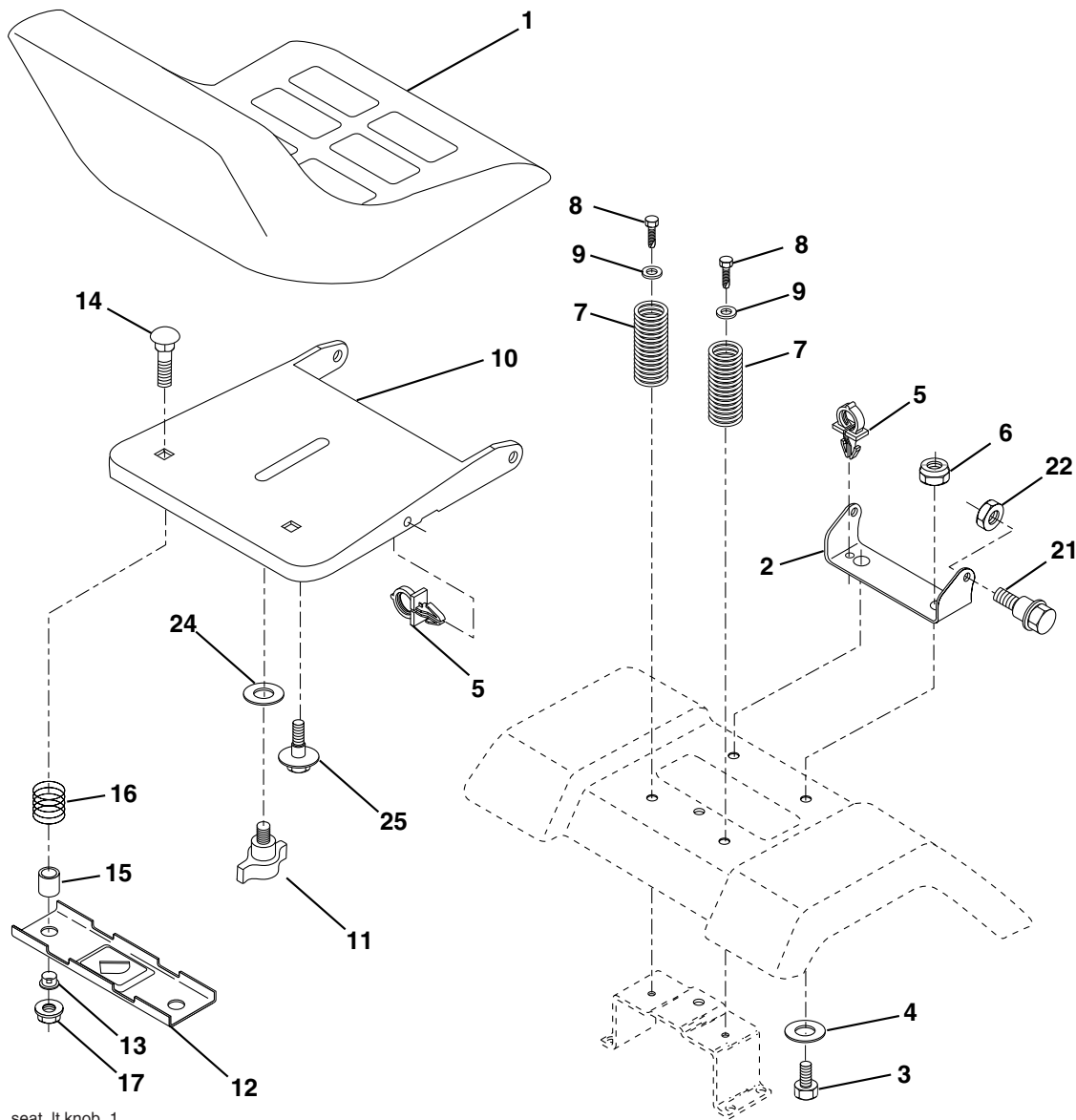

seat_lt.knob_1

KEY NO.	PART NO.	DESCRIPTION
1	532 18 49-95	Seat
2	532 14 05-51	Bracket Pivot Seat 8 720
3	871 11 06-16	Bolt Fin Hex 3/8-16 x 1
4	819 13 16-10	Washer Flat 13/32 x 1.0 x 10 Ga.
5	532 14 50-06	Clip Push-In
6	873 80 06-00	Nut Hex w/Ins. 3/8-16 unc
7	532 12 41-81	Spring Seat Cprsn 2 250 Blk Zi
8	817 00 06-16	Screw 3/8-16 x 1
9	819 13 16-14	Washer 13/32 x 1.0 x 14 Ga.
10	532 18 24-93	Pan Seat
11	532 16 63-69	Knob Seat Adj Wingnut
12	532 12 12-46	Bracket Mounting Switch
13	532 12 12-48	Bushing Snap Blk Nyl 50 Id

KEY NO.	PART NO.	DESCRIPTION
14	872 05 04-12	Bolt Rdhd Sqnk 1/4-20 x 1-1/2
15	532 12 12-49	Spacer Split 28 x .88 Zinc
16	532 12 37-40	Spring Cprsn Plate
17	532 12 39-76	Nut Lock 1/4 Lge Flg Gr. 5 Zinc
21	532 17 18-52	Bolt Shoulder 5/16-18 unc
22	873 80 05-00	Nut Hex Lock W/Ins 5/16-18
24	819 17 19-12	Washer 17/32 x 1 -3/16 x 12 Ga.
25	532 12 70-18	Bolt Shoulder 5/16-18 x 62

NOTE: All component dimensions given in U.S. inches.
1 inch = 25.4 mm

REPAIR PARTS

TRACTOR - MODEL NO. YTH1542XP (HAU15H42F), PRODUCT NO. 954 17 02-25
DECALS

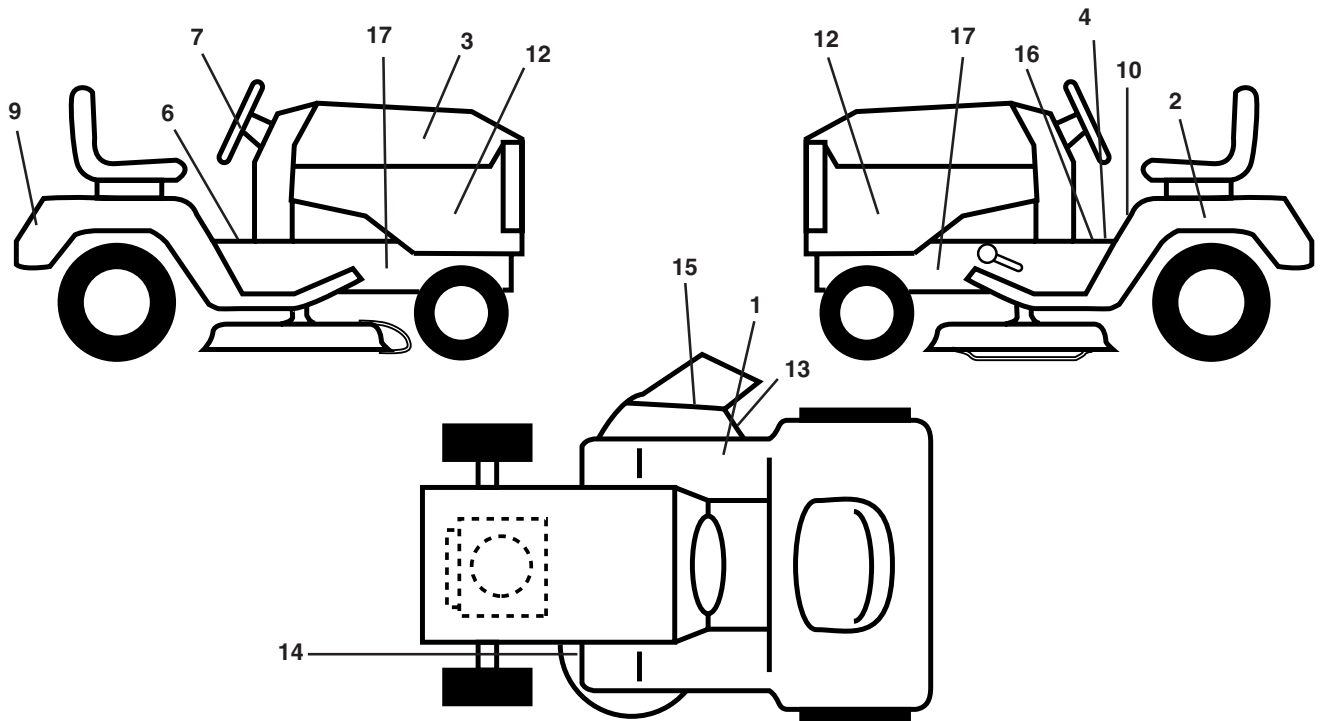

KEY NO.	PART NO.	DESCRIPTION
1	532 16 88-69	Decal Tick Mark
2	532 14 50-05	Decal Battery
3	532 18 89-21	Decal Hood
4	532 17 83-02	Decal Operator Cruise
6	532 14 08-37	Decal Brake Parking
7	532 18 89-25	Decal Wheel Steering
9	532 18 99-14	Decal Fender Husq
10	532 14 54-98	Decal Read Owner's Manual Syms
12	532 18 51-84	Decal Hood
13	532 18 21-66	Decal Cutoffinger
14	532 16 03-96	Decal V-Belt Schematic

KEY NO.	PART NO.	DESCRIPTION
15	532 17 91-28	Decal Deck "B" 42"
16	532 15 97-37	Decal Brake/Clutch Symbol
17	532 15 97-36	Decal Chassis Hot Muffler
--	532 16 25-98	Decal Draw Bar Load Limit
--	532 18 14-95	Pad Footrest LH
--	532 18 14-96	Pad Footrest RH
--	532 16 69-60	Decal By Pass Hydro
--	532 19 00-29	Manual Owner's (English)

WHEELS & TIRES

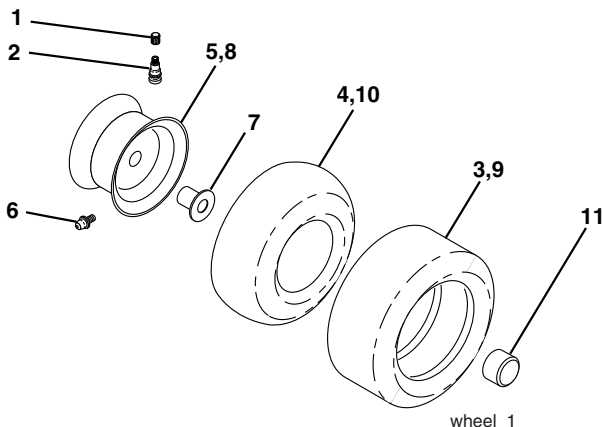

KEY NO.	PART NO.	DESCRIPTION
1	532 05 91-92	Cap Valve Tire
2	532 06 51-39	Stem Valve
3	532 10 62-22	Tire F Ts 15 x 6 0 - 6 Service
4	532 05 99-04	Tube Front (Service Item Only)
5	532 13 83-36	Rim Asm 6" front Silver Service
6	532 12 49-57	Fitting Grease (Front Wheel Only)
7	532 12 49-59	Bearing Flange (Front Wheel Only)
8	532 13 83-37	Rim Asm 8" rear Silver Service
9	532 12 20-82	Tire R Ts 20 x 10-8 C Service
10	532 12 49-26	Tube Rear (Service Item Only)
11	532 17 50-39	Cap Axle Blk 1 50 x 1 00
--	532 14 43-34	Sealant, Tire (10 oz. Tube)

NOTE: All component dimensions given in U.S. inches
1 inch = 25.4 mm

REPAIR PARTS

TRACTOR - MODEL NO. YTH1542XP (HAU15H42F), PRODUCT NO. 954 17 02-25
MOWER LIFT

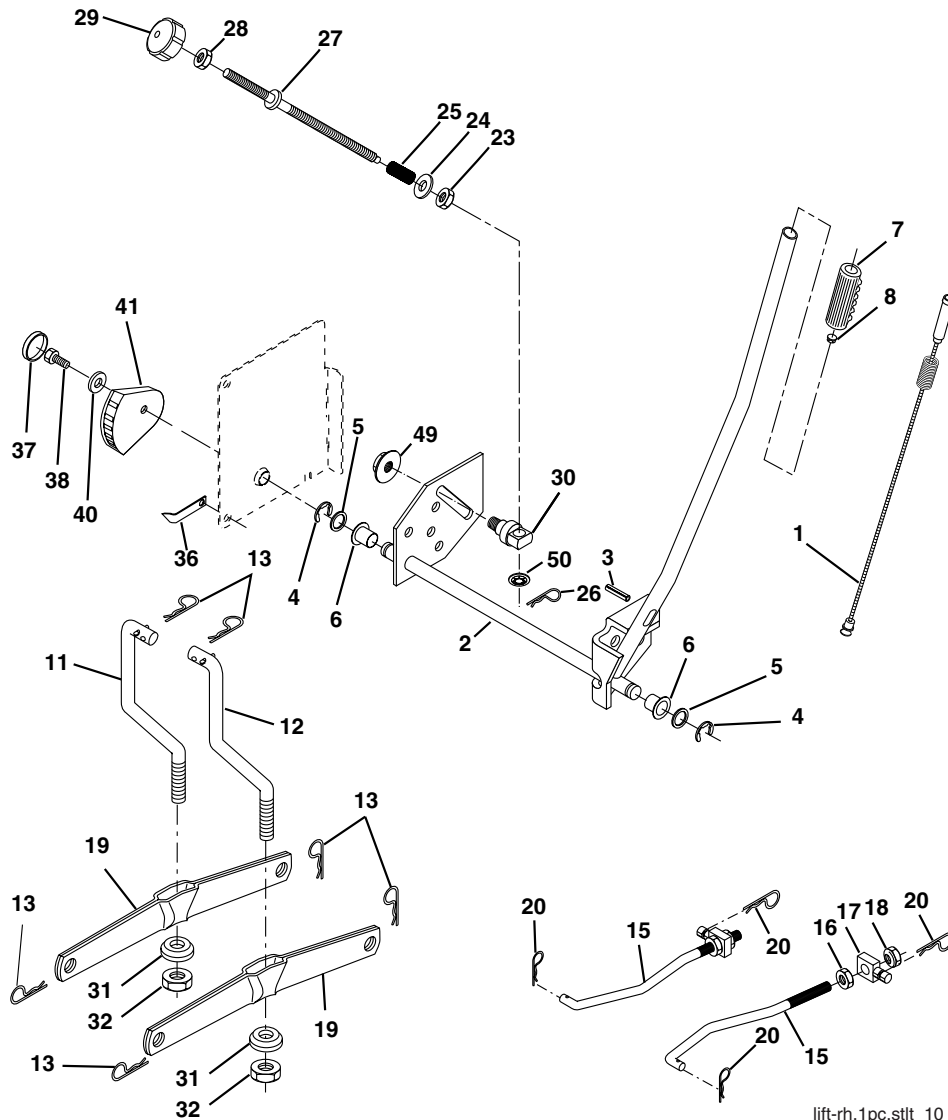

lift-rh.1pc.stlt_10

KEY NO.	PART NO.	DESCRIPTION
1	532 15 94-61	Wire Asm Inner/Spring W/Plunger LT
2	532 15 94-76	Shaft Asm Lift RH w/Inf
3	532 17 89-81	Pin Groove
4	812 00 00-02	E Ring # 5133-62
5	819 21 16-21	Washer 21/32 x 1 x 21 Ga.
6	532 12 01-83	Bearing Nylon Blk 629 Id
7	532 12 56-31	Grip Handle Fluted Blk
8	532 12 45-26	Button Plunger Black
11	532 13 98-65	Link Lift LH
12	532 13 98-66	Link Lift RH
13	532 12 46-70	Retainer Spring
15	532 17 32-88	Link Front
16	873 35 08-00	Nut Jam Hex 1/2-13 unc
17	532 17 56-89	Trunnion
18	873 80 08-00	Nut Lock w/Wsh 1/2-13 unc
19	532 13 98-68	Arm Suspension Rear
20	532 16 35-52	Retainer Spring
23	532 11 08-07	Nut Special
24	819 13 10-16	Washer 13/32 x 5/8 x 16 Ga.

KEY NO.	PART NO.	DESCRIPTION
25	532 16 40-24	Spring
26	532 16 94-84	Retainer Clip
27	532 16 45-43	Rod Adj Lift
28	873 35 06-00	Nut Hex Jam 3/8-16 unc
29	532 13 80-57	Knob Inf 3/8-16 unc Blk W/sym
30	532 15 02-33	Trunnion Infin Height
31	532 16 98-65	Bearing PVT Lift
32	873 54 06-00	Nut Crownlock 3/8-24
36	532 15 50-97	Indicator Height STLT
37	532 12 39-35	Plug Hole Blk 1.485/1.515 Dia.
38	817 06 05-16	Screw 5/16-18 x 1
40	819 11 24-10	Washer 11/32 x 1-1/2 10 Ga.
41	532 15 50-98	Scale Ind. Height Blk.
49	532 14 52-12	Nut Hex Flange Lock
50	532 11 04-52	Nut, Push Phos & Oil

NOTE: All component dimensions given in U.S. inches
1 inch = 25.4 mm

REPAIR PARTS

TRACTOR - MODEL NO. YTH1542XP (HAU15H42F), PRODUCT NO. 954 17 02-25
MOWER DECK

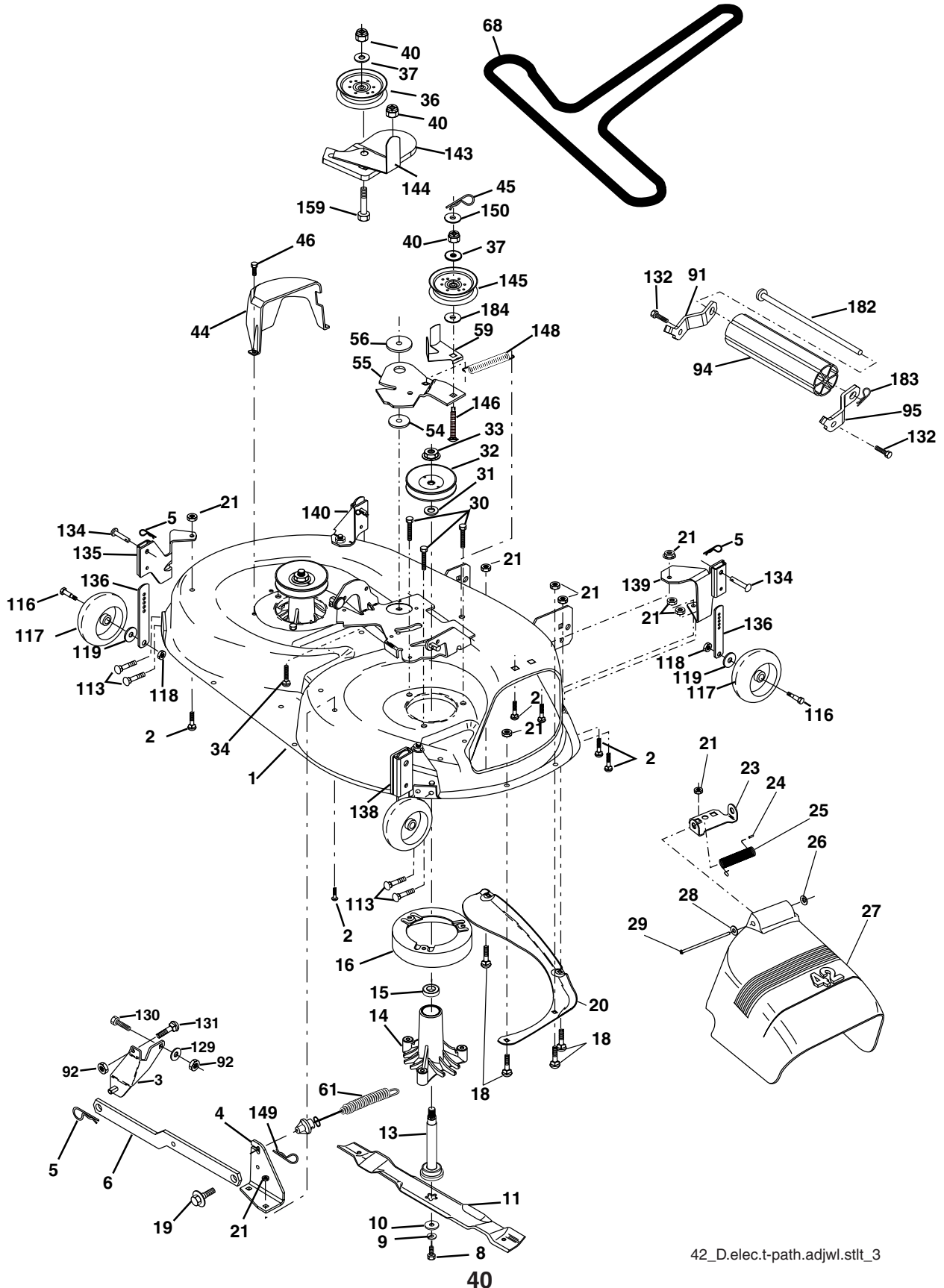

REPAIR PARTS

TRACTOR - MODEL NO. YTH1542XP (HAU15H42F), PRODUCT NO. 954 17 02-25
MOWER DECK

KEY NO.	PART NO.	DESCRIPTION	KEY NO.	PART NO.	DESCRIPTION
1	532 18 54-38	Mower Deck Assembly, 42"	68	532 17 48-83	V-Belt
2	872 14 05-06	Bolt	91	532 18 05-32	Bracket Asm Noseroller Lh
3	532 13 80-17	Bracket Assembly,Sway Bar, Front	92	873 80 06-00	Nut Lock Hex 3/8-16
4	532 16 54-60	Bracket Sway Bar 42" Deck	94	532 13 22-64	Roller Nose 38"-50"
5	532 12 46-70	Retainer Spring	95	532 18 05-33	Bracket Asm Noseroller Rh
6	532 17 80-24	Bar Sway Deck	113	817 06 05-12	Screw 5/16-18 x 3/4 Tap R
8	532 85 08-57	Bolt, Hex 3/8-24 x 1.25 Gr. 8	116	532 18 42-19	Bolt, Shoulder
9	810 03 06-00	Washer, Lock	117	532 13 39-57	Wheel, Gauge
10	532 14 02-96	Washer, Hardened	118	873 93 06-00	Nut, Centerlock 3/8-16
11	532 13 89-71	Blade Mower	119	819 12 14-14	Washer 3/8 x 7/8 x 14 Ga.
13	532 13 76-45	Shaft Assembly, Mandrel, Vented	129	819 13 13-12	Washer 13/32 x 13/16 x Ga.
14	532 12 87-74	Housing, Mandrel, Vented	130	874 78 06-16	Bolt Fin Hex 3/8-16 unc x 1 Gr.5
15	532 11 04-85	Bearing, Ball, Mandrel	131	872 14 06-08	Bolt Rdhd Sqnk 3/8-16 unc x 1
16	532 17 44-93	Stripper	132	817 00 06-12	Screw 3/8-16 x .75
18	872 14 05-05	Bolt, Carriage 5/16-18 x 5/8	134	532 15 69-41	Pin Head Rivet
19	532 13 28-27	Bolt, Shoulder	135	532 17 80-74	Bracket Asm Whl GA R LH
20	532 15 97-70	Baffle, Vortex	136	532 15 59-86	Bar Adjusting GA WHL
21	873 68 05-00	Nut Crownlock 5/16-18 unc	138	532 17 80-75	Bracket Asm Whl GA R RH
23	532 17 75-63	Bracket, Deflector	139	532 17 80-77	Bracket Asm Whl GA F RH
24	532 10 53-04	Cap, Sleeve	140	532 17 80-76	Bracket Asm Whl GA F LH
25	532 12 37-13	Spring, Torsion, Deflector	143	532 15 71-09	Bracket Arm Idler 42"
26	532 11 04-52	Nut, Push	144	532 17 34-41	Keeper Belt 42" Clutch Cable
27	532 17 18-59	Shield, Deflector	145	532 17 34-37	Pulley Idler Flat
28	819 11 10-16	Washer 11/32 x 5/8 x 16 Ga.	146	532 17 34-43	Bolt Carriage Idler
29	532 13 14-91	Rod, Hinge	148	532 16 90-22	Spring Return Idler
30	532 17 39-84	Screw Thdrol Hex	149	532 16 58-98	Retainer Spring Yellow Zinc
31	532 18 76-90	Washer, Spacer	150	819 09 12-10	Washer 9/32 x 3/4 x 10 Ga.
32	532 17 34-36	Pulley, Mandrel	159	872 14 06-14	Bolt Rdhd Sqn 3/8-16 unc x 1- 3/4
33	532 17 83-42	Nut, Toplock, Flanged	182	532 17 91-26	Rod Roller Nose
34	872 11 06-12	Bolt	183	532 16 35-52	Retainer Spring
36	532 17 34-38	Pulley, Idler, Flat	184	819 13 14-10	Washer 13/32 x 7/8 x 10 Ga.
40	873 90 06-00	Nut Lock Fig. 3/8-16 unc	--	532 13 07-94	Mandrel Assembly (Includes Housing, Shaft and Shaft Hardware Only - Pulley Not Included)
44	532 14 00-88	Guard, Mandrel, L.H.	--	532 17 60-50	Replacement Mower, Complete (Std. Deck-Order separately nose roller and guage wheel components key nos. 91, 94, 95, 132, 182, 183 and 5, 116-119)
45	532 12 47-88	Retainer			
46	532 13 77-29	Screw, Thd. Roll 1/4-20 x 5/8			
54	532 17 85-15	Washer, Hardened			
55	532 15 50-46	Arm, Idler			
56	532 12 20-52	Spacer, Retainer			
59	532 17 34-42	Guard, TUV Idler			
61	532 17 48-82	Spring Ext Elect Clutch 42" Dck			

NOTE: All component dimensions given in U.S. inches
1 inch = 25.4 mm