

GTH2548XP

Spare parts

Ersatzteile

Pièces détachées

Reserve onderdelen

Repuestos

Reservdelar

TRACTOR - MODEL NO. GTH2548XP (HAU25H48B), PRODUCT NO. 954 17 00-87

SCHEMATIC

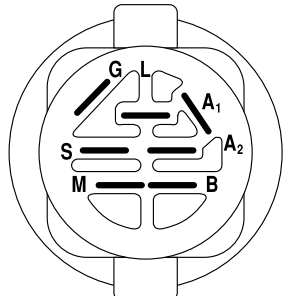
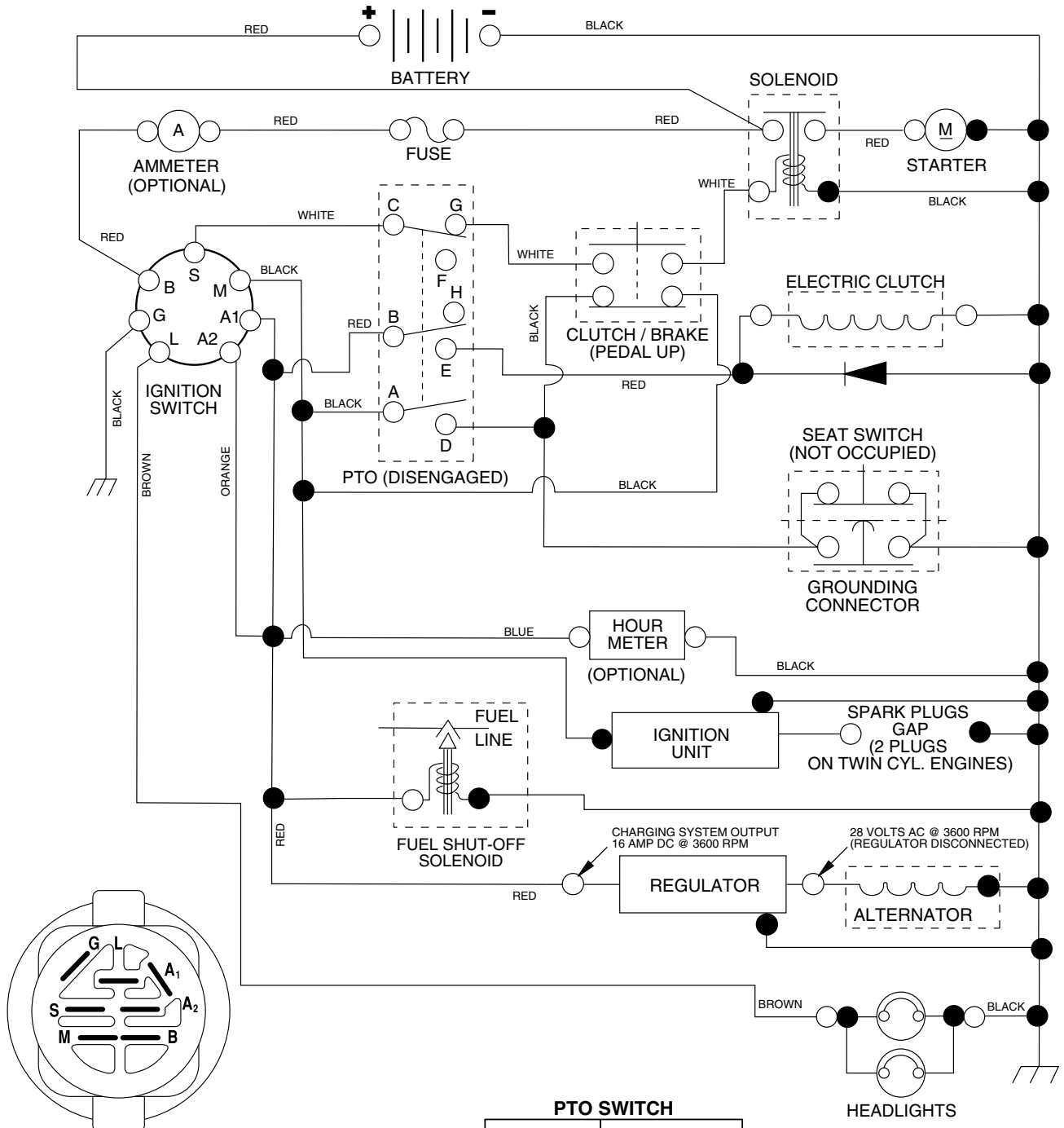

IGNITION SWITCH

POSITION	CIRCUIT	"MAKE"
OFF	M + G + A1	NONE
ON + LIGHTS	B + A1	L + A2
ON	B + A1	NONE
START	B + S + A1	NONE

WIRING INSULATED CLIPS
NOTE: IF WIRING INSULATED CLIPS WERE REMOVED FOR SERVICING OF UNIT, THEY SHOULD BE REPLACED TO PROPERLY SECURE YOUR WIRING.

PTO SWITCH

POSITION	CIRCUIT
OFF	C + G, B + H
ON	C + F, B + E, A + D

○ ——— ○
 REMOVABLE CONNECTIONS

● ——— ●
 NON-REMOVABLE CONNECTIONS

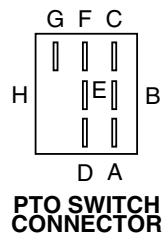

REPAIR PARTS

TRACTOR - MODEL NO. GTH2548XP (HAU25H48B), PRODUCT NO. 954 17 00-87

ELECTRICAL

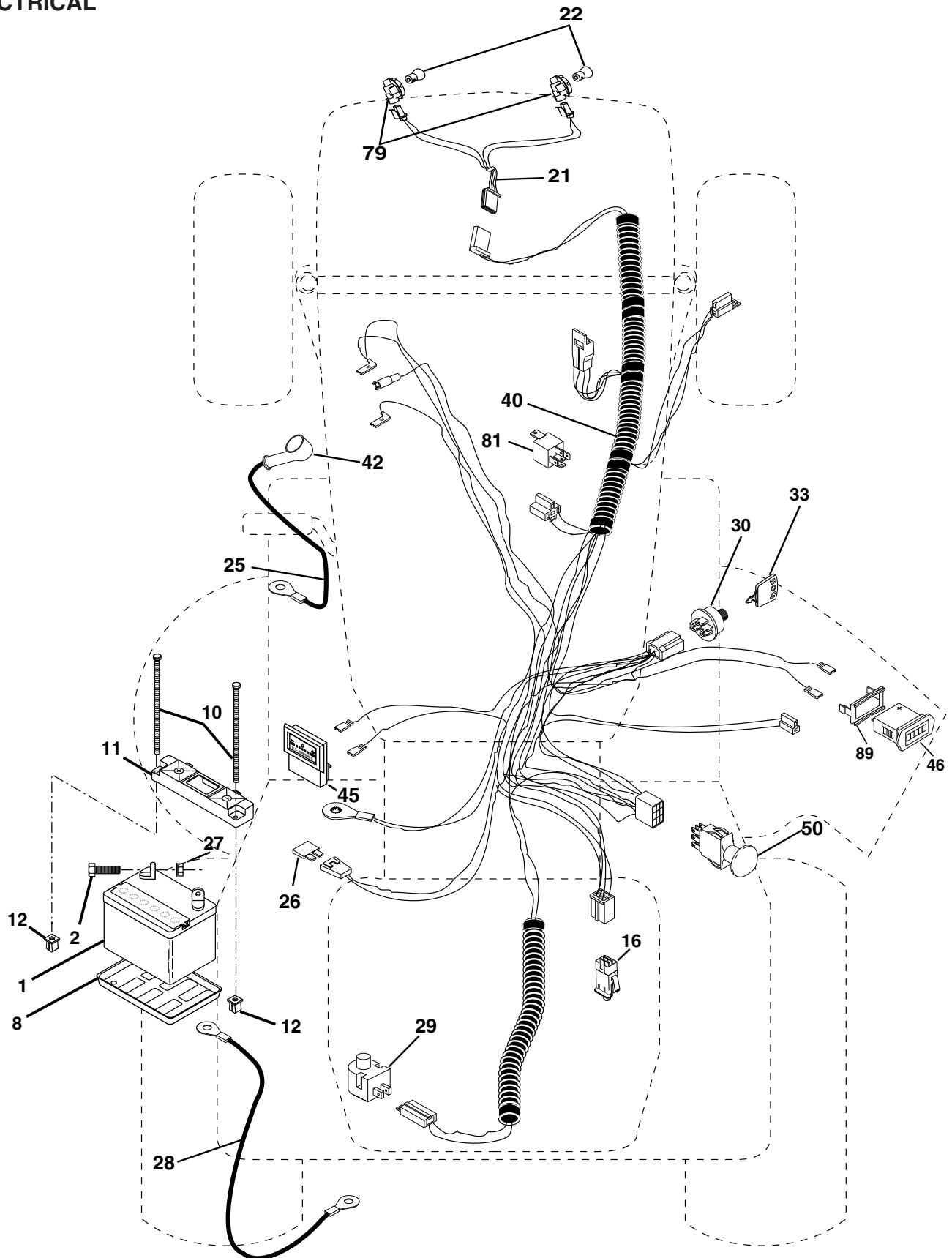

REPAIR PARTS

TRACTOR - MODEL NO. GTH2548XP (HAU25H48B), PRODUCT NO. 954 17 00-87

ELECTRICAL

KEY NO.	PART NO.	DESCRIPTION
1	532 14 49-27	Battery
2	874 76 04-12	Bolt Hex Head 1/4-20 x 3/4
8	532 12 48-86	Tray, Battery
10	532 14 52-11	Bolt, Battery Front 1/4-20 x 7.5 Zinc
11	532 15 01-09	Holddown Battery Front Mount
12	532 14 57-69	Nut, Push Nylon 1.4" Battery Front
16	532 17 61-38	Switch Interlock
21	532 17 56-88	Harness Socket Light w/4152J
22	532 00 41-52	Bulb Light
25	532 18 54-61	Cable, Battery
26	532 10 88-24	Fuse
27	873 51 04-00	Nut Keps Hex 1/4-20
28	532 17 06-97	Cable, Ground
29	532 12 13-05	Switch, Plunger NC Gray
30	532 17 55-66	Switch, Ign
33	532 14 04-01	Key
40	532 18 80-32	Harness Ign.
42	532 15 43-36	Cover, Terminal Red
45	532 12 28-22	Ammeter
46	532 16 96-35	Hourmeter Snap-In
50	532 17 46-51	Switch, PTO
79	532 17 52-42	Bulbholder Asm
81	532 10 97-48	Relay Asm.
89	532 16 96-39	Bracket Snap-In Hourmeter

NOTE: All component dimensions given in U.S. inches
1 inch = 25.4 mm

REPAIR PARTS

TRACTOR - MODEL NO. GTH2548XP (HAU25H48B), PRODUCT NO. 954 17 00-87 CHASSIS AND ENCLOSURES

KEY NO.	PART NO.	DESCRIPTION
1	532 18 03-75	Rail, Frame RH
2	532 17 52-82	Drawbar, Gt
5	532 17 75-82	Dash, Plastic
6	532 15 78-82	Dash, 1PCS, Lower
7	817 72 04-08	Screw, Thd Cut 1/4-20 x 1/2
8	532 18 46-68	Support, Battery
14	532 17 75-83	Hood Asm., Pnt
15	532 16 18-41	Lens LH
16	532 12 17-94	Cover, Access
17	817 00 06-12	Screw, 3/8-16 x 3/4
18	532 17 75-84	Grille
19	819 13 13-12	Washer 13/32 x 13/16 x 12 Ga.
20	874 76 06-16	Bolt, Fin Hex 3/8-16 x 1
21	873 80 06-00	Nut, Lock Hex w/ins 3/8-16
24	532 18 10-58	Footrest, RH
25	532 16 18-42	Lens RH
28	532 18 10-57	Footrest, LH
30	532 14 50-52	Saddle
31	532 16 14-19	Bracket Supt 1-pc Vgt Steering
32	532 16 13-27	Bracket, Frame Pivot Lh
33	532 16 13-26	Bracket, Frame Pivot Rh
34	532 17 70-18	Plate Asm Engine Chassis
35	819 11 11-16	Washer 11/32 x 11/16 x 16 Ga.
36	817 06 05-12	Screw 5/16-18 x 3/4
37	532 18 17-20	Fender, Pnt.
39	532 17 52-78	Bracket, Axle Front
43	532 13 69-39	Bracket, Spnsn Front Lh
44	532 13 69-40	Bracket, Spnsn Front Rh
45	532 17 60-18	Bracket Asm., Susp Chassis Rh
47	817 49 06-08	Screw Thdrol 3/8-16 x 1/2
50	532 17 54-76	Bracket, Chassis Front
56	532 17 60-16	Bracket Asm., Susp Chassis Lh
58	532 18 35-69	Bracket Asm., Fender
60	817 06 06-20	Screw 3/8-16 x 1-1/4
68	817 49 05-08	Screw, 5/16-18 x 1/2
86	874 76 07-16	Bolt, Fin Hex 7/16-14 Unc x 1
91	532 18 03-74	Rail, Frame Lh
99	532 17 71-43	Rod Asm. Bypass
115	532 17 03-11	Bumper Asm.
116	532 17 03-10	Bracket Ext. Bumper
117	532 14 36-79	Plug Plastic
122	532 16 14-64	Screw Hex WSHD 8-18 x 7/8
130	532 17 18-75	Screw Hw Hd Hi-Lo #13-16 x 3/4
138	532 18 17-98	Cupholder
139	532 17 18-73	Bolt Shoulder 5/16-18
142	532 16 18-97	Bracket Dash Stealth RH
143	532 17 75-86	Skirt Grille RH
144	532 16 19-00	Bracket Dash Stealth LH
146	532 17 75-87	Skirt Grille LH
148	532 16 46-55	Extrusion Bumper
150	532 16 12-37	Duct Heat Hood
152	532 17 79-56	Shield, Browning
153	532 17 97-65	Light Box Asm w/Lens
156	817 00 05-12	Screw 5/16-18 x 3/4
158	817 67 06-08	Screw 3/8-16 x 1/2
161	532 18 17-87	Consol Fuel Window
162	532 14 24-32	Screw Hex Wsh Hi-Lo 1/4-1/2 Unc
165	532 18 35-54	Bracket Support Fuel Tank
166	873 68 07-00	Nut 7/16-14

NOTE: All component dimensions given in U.S. inches
1 inch = 25.4 mm

REPAIR PARTS

TRACTOR - MODEL NO. GTH2548XP (HAU25H48B), PRODUCT NO. 954 17 00-87

GROUND DRIVE

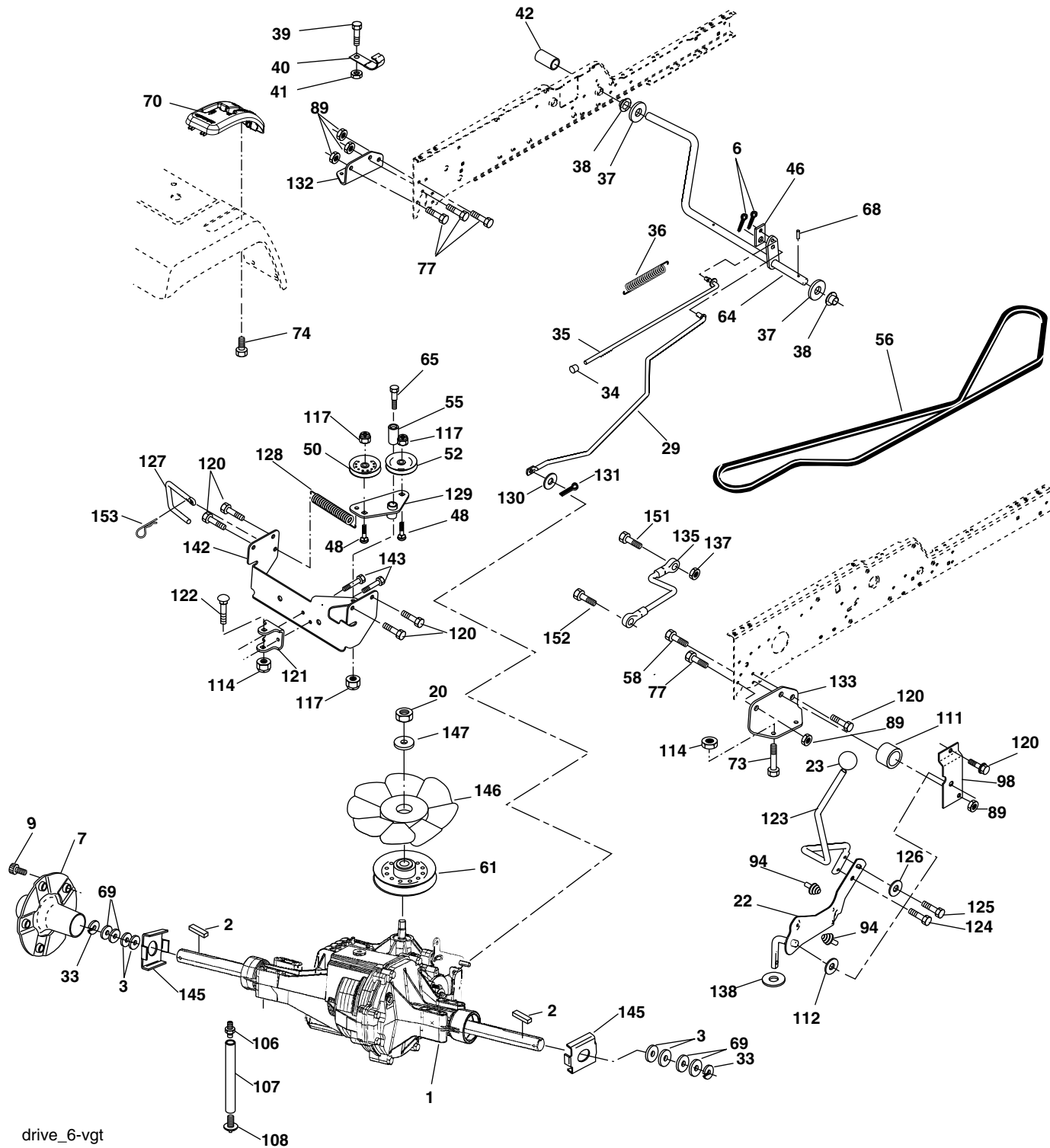

drive_6-vgt

REPAIR PARTS

TRACTOR - MODEL NO. GTH2548XP (HAU25H48B), PRODUCT NO. 954 17 00-87

GROUND DRIVE

KEY NO.	PART NO.	DESCRIPTION	KEY NO.	PART NO.	DESCRIPTION
1	-----	Transaxle Hydro Gear 331-3000 (Order Parts From Transaxle Manufacturer)	89	873 68 07-00	Nut Crownlock 7/16-14 Unc
2	532 00 70-70	Key Sq. 1/4 x 2.5	94	532 13 38-35	Fastener Christmas Tree
3	532 00 75-63	Washer	98	532 14 10-04	Bracket Shift
6	876 02 04-12	Pin, Cotter	106	532 14 29-18	O-Ring Asm Hydro Gear
7	532 14 05-07	Wheel, Hub Assembly	107	532 15 47-39	Line Fuel Hydro 15" VGT
9	532 14 00-80	Bolt, Hub	108	532 14 29-17	Cap Asm Vent Hydro Gear
20	873 94 08-00	Nut	111	532 15 62-40	Spacer Shift Lever VGTH
22	532 18 02-35	Lever Asm Shift	112	532 17 85-58	Washer Nylon High Temp
23	532 14 08-45	Knob	114	873 80 05-00	Nut Lock Hex W/Ins 5/16-18 Unc
29	532 17 66-00	Brake, Rod	117	873 90 06-00	Nut, Lock Flg. 3/8-16
33	812 00 00-53	Ring E	120	817 00 06-12	Screw 3/8-16 x .75
34	532 07 16-73	Cap, Parking Brake	121	532 17 56-11	Bracket Strap Torque
35	532 13 76-48	Rod, Parking Brake	122	872 01 05-20	Bolt RDHDSQ 5/16-18 Unc x 2-1/2
36	532 14 94-12	Spring, Drive Ground	123	532 18 32-54	Rod Shift
37	532 12 17-49	Washer 25/32 x 1-1/4 x 16 Ga.	124	532 16 54-92	Bolt Shoulder 5/16-18 x .561
38	532 15 00-35	Nyliner	125	817 49 05-10	Screw 5/16-18 x 5/8
39	874 32 10-16	Screw, Fin. #10-24 x 1	126	532 16 60-02	Washer SRRTD 5/16 ID x 1.0 x .125
40	532 17 85-75	Actuator, Interlock VGT	127	532 17 73-62	Link Control Clutch
41	873 93 10-00	Nut Centerlock 10-24 Unc	128	532 17 66-24	Spring Drive GRND
42	532 12 47-82	Cover, Pedal	129	532 17 94-73	Bracket Asm Idler Tensioning
46	532 14 51-70	Retainer, Spring	130	819 13 10-16	Washer 13/32 x 5/8 x 16 Ga.
48	872 11 06-14	Bolt Rdhd 3/8-16 x 1.3/4 Gr. 5	131	876 02 03-12	Pin Cotter 3/32 x 3/4
50	532 13 14-94	Pulley, Idler, Flat	132	532 17 54-67	Bracket Mtg Hydro 3500 LH VGT
52	532 12 77-83	Pulley, Idler, Grooved	133	532 17 54-68	Bracket Mtg Hydro 3500 RH VGT
55	532 10 57-06	Bearing, Idler	135	532 17 73-64	Link Asm Control Hydro 3500
56	532 16 15-97	V-Belt	137	532 12 49-49	Nut Lock 5/16-18 NC Thd.
58	874 76 07-24	Bolt Fin Hex 7/16-14 x 1-1/2	138	532 00 13-70	Washer Thrust 5/8 x 1.10 x 1/32
61	532 14 39-95	Pulley, Transaxle	142	532 17 54-69	Strap Torque HG-3500
64	532 17 66-01	Shaft, Brake Pedal	143	817 06 05-12	Screw Thdrol 5/16-18 x 3/4
65	532 17 96-13	Bolt, Shoulder	145	532 16 31-68	Washer Axle Flange HG-3000
68	532 00 51-42	Pin, Roll	146	532 14 04-62	Fan 7" Hydro
69	532 12 38-00	Washer	147	532 14 13-22	Washer
70	532 18 17-88	Console Automatic YT/GT	151	874 76 05-14	Bolt Hex 5/16-18 x 7/8
73	874 49 05-48	Bolt Hex Flghd 5/16-18 x 3 Gr5	152	532 17 87-05	Bolt Hex 5/16 x 1 W/Patch
74	532 14 24-32	Screw Hex Wsh. Hi-Lo 1/4-1/2	153	532 12 47-88	Spring, Retainer
77	874 78 07-16	Bolt Fin Hex 7/16-14 x 1			

NOTE: All component dimensions given in U. S. inches 1 inch = 25.4 mm

REPAIR PARTS

TRACTOR - MODEL NO. GTH2548XP (HAU25H48B), PRODUCT NO. 954 17 00-87

STEERING ASSEMBLY

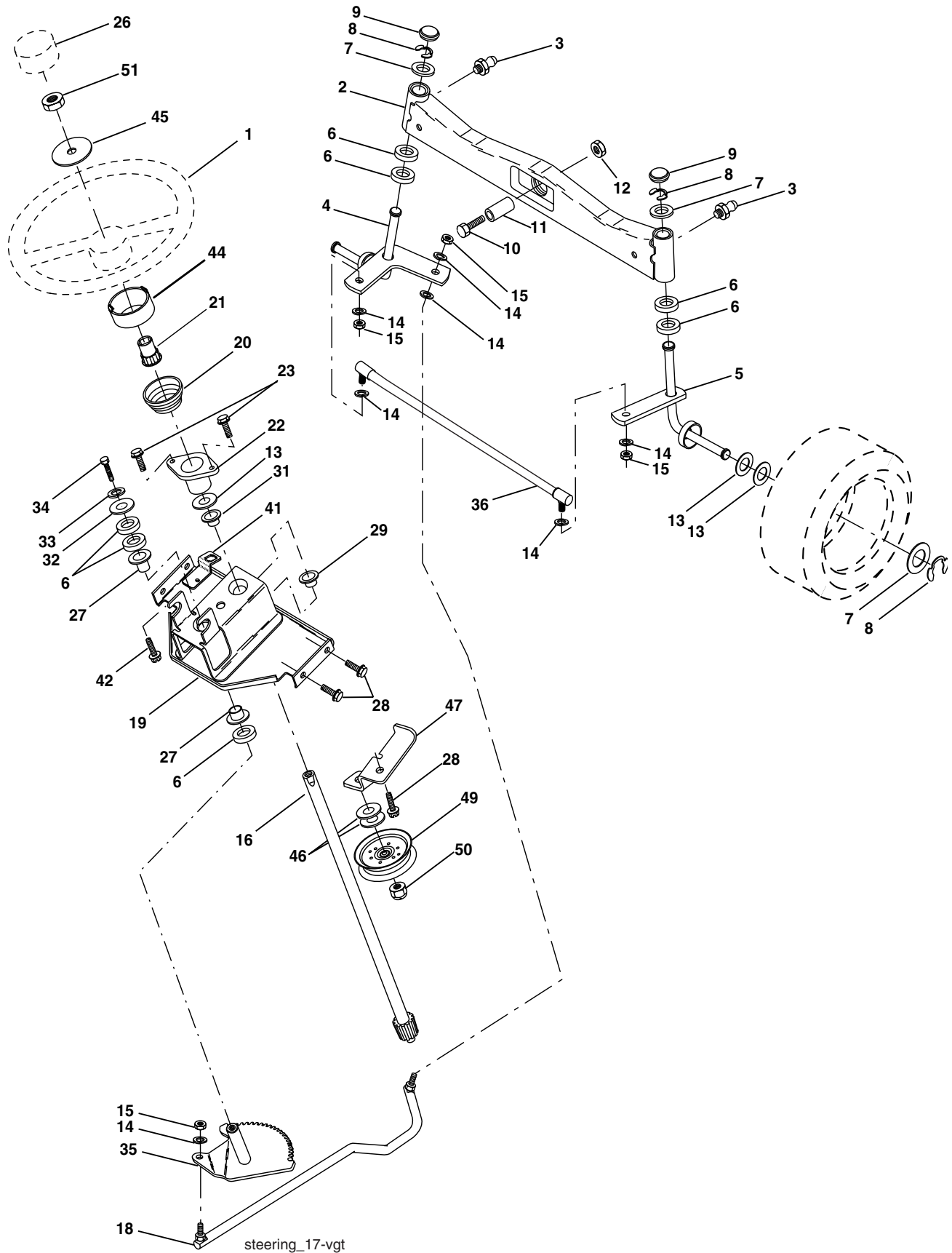

REPAIR PARTS

TRACTOR - MODEL NO. GTH2548XP (HAU25H48B), PRODUCT NO. 954 17 00-87

STEERING ASSEMBLY

KEY NO.	PART NO.	DESCRIPTION
1	532 16 66-27	Wheel, Steering
2	532 17 85-57	Axle Asm., Front
3	532 18 32-66	Fitting, Grease
4	532 16 18-49	Spindle Asm, LH
5	532 16 18-48	Spindle Asm., RH
6	532 12 49-31	Bearing, Race Thrust Harden
7	532 12 17-48	Washer 25/32 x 1-5/8 x 16 Ga.
8	812 00 00-29	Ring, Klip #T5304-75
9	532 12 12-32	Cap, Spindle
10	874 78 10-44	Bolt, Fin Hex 5/8-11 x 2-3/4
11	532 13 65-18	Spacer Brg Axle Front 1.570
12	873 90 10-00	Nut, Lock Flange 5/8-11 Unc
13	532 12 17-49	Washer 25/32 x 1-1/4 x 16 Ga.
14	810 04 06-00	Washer, Lock Hvy Hlcl Spr 3/8
15	873 54 06-00	Nut Crownlock 3/8-24
16	532 18 68-14	Shaft Asm., Steering
17	532 18 67-99	Rod Asm., Tie Ball J Ball Vgt (Inc. Key No. 36-40)
18	532 17 55-72	Draglink, Ball Joint Solid Vgt
19	532 15 60-11	Support Asm., Steering Vgt
20	532 17 75-92	Boot Steering
21	532 15 99-45	Adapter, Wheel Steering
22	532 15 51-05	Bushing, Strg.
23	532 15 29-27	Screw
26	532 16 66-26	Cap , Wheel Steering
27	532 12 49-37	Bearing, Col. Strg.
28	817 00 06-12	Screw 3/8-16 x 3/4
29	532 10 42-39	Bearing, Flange
31	532 13 81-36	Bushing, Nyliner Snap
32	819 11 16-10	Washer 11/32 x 1 x 10 Ga.
33	810 04 05-00	Washer, Lock Hvy Hlcl Spr 5/16
34	874 78 05-12	Bolt, Hex Hd 5/16-18 x 3/4
35	532 18 70-39	Gear, Sector Steering
36	532 13 71-56	Tie Rod
37	873 36 06-00	Jam Nut RH Thread
38	532 10 98-50	Joint Asm. Ball RH Thread
39	873 70 06-00	Nut Hex Jam 3/8-24 UNF LH
40	532 10 98-51	Joint Asm Ball LH
41	532 15 52-46	Bracket Switch Inerlock VGT97
42	817 49 05-08	Screw 5/16-18 x 1/2
44	532 17 75-93	Extension Steering Premium
45	819 18 24-11	Washer 9/16 x 1-1/2 x 11 Ga.
46	819 13 16-10	Washer FLat 13/32 x 1/10 Ga.
47	532 17 94-71	Bracket Asm. Idler
49	532 17 58-20	Pulley Idler Flat
50	873 90 06-00	Nut Lock Flg 3/8-16 Unc
51	873 94 08-00	Nut Hex Jam Toplock 1/2-20
52	532 17 55-53	Clip Steering

NOTE: All component dimensions given in U.S. inches
1 inch = 25.4 mm

REPAIR PARTS

TRACTOR - MODEL NO. GTH2548XP (HAU25H48B), PRODUCT NO. 954 17 00-87

ENGINE

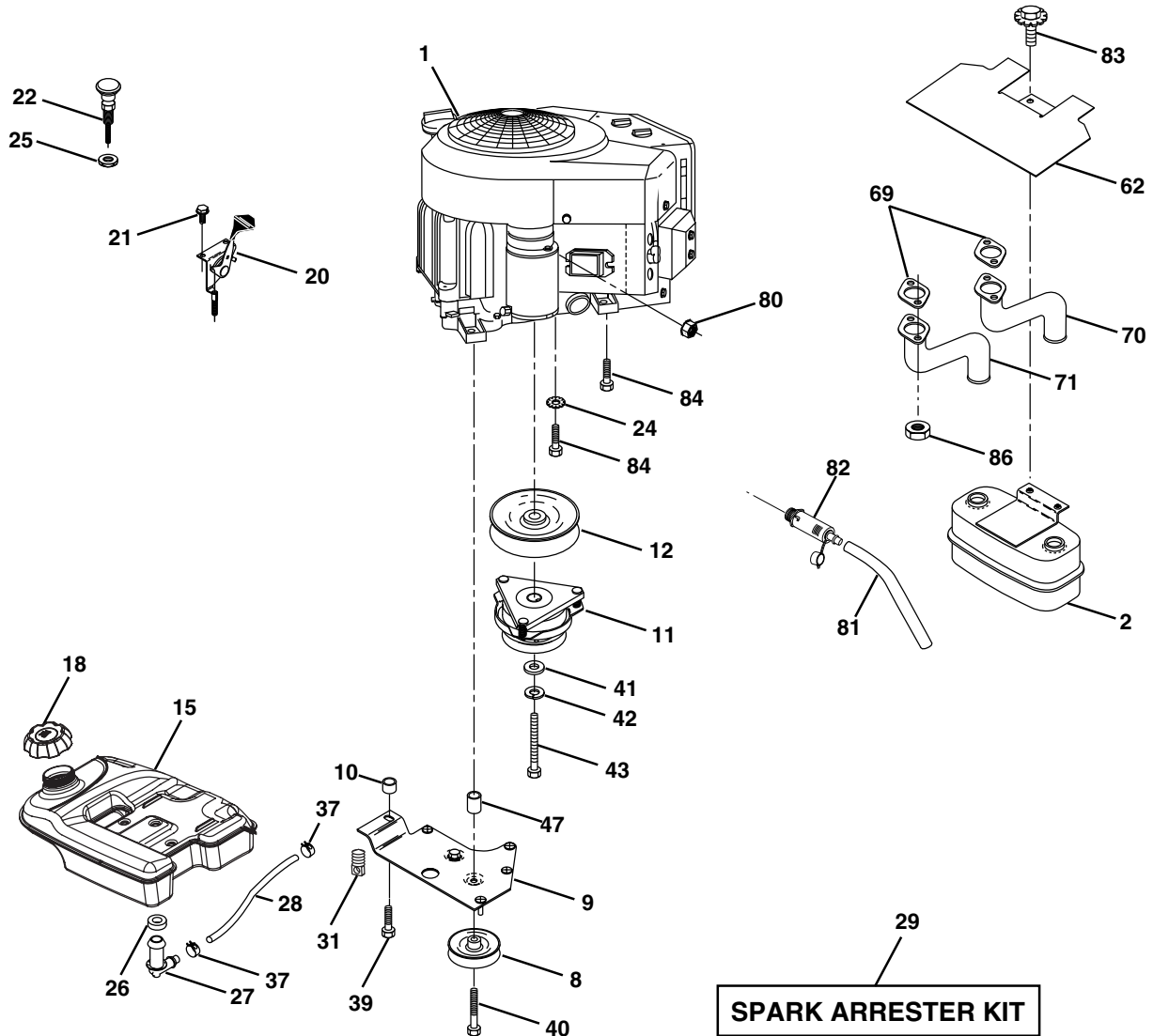

engine-kawasaki_3 vgt

KEY NO.	PART NO.	DESCRIPTION
1	---	Engine Kawasaki, Model No. FH721V (Order parts from engine manufacturer)
2	532 14 97-23	Muffler Side
8	532 12 13-61	Pulley V-Idler
9	532 17 77-48	Keeper Asm. Belt Engine VGT
10	532 17 52-87	Bushing
11	532 17 93-35	Clutch Oqura
12	532 14 39-96	Pulley Engine VGT Elect Clutch
15	532 17 91-15	Tank Fuel
18	532 18 18-03	Cap Fuel
20	532 17 81-47	Control Throttle
21	532 17 18-75	Screw HWHD Hi-Lo #13-16 x 5/8
22	532 17 81-48	Control Choke
24	811 05 06-00	Washer Ext Tooth 3/8
25	873 92 06-00	Nut Keps 3/8-24 Unf
26	532 12 49-52	Bushing
27	532 13 92-77	Stem Tank Fuel
28	532 00 71-19	Fuel Line
29	532 13 71-80	Spark Arrester Kit
31	532 14 50-06	Clip Push-In Hinged
35	810 01 05-00	Washer

KEY NO.	PART NO.	DESCRIPTION
37	532 12 34-87	Clamp Hose
39	817 49 06-36	Screw TT 3/8-16 x 2-1/4 UNC
40	817 49 06-64	Screw TT 3/8-16 x 4 UNC
41	532 12 61-97	Washer 1-1/2 OD X 15/32 ID X .250
42	810 04 07-00	Washer Lock 7/16
43	532 17 99-53	Bolt Hex 7/16-20 X 3.75 Gr. 5
47	532 17 52-88	Bushing
62	532 17 62-52	Shield Heat Muffler
69	---	Gasket (Order from engine mfg.)
70	532 17 57-67	Tube Exhaust RH
71	532 17 57-66	Tube Exhaust LH
80	532 16 33-05	Nut Flange M8-1.25
81	532 14 84-56	Tube Drain Oil Easy
82	---	Plug Drain Oil (Order from engine mfg.)
83	532 17 18-77	Bolt 5/16-18unc X 1-3/4 W/Sems
84	817 06 06-24	Screw 3/8-16 x 1-1/2
86	532 18 43-62	Nut Hex Flange Toplock M8-1.25

NOTE: All component dimensions given in U.S. inches
1 inch = 25.4 mm

REPAIR PARTS

TRACTOR - MODEL NO. GTH2548XP (HAU25H48B), PRODUCT NO. 954 17 00-87
SEAT ASSEMBLY

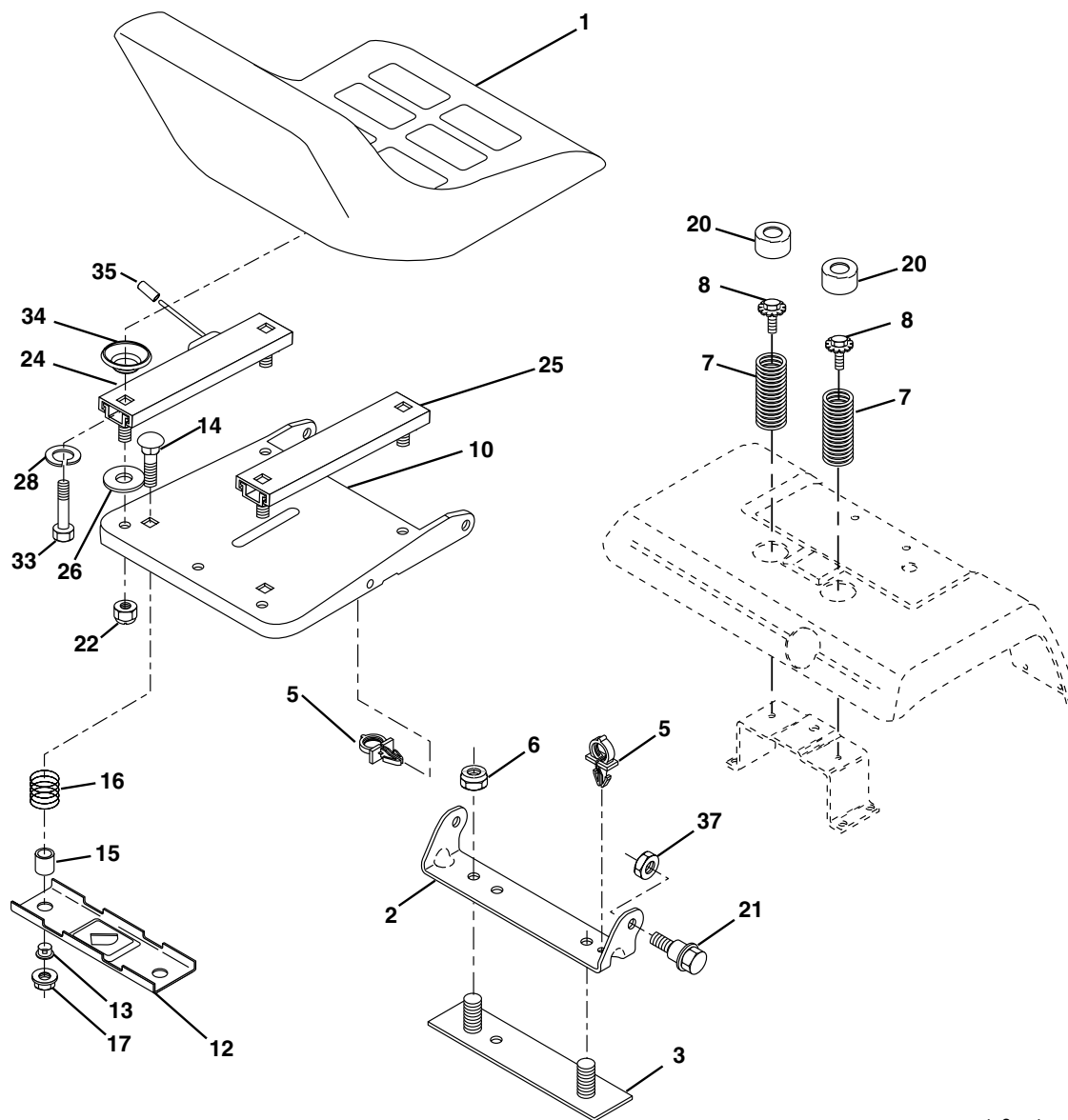

seat_9-vgt

KEY NO.	PART NO.	DESCRIPTION	KEY NO.	PART NO.	DESCRIPTION
1	532 12 41-87	Seat	17	532 12 39-76	Nut, Lock 1/4 Lge Flg Gr. 5
2	532 14 05-51	Bracket, Pivot Seat	20	532 12 42-38	Cap, Spring Seat
3	532 14 06-75	Strap, Fender	21	532 17 18-52	Bolt, Shoulder 5/16-18
5	532 14 50-06	Clip, Push In Hinged	22	873 68 05-00	Nut, Crownlock 5/16-18
6	873 80 06-00	Nut, Crownlock 3/8-16	24	532 17 79-46	Track Slide Seat LH Locking
7	532 12 41-81	Spring, Seat Cprsn	25	532 17 79-47	Track Slide Seat RH Free
8	532 17 18-77	Bolt 5/16-18 UNC X 3/4	26	819 11 10-12	Washer 11/32 x 5/8 x 12 Ga.
10	532 18 24-93	Pan, Seat	28	810 01 05-00	Washer Split
12	532 12 12-46	Bracket, Mounting Switch	33	874 78 05-16	Bolt Fin Hex 5/16-18 x 1
13	532 12 12-48	Bushing, Snap	34	532 12 44-27	Spacer
14	872 05 04-12	Bolt, Carriage 1/4-20 X 1-1/2	35	532 17 84-26	Cap Vinyl
15	532 12 12-49	Spacer, Split	37	873 80 06-00	Nut 3/8-16
16	532 12 37-40	Spring, Cprsn			

NOTE: All component dimensions given in U.S. inches
1 inch = 25.4 mm

REPAIR PARTS

TRACTOR - MODEL NO. GTH2548XP (HAU25H48B), PRODUCT NO. 954 17 00-87

DECALS

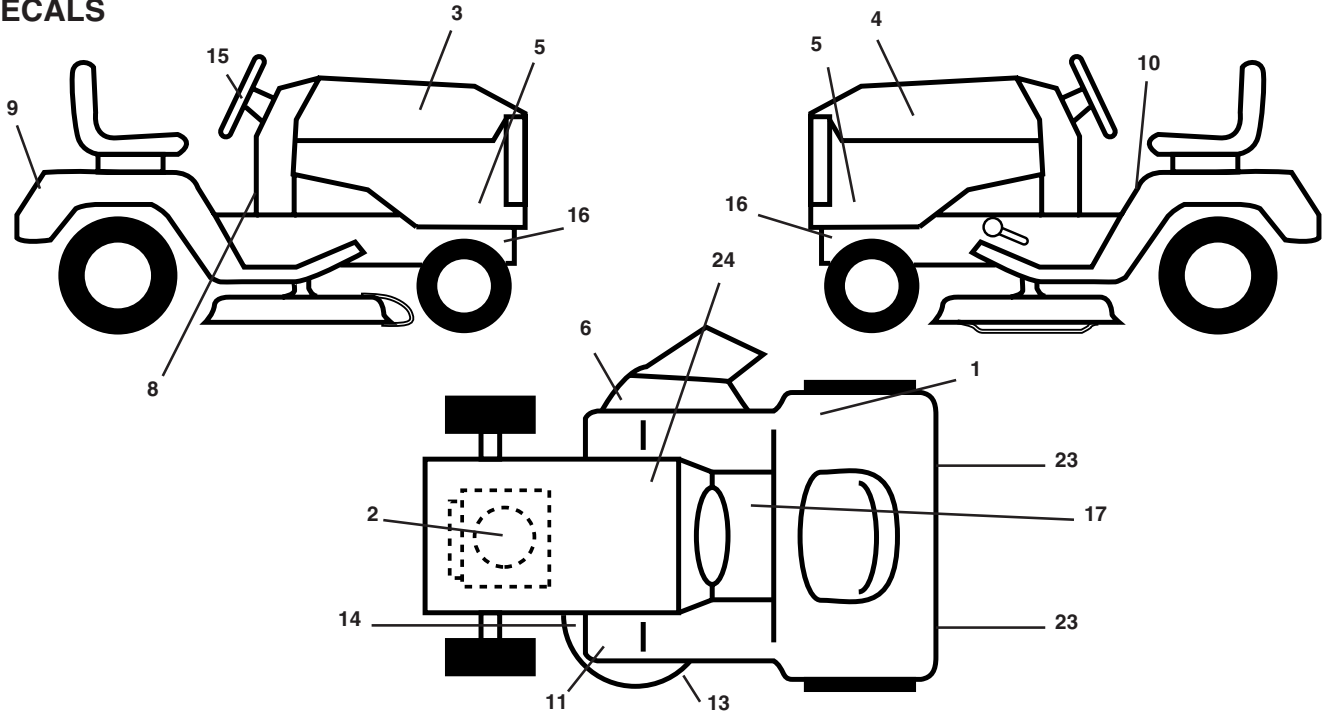

KEY NO.	PART NO.	DESCRIPTION
1	532 16 88-69	Decal, Tick Mark
2	532 18 00-95	Decal, Engine
3	532 18 16-60	Decal, Hood, RH
4	532 18 16-61	Decal, Hood, LH
5	532 18 00-91	Decal, Side Panel
6	532 18 21-66	Decal, Warning Cutfinger
8	532 17 68-64	Decal, Dash
9	532 17 68-22	Decal, Fender
10	532 14 54-98	Decal, Read Owners Manual
11	532 18 12-53	Decal, Foot Rest
13	532 17 52-91	Decal, V-Belt Sch
14	532 17 85-02	Decal, Caution
15	532 17 05-64	Decal, Ins. Strg Whl

KEY NO.	PART NO.	DESCRIPTION
16	532 15 97-36	Decal, Hot Muffler
17	532 14 08-37	Decal, Saddle Brake Parking
23	532 10 62-02	Reflector, Taillight
24	532 14 50-05	Decal, Btry Dngr/Psn
--	532 16 69-60	Decal, Drawbar
--	532 16 25-98	Decal, Drawbar Load Limit
--	532 18 19-17	Pad Footrest RH
--	532 18 19-16	Pad Footrest LH
--	532 18 86-43	Manual, Owner's (English)

WHEELS & TIRES

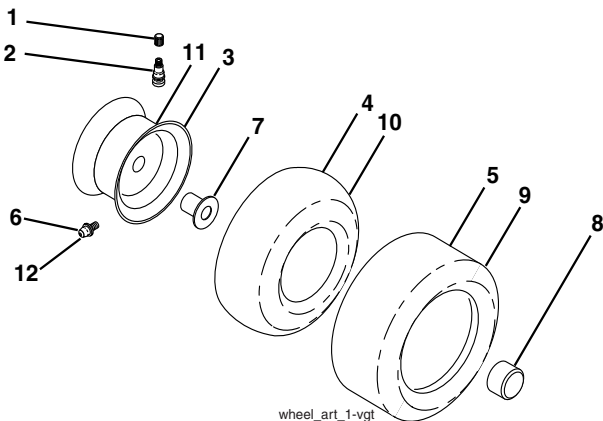

KEY NO.	PART NO.	DESCRIPTION
1	532 05 91-92	Cap, Valve, Tire
2	532 06 51-39	Stem, Valve
3	532 14 45-09	Rim Assembly, Front
4	532 00 81-34	Tube, Front (Service Item Only)
5	532 10 62-30	Tire, Front
6	532 12 49-57	Fitting, Grease
7	532 12 49-59	Bearing, Flange (Front Wheel Only)
8	532 17 50-39	Cap, Hub
9	532 10 55-88	Tire, Rear
10	532 00 71-54	Tube, Rear (Service Item Only)
11	532 14 45-10	Rim Assembly, Rear
12	532 12 48-60	Fitting, Grease
--	532 14 43-34	Sealant, Tire (10 oz. Tube)

NOTE: All component dimensions given in U.S. inches
1 inch = 25.4 mm

REPAIR PARTS

TRACTOR - MODEL NO. GTH2548XP (HAU25H48B), PRODUCT NO. 954 17 00-87

LIFT ASSEMBLY

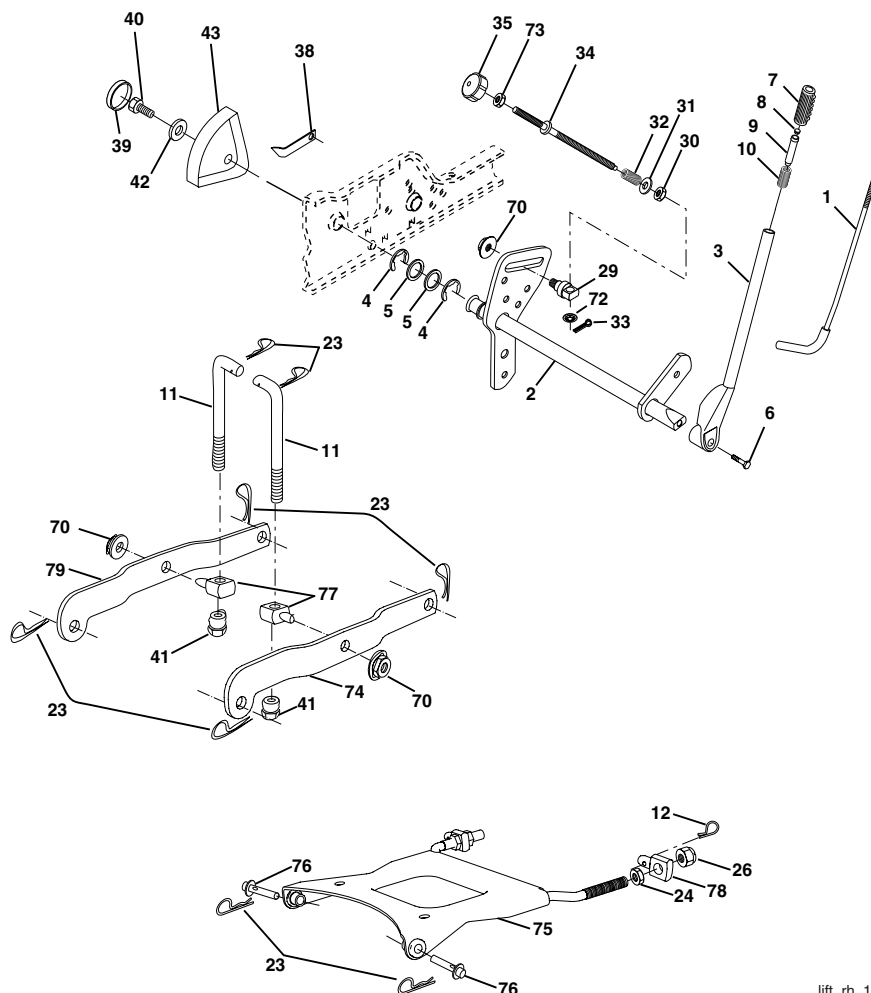

lift_rh_15

KEY NO.	PART NO.	DESCRIPTION	KEY NO.	PART NO.	DESCRIPTION
1	532 12 10-06	Rod Asm., Lever	34	532 13 71-67	Rod, Adj Lift
2	532 18 00-45	Shaft Asm., Lift Vgt	35	532 13 80-57	Knob, Inf 3/8-16 Unc
3	532 15 91-89	Lever Asm., Lift Rh	38	532 15 50-97	Pointer Height Indicator
4	812 00 00-22	E-Ring Truarc #5133-87	39	532 12 39-35	Plug, Hole Blk. 1.485/1.515 Dia.
5	819 29 20-16	Washer 29/32 x 1-1/4 x 16 Ga.	40	817 06 05-16	Screw 5/16-18 x 1
6	871 11 06-24	Bolt, Fin Hex 3/8-16 x 1-1/2	41	532 17 59-94	Nut, Lift Link 7/16-20
7	532 12 56-31	Grip, Handle	42	819 11 24-10	Washer 11/32 x 1-1/2 x 10 Ga.
8	532 12 45-26	Button, Plunger	43	532 12 39-34	Scale, Indicator Height
9	532 12 23-64	Plunger, Lever Lift	70	532 14 52-12	Nut Hex Flange Lock
10	532 18 38-94	Spring	72	532 11 04-52	Nut Push Phos & Oil
11	532 17 53-75	Link Lift	73	873 35 06-00	Nut, Hex Jam 3/8-16 Unc
12	532 16 35-52	Retainer, Spring	74	532 17 58-02	Arm Suspension Rear RH
23	532 12 46-70	Retainer, Spring	75	532 17 58-05	Plate, Asm, Susp, Front
24	873 35 08-00	Nut, Jam Hex 1/2-13 Unc	76	532 17 55-60	Pin Flange
26	873 80 08-00	Nut, Lock W/Wsh 1/2-13 Unc	77	532 17 62-05	Trunion Susp Arm
29	532 15 02-33	Trunion Infin Height	78	532 17 56-89	Trunion, Front, Susp
30	532 11 08-07	Nut, Special	79	532 17 53-78	Arm, Suspension LH
31	819 13 10-16	Washer 13/32 x 5/8 x 16 Ga.			
32	532 13 71-50	Spring, Compression Inf Hgt			
33	876 02 03-08	Pin, Cotter 3/32 x 1/2			

NOTE: All component dimensions given in U.S. inches
1 inch = 25.4 mm

REPAIR PARTS

TRACTOR - MODEL NO. GTH2548XP (HAU25H48B), PRODUCT NO. 954 17 00-87

MOWER DECK

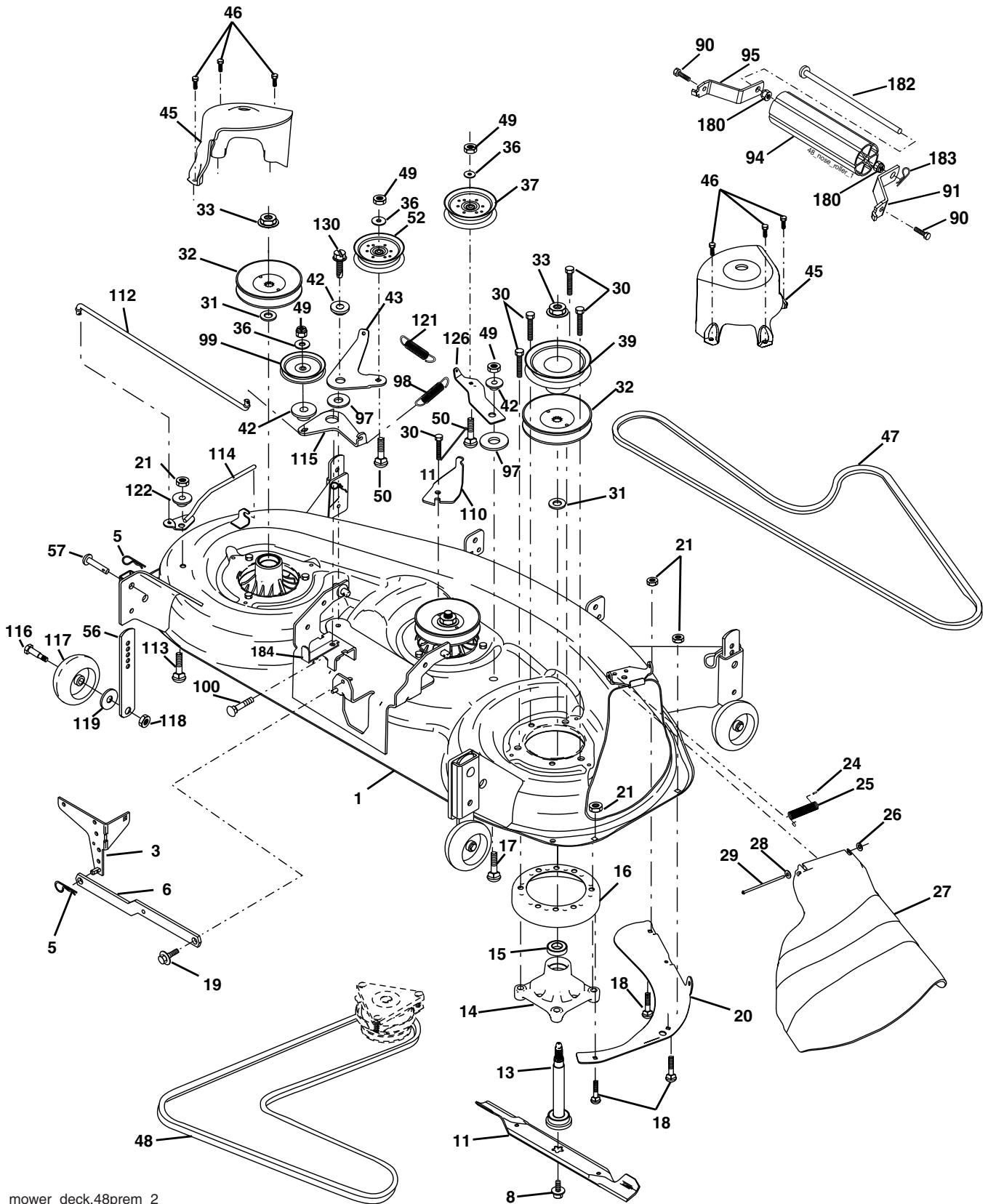

REPAIR PARTS

TRACTOR - MODEL NO. GTH2548XP (HAU25H48B), PRODUCT NO. 954 17 00-87

MOWER DECK

KEY NO.	PART NO.	DESCRIPTION	KEY NO.	PART NO.	DESCRIPTION
1	532 18 18-48	Deck Weldment Mower 48	56	532 15 59-86	Bar Pnt Adj.
3	532 17 89-15	Bracket Asm., Sway Bar	57	532 15 69-41	Pin Head Rivet
5	532 12 46-70	Retainer Spring	90	874 76 05-16	Bolt Hex HD 5/16-18 x 1
6	532 17 80-24	Bar Sway Deck	91	532 18 05-35	Bracket Asm N Roller RH
8	532 17 43-65	Bolt 7/16 Asm. Blade	93	819 17 14-16	Washer 17/32 x7/8 x 16 Ga
11	532 18 00-54	Blade	94	532 17 60-66	Roller Nose 48"
13	532 17 43-60	Shaft Asm. w/Lower Bearing	95	532 18 05-34	Bracket N Roller LH
14	532 17 43-58	Mandrel Asm.	97	532 17 85-15	Washer Hardened
15	532 11 04-85	Bearing, Ball, Mandrel	98	532 17 94-79	Spring Primary Drive
16	532 17 44-93	Stripper Mandrel Deck	99	532 18 40-85	Pulley Idler"V"
17	872 11 06-10	Bolt RDHD Sq Neck 3/8-16 x 1.25	100	872 11 06-16	Bolt RDHD Sqnk 3/8-16 UNC x 2
18	872 14 05-05	Bolt, Carriage 5/16-18 x 5/8	110	532 17 50-16	Arm Spring Secondary
19	532 13 28-27	Bolt, Hex Hd, Shoulder 5/16-18	112	532 17 43-87	Link Tension Relief Lever
20	532 17 43-78	Baffle, Vortex Mower	113	872 11 05-06	Bolt Carr. 5/16-18 x 3/4
21	873 68 05-00	Nut, Crownlock 5/16-18 UNC	114	532 17 43-84	Tension Asm. Relief Lever
24	532 10 53-04	Cap, Sleeve	115	532 17 46-09	Arm Spring Tension Relief
25	532 17 81-02	Spring, Torsion	116	532 18 42-19	Bolt, Shoulder
26	532 11 04-52	Nut, Push	117	532 13 39-57	Gauge Wheel
27	532 18 17-07	Deflector Shield	118	873 93 06-00	Nut, Centerlock 3/8-16 UNC
28	819 11 10-16	Washer 11/32 x 5/8 x 16 Ga.	119	819 12 14-14	Washer 3/8 x 7/8 x 14 Ga.
29	532 13 14-91	Rod, Hinge	121	532 17 43-71	Spring Secondary Drive
30	532 17 39-84	Screw, Thdroll Washer Head	122	532 17 46-06	Bushing Pivot Tension Relief
31	532 12 99-63	Washer, Spacer Mower Vented	126	532 17 43-72	Arm, Idler, Primary Deck
32	532 17 78-65	Pulley, Mandrel	130	817 00 06-16	Screw 3/8-16 x 1.0
33	532 17 83-42	Nut, Flg. Top Lock Cntr. 9/16	180	873 80 05-00	Nut Lock 5/16-18
36	819 13 13-16	Washer 13/32 x 13/16 x 16 Ga.	182	532 17 91-27	Rod Roller Nose Narrow
37	532 17 79-68	Pulley, Idler, Flat	183	532 16 35-52	Retainer Spring
39	532 17 43-75	Pulley, Idler, Driven	184	532 17 39-79	Keeper Belt Idler
42	532 12 20-52	Spacer, Retainer	--	532 17 43-56	Mandrel Asm. Service (Includes Key Nos. 13-15 and 33)
43	532 17 43-73	Arm, Idler Secondary	--	532 18 15-91	Replacement Mower, Complete (Std. Deck-Order separately nose roller components key nos. 90, 91, 94, 180, 182 and 183).
45	532 18 08-06	Cover, Mandrel Deck			
46	532 13 77-29	Screw, Thdroll. 1/4-20 x 5/8			
47	532 18 08-08	V-Belt, Mower, Secondary			
48	532 17 43-68	V-Belt, Mower, Primary			
49	873 68 06-00	Nut, Crownlock 3/8-16 UNC			
50	872 11 06-12	Bolt, Carr. 3/8-16 x 1-1/2 Gr. 5			
52	532 17 58-20	Pulley Idler Flat			

NOTE: All component dimensions given in U.S. inches
1 inch = 25.4 mm