

# LTH151

**Spare parts**

**Ersatzteile**

**Pièces détachées**

**Reserve onderdelen**

**Repuestos**

**Reservdelar**

# REPAIR PARTS

TRACTOR - MODEL NO. LTH151 (HELTH151C), PRODUCT NO. 954 17 02-02  
ELECTRICAL

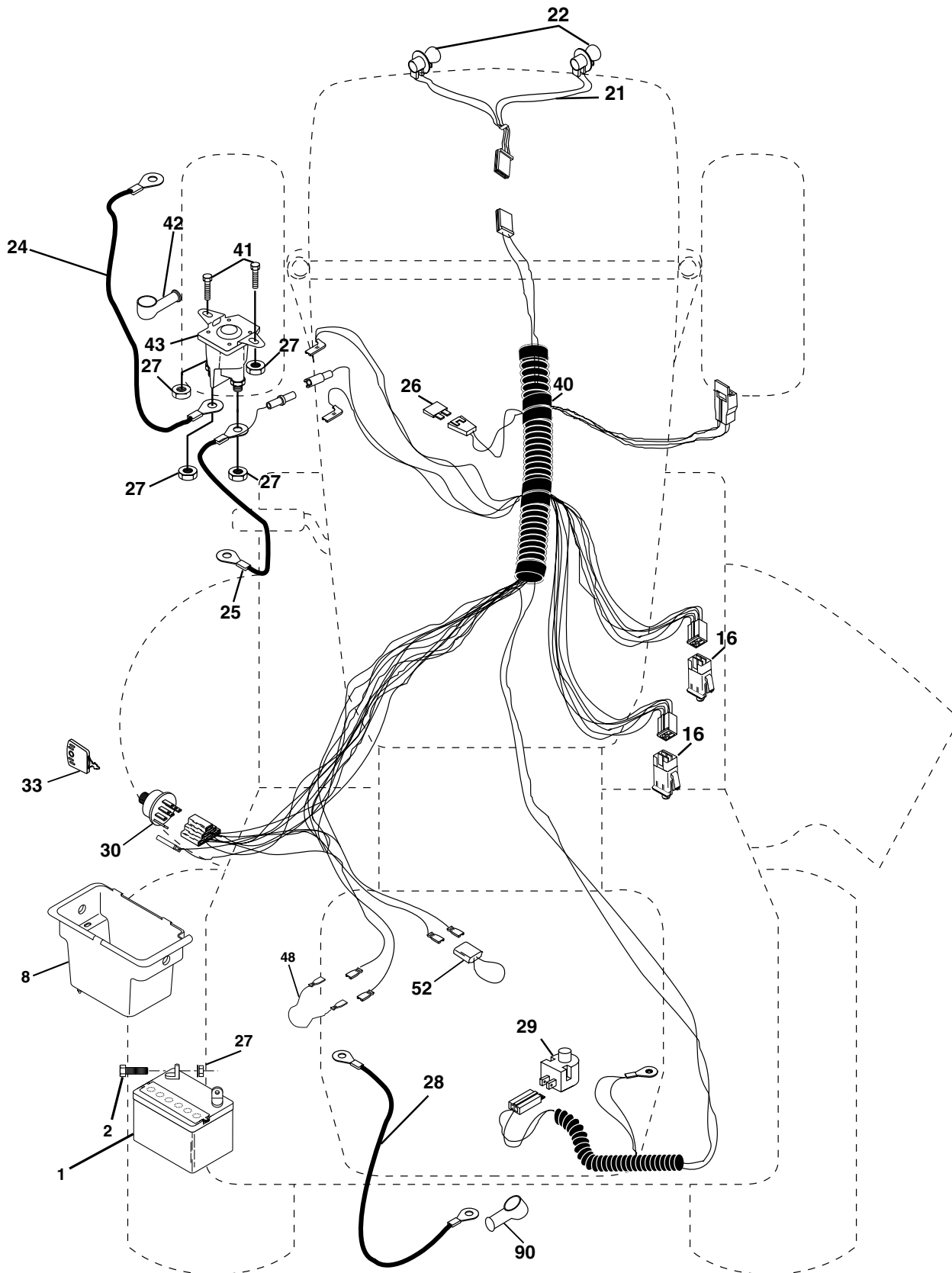

# REPAIR PARTS

TRACTOR - MODEL NO. LTH151 (HEALTH151C), PRODUCT NO. 954 17 02-02  
ELECTRICAL

KEY NO.	PART NO.	DESCRIPTION
1	532 14 49-27	Battery
2	874 76 04-12	Bolt Hex Hd 1/4-20 unc x 3/4
8	532 17 66-89	Case Battery Mech Hinge
16	532 17 61-38	Switch Interlock
21	532 17 56-88	Harness Asm Light W/4152j
22	532 00 41-52	Bulb Light #1156
24	532 12 47-80	Cable Battery 6 Ga. 11" red
25	532 14 61-47	Cable Battery 6 Ga. 44" red w/16 wire
26	532 17 51-58	Fuse 20 AMP
27	873 51 04-00	Nut Keps Hex 1/4-20 unc
28	532 12 47-73	Cable Ground 6 Ga. 12" black
29	532 12 13-05	Switch Plunger Nc Gray
30	532 17 55-66	Switch Ign
33	532 14 04-01	Key Ign Molded Generic
40	532 17 97-20	Harness Ign.
41	871 11 04-08	Bolt Blk Fin Hex 1/4 - 20 x 1/2
42	532 13 15-63	Cover Terminal Red
43	532 17 88-61	Solenoid
48	532 14 08-44	Adapter Ammeter Rectangular
52	532 14 19-40	Protection Wire Loop
90	532 18 04-49	Cover Terminal Battery

**NOTE:** All component dimensions given in U.S. inches.  
1 inch = 25.4 mm.

# REPAIR PARTS

TRACTOR - MODEL NO. LTH151 (HELTH151C), PRODUCT NO. 954 17 02-02  
CHASSIS AND ENCLOSURES

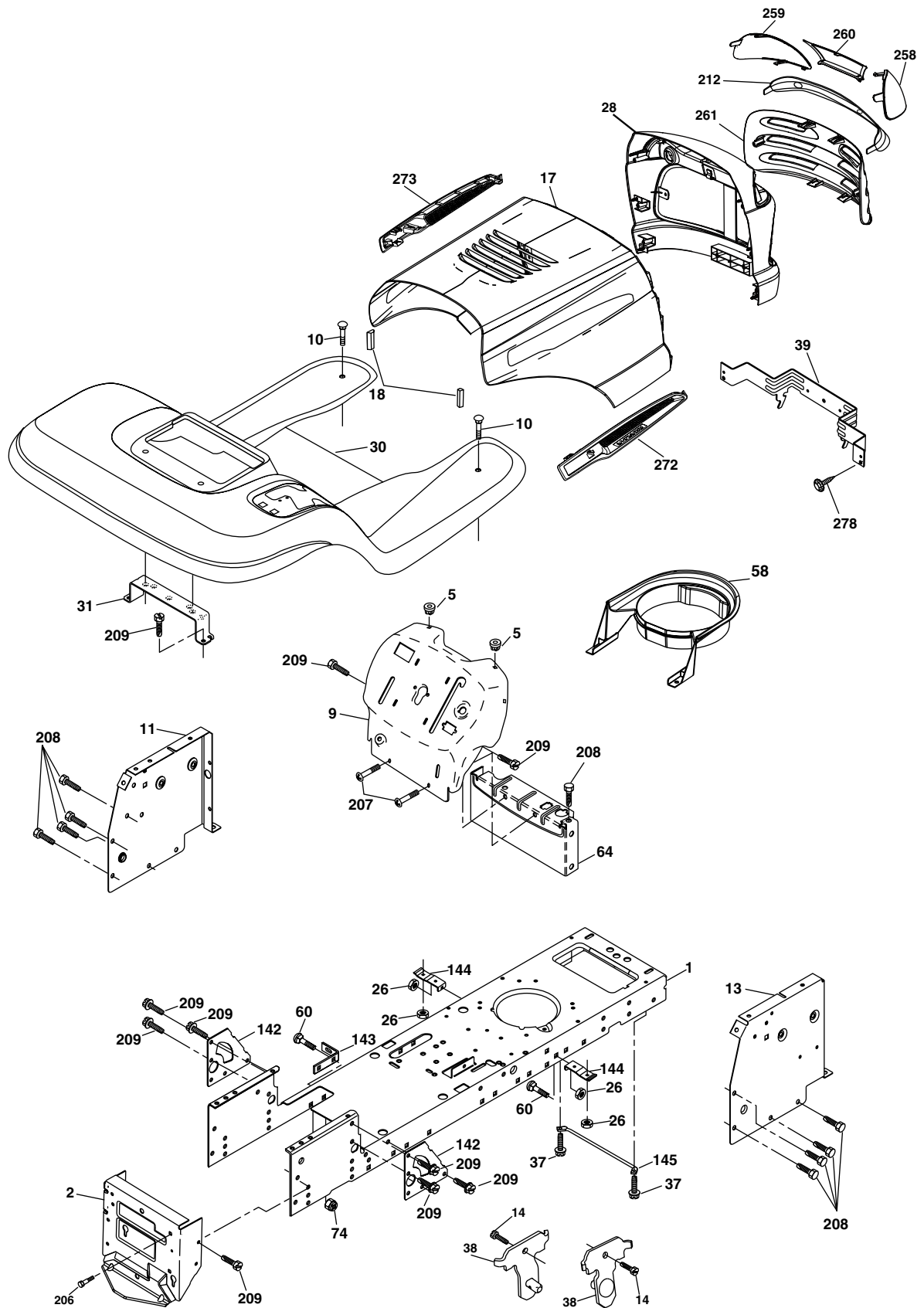

chassis-Laser -lt.stlt\_35

# REPAIR PARTS

## TRACTOR - MODEL NO. LTH151 (HEALTH151C), PRODUCT NO. 954 17 02-02 CHASSIS AND ENCLOSURES

KEY NO.	PART NO.	DESCRIPTION
1	532 17 46-19	Chassis Stamping
2	532 17 65-54	Drawbar
5	532 15 52-72	Bumper Hood/Dash
9	532 19 18-14	Dash P/L
10	872 14 06-08	Bolt Carriage 3/8-16 x 1
11	532 17 49-96	Panel Dash Lh
13	532 18 17-19	Panel Dash Rh
14	817 49 06-08	Screw thdrol 3/8-16 x 1/2
17	532 18 88-93	Hood
18	532 18 49-21	Bumper Hood
26	873 80 06-00	Nut Lock Hex W/Ins 3/8-16 unc
28	532 18 35-38	Grille/Len Asm
30	532 19 18-17	Fender Footrest STLT Pnt
31	532 13 99-76	Bracket Support Fender
37	817 49 05-08	Screw Thdrol 6/16-18 x 1/2 TYT
38	532 17 57-10	Bracket, Asm. Pivot, Mower Rear
39	532 17 47-14	Bracket Pivot Laser
58	532 18 71-54	Duct Air
60	872 14 06-06	Bolt Rdhd Sqnk 3/8-16 unc x 3/4
64	532 15 47-98	Dash Lower STLT
74	873 68 06-00	Nut Crownlock 3/8-16 unc
142	532 17 57-02	Plate Reinforcement STLT
143	532 18 66-89	Bracket Swaybar Chassis
144	532 17 55-82	Bracket Pnt Footrest STLT
145	532 15 65-24	Rod Pivot Chassis/Hood
206	532 17 01-65	Bolt Shoulder 5/16-18 TT
207	817 67 05-08	Screw Thdrol 5/16-18 x 1/2
208	817 67 06-08	Screw Thdrol 3/8-16 x 1/2
209	817 00 06-12	Screw Hex Wsh Thdrol 3/8-16- x 3/4
212	532 18 35-48	Insert Lens Reflect
258	532 18 52-13	Lens RH
259	532 18 52-14	Lens LH
260	532 18 52-16	Cover Lens
261	532 18 52-12	Insert Grille
272	532 18 88-95	Vent Hood RH
273	532 18 88-96	Vent Hood LH
278	<b>532 19 16-11</b>	Screw 10 x 3/4 Single Lead-Hex
--	532 00 54-79	Plug
--	532 18 78-01	Dome Plug Plastic (choke hole)

**NOTE:** All component dimensions given in U.S. inches.  
1 inch = 25.4 mm.

# REPAIR PARTS

TRACTOR - MODEL NO. LTH151 (HELTH151C), PRODUCT NO. 954 17 02-02  
DRIVE

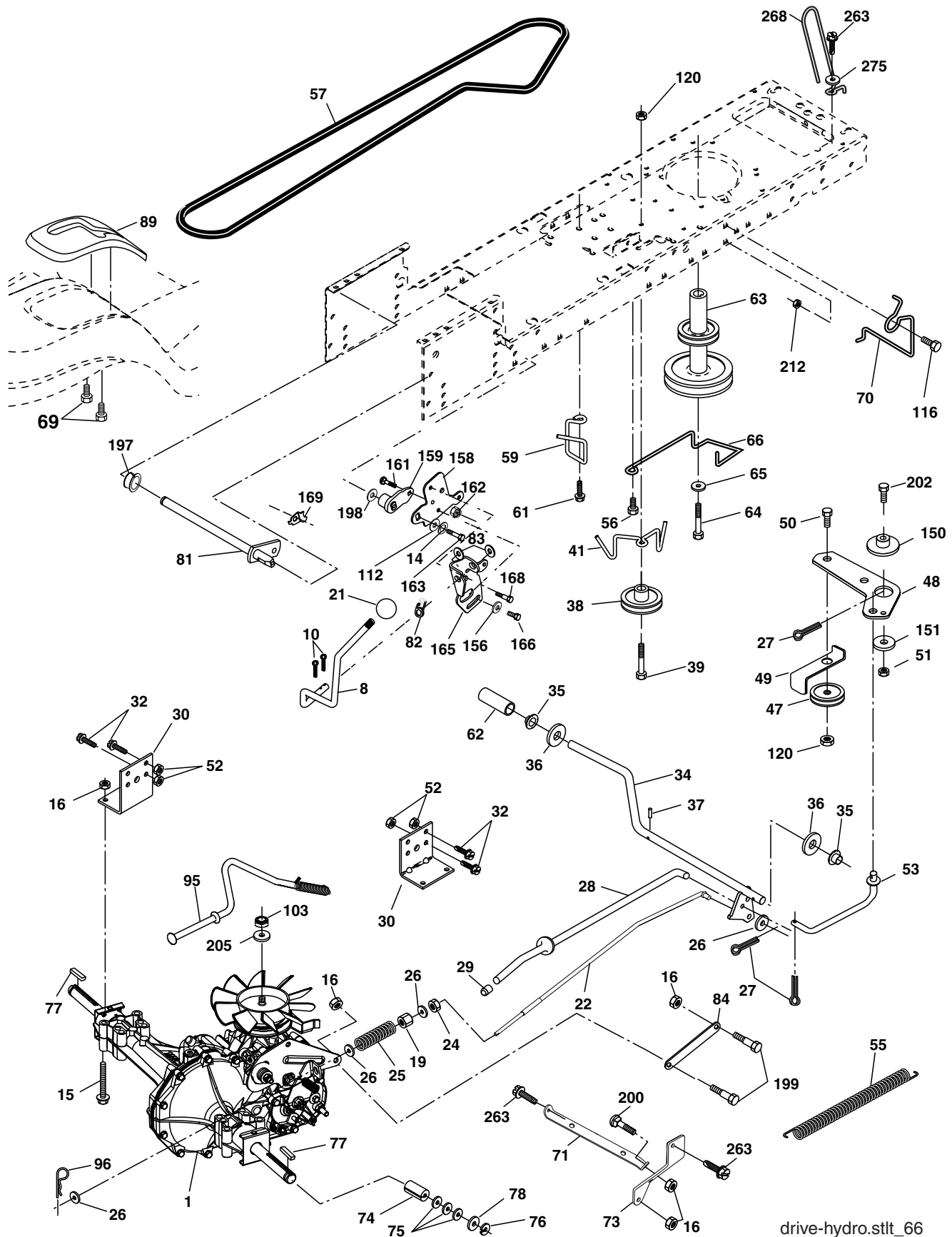

drive-hydro.stlt\_66

# REPAIR PARTS

## TRACTOR - MODEL NO. LTH151 (HELTH151C), PRODUCT NO. 954 17 02-02 DRIVE

KEY NO.	PART NO.	DESCRIPTION	KEY NO.	PART NO.	DESCRIPTION
1	-----	Transaxle Hydro Gr 322-0510 (Order parts from transaxle manufacturer)	70	532 18 02-18	Guide Belt Mower Drive RH
8	532 16 58-66	Rod Shift Fender STLT	71	532 16 91-83	Strap Torque Lh Hydro
10	876 02 04-16	Pin Cotter 1/8 x 1 CAD	73	532 16 91-82	Strap Torque Rh Hydro
14	810 04 04-00	Washer Lock Hvy Helical 1/4	74	532 13 70-57	Spacer, Axle
15	874 49 05-44	Bolt Hex Flg Hd 5/16-18 x Gr. 5	75	532 12 17-49	Washer 25/32 x 1-1/4 x 16 Ga.
16	873 80 05-00	Nut Lock Hex W/Ins. 5/16-18 unc P	76	812 00 00-01	E-Ring
19	873 80 06-00	Nut Lock Hex W/Wsh 3/8-16 unc	77	532 12 35-83	Key, Square
21	532 12 12-74	Knob	78	532 12 17-48	Washer 25/32 x 1-5/8 x 16 Ga.
22	532 16 94-98	Rod, Brake Hydro	81	532 16 55-96	Shaft Asm. Cross Hydro
24	873 35 06-00	Nut	82	532 16 57-11	Spring Torsion T/A
25	532 10 68-88	Spring, Brake Rod	83	819 17 12-16	Washer 17/32 x 3/4 x 16 Ga.
26	819 13 13-16	Washer	84	532 16 98-43	Link Transaxle
27	876 02 04-12	Pin Cotter 1/8 x 3/4 CAD.	89	532 19 18-16	Console, Shift
28	532 17 57-65	Rod, Parking Brake	95	532 17 02-01	Control Asm Bypass Hydro
29	532 07 16-73	Cap, Parking Brake	96	532 12 47-88	Retainer Spring 1" Zinc/Cad
30	532 17 49-73	Bracket, Transaxle	103	873 94 08-00	Nut Hex Jam Toplock 1/2-20 unf
32	874 76 05-12	Bolt Hex Hd 5/16-18 unc x 3/4	112	819 09 12-10	Washer 9/32 x 3/4 x 10 Ga.
34	532 17 55-78	Shaft, Foot Pedal, Nibbed	116	872 14 06-08	Bolt Rdhd 3/8-16 x 1
35	532 12 01-83	Bearing, Nylon	120	873 90 06-00	Nut Lock Flg 3/8-16
36	819 21 16-16	Washer	150	532 17 54-56	Spacer Retainer
37	532 12 49-63	Pin, Roll	151	819 13 32-10	Washer 13/32 x 2 x 10 Ga.
38	532 17 91-14	Pulley, Composite, Flat	156	532 16 60-02	Washer Srrtd 5/16 ID x 1.0 x .125 Tk
39	872 11 06-22	Bolt Rdhd 3/8-16 unc x 2-3/4 Gr. 5	158	532 16 55-89	Bracket Shift Mount
41	532 17 55-56	Keeper, Belt Idler	159	532 18 39-00	Hub Shift
47	532 12 77-83	Pulley, Idler, V-Groove	161	872 14 04-06	Bolt Rdhd Sqnk 1/4-20 x 3/4 Gr. 5
48	532 15 44-07	Bellcrank Clutch Grnd Drv Stl	162	873 68 04-00	Nut Crownlock 1/4-20 unc
49	532 12 32-05	Retainer, Belt	163	874 78 04-16	Bolt Hex Fin 1/4-20 unc x 1 Gr. 5
50	872 11 06-12	Bolt 3/8-16 x 1-1/2 Gr. 5	165	532 16 56-23	Bracket Pivot Lever
51	873 68 06-00	Nut Crownlock 3/8-16	166	817 49 05-10	Screw 5/16-18 x 5/8
52	873 68 05-00	Nut Crownlock 5/16-18	168	532 16 54-92	Bolt Shoulder 5/16-18 x .561 TT
53	532 10 57-10	Link, Clutch	169	532 16 55-80	Plate Fastening Cross Shf. STLT/ CRD
55	532 10 57-09	Spring, Return, Clutch	197	532 16 96-13	Nyliner Snap-In 5/8" ID
56	817 06 06-20	Screw 3/8-16 x 1	198	532 16 95-93	Washer Nyl 7/8 ID x .105 HYD CRD
57	532 14 02-94	V-Belt, Ground Drive	199	532 16 96-12	Bolt Shoulder 5/16-18 unc
59	532 16 96-91	Keeper, Center Span	200	872 14 05-08	Bolt Rdhd Sqnk 5/16-18 unc x 1
61	817 12 06-14	Screw 3/8-16 x 3/4	202	872 11 06-14	Bolt Carr 3/8-16 x 1-3/4 Gr. 5
62	532 12 48-72	Cover, Pedal	205	819 17 16-16	Washer 17/32 x 1 x 16 Ga.
63	532 18 02-19	Pulley, Eng	212	532 14 52-12	Nut Hex Flange Lock
64	532 17 39-37	Bolt Hex 7/16-20 x 4 Ga. 5	263	817 00 06-12	Screw 3/8-16 x 3/4
65	810 04 07-00	Washer	268	532 18 24-02	Guard Muffler RH
66	532 15 47-78	Keeper Belt Engine	275	819 13 16-14	Washer 13/32 x 1 x 14 Ga.
69	532 14 24-32	Screw			

**NOTE:** All component dimensions given in U.S. inches.  
1 inch = 25.4 mm.

# REPAIR PARTS

TRACTOR - MODEL NO. LTH151 (HELTH151C), PRODUCT NO. 954 17 02-02  
STEERING ASSEMBLY

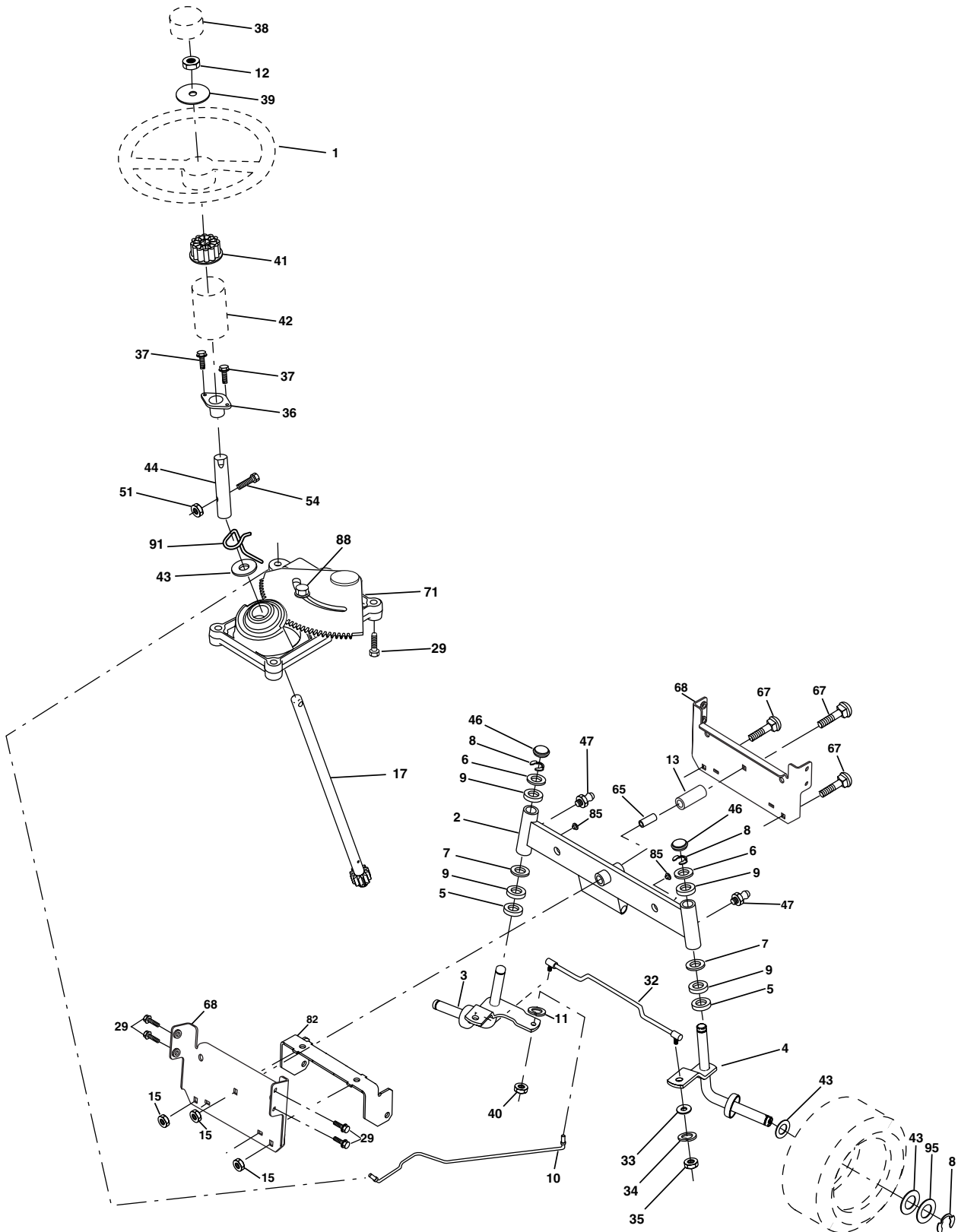

steering\_pl.it\_38



# REPAIR PARTS

## TRACTOR - MODEL NO. LTH151 (HEALTH151C), PRODUCT NO. 954 17 02-02 STEERING ASSEMBLY

KEY NO.	PART NO.	DESCRIPTION
1	532 16 66-27	Wheel Steering
2	532 17 51-31	Axle Asm STMP Dropped STL
3	532 16 98-40	Spindle Asm LH
4	532 16 98-39	Spindle Asm RH
5	532 12 49-31	Bearing Race Thrust Harden
6	532 12 17-48	Washer 25/32 x 1-5/8 x 16 Ga.
7	819 27 20-16	Washer 27/32 x 1-1/4 x 16 Ga.
8	812 00 00-29	Ring Klip #t5304-75
9	532 12 49-37	Bearing Col Strg Blk
10	532 17 51-21	Link Drag
11	810 04 06-00	Washer Lock Hvy Hlcl Spr 3/8
12	873 94 08-00	Nut Hex Jam Toplock 1/2-20
13	532 13 65-18	Spacer Brg Axle Front
15	532 14 52-12	Nut Hex Flange Lock
17	532 18 06-41	Shaft Asm Strg
29	817 00 06-12	Screw 3/8-16 x 3/4
32	532 17 18-88	Rod Tie
33	819 11 12-16	Washer 11/32 x 3/4 x 16 Ga.
34	810 04 05-00	Washer Lock 5/16
35	873 54 05-00	Crownlock Nut 5/16-24 unf
36	532 15 50-99	Bushing Strg
37	532 15 29-27	Screw
38	532 16 66-26	Insert Cap Strg Wh
39	819 18 24-11	Washer 9/16 x 1-1/2 12 Ga.
40	873 54 06-00	Nut Crownlock 3/8-24
41	532 15 99-45	Adaptor Wheel Strg
42	532 16 96-34	Boot Steering Shaft
43	532 12 17-49	Washer 25/32 x 1 1/4 x 16 Ga.
44	532 18 06-40	Extension Steering Shaft LR/LT
46	532 12 12-32	Cap Spindle Fr Top Blk
47	532 18 32-26	Fitting Grease
51	873 54 04-00	Nut 1/4-28
54	871 13 04-20	Bolt Hex 1/4-28 x 1-1/4
65	532 16 03-67	Spacer Brace Axle
67	872 11 06-18	Bolt, Rdhd Sqnk 3/8-16 x 2-1/4
68	532 16 98-27	Axle, Brace
71	532 17 51-46	Steering Asm.
82	532 16 98-35	Bracket Susp Chassis Front
88	532 17 51-18	Bolt Shoulder 7/16-20
91	532 17 55-53	Clip Steering
95	532 18 89-67	Washer Hardened

**NOTE:** All component dimensions given in U.S. inches.  
1 inch = 25.4 mm.

# REPAIR PARTS

TRACTOR - MODEL NO. LTH151 (HELTH151C), PRODUCT NO. 954 17 02-02  
ENGINE

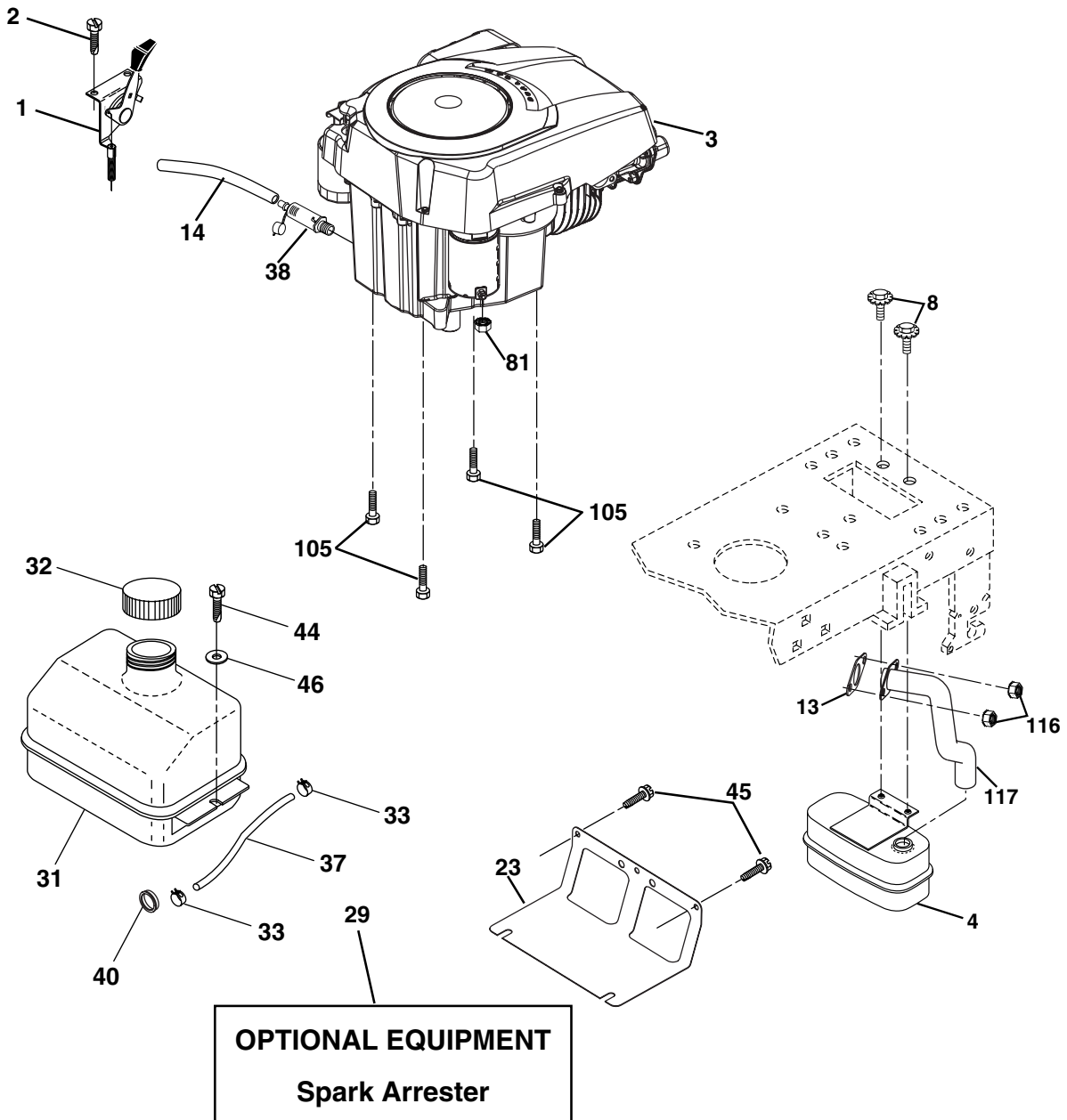

engine-kohler\_43

KEY NO.	PART NO.	DESCRIPTION	KEY NO.	PART NO.	DESCRIPTION
1	532 17 08-05	Control Throttle/Choke	33	532 12 34-87	Clamp Hose Black
2	817 72 04-08	Screw Hex Thd Cut 1/4-20 x 5/8 T	37	532 13 70-40	Line Fuel 20"
3	-----	Engine Kohler Model # <del>SV350</del> SV530 (Order Parts From Engine Manufacturer)	38	532 18 16-54	Plug Drain Oil Easy
4	532 18 86-55	Muffler	40	532 12 40-28	Bushing Snap Nyl Blk Fuel Line
8	532 17 18-77	Bolt 5/16-18 x 3/4	44	817 67 04-12	Screw Hexwsh Thdrol 1/4-20 x 3/4
13	532 18 59-09	Gasket Engine	45	817 00 06-12	Screw Hex Wsh Thdrol 3/8-16 x 3/4
14	532 14 84-56	Tube Drain Oil Easy	46	819 09 14-16	Washer 9/32 x 7/8 X 16 Ga
23	532 16 98-37	Shield Brn/Dbr Guard	81	873 51 04-00	Nut 1/4-20
29	532 13 71-80	Kit Spark Arrester (Flat Scrn)	105	817 12 06-16	Screw 3/8-16 x 1
31	532 18 49-00	Tank Fuel Front	116	532 18 43-62	Nut Hex Flange Toplock M8-1.25
32	532 14 05-27	Cap Asm Fuel W/sym Vented	117	532 18 86-54	Tube Exhaust

**NOTE:** All component dimensions given in U.S. inches.  
1 inch = 25.4 mm.

# REPAIR PARTS

## TRACTOR - MODEL NO. LTH151 (HELTH151C), PRODUCT NO. 954 17 02-02 SEAT ASSEMBLY

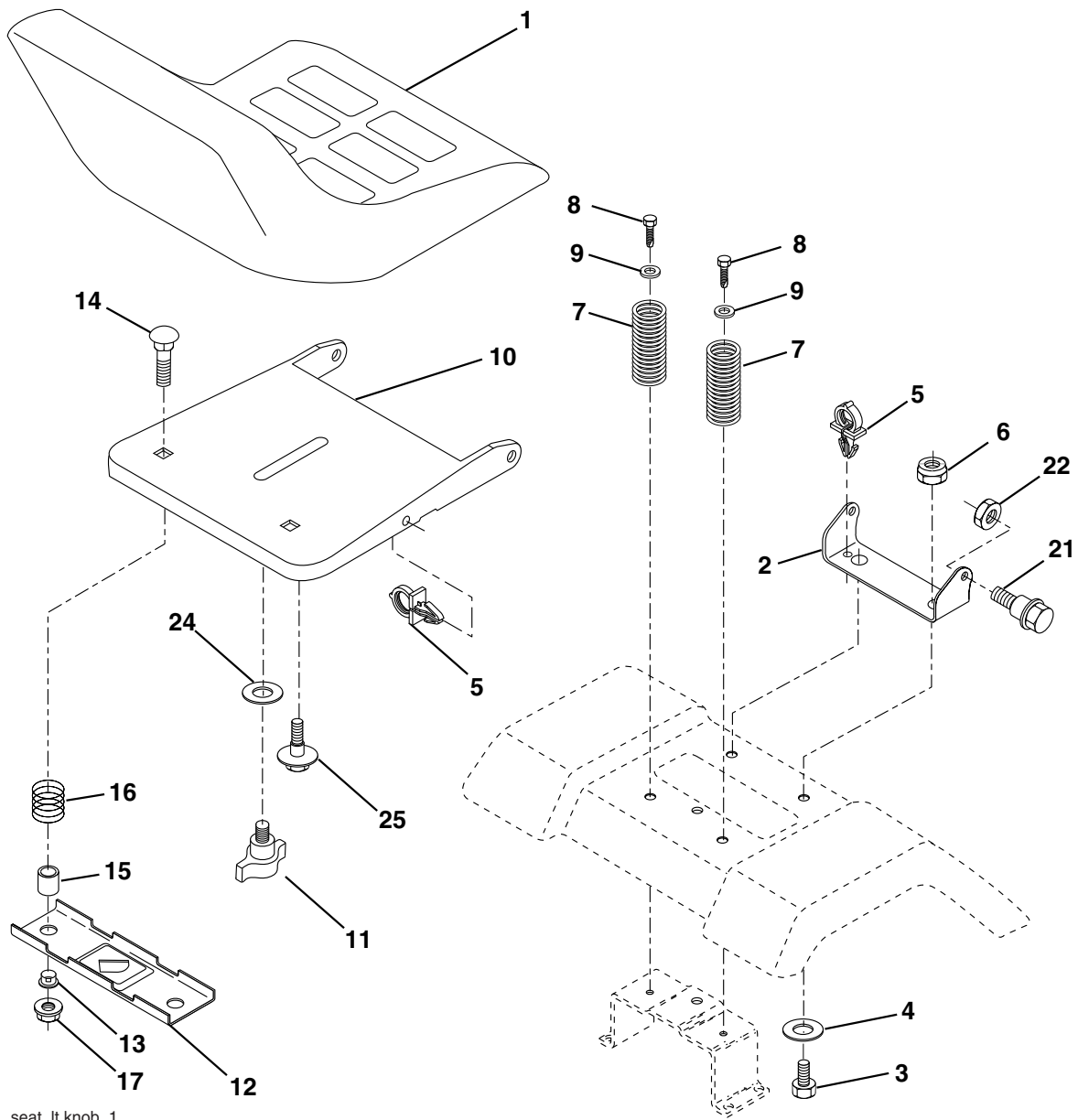

seat\_lt.knob\_1

KEY NO.	PART NO.	DESCRIPTION
1	532 18 49-92	Seat
2	532 14 05-51	Bracket Pivot Seat 8 720
3	871 11 06-16	Bolt Fin Hex 3/8-16 unc x 1
4	819 13 16-10	Washer 13/32 x 1 x 10 Ga.
5	532 14 50-06	Clip Push-In
6	873 80 06-00	Nut Hex w/Ins. 3/8-16 unc
7	532 12 41-81	Spring Seat Cprsn 2 250 Blk Zi
8	817 00 06-16	Screw 3/8-16 x 1-1/2
9	819 13 16-14	Washer 13/32 x 1 x 14 Ga.
10	532 18 24-93	Pan Seat
11	532 16 63-69	Knob Seat
12	532 12 12-46	Bracket Mounting Switch

KEY NO.	PART NO.	DESCRIPTION
13	532 12 12-48	Bushing Snap Blk Nyl 50 Id
14	872 05 04-12	Bolt Rdhd Sqnk 1/4-20 x 1-1/2
15	532 13 43-00	Spacer Split 28 x 96 Yel Zinc
16	532 12 12-50	Spring Cprsn 1 27 Blk Pnt
17	532 12 39-76	Nut Lock 1/4 Lge Flg Gr. 5 Zinc
21	532 17 18-52	Bolt Shoulder 5/16-18 unc
22	873 80 05-00	Nut Hex Lock W/Ins 5/16-18
24	819 17 19-12	Washer 17/32 x 1-3/16 x 12 Ga.
25	532 12 70-18	Bolt Shoulder 5/16-18 x 62

**NOTE:** All component dimensions given in U.S. inches.  
1 inch = 25.4 mm.

# REPAIR PARTS

TRACTOR - MODEL NO. LTH151 (HEALTH151C), PRODUCT NO. 954 17 02-02  
DECALS

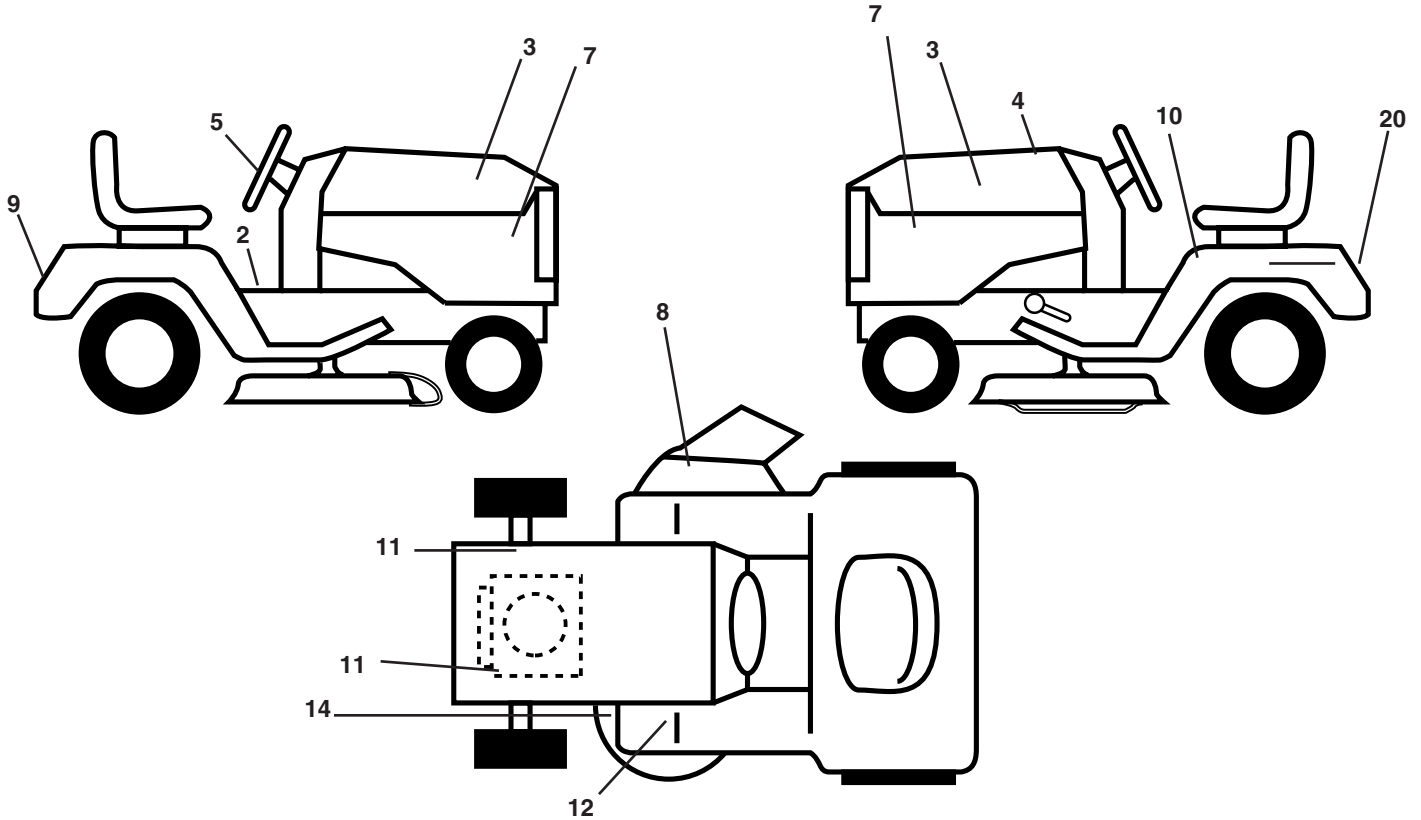

KEY NO.	PART NO.	DESCRIPTION
2	532 14 08-37	Decal Saddle Brake Parking
3	532 18 89-23	Decal Hood
4	532 18 91-51	Decal Replacement
5	532 18 89-25	Decal Steering
7	532 18 89-21	Decal Pnl Side
8	532 18 21-66	Decal Mower Cuttinger
9	532 18 89-31	Decal Fender
10	532 14 54-98	Decal Read Owner's Manual Syms.
11	532 15 97-36	Decal Chassis Hot Muffler

KEY NO.	PART NO.	DESCRIPTION
12	532 15 97-37	Decal Brake/ Clutch Symbol Lt
14	532 13 68-32	Decal V-Belt Schematic
20	532 14 50-05	Decal Bat Dan/Psn
--	532 18 82-52	Pad Footrest LH STLT
--	532 16 25-98	Decal Drawbar
--	532 18 82-53	Pad Footrest RH STLT
--	532 13 83-11	Decal Handle Lift Height Adjust
--	532 16 69-60	Decal Bypass
--	<b>532 19 28-99</b>	Manual Operator's (Euro.)
--	<b>532 19 29-00</b>	Manual Operator's (Scan.)

## WHEELS & TIRES

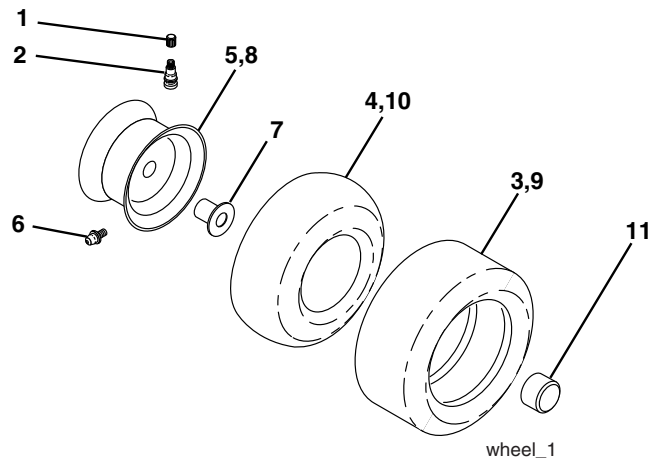

KEY NO.	PART NO.	DESCRIPTION
1	532 05 91-92	Cap Valve Tire
2	532 06 51-39	Stem Valve
3	532 10 62-22	Tire F Ts 15 x 6 0 - 6 Service
4	532 05 99-04	Tube Front (Service Item Only)
5	532 13 83-36	Rim Asm 6" front Silver Service
6	532 12 49-57	Fitting Grease (Front Wheel Only)
7	532 12 49-59	Bearing Flange (Front Wheel Only)
8	532 13 83-37	Rim Asm 8" rear Silver Service
9	532 10 62-68	Tire R Ts 18 x 9 5-8 C Service
10	532 12 49-26	Tube Rear (Service Item Only)
11	532 17 50-39	Cap Axle Blk 1 50 x 1 00
--	532 14 43-34	Sealant, Tire (10 oz. Tube)

**NOTE:** All component dimensions given in U.S. inches.  
1 inch = 25.4 mm.

# REPAIR PARTS

TRACTOR - MODEL NO. LTH151 (HELTH151C), PRODUCT NO. 954 17 02-02  
MOWER LIFT

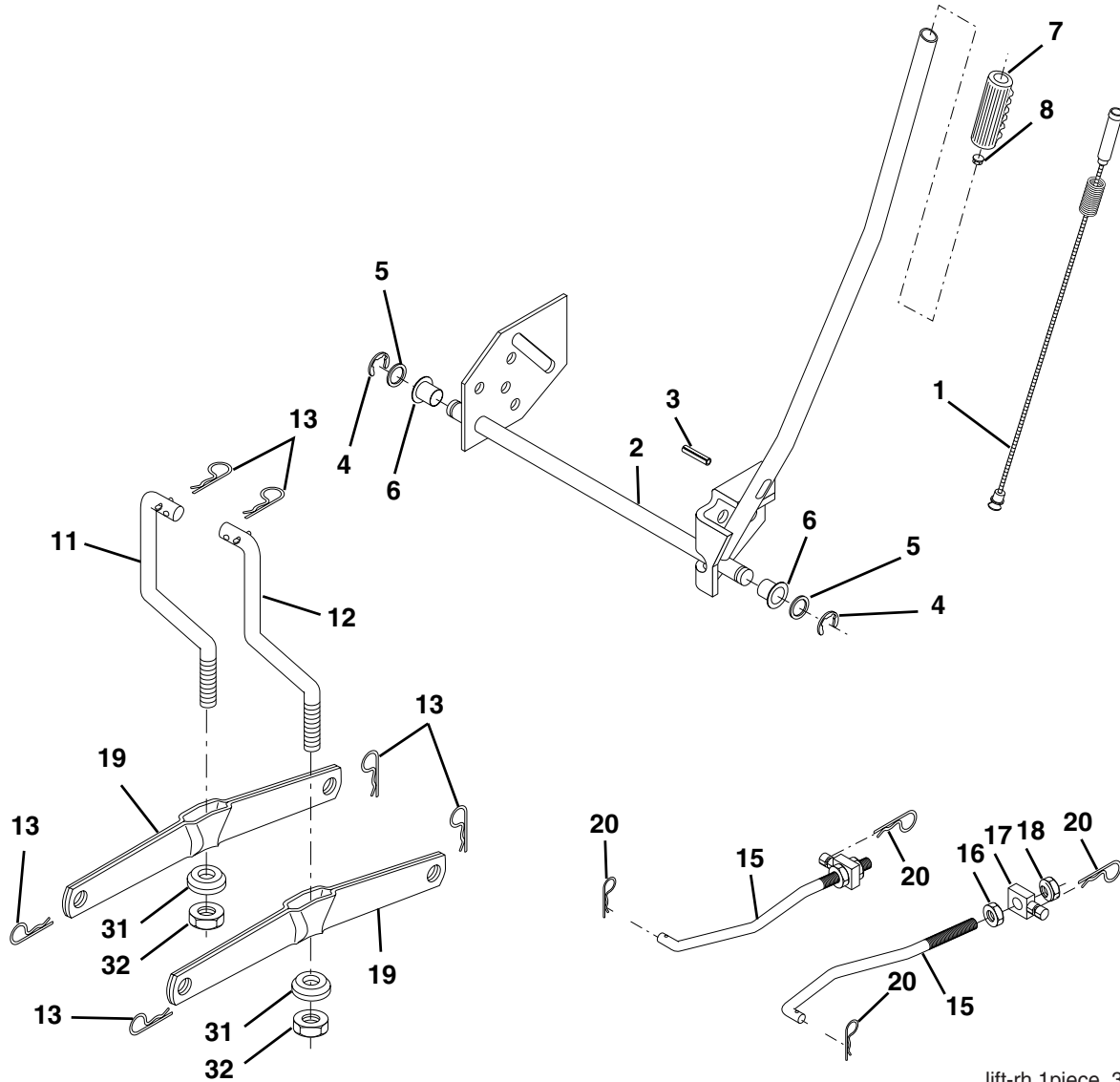

lift-rh.1piece\_3

KEY NO.	PART NO.	DESCRIPTION
1	532 15 94-60	Wire Asm Inner/Spring W/plunger
2	532 15 94-71	Shaft Asm Lift
3	532 10 57-67	Pin Groove
4	812 00 00-02	E Ring #5133-62
5	819 21 16-21	Washer PLTD 21/32 x 1 x 21Ga.
6	532 12 01-83	Bearing Nylon Blk 629 Id
7	532 10 94-13	Grip Handle Bicycle
8	532 12 45-26	Button Plunger Black
11	532 13 98-65	Link Lift LH
12	532 13 98-66	Link Lift RH
13	532 12 46-70	Retainer Spring
15	532 17 32-88	Link Front
16	873 35 08-00	Nut Jam Hex 1/2-13 unc
17	532 17 56-89	Trunnion Blk Zinc
18	873 80 08-00	Nut Lock W/wsh 1/2-13 unc
19	532 13 98-68	Arm Suspension Rear
20	532 16 35-52	Spring, Retainer
31	532 16 98-65	Bearing Pvt. Lift
32	873 54 06-00	Nut Crownlock 3/8-24

**NOTE:** All component dimensions given in U.S. inches.  
1 inch = 25.4 mm.



# REPAIR PARTS

TRACTOR - MODEL NO. LTH151 (HEALTH151C), PRODUCT NO. 954 17 02-02  
MOWER DECK

KEY NO.	PART NO.	DESCRIPTION	KEY NO.	PART NO.	DESCRIPTION
1	532 17 45-95	Mower Deck Assembly	55	532 13 38-40	Idler Arm Assembly
2	872 14 05-06	Bolt	56	532 16 57-23	Spacer, Retainer
3	532 13 80-17	Bracket Assembly,Sway Bar	67	532 10 69-32	Knob RD 3/8-16 Plstc Thd
4	532 17 56-54	Bracket Sway Bar	68	532 18 02-13	Belt
5	532 12 46-70	Retainer Spring	89	819 13 13-11	Washer 13/32 x 13/16 x 11 Ga.
6	532 17 80-24	Bar Sway Deck	92	873 80 06-00	Nut Lock Hex w/Ins 3/8-16 unc
7	532 14 06-08	Keeper Belt	107	532 13 35-02	Spacer, Retainer
8	532 85 08-57	Bolt, Hex 3/8-24 x 1.25 Gr. 8	108	532 13 35-03	Stiffener, Idler Arm
9	810 03 06-00	Washer, Lock Hvy Hlcl 3/8	113	817 49 05-08	Screw Thdrol 5/16-18 x 1/2
10	532 14 02-96	Washer, Hardened	122	532 17 45-05	Rod, Brake, LH
11	532 13 84-96	Blade, Mower	123	532 17 45-04	Rod, Brake, RH
13	532 13 76-45	Shaft Assembly, Mandrel, Vented	129	819 13 13-12	Washer 13/32 x 13/16 x 12 Ga.
14	532 12 87-74	Housing, Mandrel, Vented	130	874 78 06-16	Bolt Fin Hex 3/8-16 unc x 1 Gr. 5
15	532 11 04-85	Bearing, Ball, Mandrel	131	872 14 06-08	Bolt Rdhd Sqnk 3/8-16 unfc x 1
16	532 17 44-93	Stripper, Vented Mower Deck	146	532 16 58-91	Bolt Carriage Idler
19	532 13 28-27	Bolt, Shoulder	148	532 16 90-22	Spring Return Idler
21	873 68 05-00	Nut Crownlock 5/16-18	149	532 16 58-98	Retainer Spring Yellow Zinc
23	532 13 66-31	Bracket, Mower Deflector	150	819 09 12-10	Washer 9/32 x 3/4 x 10 Ga.
24	532 10 53-04	Cap, Sleeve	152	532 17 60-79	Cable Clutch
25	532 12 37-13	Spring, Torsion, Deflector	158	817 72 04-08	Screw Hex Thd Cut 1/4-20 x 5/8
26	532 11 04-52	Nut, Push	164	532 17 49-76	Bracket Asm Idler Support
27	532 17 61-62	Shield, Deflector	168	532 17 23-77	Bracket Deck Cable
28	819 11 10-16	Washer 11/32 x 5/8 x 16 Ga.	169	532 17 49-77	Bracket Asm Suspension
29	532 12 19-80	Rod, Hinge	170	532 17 23-59	Bracket Suspension RF
30	532 17 39-84	Screw Thdrol Washer Head	171	532 16 52-37	Bracket Support Susp. Frt
31	532 18 76-90	Washer, Spacer	172	532 17 23-55	Bracket Suspension LF
32	532 15 35-31	Pulley, Mandrel	--	532 13 07-94	Mandrel Assembly (Includes Housing Shaft and Shaft Hardware Only - Pulley Not Included)
33	532 17 83-42	Nut, Toplock, Flanged			
34	872 11 06-14	Bolt Rdhd 3/8-16 x 1-3/4	185	532 18 82-34	Head Asm Cable Clutch
36	532 13 14-94	Pulley, Idler, Flat	--	532 18 13-76	Replacement Mower, Complete
40	873 68 06-00	Nut Crownlock 3/8-16			
45	532 12 47-88	Retainer, Spring			
53	532 13 08-40	Brake Assembly			
54	532 17 85-15	Washer, Hardened			

**NOTE:** All component dimensions given in U.S. inches.  
1 inch = 25.4 mm.

