

Ride Mower

LTH18542 C

954571731



Repair Parts Manual

TRACTOR - - MODEL NO. LTH18542 (LTH18542C), PRODUCT NO. 954 57 17-31 SCHEMATIC

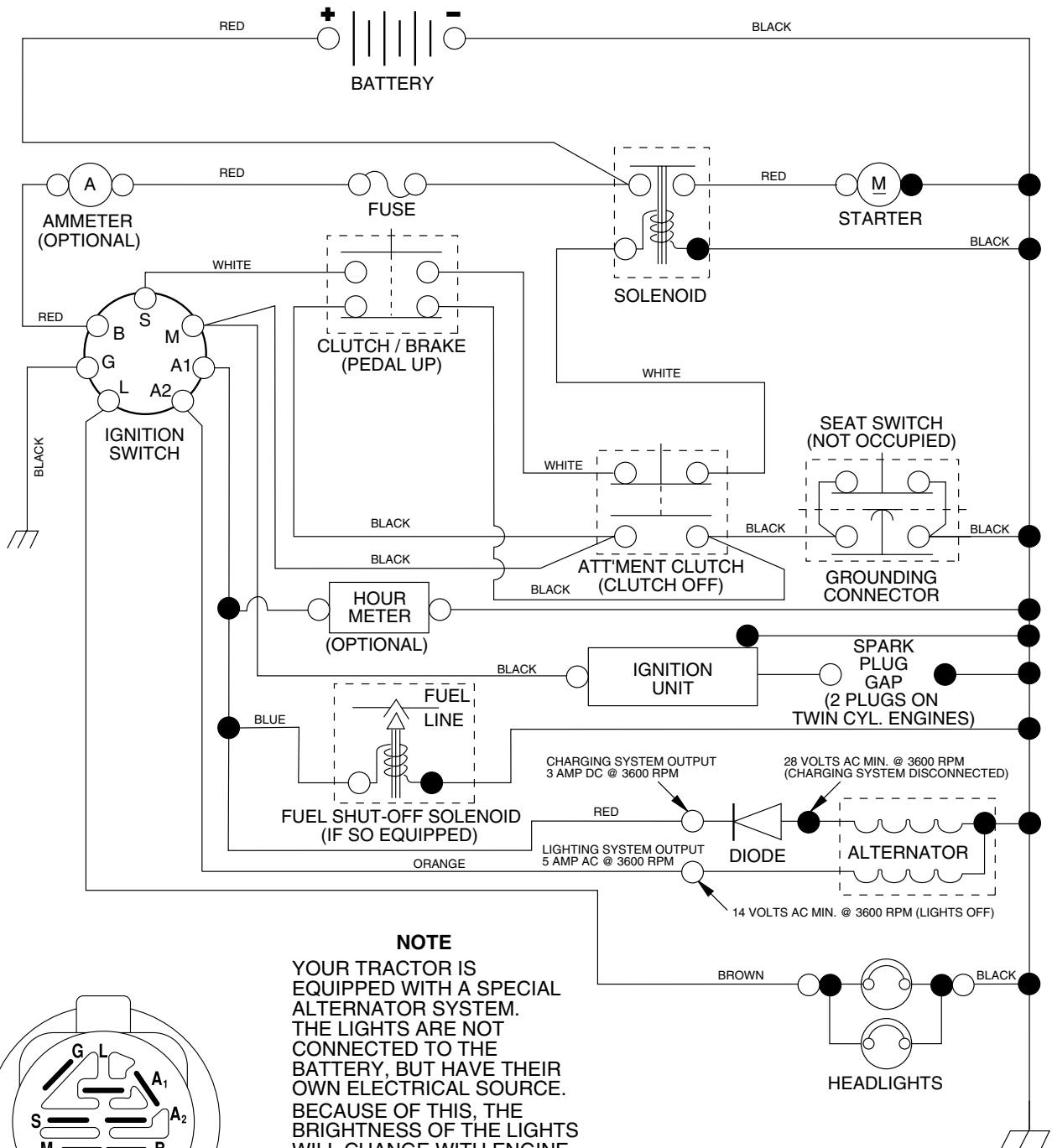

NOTE

YOUR TRACTOR IS EQUIPPED WITH A SPECIAL ALTERNATOR SYSTEM. THE LIGHTS ARE NOT CONNECTED TO THE BATTERY, BUT HAVE THEIR OWN ELECTRICAL SOURCE. BECAUSE OF THIS, THE BRIGHTNESS OF THE LIGHTS WILL CHANGE WITH ENGINE SPEED. AT IDLE THE LIGHTS WILL DIM. AS THE ENGINE IS SPEEDED UP, THE LIGHTS WILL BECOME THEIR BRIGHTEST.

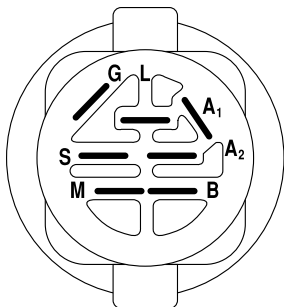

IGNITION SWITCH

POSITION	CIRCUIT	"MAKE"
OFF	M+G+A1	NONE
RUN/LIGHT	B+A1	A2+L
RUN	B+A1	NONE
START	B + S + A1	NONE

WIRING INSULATED CLIPS

NOTE: IF WIRING INSULATED CLIPS WERE REMOVED FOR SERVICING OF UNIT, THEY SHOULD BE REPLACED TO PROPERLY SECURE YOUR WIRING.

02363

NON-REMOVABLE CONNECTIONS

REMOVABLE CONNECTIONS

REPAIR PARTS

TRACTOR - - MODEL NO. LTH18542 (LTH18542C), PRODUCT NO. 954 57 17-31
ELECTRICAL

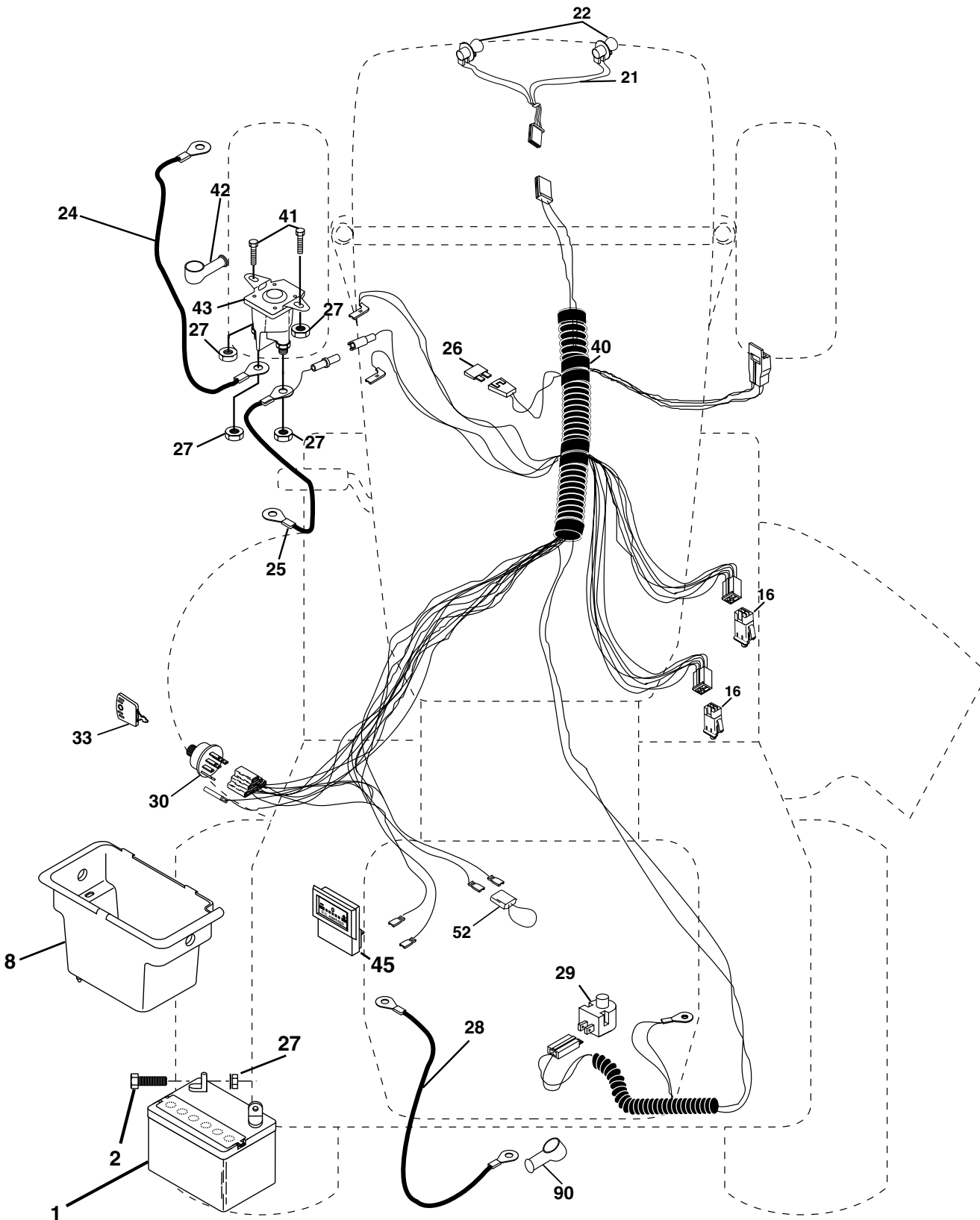

REPAIR PARTS

TRACTOR - - MODEL NO. LTH18542 (LTH18542C), PRODUCT NO. 954 57 17-31
ELECTRICAL

KEY NO.	PART NO.	DESCRIPTION
1	532 16 34-65	Battery
2	874 76 04-12	Bolt Hex Hd 1/4-20 unc x 3/4
8	532 17 66-89	Box Battery
16	532 17 61-37	Switch Interlock
21	532 17 56-88	Harness Asm Light W/4152j
22	532 00 41-52	Bulb Light #1156
24	532 12 47-80	Cable Battery 6 Ga. 11" red
25	532 14 61-47	Cable Battery 6 Ga. 44" red w/16 wire
26	532 17 51-58	Fuse
27	873 51 04-00	Nut Keps Hex 1/4-20 unc
28	532 12 47-73	Cable Ground 6 Ga. 12" black
29	532 12 13-05	Switch Plunger Olive
30	532 17 55-66	Switch Ign Delta
33	532 14 04-01	Key Ign Molded Generic
40	532 17 97-20	Harness Ign.
41	871 11 04-08	Bolt Blk Fin Hex 1/4 - 20 x 1/2
42	532 13 15-63	Cover Terminal Red
43	532 17 88-61	Solenoid
45	532 12 14-33	Ammeter Rectangular
52	532 14 19-40	Protection Wire Loop
90	532 18 04-49	Cover Terminal Battery

NOTE: All component dimensions given in U.S. inches.
1 inch = 25.4 mm.

REPAIR PARTS

TRACTOR - - MODEL NO. LTH18542 (LTH18542C), PRODUCT NO. 954 57 17-31
CHASSIS AND ENCLOSURES

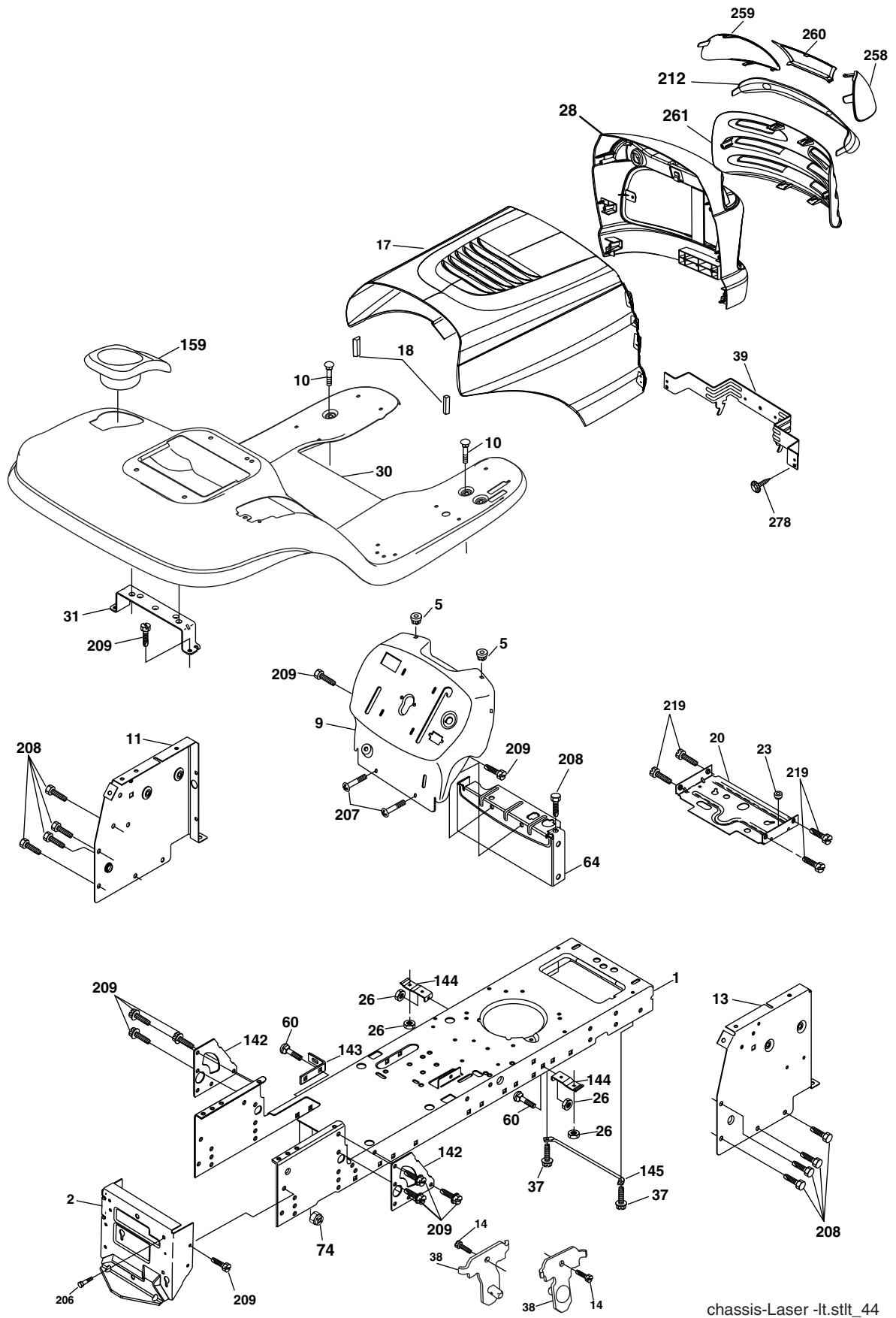

chassis-Laser -lt.stlt_44

REPAIR PARTS

TRACTOR - - MODEL NO. LTH18542 (LTH18542C), PRODUCT NO. 954 57 17-31 CHASSIS AND ENCLOSURES

KEY NO.	PART NO.	DESCRIPTION
1	532 17 46-19	Chassis Stamping
2	532 17 65-54	Drawbar, 12 Ga.
5	532 15 52-72	Bumper Hood/Dash
9	532 19 19-41	Dash Silscr
10	872 14 06-08	Bolt Carriage 3/8-16 x 1
11	532 17 49-96	Panel Dash Lh
13	532 18 17-19	Panel Dash Rh
14	817 49 06-08	Screw Thdrol 3/8-16 x 1/2
17	532 18 73-48	Hood
18	532 18 49-21	Bumper Hood
20	532 18 06-79	Plate Mounting Battery
23	532 12 40-28	Bushing Snap
26	873 80 06-00	Nut Lock Hex W/Ins 3/8-16 unc
28	532 18 52-92	Grille/Lens Asm (Includes Key Nos. 212, 258 and 261)
30	532 19 20-13	Fender Footrest
31	532 13 99-76	Bracket Fender
37	817 49 05-08	Screw Thdrol 6/16-18 x 1/2 TYT
38	532 17 57-10	Bracket Asm Pivot Mower Rear
39	532 17 47-14	Bracket Pivot
60	872 14 06-06	Bolt RdHd Sqnk 3/8-16 unc x 3/4
64	532 15 47-98	Dash Lower STLT
74	873 68 06-00	Nut Crownlock 3/8-16 unc
142	532 17 57-02	Plate Reinforcement STLT
143	532 18 66-89	Bracket Swaybar Chassis
144	532 17 55-82	Bracket Footrest
145	532 15 65-24	Rod Pivot Chassis/Hood
159	532 16 65-08	Cupholder
166	532 17 18-75	Screw HwHd Hi-Lo #13-16 x 3/4
206	532 17 01-65	Bolt Shoulder 5/16-18 TT
207	817 67 05-08	Screw Thdrol 5/16-18 x 1/2
208	817 67 06-08	Screw Thdrol 3/8-16 x 1/2 Ty-tt
209	817 00 06-12	Screw Hex Wsh Thdr. 3/8-16 x 3/4
212	532 18 35-48	Insert Lens Reflective
219	817 00 05-12	Screw 5/16-18 x 3/4
258	532 18 52-14	Lens Husq Laser LT Clear RH
259	532 18 52-13	Lens Husq Laser LT Clear LH
260	532 18 54-29	Cover Lens
261	532 18 54-33	Insert Grille
--	532 00 54-79	Plug Button
--	532 18 78-01	Plug, Domed Plastic

NOTE: All component dimensions given in U.S. inches
1 inch = 25.4 mm

REPAIR PARTS

TRACTOR - - MODEL NO. LTH18542 (LTH18542C), PRODUCT NO. 954 57 17-31
DRIVE

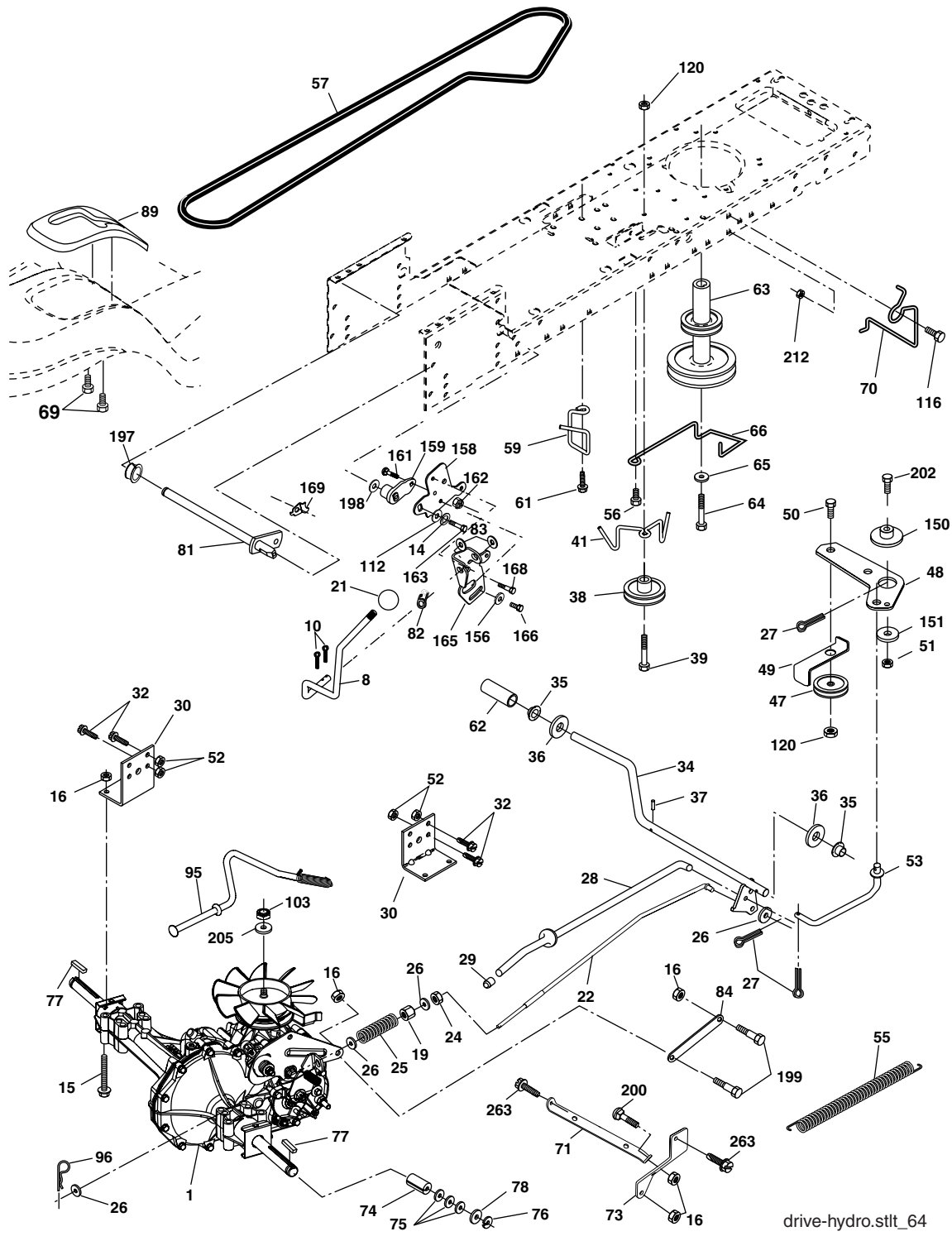

drive-hydro.stlt_64

REPAIR PARTS

**TRACTOR - - MODEL NO. LTH18542 (LTH18542C), PRODUCT NO. 954 57 17-31
DRIVE**

KEY NO.	PART NO.	DESCRIPTION	KEY NO.	PART NO.	DESCRIPTION
1	-----	Transaxle Hydro Gr Model 322-0510 (Order parts from transaxle mfg.)	70	532 13 46-83	Guide Belt Mower Drive RH
8	532 16 58-66	Rod Shift Fender	71	532 16 91-83	Strap Torque Lh Hydro
10	876 02 04-16	Pin Cotter 1/8 x 1 CAD	73	532 16 91-82	Strap Torque Rh Hydro
14	810 04 04-00	Washer Lock Hvy Helical 1/4	74	532 13 70-57	Spacer, Axle
15	874 49 05-44	Bolt Hex Flg Hd 5/16-18 x Gr. 5	75	532 12 17-49	Washer 25/32 x 1-1/4 x 16 Ga.
16	873 80 05-00	Nut Lock Hex W/Ins. 5/16-18 unc P	76	812 00 00-01	E-Ring
19	873 80 06-00	Nut Lock Hex W/Wsh 3/8-16 unc	77	532 12 35-83	Key, Square
21	532 14 08-45	Knob, Deluxe	78	532 12 17-48	Washer 25/32 x 1-5/8 x 16 Ga.
22	532 16 94-98	Rod, Brake Hydro	81	532 16 55-96	Shaft Asm. Cross Hydro
24	873 35 06-00	Nut	82	532 16 57-11	Spring Torsion T/A
25	532 10 68-88	Spring, Brake Rod	83	819 17 12-16	Washer 17/32 x 3/4 x 16 Ga.
26	819 13 13-16	Washer	84	532 16 98-43	Link Transaxle
27	876 02 04-12	Pin Cotter 1/8 x 3/4 CAD.	89	532 19 18-16	Console, Shift
28	532 17 57-65	Rod, Parking Brake	95	532 17 02-01	Control Asm Bypass Hydro
29	532 07 16-73	Cap, Parking Brake	96	532 12 47-88	Retainer Spring 1" Zinc/Cad
30	532 17 49-73	Bracket, Transaxle	103	873 94 08-00	Nut Hex Jam Toplock 1/2-20 unf
32	874 76 05-12	Bolt Hex Hd 5/16-18 unc x 3/4	112	819 09 12-10	Washer 9/32 x 3/4 x 10 Ga.
34	532 17 55-78	Shaft, Foot Pedal	116	872 14 06-08	Boulon 3/8-16 x 1
35	532 12 01-83	Bearing, Nylon	120	873 90 06-00	Nut Lock Flg 3/8-16
36	819 21 16-16	Washer	150	532 17 54-56	Spacer Retainer
37	532 12 49-63	Pin, Roll	151	819 13 32-10	Washer 13/32 x 2 x 10 Ga.
38	532 17 91-14	Pulley, Composite	156	532 16 60-02	Washer Srrtd 5/16 ID x 1.0 x .125 Tk
39	872 11 06-22	Bolt 3/8-16 x 2 3/4 Gr. 5	158	532 16 55-89	Bracket Shift Mount
41	532 17 55-56	Keeper, Belt Idler	159	532 18 39-00	Hub Tapered Flange Shift LT
47	532 12 77-83	Pulley, Idler, V-Groove	161	872 14 04-06	Bolt Rdhd Sqnk 1/4-20 x 3/4 Gr. 5
48	532 15 44-07	Bellcrank Clutch Grnd Drv Stl	162	873 68 04-00	Nut Crownlock 1/4-20 unc
49	532 12 32-05	Retainer, Belt	163	874 78 04-16	Bolt Hex Fin 1/4-20 unc x 1 Gr. 5
50	872 11 06-12	Bolt Carr Sh 3/8-16 x 1-1/2 Gr. 5	165	532 16 56-23	Bracket Pivot Lever
51	873 68 06-00	Nut	166	817 49 05-10	Screw 5/16-18 x 5/8 TT Yellow
52	873 68 05-00	Nut Crownlock 5/16-18	168	532 16 54-92	Bolt Shoulder 5/16-18 x .561 TT
53	532 10 57-10	Link, Clutch	169	532 16 55-80	Plate Fastening Cross Shf. STLT/ CRD
55	532 10 57-09	Spring, Return, Clutch	197	532 16 96-13	Nyliner Snap-In 5/8" ID
56	817 06 06-20	Screw 3/8-16 x 1-1/4	198	532 16 95-93	Washer Nyl. 7/8 ID x .105"
57	532 14 02-94	V-Belt, Ground Drive	199	532 16 96-12	Bolt Shoulder 5/16-18 unc
59	532 16 96-91	Keeper, Center Span	200	872 14 05-08	Bolt Rdhd Sq Neck 5/16-18 unc x 1
61	817 12 06-14	Screw 3/8-16 x .875	202	872 11 06-14	Bolt Carr Sh 3/8-16 x 1-3/4 Gr. 5
62	532 12 48-72	Cover, Pedal	205	819 17 16-16	Washer 17/32 x 1 x 16 Ga.
63	532 17 54-10	Pulley, Clutch Eng	212	532 14 52-12	Nut Hex Flg Lock
64	532 17 39-37	Bolt Hex 7/16-20 x 4 x Gr. 5-1.5 THR	263	817 00 06-12	Screw 3/8-16 x 3/4
65	810 04 07-00	Washer			
66	532 15 47-78	Keeper Belt Engine			
69	532 14 24-32	Screw			

NOTE: All component dimensions give in U.S. inches.
1 inch = 25.4 mm.

REPAIR PARTS

TRACTOR - - MODEL NO. LTH18542 (LTH18542C), PRODUCT NO. 954 57 17-31
STEERING ASSEMBLY

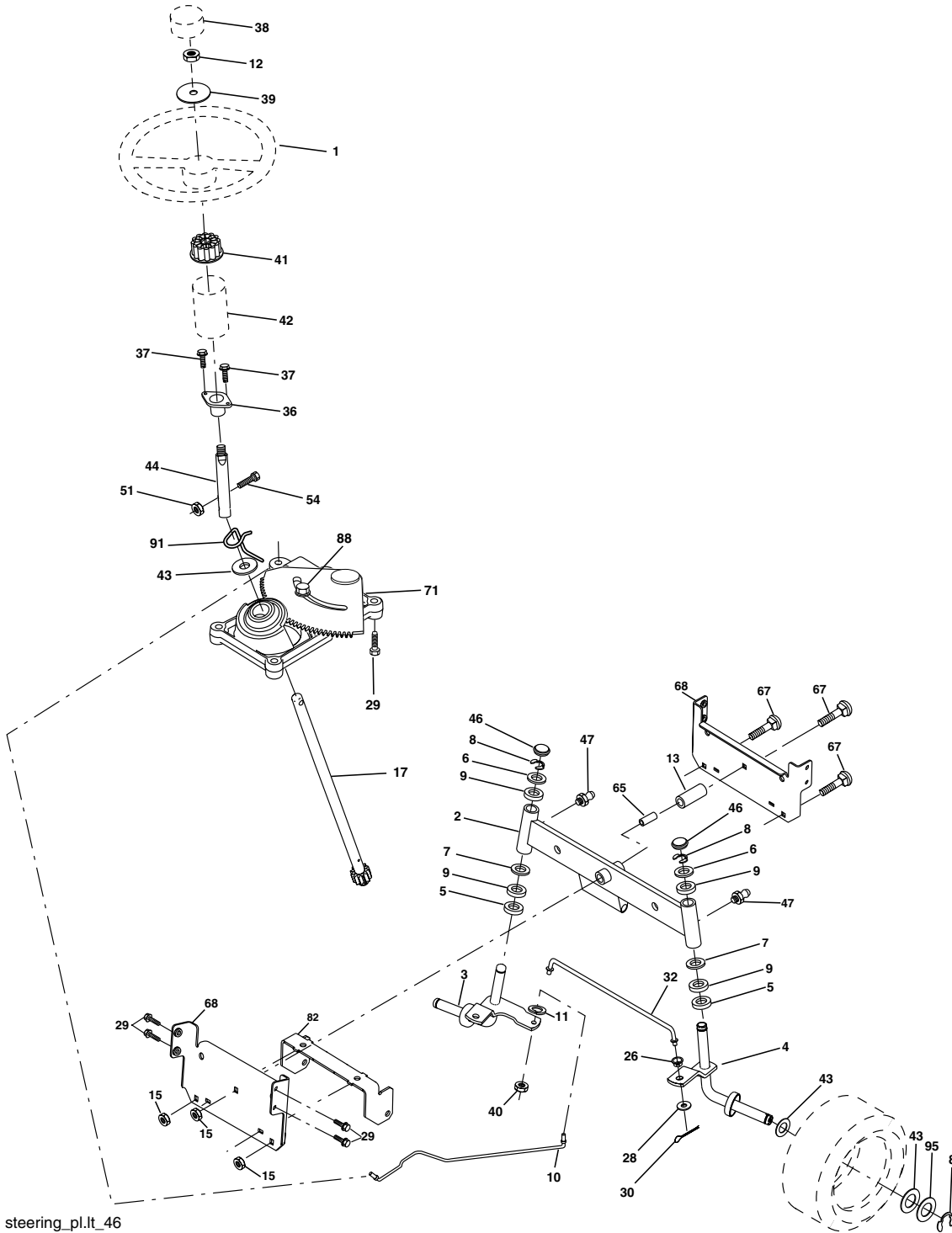

steering_pl.It_46

REPAIR PARTS

TRACTOR - - MODEL NO. LTH18542 (LTH18542C), PRODUCT NO. 954 57 17-31
STEERING ASSEMBLY

KEY NO.	PART NO.	DESCRIPTION
1	532 16 66-27	Wheel Steering
2	532 17 51-31	Axle Asm
3	532 16 98-40	Spindle Asm LH
4	532 16 98-39	Spindle Asm RH
5	532 12 49-31	Bearing Race Thrust Harden
6	532 12 17-48	Washer 25/32 x 1-5/8 x 16 Ga.
7	819 27 20-16	Washer 27/32 x 1-1/4 x 16 Ga.
8	812 00 00-29	Ring Klip #t5304-75
9	532 12 49-37	Bearing Col Strg Blk
10	532 17 51-21	Link Drag
11	810 04 06-00	Washer Lock Hvy Hlcl Spr 3/8
12	873 94 08-00	Nut Hex Jam Toplock 1/2-20 unf
13	532 13 65-18	Spacer Brg Axle Front
15	532 14 52-12	Nut Hex Flange Lock
17	532 18 06-41	Shaft Asm Strg
26	532 12 68-47	Bushing Link Drag Blk LR
28	819 13 14-16	Washer 13/32 x 7/8 x 16 Ga.
29	817 00 06-12	Screw 3/8-16 x 3/4
30	876 02 04-12	Pin Cotter 1/8 x 3/4 Cad
32	532 13 04-65	Rod Tie Wire Form 19 75 Mech
36	532 15 50-99	Bushing Strg
37	532 15 29-27	Screw
38	532 16 66-26	Cap Wheel Steering
39	819 18 24-11	Washer 9/16 ID x 1-1/2 OD 11 G. Zin
40	873 54 06-00	Nut Crownlock 3/8-24
41	532 15 99-45	Adaptor Wheel Strg
42	532 16 96-34	Boot Steering Shaft
43	532 12 17-49	Washer 25/32 x 1 1/4 x 16 Ga.
44	532 18 06-40	Extension Steering Shaft LR/LT
46	532 12 12-32	Cap Spindle Fr Top Blk
47	532 18 32-26	Fitting Grease
51	873 54 04-00	Nut Crownlock 1/4-28
54	871 13 04-20	Bolt Hex 1/4-28unf x 1-1/4 Ga. 8
65	532 16 03-67	Spacer Brace Axle
67	872 11 06-18	Bolt Rdhd SQ 3/8-16 unc x 2-1/4
68	532 16 98-27	Axle, Brace
71	532 17 51-46	Steering Asm
82	532 16 98-35	Bracket Susp Chassis Front
85	532 13 38-35	Fastner Christmas Tree
88	532 17 51-18	Bolt Shoulder 7/16-20
91	532 17 55-53	Clip Steering
95	532 18 89-67	Washer Harden .793 x 1.637 x 060

NOTE: All component dimensions given in U.S. inches.
1 inch = 25.4 mm.

REPAIR PARTS

TRACTOR - - MODEL NO. LTH18542 (LTH18542C), PRODUCT NO. 954 57 17-31
SEAT ASSEMBLY

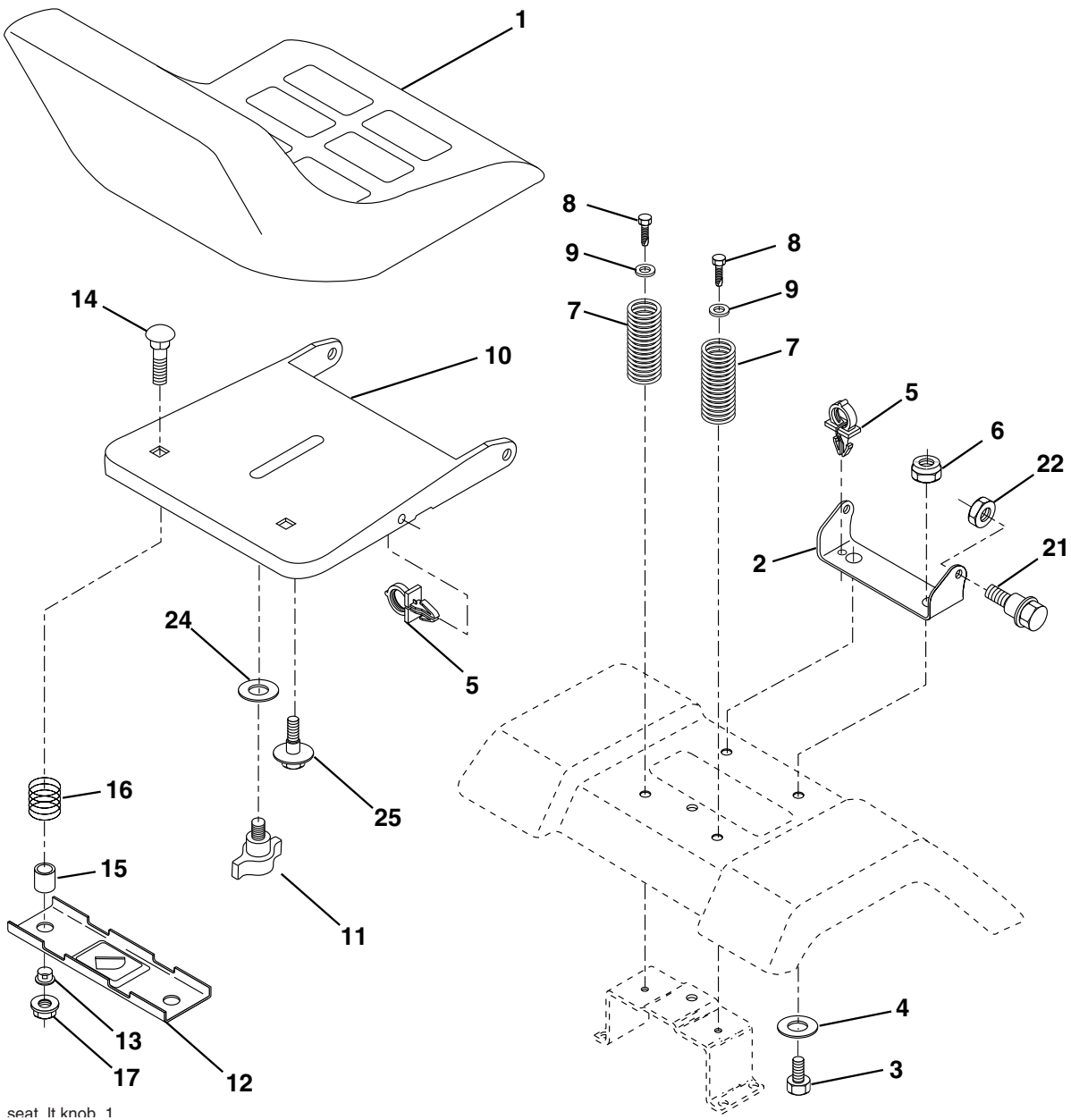

KEY NO.	PART NO.	DESCRIPTION
1	532 18 49-91	Seat
2	532 14 05-51	Bracket Pivot Seat 8 720
3	871 11 06-16	Bolt Fin Hex 3/8-16 unc x 1
4	819 13 16-10	Washer 13/32 x 1 x 10 Ga.
5	532 14 50-06	Clip Push-In
6	873 80 06-00	Nut Hex w/Ins. 3/8-16 unc
7	532 12 41-81	Spring Seat Cprsn 2 250 Blk Zi
8	817 00 06-16	Screw 3/8-16 x 1
9	819 13 16-14	Washer 13/32 x 1 x 14 Ga.
10	532 18 24-93	Pan Seat
11	532 16 63-69	Knob Seat
12	532 12 12-46	Bracket Mounting Switch

KEY NO.	PART NO.	DESCRIPTION
13	532 12 12-48	Bushing Snap Blk Nyl 50 Id
14	872 05 04-12	Bolt Rdhd Sqnk 1/4-20 x 1-1/2
15	532 13 43-00	Spacer Split 28 x 96 Yel Zinc
16	532 12 12-50	Spring Cprsn 1 27 Blk Pnt
17	532 12 39-76	Nut Lock 1/4 Lge Flg Gr. 5 Zinc
21	532 17 18-52	Bolt Shoulder 5/16-18 unc-2A
22	873 80 05-00	Nut Hex Lock W/Ins 5/16-18
24	819 17 19-12	Washer 17/32 x 1-3/16 x 12 Ga.
25	532 12 70-18	Bolt Shoulder 5/16-18 x 62

NOTE: All component dimensions given in U.S. inches.
1 inch = 25.4 mm

REPAIR PARTS

TRACTOR - - MODEL NO. LTH18542 (LTH18542C), PRODUCT NO. 954 57 17-31
DECALS

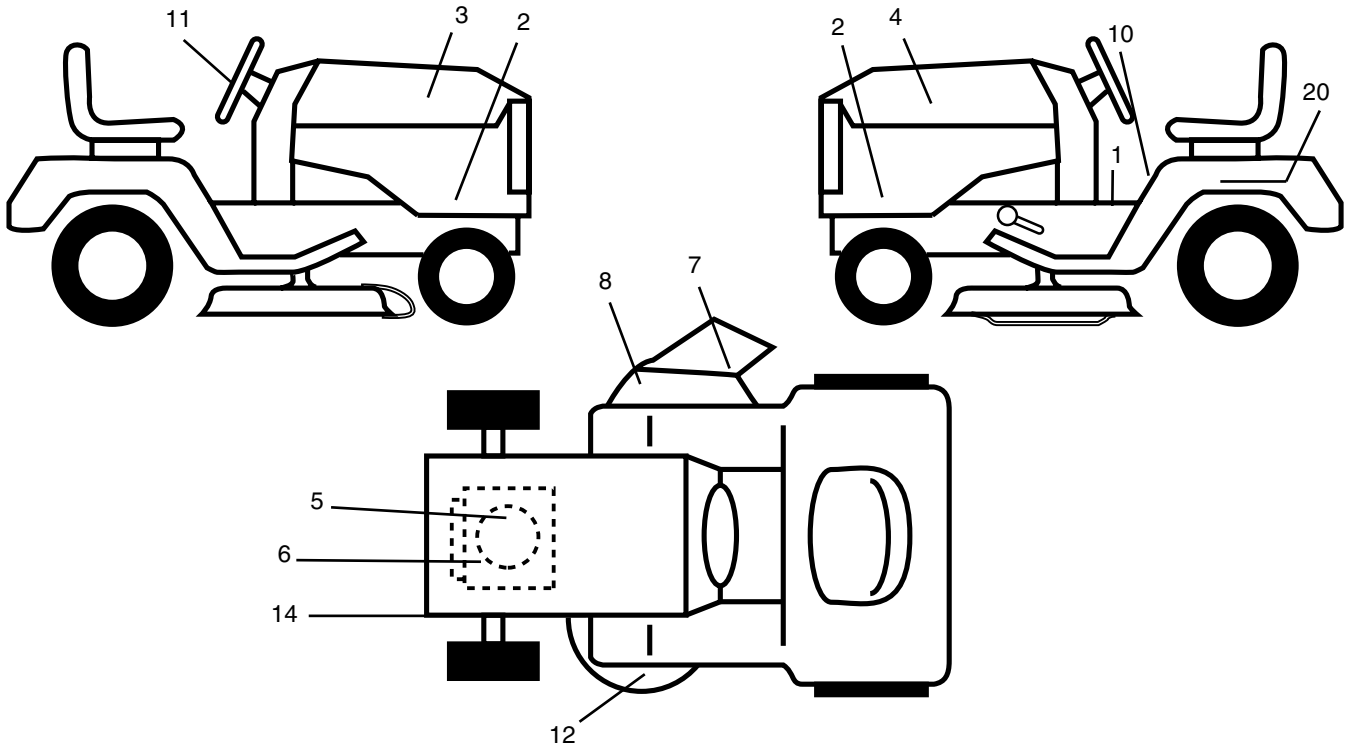

KEY NO.	PART NO.	DESCRIPTION
1	532 15 70-32	Decal Oper. Step Thru Eng/Fr
2	532 18 97-00	Decal Side Panel
3	532 18 89-16	Decal Hood RH
4	532 18 89-17	Decal Hood LH
5	532 18 09-41	Decal Hood Cust.
6	532 18 91-23	Decal Engine
7	532 17 91-28	Decal Deck B 42
8	532 17 05-63	Decal Warning
10	532 15 71-40	Decal Fender Danger Eng/Fr

KEY NO.	PART NO.	DESCRIPTION
11	532 18 89-25	Decal SW Husq Inter
12	532 17 23-31	Decal deck Sears heavyduty
14	532 16 03-96	Decal V-Belt Schematic
20	532 14 50-05	Decal Bat Dan/Psn
--	532 13 83-11	Decal Handle Lft Height Adjust
--	532 16 69-60	Decal Bypass Lt Hydro
--	532 18 96-68	Decal Replc Part
--	532 18 82-52	Pad Footrest LH
--	532 18 82-53	Pad Footrest RH
--	532 19 34-54	Manual Owner's (English)

WHEELS & TIRES

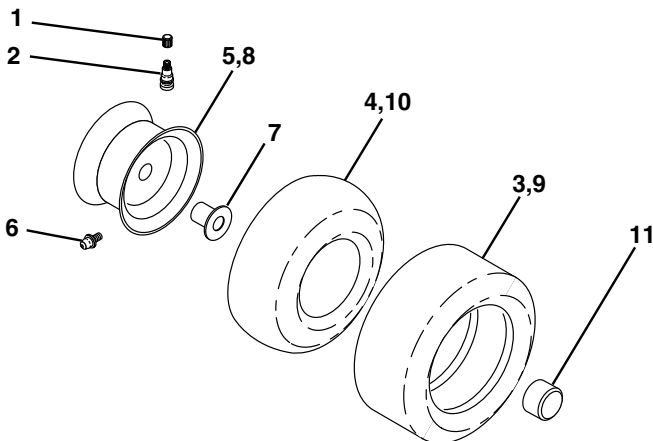

KEY NO.	PART NO.	DESCRIPTION
1	532 05 91-92	Cap Valve Tire
2	532 06 51-39	Stem Valve
3	532 10 62-22	Tire F Ts 15 X 6.0 - 6 Service
4	532 05 99-04	Tube Front (Service Item Only)
5	532 13 83-36	Rim Asm 6" front Silver Service
6	532 12 49-57	Fitting Grease (Front Wheel Only)
7	532 12 49-59	Bearing Flange (Front Wheel Only)
8	532 13 83-37	Rim Asm 8" rear Silver Service
9	532 10 62-68	Tire R Ts 18x9 5-8 C Service
10	532 12 49-26	Tube Rear (Service Item Only)
11	532 17 50-39	Cap Axle Blk 1 50 X 1 00
--	532 14 43-34	Sealant, Tire (10 oz. Tube)

NOTE: All component dimensions given in U.S. inches
1 inch = 25.4 mm

REPAIR PARTS

TRACTOR - - MODEL NO. LTH18542 (LTH18542C), PRODUCT NO. 954 57 17-31
ENGINE

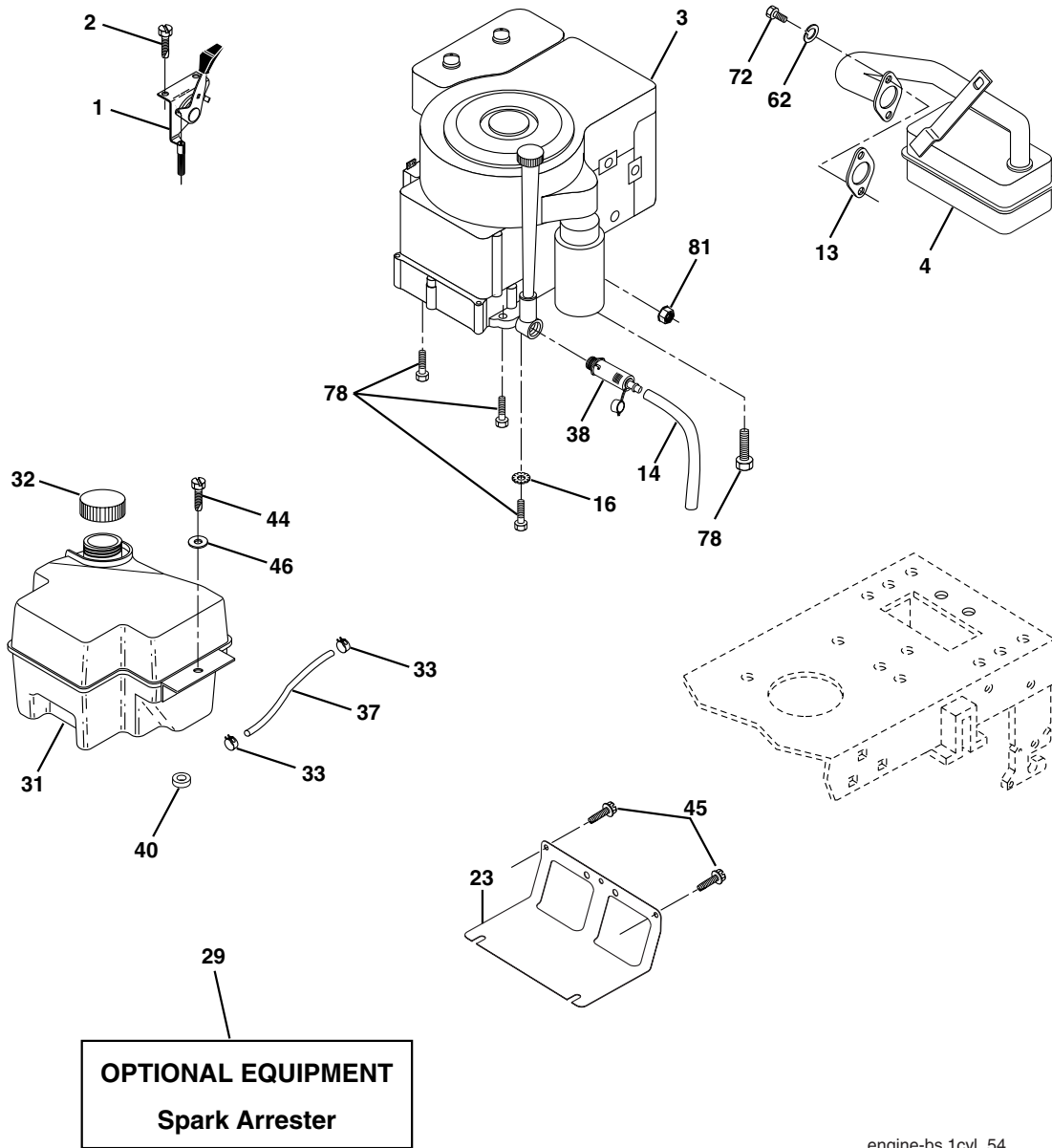

engine-bs.1cyl_54

KEY NO.	PART NO.	DESCRIPTION
1	532 17 05-51	Control Throttle/Choke
2	817 72 04-08	Screw Hex Thd Cut 1/4-20 x 1/2
3	-----	Engine, B&S 31Q777 (Order parts from engine manufacturer)
4	532 13 73-52	Muffler
13	532 16 52-91	Gasket Eng
14	532 14 84-56	Tube Drain Oil Easy
23	532 16 98-37	Shield Brn/Dbr Guard
29	532 13 71-80	Kit Spark Arrestor (Flat Scrn)
31	532 18 06-45	Tank Fuel Front
32	532 14 05-27	Cap Asm Fuel W/sym Vented
33	532 12 34-87	Clamp Hose Black
37	532 13 70-40	Line Fuel 20"
38	532 18 16-54	Plug Drain Oil Easy
40	532 12 40-28	Bushing Snap Nyl Blk Fuel Line

KEY NO.	PART NO.	DESCRIPTION
44	817 67 04-12	Screw Hexwsh Thdrol 1/4-20 x 3/4
45	817 00 06-12	Screw Hexwsh Thdr 3/8-16 x 3/4
46	819 09 14-16	Washer 9/32 x 7/8 x 16 Ga.
62	810 01 05-00	Washer Split
72	532 18 39-06	Screw Socket Head 5/16-18 x 1
78	817 06 06-20	Screw Hex Hd. Cap 5/16-18 x 3/4
81	873 51 04-00	Nut Keps Hex 1/4-20 unc

NOTE: All component dimensions given in U.S. inches
1 inch = 25.4 mm

For engine service and replacement parts, call the toll free number for your engine manufacturer listed below:

Briggs & Stratton	1-800-233-3723
Kohler Co.	1-800-544-2444
Tecumseh Products	1-800-558-5402
Honda Engines	1-800-426-7701
Kawasaki	1-949-460-5688

REPAIR PARTS

TRACTOR - - MODEL NO. LTH18542 (LTH18542C), PRODUCT NO. 954 57 17-31
MOWER LIFT

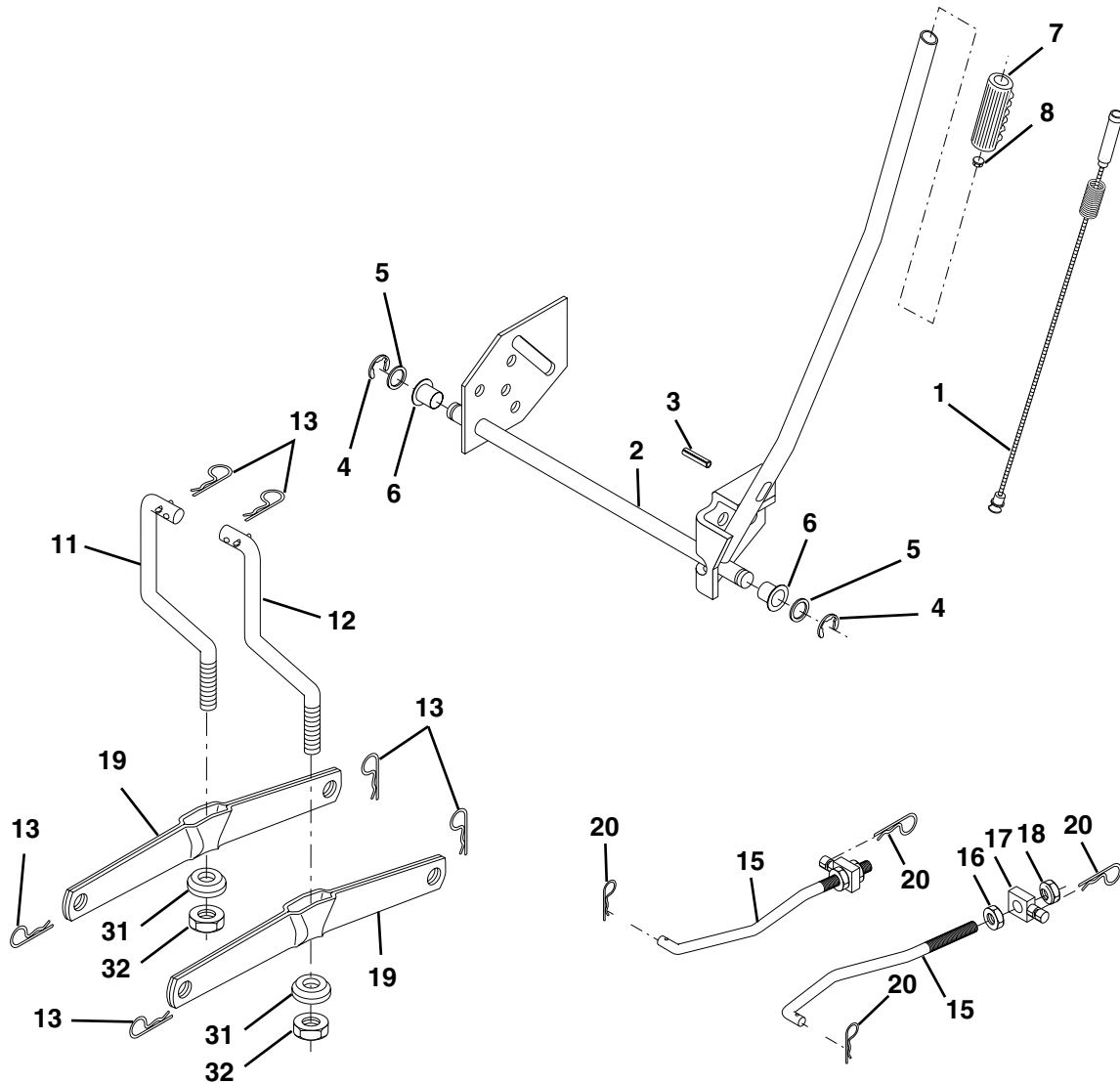

KEY NO.	PART NO.	DESCRIPTION
1	532 15 94-60	Wire Asm Inner W/plunger LT
2	532 15 94-71	Shaft Asm Lift
3	532 10 57-67	Pin Groove
4	812 00 00-02	E Ring #5133-62
5	819 21 16-21	Washer PLTD 21/32 x 1 x 21Ga.
6	532 12 01-83	Bearing Nylon Blk 629 Id
7	532 12 56-31	Grip Handle Bicycle
8	532 12 45-26	Button Plunger Black
11	532 13 98-65	Link Lift LH
12	532 13 98-66	Link Lift RH
13	532 12 46-70	Retainer Spring
15	532 17 32-88	Link Front
16	873 35 08-00	Nut Jam Hex 1/2-13 unc
17	532 17 56-89	Trunnion
18	873 80 08-00	Nut Lock W/Wsh 1/2-13 unc
19	532 13 98-68	Arm Suspension Rear
20	532 16 35-52	Spring, Retainer
31	532 16 98-65	Bearing Pvt. Lift
32	873 54 06-00	Nut Crownlock 3/8-24

NOTE: All component dimensions given in U.S. inches
1 inch = 25.4 mm

REPAIR PARTS

TRACTOR - - MODEL NO. LTH18542 (LTH18542C), PRODUCT NO. 954 57 17-31
MOWER DECK

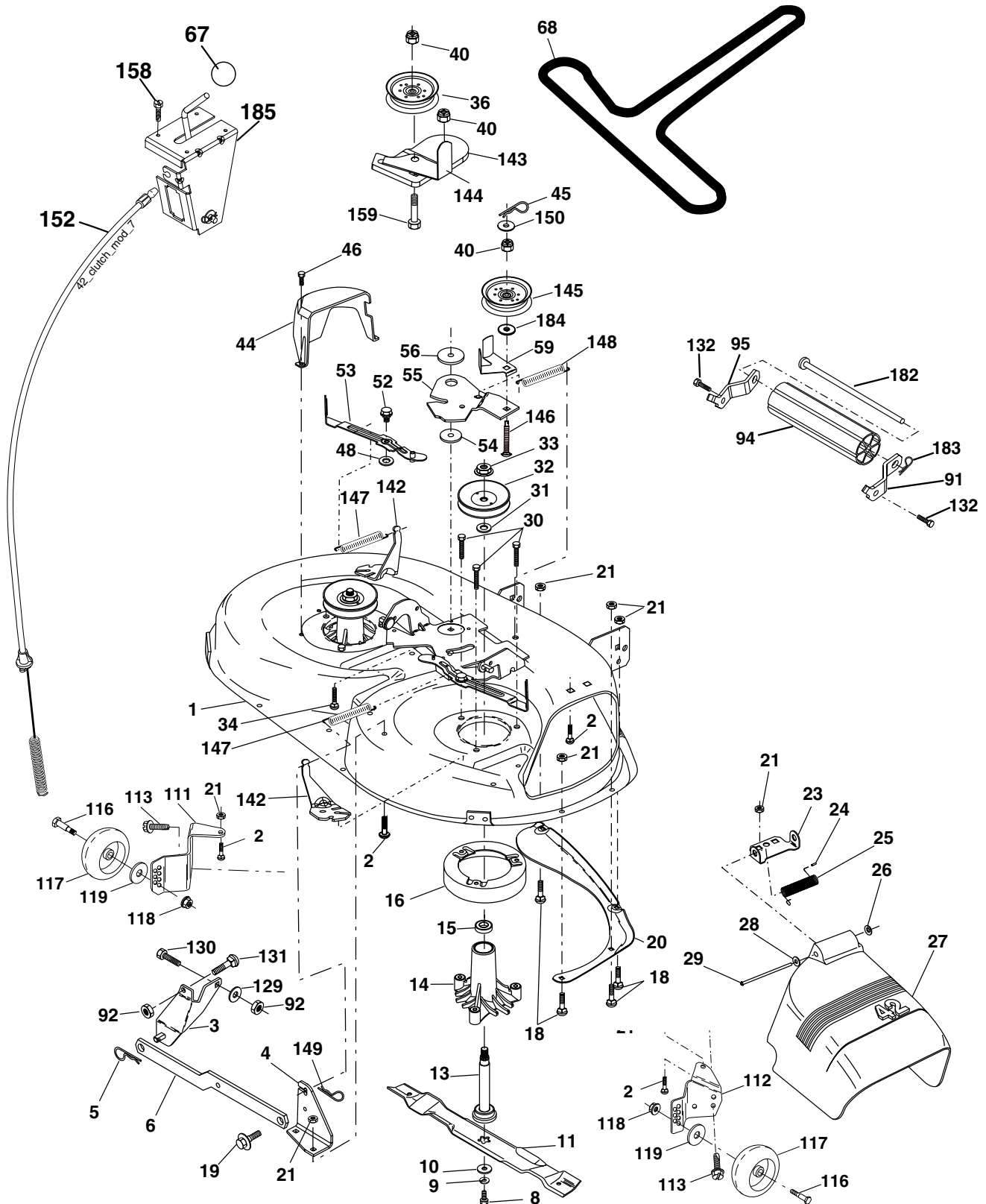

42_D_man-t-path_stit_3

REPAIR PARTS

TRACTOR - - MODEL NO. LTH18542 (LTH18542C), PRODUCT NO. 954 57 17-31 MOWER DECK

KEY NO.	PART NO.	DESCRIPTION	KEY NO.	PART NO.	DESCRIPTION
1	532 16 58-92	Deck Asm MWR 42"weldment	56	532 16 57-23	Spacer Retainer Mower
2	872 14 05-06	Bolt Rdhd Sqnk 5/16-18 unc x 3/4	59	532 14 10-43	Guard TUV Idler
3	532 13 80-17	Bracket Asm Fr Sway Bar 38/42	67	532 10 69-32	Knob Rd 3/8-16 Plstc Thds Blk
4	532 16 54-60	Bracket Asm Deck 42"sway Bar	68	532 14 49-59	V-Belt Mower 42"
5	532 12 46-70	Retainer Spring	91	532 18 05-32	Bracket Roller Nose LH
6	532 17 80-24	Deck Sway Bar	92	873 80 06-00	Nut Lock Hex w/Ins. 3/8-16 unc
8	532 85 08-57	Bolt 3/8 - 24 X 1.25 Gr 8	94	532 13 22-64	Roller Nose
9	810 03 06-00	Washer Lock Hvy 3/8	95	532 18 05-33	Bracket Roller Nose RH
10	532 14 02-96	Washer Hard Blade Mower vented (The following blades are available)	111	532 17 92-92	Bracket Wheel Gauge LH 42" Deck
11	532 13 41-49	Blade, 42" Mulching Std (For mulching mowers only)	112	532 17 92-93	Bracket Gauge Wheel RH 42" Deck
--	532 13 97-75	Blade, 42" Mulching Premium (For better wear when mulching)	113	817 00 05-10	Bolt 5/16-18
--	532 13 89-71	Blade, 42" Hi-Lift (For bagging or discharging)	116	532 12 48-42	Bolt Shoulder
13	532 13 76-45	Shaft Asm W/lower Bearing	117	532 16 57-46	Wheel Gauge
14	532 12 87-74	Housing Mandrel Vented	118	873 93 06-00	Nut Centerlock 3/8-16 unc
15	532 11 04-85	Bearing Ball Mandrel	119	819 12 14-14	Washer 3/8 x 7/8 x 14 Ga.
16	532 17 44-93	Stripper Mower	129	819 13 13-12	Washer 13/32 x 13/16 x 12 Ga.
18	872 14 05-05	Bolt Rdhd Sqnk 5/16-18 x 5/8	130	872 14 06-08	Bolt RdHd Sqnk 3/8-16 unc x 1
19	532 13 28-27	Bolt Shoulder	131	874 78 06-16	Bolt Fin Hex 3/8-16 unc x 1 Gr. 5
20	532 15 97-70	Baffle Vortex 42	132	817 00 06-12	Screw Hex Wsh Thdr. 3/8-16 x 3/4
21	873 68 05-00	Nut Crownlock 5/16-18 unc	142	532 16 58-90	Arm Spring Brake Mower
23	532 17 75-63	Bracket Deflector Mower 42"	143	532 15 71-09	Bracket Arm Idler 42"
24	532 10 53-04	Cap Sleeve 80 x 112 Blk Mower	144	532 15 86-34	Keeper Belt 42" Clutch
25	532 12 37-13	Spring Torsion Deflector 2 52	145	532 16 58-88	Pulley Idler Flat
26	532 11 04-52	Nut Push Phos & Oil	146	532 17 19-77	Bolt Carriage Idler
27	532 17 18-59	Shield Deflector Mower 42" Blk	147	532 13 13-35	Spring Extension
28	819 11 10-16	Washer 11/32 x 5/8 x 16 Ga.	148	532 16 90-22	Spring Return Idler
29	532 13 14-91	Rod Hinge 42"6 75 Wlg	149	532 16 58-98	Retainer Spring Yellow
30	532 17 39-84	Screw Thd Rolling	150	819 09 12-10	Washer 9/32 x 3/4 x 16 Ga.
31	532 18 76-90	Washer Spacer	152	532 16 96-76	Clutch Cable 42"
32	532 15 35-35	Pulley Mandrel 42"	158	817 72 04-08	Screw Hex Thd Cut 1/4-20 x 1/2
33	532 17 83-42	Nut Toplock Fng	159	872 14 06-14	Bolt Rdhd Sqn 3/8-16 unc x 1-3/4
34	872 11 06-12	Bolt Carr SH 3/8-16 x 1-1/2 Gr. 5	182	532 17 91-26	Rod Roller Nose
36	532 13 14-94	Pulley Idler Flat 3 060	183	532 16 35-52	Retainer Spring
40	873 90 06-00	Nut Lock FLg 3/8-16 unc	184	819 13 14-10	Washer 13/32 x 7/8 x 10 Ga.
44	532 14 00-88	Guard Mandrel LH Black	185	532 18 82-34	Head Asm Cable Clutch
45	532 12 47-88	Spring Retainer 1" Zinc/cad	--	532 13 07-94	Mandrel Assembly(Includes Hous- ing, Shaft and Shaft Hardware Only-Pulley not Included)
46	532 13 77-29	Screw Hex Thd Cut 1/4-20 x 5/8 T	--	532 17 14-91	Replacement Mower, Complete (Std Deck-order separately nose roller and gauge wheel compo- nents key nos. 91, 94, 95, 132, 182, 183, 116-119)
48	532 13 39-44	Washer Hardened Smaller			
52	532 13 98-88	Bolt Shoulder 5/16-18 unc Blkz			
53	532 18 49-07	Arm Asm Pad Brake			
54	532 17 85-15	Washer Hardened			
55	532 15 50-46	Arm Idler 42"mower LT/YT			

NOTE: All component dimensions given in U.S. inches
1 inch = 25.4 mm