

YTH2148 XP

Spare parts
Ersatzteile
Pièces détachées
Reserve onderdelen
Repuestos
Reservdelar

TRACTOR - MODEL NUMBER YTH2148XP (HAU21H48B), PRODUCT NO. 954 17 02-27 SCHEMATIC

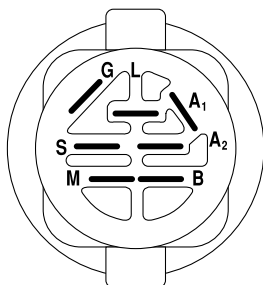
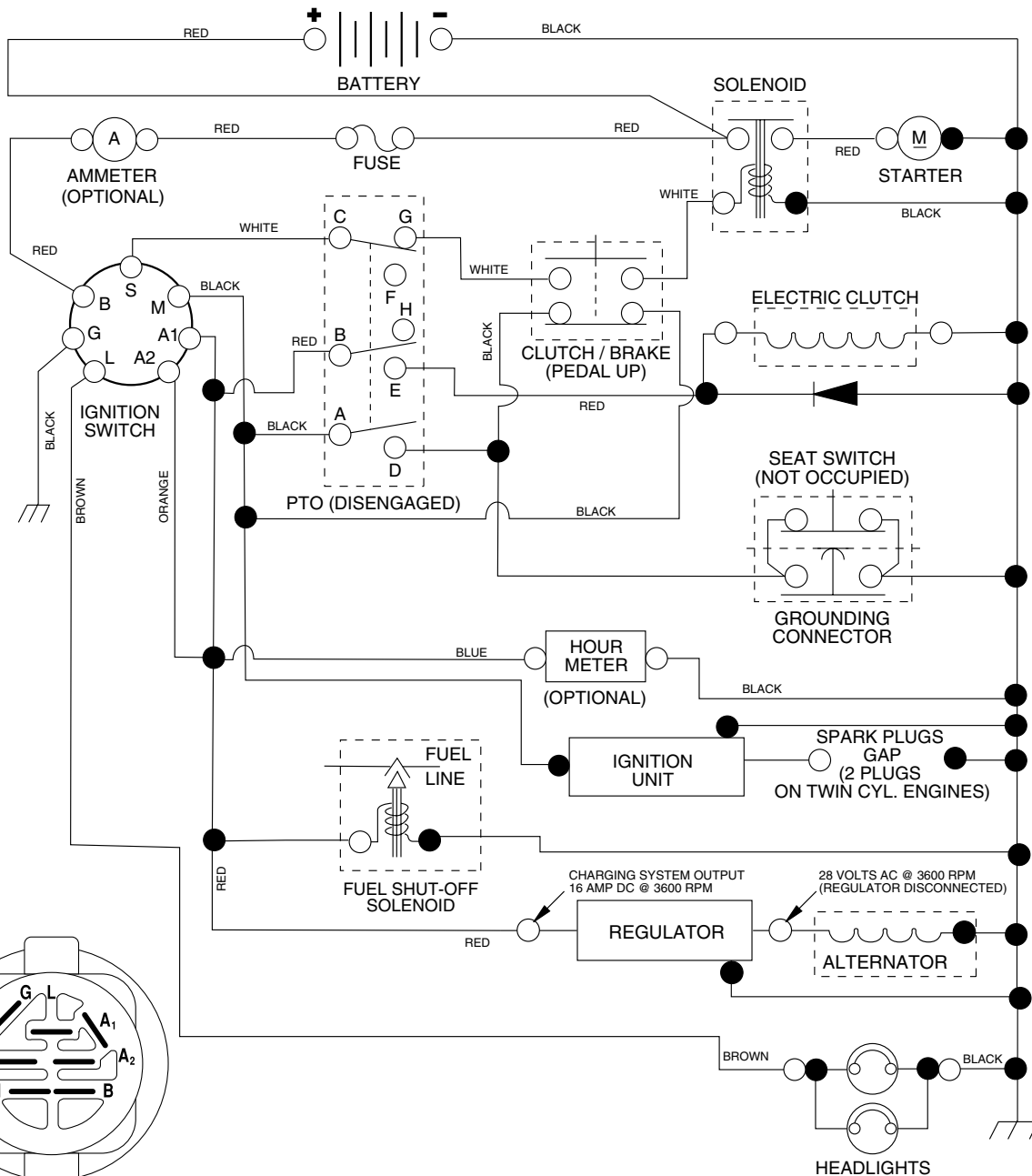

IGNITION SWITCH

POSITION	CIRCUIT	"MAKE"
OFF	M + G + A1	NONE
ON + LIGHTS	B + A1	L + A2
ON	B + A1	NONE
START	B + S + A1	NONE

WIRING INSULATED CLIPS
NOTE: IF WIRING INSULATED CLIPS WERE REMOVED FOR SERVICING OF UNIT, THEY SHOULD BE REPLACED TO PROPERLY SECURE YOUR WIRING.

02769

PTO SWITCH

POSITION	CIRCUIT
OFF	C + G, B + H
ON	C + F, B + E, A + D

○
REMOVABLE CONNECTIONS

●
NON-REMOVABLE CONNECTIONS

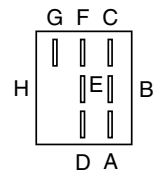

PTO SWITCH CONNECTOR

REPAIR PARTS

TRACTOR - MODEL NUMBER YTH2148XP (HAU21H48B), PRODUCT NO. 954 17 02-27

ELECTRICAL

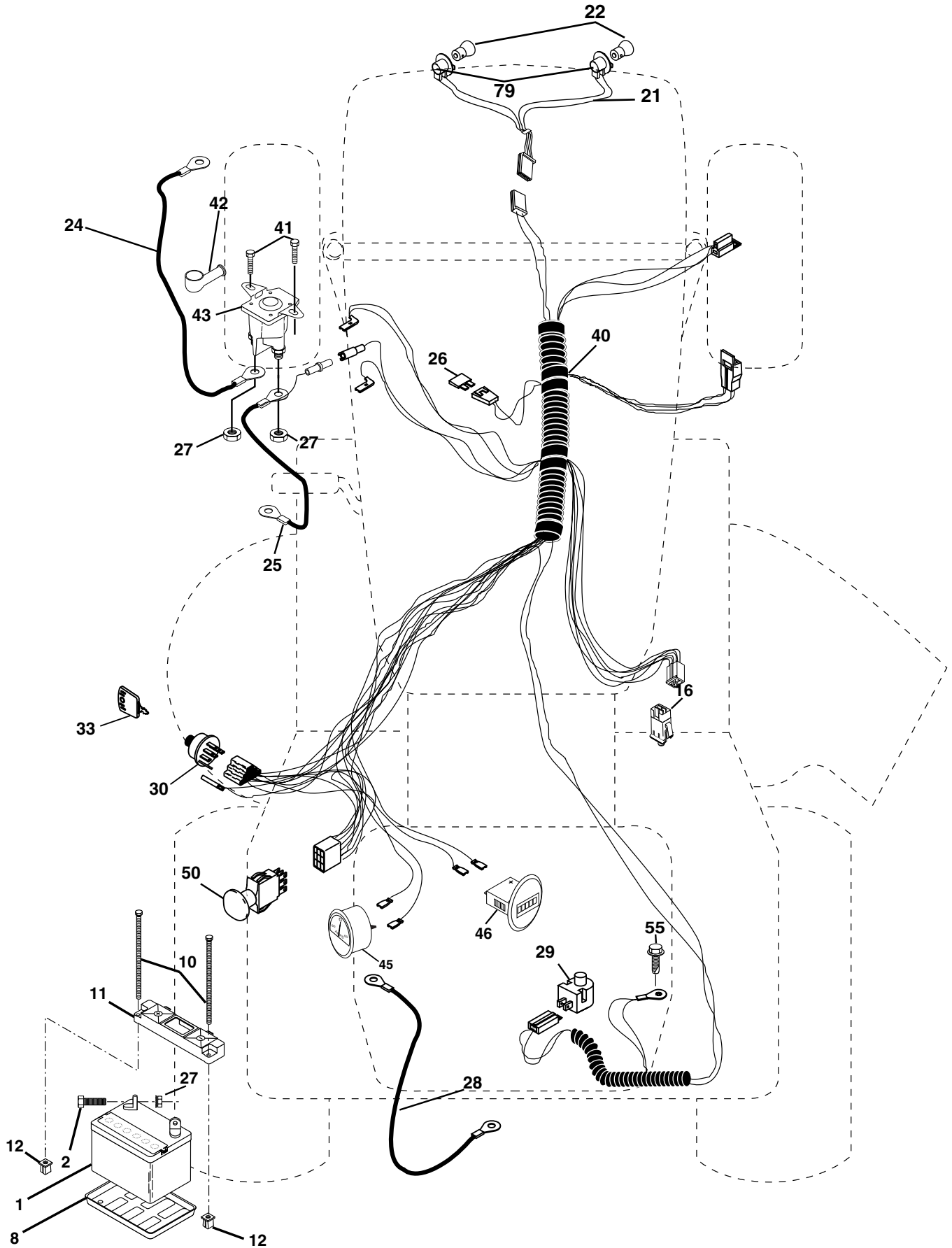

REPAIR PARTS

TRACTOR - MODEL NUMBER YTH2148XP (HAU21H48B), PRODUCT NO. 954 17 02-27
ELECTRICAL

KEY NO.	PART NO.	DESCRIPTION
1	532 14 49-27	Battery 12 Volt 35 AMP
2	874 76 04-12	Bolt Hex Hd 1/4-20 unc x 3/4
8	532 12 48-86	Tray Battery
10	532 14 52-11	Bolt Brt Frt 1/4-20 x 75 Zinc
11	532 15 01-09	Holddown Battery Front Mount
12	532 14 57-69	Nut Push Nylon 1/4" Battery Frt
16	532 17 61-38	Switch Interlock
21	532 17 56-88	Harness Asm Light W/4152j
22	532 00 41-52	Bulb Light #1156
24	532 00 88-60	Cable Battery 6 Ga. 17" red
25	532 14 61-48	Cable Battery 6 Ga. 22" red w/16 wire
26	532 17 51-58	Fuse
27	873 51 04-00	Nut Keps Hex 1/4-20 unc
28	532 14 54-91	Cable Ground 6 Ga. 21" black
29	532 12 13-05	Switch Plunger Nc Gray
30	532 17 55-66	Switch Ign
33	532 14 04-01	Key Ign Molded Generic
40	532 18 80-30	Harness Ign.
41	817 72 04-08	Screw 1/4-20 x 1/2
42	532 13 15-63	Cover Terminal Red
43	532 17 88-61	Solenoid
45	532 17 75-00	Ammeter
46	532 17 75-01	Meter Hour
50	532 17 46-51	Switch PTO
55	817 49 05-08	Screw Thdrol 5/16-18 x 1-1/2 Tyt
79	532 17 52-42	Socket Asm Bulb

NOTE: All component dimensions given in U.S. inches.
1 inch = 25.4 mm.

REPAIR PARTS

TRACTOR - MODEL NUMBER YTH2148XP (HAU21H48B), PRODUCT NO. 954 17 02-27
CHASSIS AND ENCLOSURES

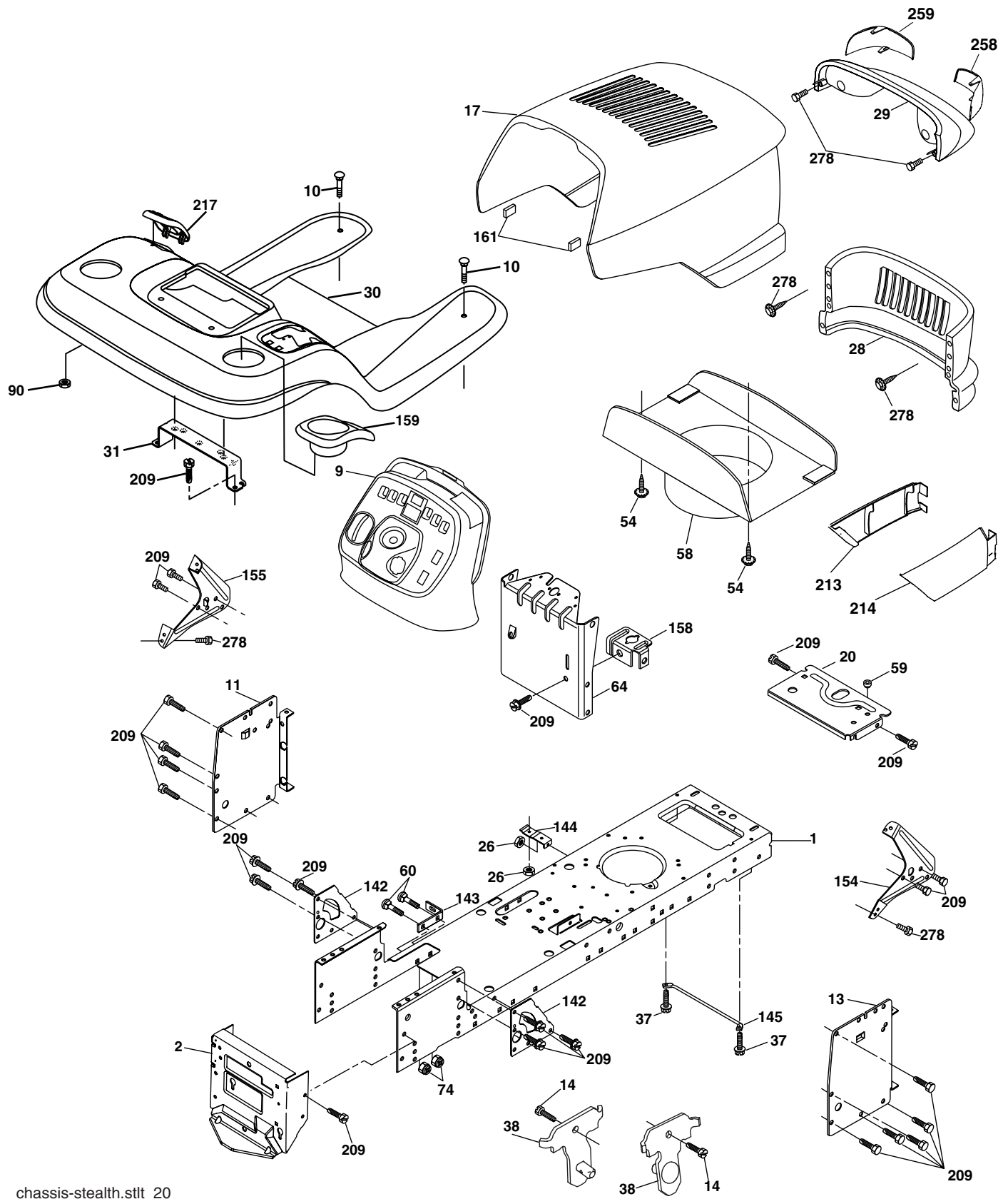

REPAIR PARTS

TRACTOR - MODEL NUMBER YTH2148XP (HAU21H48B), PRODUCT NO. 954 17 02-27 CHASSIS AND ENCLOSURES

KEY NO.	PART NO.	DESCRIPTION
1	532 17 46-19	Chassis Stamping
2	532 17 65-54	Drawbar
9	532 19 58-86	Dash
10	872 14 06-08	Bolt Rdhd Sqnk 3/8-16 unc x 1
11	532 16 72-03	Panel Dash Lh
13	532 17 82-98	Panel Dash Rh
14	817 49 06-08	Screw Thdrol 3/8-16 x 1/2
17	532 19 00-55	Hood
20	532 16 20-26	Plate Mtg Battery/Fuel Tank
26	873 80 06-00	Nut Lock w/Insert 3/8-16 unc
28	532 18 28-73	Grille
29	532 18 82-12	Light Box Asm (w/Lens)
30	532 19 48-06	Fender
31	532 13 99-76	Bracket
37	817 49 05-08	Screw Thdrol 5/16-18 x 1/2
38	532 17 57-10	Bracket Asm Pivot Mower Rear
54	532 19 25-12	Screw Hex Wshd 10-32 x 5/8
58	532 19 03-08	Duct Air
59	532 18 74-95	Bushing Snap
60	872 14 06-06	Bolt RDHD SQNK 3/8-16 x 3/4
64	532 17 49-97	Dash Lower Stlt
74	873 68 06-00	Nut Crownlock 3/8-16
90	532 12 43-46	Nut Self Thd Wsh-Hd 1/4
142	532 17 57-02	Plate Reinforcement
143	532 18 66-89	Bracket Swaybar Chassis
144	532 17 55-82	Bracket Ft Rest
145	532 15 65-24	Rod Pivot Chassis Hood
154	532 16 18-97	Bracket Dash RH
155	532 16 19-00	Bracket Dash LH
158	532 16 20-37	Parking Brake Brkt
159	532 19 24-04	Cupholder
161	532 16 46-55	Extrusion Bumper
166	532 17 18-75	HWHDH:-Lo. #13-16 x 3/4
209	817 00 06-12	Screw Hexwsh Thdr 3/8-16 c-x 3/4
213	532 17 75-87	Skirt Grille LH
214	523 17 75-86	Skirt Grille RH
217	532 18 54-36	Console Fuel Window
258	532 16 18-42	Lens RH
259	532 16 18-41	Lens LH
278	532 19 16-11	Screw 10 x 3/4 Single Lead-Hex
--	532 19 39-35	Plug Switch Light

NOTE: All component dimensions given in U. S. inches
1 inch = 25.4 mm

REPAIR PARTS

TRACTOR - MODEL NUMBER YTH2148XP (HAU21H48B), PRODUCT NO. 954 17 02-27

DRIVE

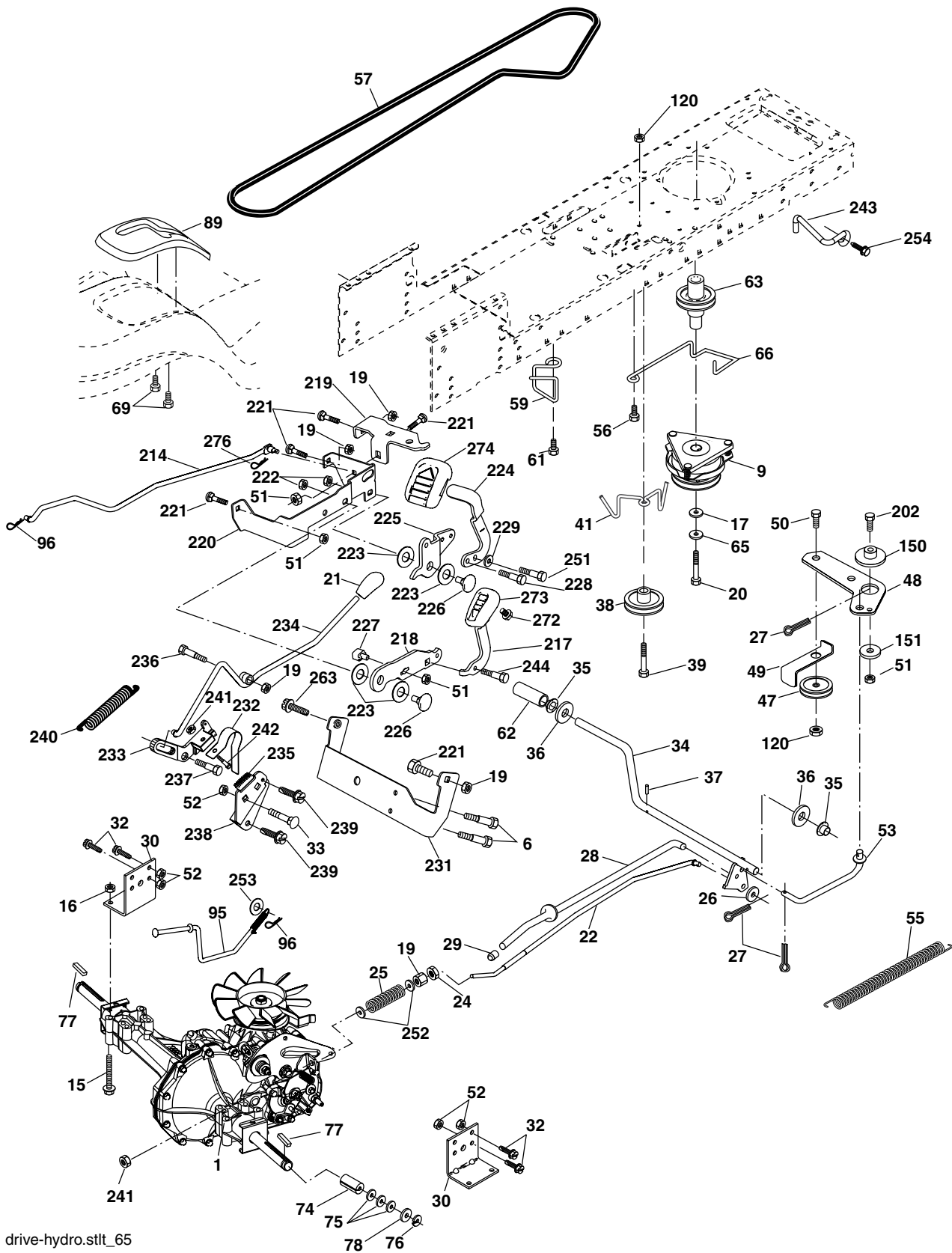

REPAIR PARTS

**TRACTOR - MODEL NUMBER YTH2148XP (HAU21H48B), PRODUCT NO. 954 17 02-27
DRIVE**

KEY NO.	PART NO.	DESCRIPTION	KEY NO.	PART NO.	DESCRIPTION
1	-----	Transaxle Hydro Gear Model 336-0510 (Order parts from transaxle manufacturer)	77	532 12 35-83	Key, Square
6	817 06 05-12	Screw 5/16-18 x 3/4	78	532 12 17-48	Washer 25/32 x 1-5/8 x 16 Ga.
9	532 17 93-34	Clutch Elec	89	532 19 19-15	Console, Shift
15	874 49 05-44	Bolt Hex Flghd 5/16-18 Gr. 5	95	532 18 08-25	Bypass Asm
16	873 80 05-00	Nut Lock Hex W/Ins. 5/16-18 unc	96	532 12 47-88	Retainer Spring 1" Zinc/Cad
17	532 12 61-97	Washer 1-1/2 OD x 15/32 ID x .250	120	873 90 06-00	Nut Lock Flg 3/8-16 unc
19	873 80 06-00	Nut Lock Hex W/Wsh 3/8-16 unc	150	532 17 54-56	Spacer Retainer
20	532 17 39-37	Bolt Hex 7/16-20 x 4 x Gr. 5-1.5	151	819 13 32-10	Washer 13/32 x 2 x 10 Ga.
21	532 18 14-54	Knob Custom Control Cruise	202	872 11 06-14	Bolt Rdhd 3/8-16 x 1-3/4 Gr. 5
22	532 17 58-96	Rod, Brake	214	532 17 47-35	Link Transaxle
24	873 35 06-00	Nut, Hex Jam 3/8-16 unc	217	532 17 94-33	Pedal Reverse Asm
25	532 19 20-36	Spring, Brake Rod	218	532 17 47-13	Arm Control Pedal Reverse
26	819 13 13-16	Washer	219	532 17 48-39	Bracket Frest Pdl Ctrl. Hyd
27	876 02 04-12	Pin Cotter 1/8 x 3/4 CAD.	220	532 17 47-11	Bracket Mtg. Pedal Control
28	532 17 57-65	Rod, Parking Brake	221	872 14 06-06	Bolt Rdhd Sqnk 3/8-16 unc x 3/4
29	532 07 16-73	Cap, Brake, Park	222	873 68 07-00	Nut Crownlock 7/16-14 unc
30	532 16 95-92	Bracket, Transaxle	223	532 17 48-40	Washer Nylon 11/16 ID x .060
32	874 76 05-12	Bolt Hex Hd 5/16-18 unc x 3/4	224	532 17 47-36	Pedal Forward
33	872 14 05-06	Bolt Rdhd Sqnk 5/16-18 unc x 3/4	225	532 17 47-12	Arm Control Pedal Forward
34	532 17 55-78	Shaft, Foot Pedal	226	532 17 49-02	Bolt Pivot Spacer
35	532 12 01-83	Bearing, Nylon	227	532 17 47-10	Cam Reverse Pedal LT
36	819 21 16-16	Washer	228	532 17 90-32	Bolt Shoulder 5/16-18
37	532 12 49-63	Pin, Roll	229	532 17 64-51	Washer Serrated 5/16 x .75
38	532 17 91-14	Pulley, Composite, Flat	231	532 17 45-73	Strap Torque
39	872 11 06-22	Bolt Rdhd 3/8-16 unc x 2-3/4 Gr. 5	232	532 17 55-70	Actuator Cruise Disengage
41	532 17 55-56	Keeper, Belt Idler Flat	233	532 17 48-56	Pawl Control Cruise
47	532 12 77-83	Pulley, Idler, V-Groove	234	532 17 48-58	Lever Control Cruise
48	532 15 44-07	Bellcrank Clutch Grnd Drw Stl	235	532 17 48-57	Sector Control Cruise
49	532 12 32-05	Retainer, Belt	236	532 12 89-03	Bolt Shoulder 3/8-16 unc 1/44
50	872 11 06-12	Bolt	237	532 17 01-65	Bolt Shoulder 5/16-18
51	873 68 06-00	Nut Crownlock 3/8-16 unc	238	532 17 58-07	Arm Mtg. Cruise Sector
52	873 68 05-00	Nut, Crownlock 5/16-18 unc	239	817 49 05-08	Screw Thdrol 5/16 x 1/2
53	532 10 57-10	Link, Clutch	240	532 17 56-10	Spring Return Cruise Control
55	532 10 57-09	Spring, Return, Clutch	241	873 93 04-00	Nut Centerlock 1/4-20 unc
56	817 06 06-20	Screw 3/8-16 x 1-1/4	242	874 78 04-12	Bolt Fin Hex 1/4-20 unc x .75
57	532 14 02-94	V-Belt, Ground Drive	243	532 19 07-36	Bracket Anti-Rotation
59	532 16 96-91	Keeper, Center Span	244	817 49 05-10	Screw 5/16-18 x 5/8
61	817 12 06-14	Screw 3/8-16 x .875	251	817 06 05-16	Screw 5/16-18 x 1
62	532 12 48-72	Cover, Pedal	252	819 13 16-16	Washer 13/32 x 1 x 16 Ga.
63	532 17 46-07	Pulley, Engine	253	532 17 94-22	Washer .3125 x .615 x 16 Ga.
65	810 04 07-00	Washer	254	817 00 06-16	Screw 3/8-16 x 1
66	532 15 47-78	Keeper Belt Engine	271	817 00 06-12	Screw Hexwsh Thdr 3/8-16 x 3/4
69	532 14 24-32	Screw Hex Wsh Hi-Lo 1/4-1/2 unc	272	817 67 05-08	Screw Thdrol 5/16-18 x 1/2
74	532 13 70-57	Spacer, Axle	273	532 17 96-10	Pad Pedal Reverse
75	532 12 17-49	Washer 25/32 x 1-1/4 x 16 Ga.	274	532 17 56-46	Cover Pedal Forward
76	812 00 00-01	E-Ring			

NOTE: All component dimensions given in U.S. inches
1 inch = 25.4 mm.

REPAIR PARTS

TRACTOR - MODEL NUMBER YTH2148XP (HAU21H48B), PRODUCT NO. 954 17 02-27
STEERING ASSEMBLY

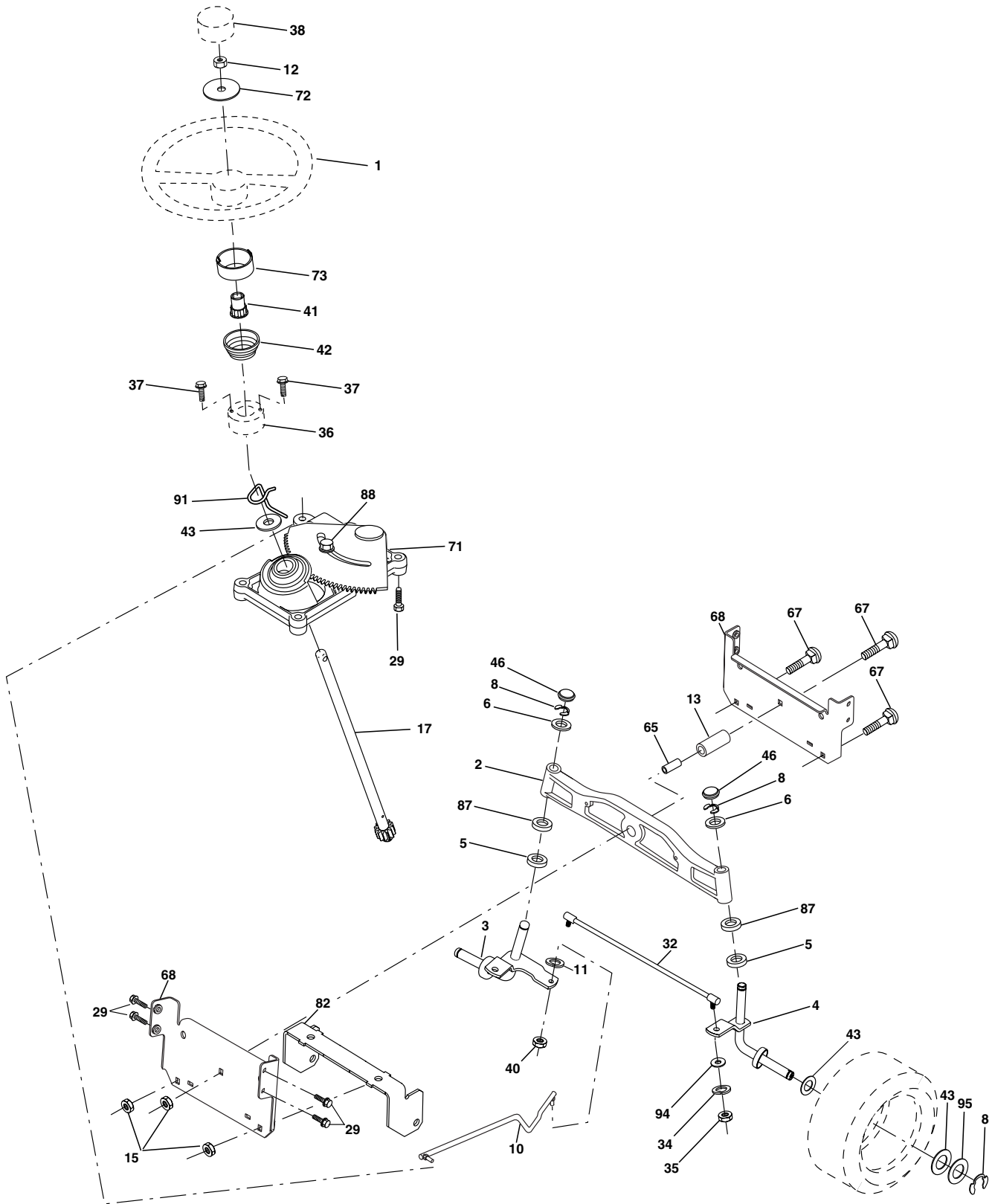

REPAIR PARTS

TRACTOR - MODEL NUMBER YTH2148XP (HAU21H48B), PRODUCT NO. 954 17 02-27
STEERING ASSEMBLY

KEY NO.	PART NO.	DESCRIPTION
1	532 19 36-51	Wheel Steering
2	532 18 47-06	Axle Casting Iron Lt
3	532 16 98-40	Spindle Asm LH
4	532 16 98-39	Spindle Asm RH
5	532 12 49-31	Washer Thrust .75 x 1.230
6	532 12 17-48	Washer 25/32 x 1-5/8 x 16 Ga.
8	812 00 00-29	Ring Klip #t5304-75
10	532 17 51-21	Draglink
11	810 04 06-00	Washer Lock Hvy Hlcl Spr 3/8
12	873 94 08-00	Nut Hex Jam Toplock 1/2-20 unf
13	532 13 65-18	Spacer Bearing Axle Front
15	532 14 52-12	Nut Hex Flange Lock
17	532 17 78-83	Shaft Asm Strg
29	817 00 06-12	Screw 3/8-16 x 3/4
32	532 18 05-80	Rod Asm Tie
34	810 04 06-00	Washer Lock Hvy HLCL Spr. 3/8
36	532 15 51-05	Bushing Strg
37	532 15 29-27	Screw TT #32.5 x 5 x 3/8 Flange
38	532 19 36-52	Insert Cap Strg Wh
40	873 54 06-00	Nut Crownlock 3/8-24
41	532 18 67-37	Adaptor Wheel Strg
42	532 19 01-12	Boot Steering
43	532 12 17-49	Washer 25/32 x 1 1/4 x 16 Ga.
46	532 12 12-32	Cap Spindle Fr Top Blk
65	532 16 03-67	Spacer Axle Brace
67	872 11 06-18	Bolt Rdhd Sqnk 3/8-16 unc x 2-1/4
68	532 16 98-27	Brace Axle
71	532 17 51-46	Steering Asm.
72	819 18 24-11	Washer 9/16 ID x 1-1/2 OD 11 Ga. Zin
73	532 17 75-93	Extension Steering Premuim
82	532 16 98-35	Bracket Susp Chassis Front
87	532 17 39-66	Washer Flat .781 x 1-1/2 x .14
88	532 17 51-18	Bolt Shoulder 7/16-20
91	532 17 55-53	Clip Steering
94	819 12 14-14	Washer 3/8 x 7/8 x 14 Ga.
95	532 18 89-67	Washer Harden .793 x 1.637 x 060

NOTE: All component dimensions given in U.S. inches
1 inch = 25.4 mm.

REPAIR PARTS

TRACTOR - MODEL NUMBER YTH2148XP (HAU21H48B), PRODUCT NO. 954 17 02-27
ENGINE

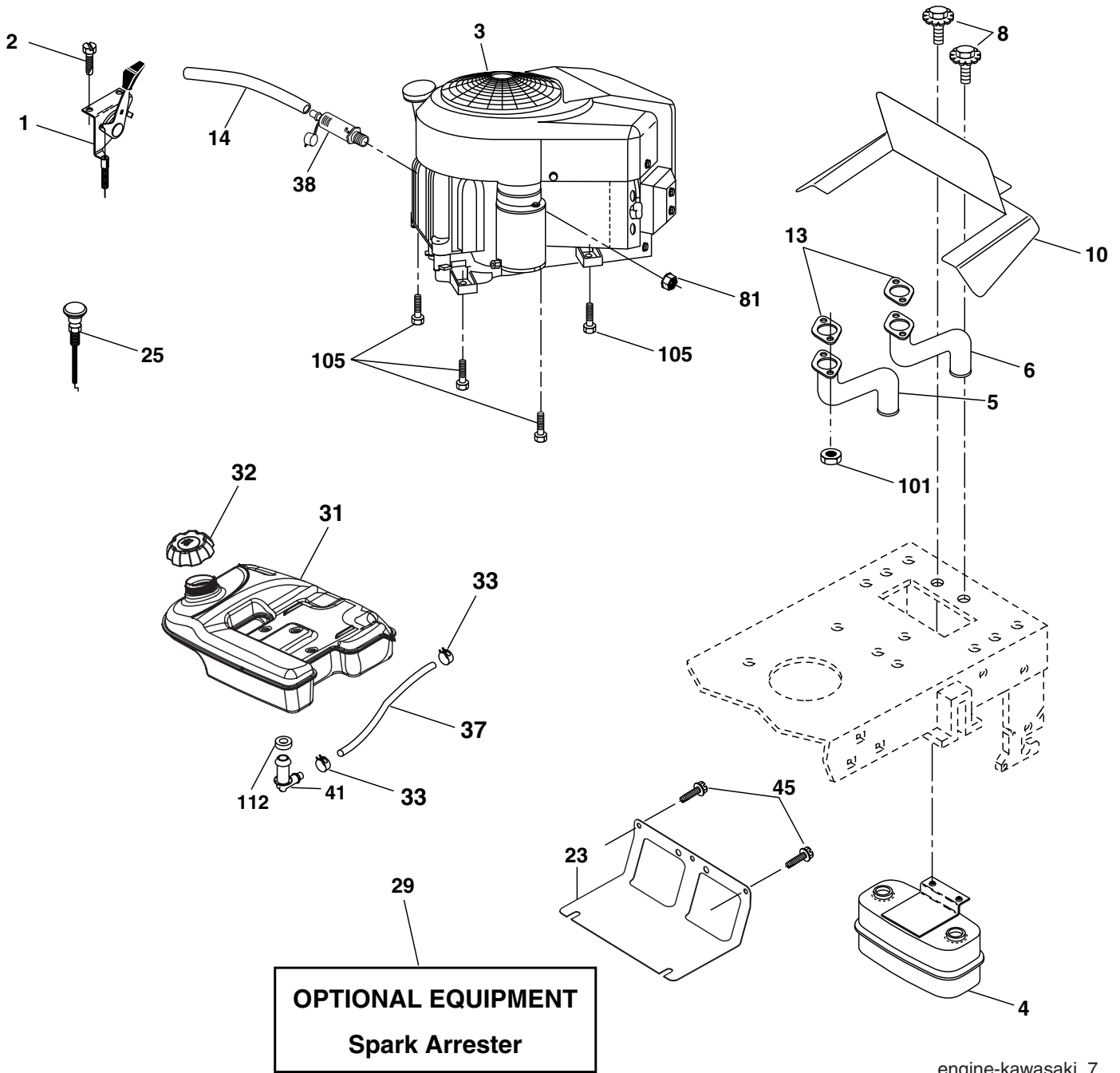

REPAIR PARTS

TRACTOR - MODEL NUMBER YTH2148XP (HAU21H48B), PRODUCT NO. 954 17 02-27
ENGINE

KEY NO.	PART NO.	DESCRIPTION
1	532 17 81-47	Control Throttle
2	532 19 16-11	Screw 10 x 3/4 Single Lead Hex
3	-----	Engine KAWA FH641 (Order Parts from Engine Manufacturer)
4	532 14 97-23	Muffler Asm Twin Lo-Tone
5	532 18 45-79	Exhaust Tube LH
6	532 18 45-80	Exhaust Tube RH
8	532 17 18-77	Bolt 5/16-18 unc x 3/4 W/Sems
10	532 14 66-29	Shield Browning
13	-----	Gasket Muffler (Order from Engine Manufacturer)
14	532 14 84-56	Tube Drain Oil Easy
23	532 16 98-37	Shield Browning
25	532 19 15-96	Control Choke
29	532 13 71-80	Kit Spark Arrestor (Flat Scrn)
31	532 17 90-22	Tank Fuel
32	532 18 18-03	Cap Asm Fuel
33	532 12 34-87	Clamp Hose Blk
37	532 14 21-58	Line Fuel
38	-----	Plug Drain Oil (Order from Engine Manufacturer)
41	532 13 92-77	Stem Tank Fuel
45	817 00 06-12	Screw Hexwsh Thdr 3/8-16 x 3/4
81	873 51 04-00	Nut Keps Hex 1/4-20 unc
101	532 18 43-62	Nut Flange M8-1.25
105	817 12 06-16	Screw 3/8-16 x 1
112	532 12 49-52	Bushing

NOTE: All component dimensions given in U.S. inches
1 inch = 25.4 mm

REPAIR PARTS

TRACTOR - MODEL NUMBER YTH2148XP (HAU21H48B), PRODUCT NO. 954 17 02-27
SEAT ASSEMBLY

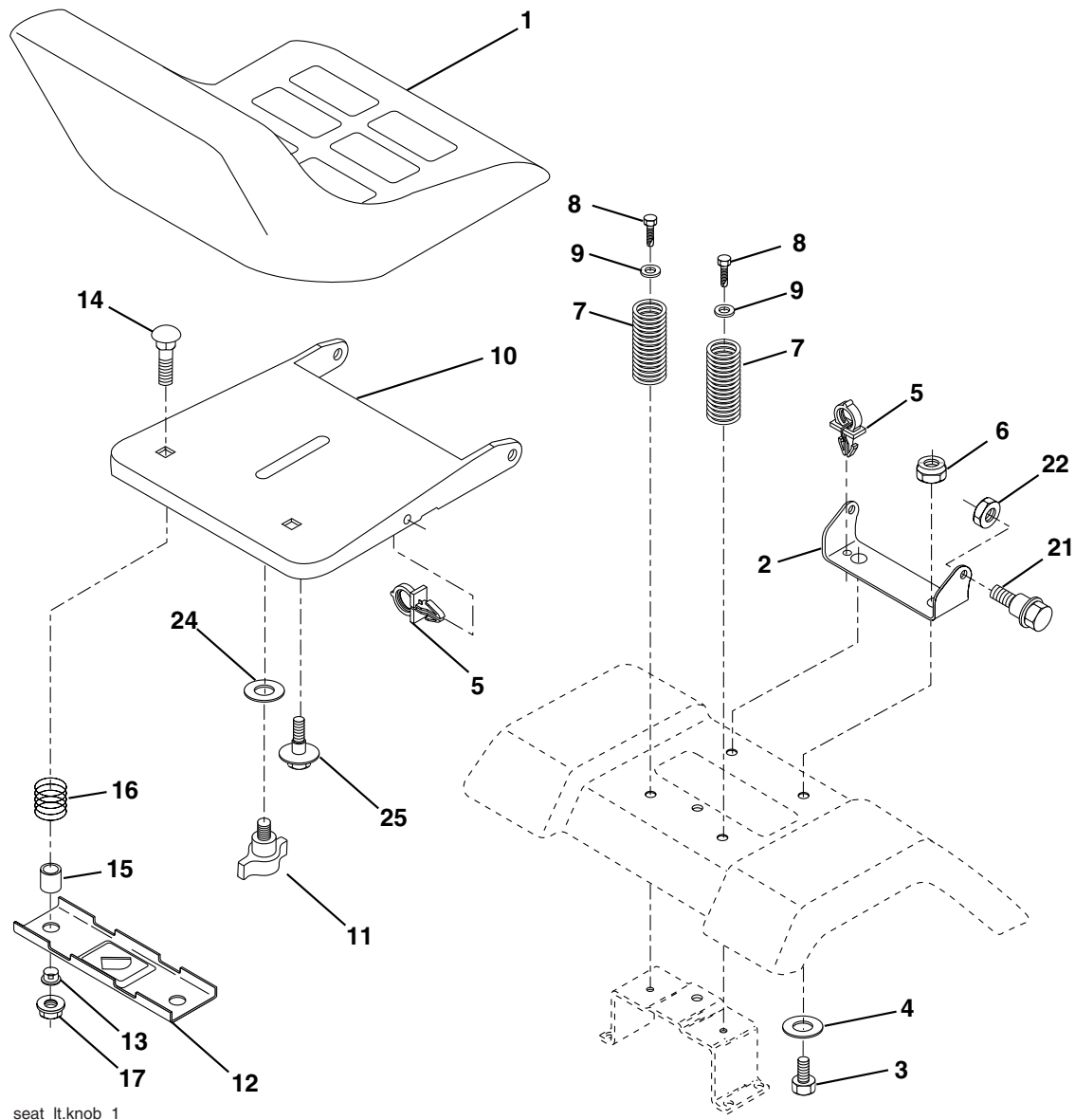

seat_lt.knob_1

KEY NO.	PART NO.	DESCRIPTION
1	532 18 87-15	Seat
2	532 14 05-51	Bracket Pivot Seat 8 720
3	871 11 06-16	Bolt Fin Hex 3/8-16 x 1
4	819 13 16-10	Washer Flat 13/32 x 1.0 x 10 Ga.
5	532 14 50-06	Clip Push-In
6	873 80 06-00	Nut Hex w/Ins. 3/8-16 unc
7	532 12 41-81	Spring Seat Cprsn 2 250 Blk Zi
8	817 00 06-16	Screw 3/8-16 x 1
9	819 13 16-14	Washer 13/32 x 1.0 x 14 Ga.
10	532 18 24-93	Pan Seat
11	532 16 63-69	Knob Seat Adj Wingnut
12	532 12 12-46	Bracket Mounting Switch

KEY NO.	PART NO.	DESCRIPTION
13	532 12 12-48	Bushing Snap Blk Nyl 50 Id
14	872 05 04-12	Bolt Rdhd Sqnk 1/4-20 x 1-1/2
15	532 12 12-49	Spacer Split 28 x .88 Zinc
16	532 12 37-40	Spring Cprsn Plate
17	532 12 39-76	Nut Lock 1/4 Lge Flg Gr. 5 Zinc
21	532 17 18-52	Bolt Shoulder 5/16-18 unc
22	873 80 05-00	Nut Hex Lock W/Ins 5/16-18
24	819 17 19-12	Washer 17/32 x 1-3/16 x 12 Ga.
25	532 12 70-18	Bolt Shoulder 5/16-18 x 62

NOTE: All component dimensions given in U.S. inches.
1 inch = 25.4 mm

REPAIR PARTS

TRACTOR - MODEL NUMBER YTH2148XP (HAU21H48B), PRODUCT NO. 954 17 02-27
DECALS

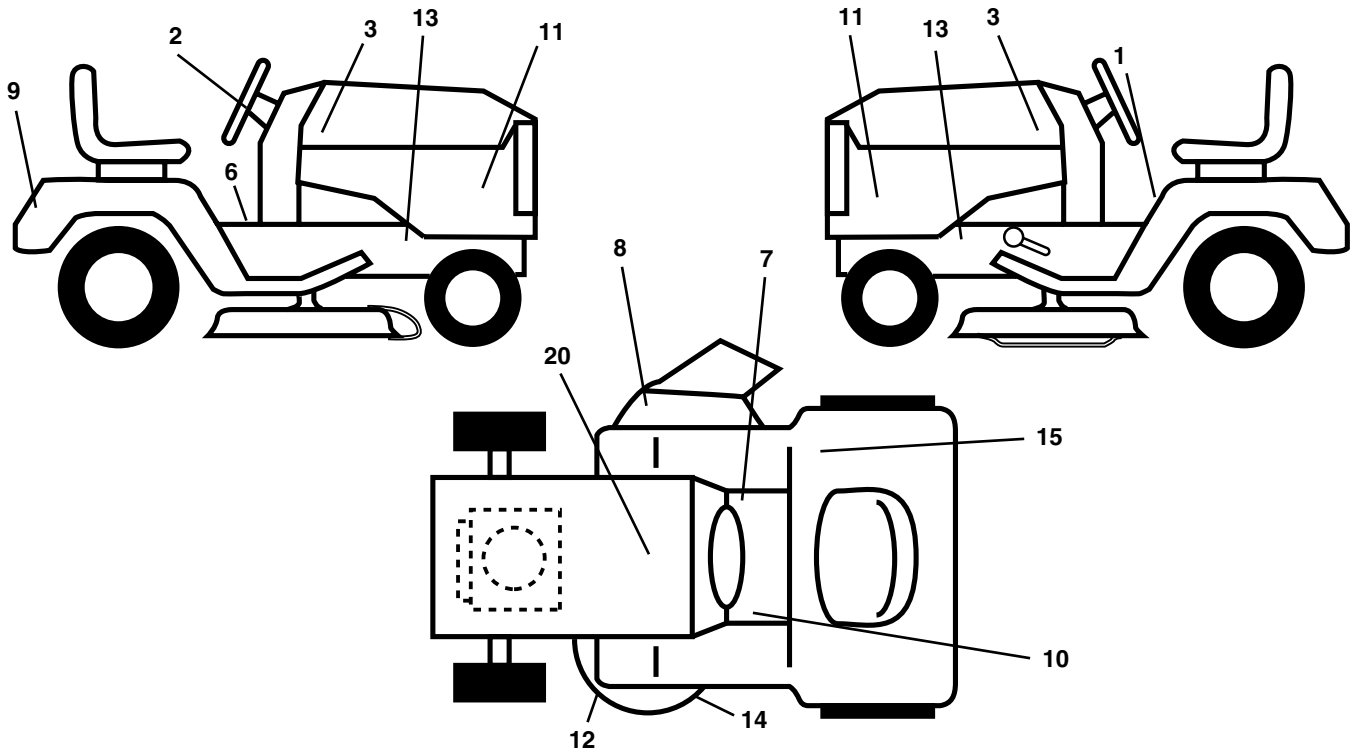

KEY NO.	PART NO.	DESCRIPTION
1	532 14 54-98	Decal Oper Inst Hyd E/F
2	532 18 89-25	Decal Strg Wheel Logo
3	532 18 89-21	Decal Hood
6	532 17 83-02	Decal Cruise
7	532 14 08-37	Decal Brake Parking
8	532 18 21-66	Decal Cut Finger CE
9	532 19 04-10	Decal Fender Husq
10	532 15 97-37	Decal Brake/Clutch Symbol
11	532 19 11-60	Decal Hood Sides
12	532 17 85-02	Decal Clutch/Brake

KEY NO.	PART NO.	DESCRIPTION
13	532 15 97-36	Decal Chassis Hot Muffler
14	532 17 52-91	Decal V-Belt Schematic
15	532 16 88-69	Decal Tick Mark
20	532 14 50-05	Decal Bat Dan/Psn
--	532 16 69-60	Decal By Pass Lt Hydro
--	532 18 14-95	Pad Footrest LH
--	532 18 14-96	Pad Footrest RH
--	532 16 25-98	Decal Draw Bar Load Limit
--	532 19 57-68	Manual Owner's (English)

WHEELS & TIRES

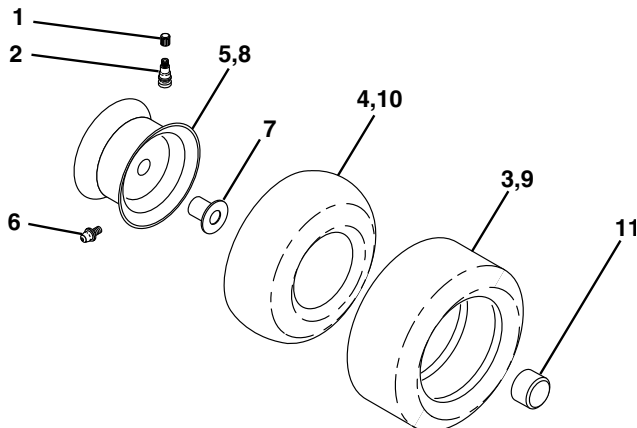

KEY NO.	PART NO.	DESCRIPTION
1	532 05 91-92	Cap Valve Tire
2	532 06 51-39	Stem Valve
3	532 10 62-22	Tire F Ts 15 x 6.0 - 6 Service
4	532 05 99-04	Tube Front (Service Item Only)
5	532 13 83-36	Rim Asm 6" front Silver Service
6	532 12 49-57	Fitting Grease (Front Wheel Only)
7	532 12 49-59	Bearing Flange (Front Wheel Only)
8	532 13 83-37	Rim Asm 8" rear Silver Service
9	532 12 20-82	Tire R Ts 20 x 10-8 C Service
10	532 12 49-26	Tube Rear (Service Item Only)
11	532 17 50-39	Cap Axle Blk 1 50 x 1 00
--	532 14 43-34	Sealant, Tire (10 oz. Tube)

NOTE: All component dimensions given in U.S. inches
1 inch = 25.4 mm

REPAIR PARTS

TRACTOR - MODEL NUMBER YTH2148XP (HAU21H48B), PRODUCT NO. 954 17 02-27

MOWER LIFT

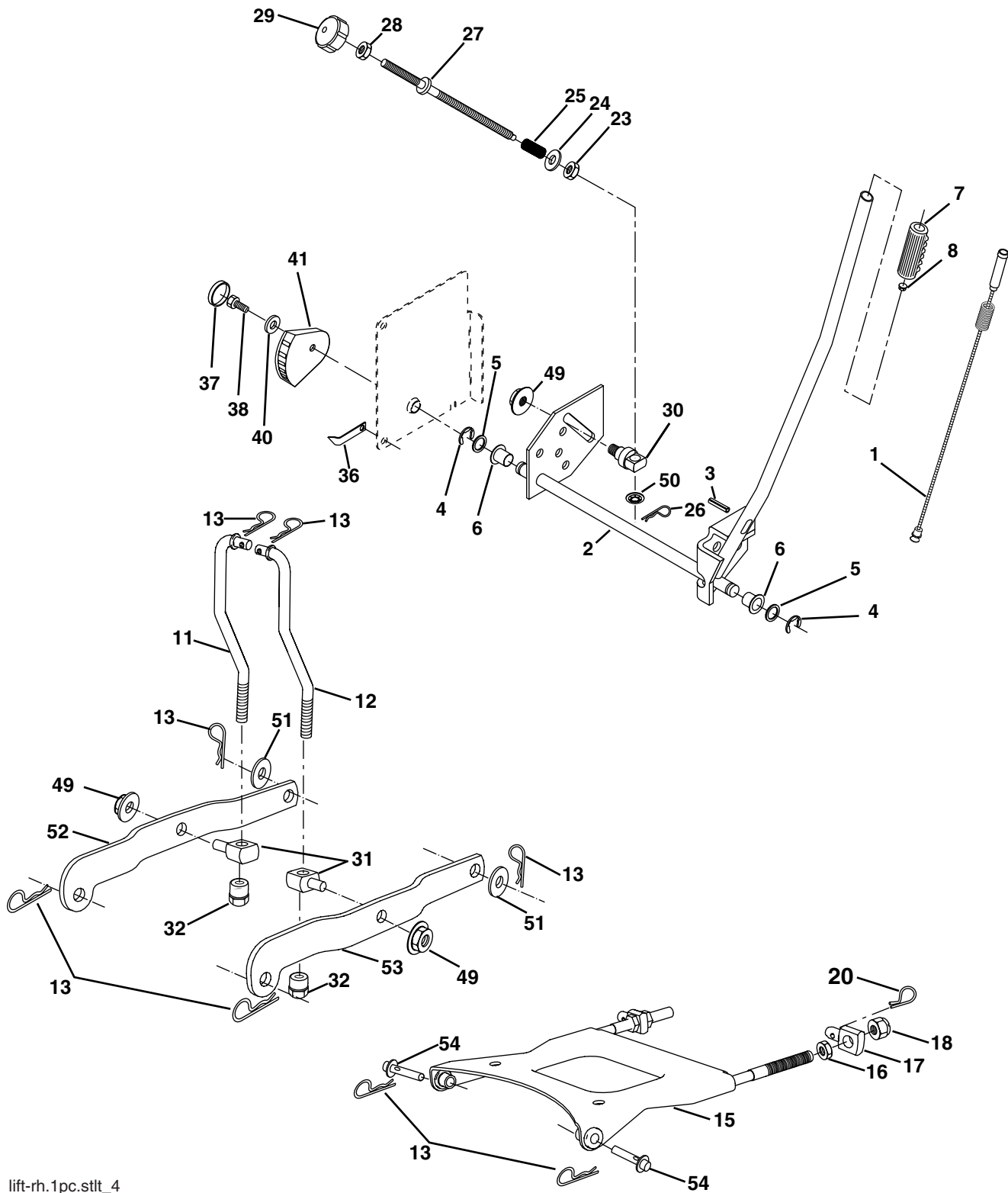

REPAIR PARTS

TRACTOR - MODEL NUMBER YTH2148XP (HAU21H48B), PRODUCT NO. 954 17 02-27
MOWER LIFT

KEY NO.	PART NO.	DESCRIPTION
1	532 15 94-61	Wire Asm Inner/Spring W/Plunger LT
2	532 15 94-76	Shaft Asm Lift RH w/Inf
3	532 18 88-22	Pin Groove
4	812 00 00-02	E Ring #5133-62
5	819 21 16-21	Washer 21/32 x 1 x 21 Ga.
6	532 12 01-83	Bearing Nylon Blk 629 ID
7	532 12 56-31	Grip Handle Fluted Blk
8	532 12 45-26	Button Plunger Black
11	532 17 53-70	Link Lift LH
12	532 17 53-71	Link Lift RH
13	532 12 46-70	Retainer Spring
15	532 17 55-62	Plate Asm Susp Front
16	873 35 08-00	Nut Jam Hex 1/2-13 unc
17	532 17 56-89	Trunnion
18	873 80 08-00	Nut Lock w/Wsh 1/2-13 unc
20	532 16 35-52	Retainer Spring
23	532 11 08-07	Nut Special
24	819 13 10-16	Washer 13/32 x 5/8 x 16 Ga.
25	532 16 40-24	Spring
26	532 16 94-84	Retainer Clip
27	532 16 45-43	Rod Adj Lift
28	873 35 06-00	Nut Hex Jam 3/8-16 unc
29	532 13 80-57	Knob Inf 3/8-16 unc Blk W/sym
30	532 15 02-33	Trunnion Infin Height
31	532 17 62-05	Trunnion
32	532 17 59-94	Nut Lift Link 7/16-20
36	532 15 50-97	Indicator Height STL
37	532 12 39-35	Plug Hole Blk 1.485/1.515 Dia.
38	817 06 05-16	Screw 5/16-18 x 1
40	819 11 24-10	Washer 11/32 x 1-1/2 10 Ga.
41	532 15 50-98	Scale Ind. Height Blk.
49	532 14 52-12	Nut Hex Flange Lock
50	532 11 04-52	Nut, Push Phos & Oil
51	819 17 14-16	Washer 17/32 x 7/8 x 16 Ga.
52	532 17 53-78	Arm Susp. Rear Lh
53	532 17 58-02	Arm Susp. Rear Rh
54	532 17 55-60	Pin Flange

NOTE: All component dimensions given in U.S. inches
1 inch = 25.4 mm

REPAIR PARTS

TRACTOR - MODEL NUMBER YTH2148XP (HAU21H48B), PRODUCT NO. 954 17 02-27

MOWER DECK

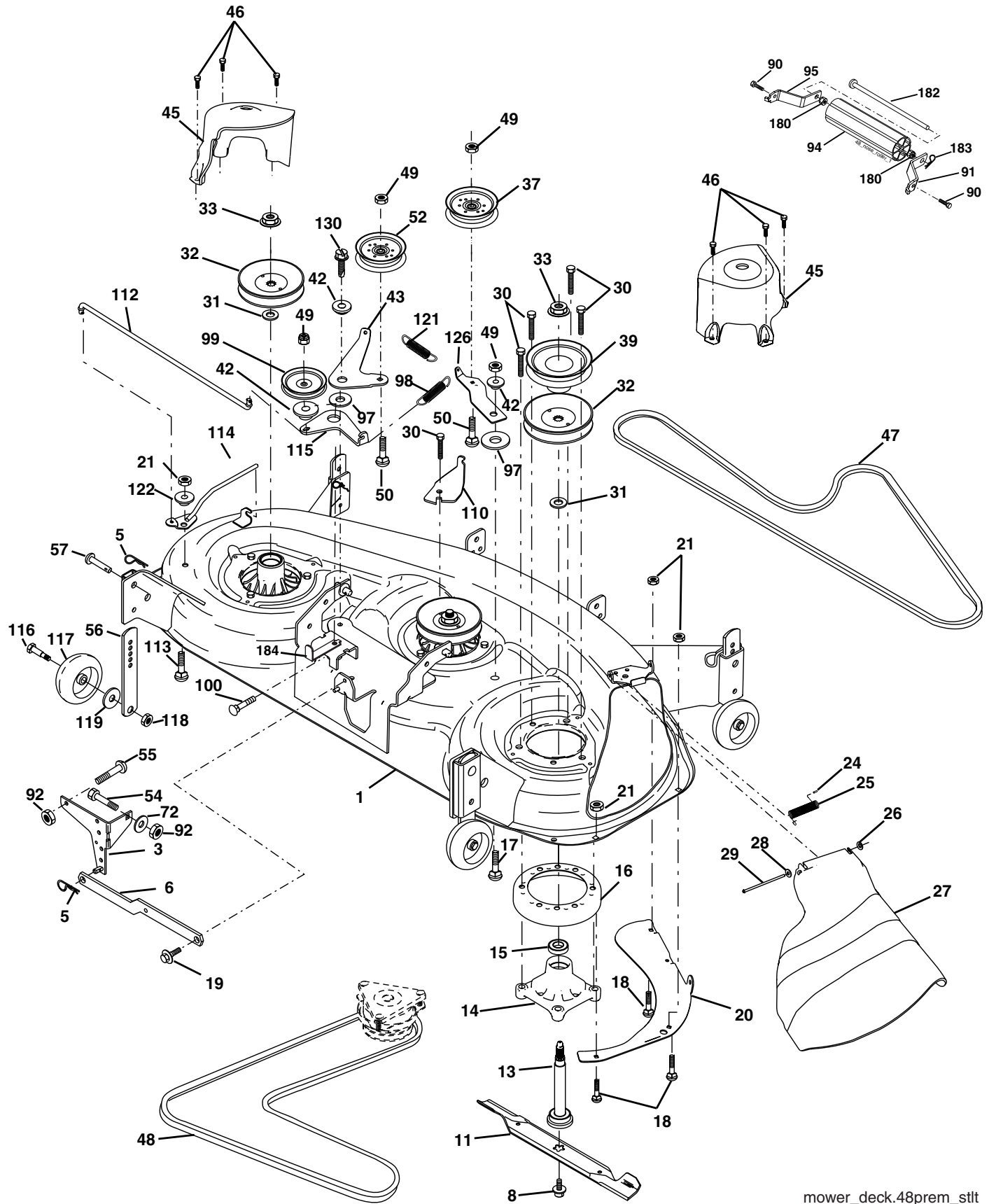

REPAIR PARTS

TRACTOR - MODEL NUMBER YTH2148XP (HAU21H48B), PRODUCT NO. 954 17 02-27
MOWER DECK

KEY NO.	PART NO.	DESCRIPTION	KEY NO.	PART NO.	DESCRIPTION
1	532 18 18-48	Deck Weldment Mower 48	55	872 14 06-08	Bolt Rdhd Sqnk 3/8-16 x 1
3	532 13 80-17	Bracket Asm., Sway Bar	56	532 15 59-86	Bar Pnt Adjusting Wheel Gauge
5	532 12 46-70	Retainer Spring	57	532 15 69-41	Pin Head Rivet
6	532 17 80-24	Sway Bar Deck	72	819 13 13-12	Washer 13/32 x 13/16 x 12
8	532 17 43-65	Bolt, 7/16 Asm. Blade	90	874 76 05-16	Bolt, Fin, Hex 5/16-18 x 1.0
11	532 18 00-54	Blade	91	532 18 05-35	Bracket, Asm Noseroller, RH
13	532 17 43-60	Shaft Asm. greaseable	92	873 80 06-00	Nut Lock Hex w/Ins 3/8-16
14	532 17 43-58	Housing Mandrel 48"	94	532 17 60-66	Roller, Nose 48"
15	532 11 04-85	Bearing, Ball, Mandrel	95	532 18 05-34	Bracket, Asm Noseroller LH
16	532 17 44-93	Stripper, Mower	97	532 17 85-15	Washer Hardened
17	872 11 06-10	Bolt Rdhd Sq Neck 3/8-16 x 1.25	98	532 17 94-79	Spring Primary Drive
18	872 14 05-05	Bolt, Carriage 5/16-18 x 5/8	99	532 18 40-58	Pulley Idler "V"
19	532 13 28-27	Bolt, Hex Head, Shoulder 5/16-18	100	872 11 06-16	Bolt RDHD Sqnk 3/8-16 unc x 2
20	532 17 43-78	Baffle, Vortex Mower	110	532 17 50-16	Arm Spring Secondary
21	873 68 05-00	Nut, Crownlock 5/16-18 unc	112	532 17 43-87	Link Tension Relief Lever
24	532 10 53-04	Cap, Sleeve	113	872 11 05-06	Bolt Rdhd Sqnk 5/16-18 unc x 3/4
25	532 17 81-02	Spring, Torsion	114	532 19 02-58	Tension Asm Relief Lever
26	532 11 04-52	Nut, Push	115	532 17 46-09	Arm Spring Tension Relief
27	532 18 17-07	Shield, Deflector Mower	116	532 19 34-06	Bolt, Shoulder
28	819 11 10-16	Washer 11/32 x 5/8 x 16 Ga.	117	532 17 48-73	Gauge Wheel
29	532 13 14-91	Rod, Hinge	118	873 93 06-00	Nut, Centerlock 3/8-16 unc
30	532 17 39-84	Screw, Thdroll, Washer Head	119	819 12 14-14	Washer 3/8 x 7/8 x 14 Ga.
31	532 18 76-90	Washer, Spacer	121	532 17 43-71	Spring Secondary Drive
32	532 17 78-65	Pulley, Mandrel	122	532 17 46-06	Bushing Pivot Tension Relief
33	532 17 83-42	Nut, Flg. Top Lock Cntr. 9/16	126	532 17 43-72	Arm, Idler, Primary Deck
36	819 13 13-16	Washer 13/32 x 13/16 x 16 Ga.	130	817 00 06-16	Screw 3/8-16 x 1.0
37	532 17 79-68	Pulley, Idler, Flat	180	873 80 05-00	Nut 5/16-18
39	532 17 43-75	Pulley, Idler, Driven	182	532 17 91-27	Rod Roller Nose
42	532 12 20-52	Spacer, Retainer	183	532 16 35-52	Retainer Spring
43	532 17 43-73	Arm, Idler Secondary	184	532 17 39-79	Keeper Belt Idler
45	532 18 08-06	Cover, Mandrel Deck	--	532 17 43-56	Mandrel Assembly Service
46	532 13 77-29	Screw, Thdroll. 1/4-20 x 5/8	--	532 18 15-91	Replacement Mower, Complete (Nose Roller components, 90, 91, 94, 95, 180, 182 and 183, not included)
47	532 18 08-08	V-Belt, Mower, Secondary			
48	532 17 43-68	V-Belt, Mower, Primary			
49	873 90-06-00	Nut, Lock 3/8-16 unc			
50	872 11 06-12	Bolt, Carriage 3/8-16 x 1-1/2 Gr. 5			
52	532 17 58-20	Pulley Idler Flat 46 Pri. Drive			
54	874 78 06-16	Bolt Fin Hex 3/8-16 x 1			

NOTE: All component dimensions given in U.S. inches
1 inch = 25.4 mm