

T25-6

Spare parts
Ersatzteile
Pièces détachées
Reserve onderdelen
Repuestos
Reservdelar

REPAIR PARTS

TILLER - MODEL NO. T 25-6, PRODUCT NO. 106 23 12-80

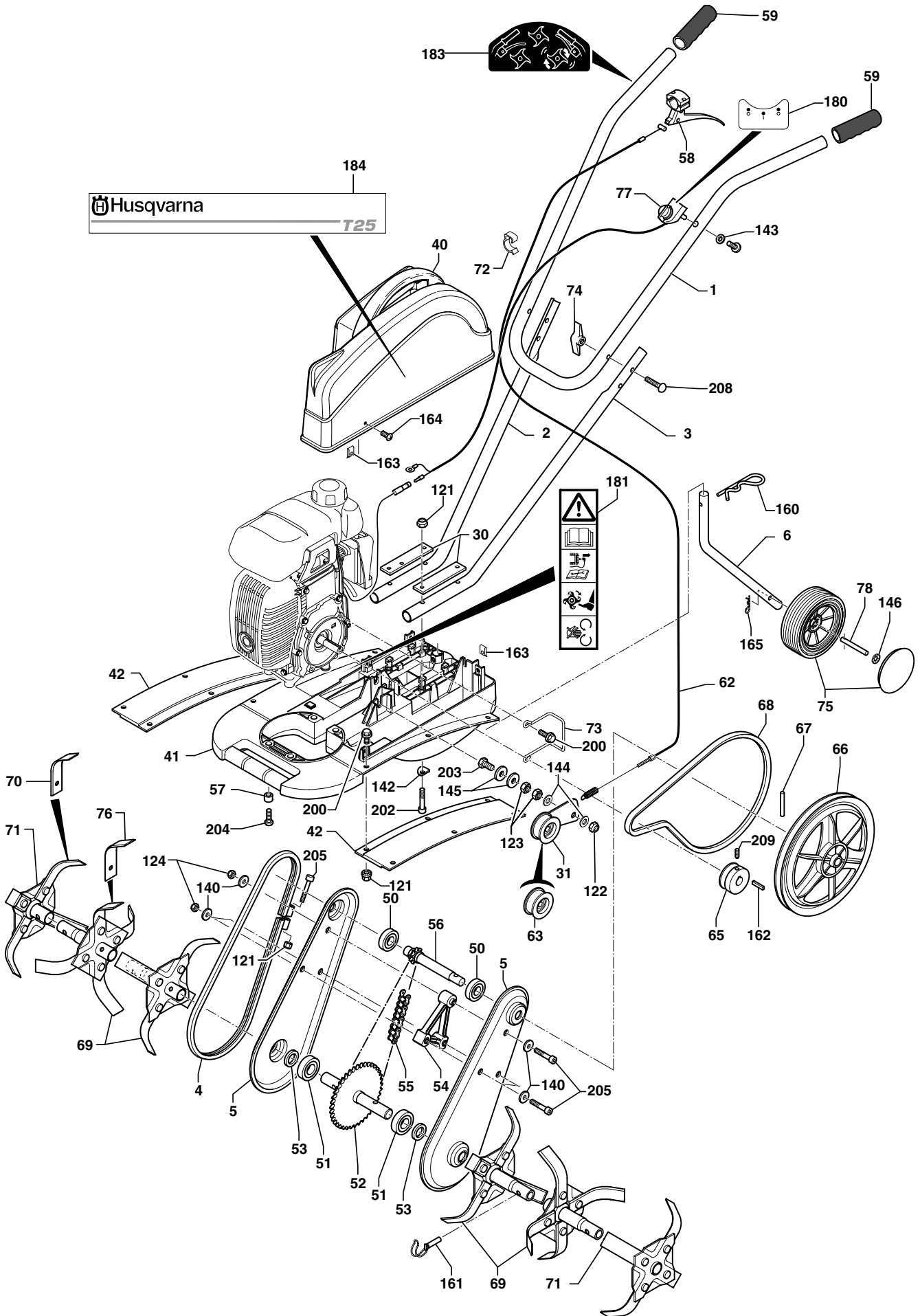

REPAIR PARTS

TILLER - MODEL NO. T 25-6, PRODUCT NO. 106 23 12-80

KEY NO.	PART NO.	DESCRIPTION	DÉSIGNATION	QTY QTÉ
	531 00 84-31	Complete casing, flanged (Black)	Carter complet à jonc (Noir)	
1	531 00 84-32	Black handlebars (top part)(GXH 50)	Guidon noir (partie haute)(GXH 50)	1
2	531 00 84-33	Black handlebars (bottom right-hand part)	Guidon noir (partie droite basse)	1
3	531 00 84-34	Black handlebars (bottom left-hand part)	Guidon noir (partie gauche basse)	1
4	531 00 84-35	Flange (Black)	Jonc (Noir)	1
5	531 00 84-36	Transmission housing (Black)	Joue carter (Noir)	2
6	531 00 84-37	Spur (Black)	Éperon (Noir)	1
30	531 00 84-40	Handlebar fixing plate	Platine fixation guidon	2
31	531 00 84-41	Clutch lever	Levier embrayage	1
40	531 00 84-44	Belt cowl (Orange)	Capot courroie (Orange)	1
41	531 00 84-45	Chassis (Black)	Châssis (Noir)	1
42	531 00 84-46	Guard (black)	Protection (Noir)	2
50	531 00 84-47	Ball-race	Roulement	2
51	519 65 31-90	Ball-race	Roulement	2
52	531 00 84-48	Blade shaft	Arbre de travail	1
53	531 00 84-49	Joint	Joint feutre carter	2
54	531 00 84-50	Spacer	Entretoise plastique	1
55	531 00 84-51	Chain	Chaîne	1
56	531 00 84-52	Primary shaft	Arbre primaire	1
57	531 00 84-53	Spacer	Entretoise fixation moteur	4
58	531 00 85-68	Handle	Manette	1
59	531 00 84-54	Grip	Poignée PVC	2
62	531 00 84-55	Clutch cable	Câble embrayage	1
63	519 65 34-57	Runner	Galet embrayage	1
65	531 00 84-56	Motor pulley Forward gear (Shaft Ø15)	Poulie moteur Mav arbre Ø15	1
66	519 65 30-60	Transmission pulley	Poulie transmission	1
67	519 65 30-67	Pulley shaft	Axe fixation poulie	1
68	531 00 84-57	Forward gear belt	Courroie Mav	1
69	531 00 84-58	Starter blade 30x3 Ø240	Fraise départ 30x3 Ø240	
70	531 00 84-59	Internal bevelled cutter	Couteau biseau intérieur pli	
71	531 00 84-60	Disk blade 30x3 Ø240	Fraise disque. 30x3 Ø240	
72	519 00 64-17	Collar	Collier	2
73	531 00 84-61	Drive-belt guide Forward gear (GXH 50)	Guide courroie M.av (GXH 50)	1
74	531 00 84-62	Handlebar tightening lever	Poignée de serrage guidon	2
75	531 00 85-69	Transport wheel	Roue transport	1
76	531 00 85-63	External bevelled cutter	couteau biseau extérieur pli	
77	531 00 85-58	Switch engine cut-off	Switch arrêt moteur	1
78	531 00 85-62	Axle of travelling wheel	Axe roue de transport	1
121	732 26 16-01	Blocking nut M6 Z	Écrou frein M6 Z	
122	519 65 34-58	Blocking nut M10 Z	Écrou frein M10 Z	
123	519 65 34-56	Nut H M10 Z	Écrou H M10 Z	
124	519 65 34-32	Nut HM6 Z, notched shoulder	Écrou H M6 Z embase crantée	
140	531 00 83-90	Washer 6,3x19x2,5 Z	Rondelle 6,3x19x2,5 Z	
141	519 65 34-62	Starlock washer 10	Rondelle Starlock 10	
142	531 00 84-65	"6" shaped washer, 22mm diam.	Rondelle 6 forme Ø22	
143	531 00 85-39	Washer 3x10x1 Z	Rondelle 3x10x1 Z	
144	734 11 72-01	Washer 10x22x2 Z	Rondelle 10x22x2 Z	
145	531 00 84-66	Washer 10x27x2 Z	Rondelle 10x27x2 Z	
146	519 00 28-60	Starlock washer 8	Rondelle Starlock 8	
160	531 00 84-67	Clip pin Bêta 5 Z	Goupille Bêta 5 Z	
161	531 00 84-68	Clip pin, Ø8 x 28	Goupille clips Ø8 x 28	
162	531 00 83-95	Key (Shaft Ø15)	Clavette arbre Ø15	
163	519 65 34-25	Spire nuts 4,2	Clips 4,2	
164	519 65 34-26	Cover bolt 4,2	Vis Tôle 4,2	
165	519 65 12-20	Clip pin Bêta 2 Z	Goupille Bêta 2 Z	
180	519 65 31-03	Label: "engine cut-off "	Étiq. "Arrêt moteur"	
181	531 00 85-40	Safety label	Étiq. "Sécurité"	
183	519 65 30-85	Label: clutch lever	Étiquette embrayage	
184	531 00 94-08	Label: husqvarna T25	Étiq.: husqvarna T25	
200	519 65 34-35	Screw H M6x16 Z, notched shoulder	Vis H M6x16 Z embase crantée	
202	519 65 31-13	Screw H M6x60 Z	Vis H M6x60 Z	
203	531 00 84-70	Screw H M10x45 Z	Vis H M10x45 Z	

REPAIR PARTS

TILLER - MODEL NO. T 25-6, PRODUCT NO. 106 23 12-80

KEY NO.	PART NO.	DESCRIPTION	DÉSIGNATION	QTY QTÉ
204	531 00 84-71	Screw H M6x20 Z, notched shoulder	Vis H M6x20 Z embase crantée	
205	519 65 30-10	Screw CHc M6x50	Vis CHc M6x50	
208	531 00 84-73	Screw M8x40 forged head bolt	Vis M8x40 tête emboutie	
209	519 65 30-20	Screw St Hc M8x16 N	Vis St Hc M8x16 N	

REPAIR PARTS

TILLER - MODEL NO. T 25-6, PRODUCT NO. 106 23 12-80

KEY NO.	PART NO.	DESCRIPTION	DÉSIGNATION	QTÉ QTY	
	531 00 84-31	18501500	Complete casing, flanged (Black)	Carter complet à jonc (Noir)	
1	531 00 84-32	18501108	Black handlebars (top part)(GXH 50)	Guidon noir (partie haute)(GXH 50)	1
2	531 00 84-33	18501106	Black handlebars (bottom right-hand part)	Guidon noir (partie droite basse)	1
3	531 00 84-34	18501107	Black handlebars (bottom left-hand part)	Guidon noir (partie gauche basse)	1
4	531 00 84-35	18501132	Flange (Black)	Jonc (Noir)	1
5	531 00 84-36	18501130	Transmission housing (Black)	Joue carter (Noir)	2
6	531 00 84-37	18501104	Spur (Black)	Éperon (Noir)	1
30	531 00 84-40	18501109	Handlebar fixing plate	Platine fixation guidon	2
31	531 00 84-41	18501240	Clutch lever	Levier embrayage	1
40	531 00 84-44	18509525	Belt cowl (Orange)	Capot courroie (Orange)	1
41	531 00 84-45	18501505	Chassis (Black)	Châssis (Noir)	1
42	531 00 84-46	14139	Guard (black)	Protection (Noir)	2
50	531 00 84-47	12520	Ball-race	Roulement	2
51	519 65 31-90	12517	Ball-race	Roulement	2
52	531 00 84-48	15036	Blade shaft	Arbre de travail	1
53	531 00 84-49	12331	Joint	Joint feutre carter	2
54	531 00 84-50	14141	Spacer	Entretoise plastique	1
55	531 00 84-51	13288	Chain	Chaîne	1
56	531 00 84-52	15033	Primary shaft	Arbre primaire	1
57	531 00 84-53	16040	Spacer	Entretoise fixation moteur	4
58	531 00 85-68	62756	Handle	Manette	1
59	531 00 84-54	12151	Grip	Poignée PVC	2
62	531 00 84-55	13263	Clutch cable	Câble embrayage	1
63	519 65 34-57	12162	Runner	Galet embrayage	1
65	531 00 84-56	15360	Motor pulley Forward gear (Shaft Ø15)	Poulie moteur Mav arbre Ø15	1
66	519 65 30-60	14135	Transmission pulley	Poulie transmission	1
67	519 65 30-67	15098	Pulley shaft	Axe fixation poulie	1
68	531 00 84-57	13604	Forward gear belt	Courroie Mav	1
69	531 00 84-58	55125a	Starter blade 30x3 Ø240	Fraise départ 30x3 Ø240	
70	531 00 84-59	81919a	Internal bevelled cutter	Couteau biseau intérieur pli	
71	531 00 84-60	55126a	Disk blade 30x3 Ø240	Fraise disque. 30x3 Ø240	
72	519 00 64-17	64349	Collar	Collier	2
73	531 00 84-61	14986	Drive-belt guide Forward gear (GXH 50)	Guide courroie M.av (GXH 50)	1
74	531 00 84-62	12152	Handlebar tightening lever	Poignée de serrage guidon	2
75	531 00 85-69	14261	Transport wheel	Roue transport	1
76	531 00 85-63	81920a	External bevelled cutter	couteau biseau extérieur pli	
77	531 00 85-58	13210	Switch engine cut-off	Switch arrêt moteur	1
78	531 00 85-62	15530	Axle of travelling wheel	Axe roue de transport	1
121	732 26 16-01	11482	Blocking nut M6 Z	Écrou frein M6 Z	
122	519 65 34-58	11485	Blocking nut M10 Z	Écrou frein M10 Z	
123	519 65 34-56	11429	Nut H M10 Z	Écrou H M10 Z	
124	519 65 34-32	11518	Nut HM6 Z, notched shoulder	Écrou H M6 Z embase crantée	
140	531 00 83-90	11647	Washer 6,3x19x2,5 Z	Rondelle 6,3x19x2,5 Z	
141	519 65 34-62	11818	Starlock washer 10	Rondelle Starlock 10	
142	531 00 84-65	11646	"6" shaped washer, 22mm diam.	Rondelle 6 forme Ø22	
143	531 00 85-39	11611	Washer 3x10x1 Z	Rondelle 3x10x1 Z	
144	734 11 72-01	11621	Washer 10x22x2 Z	Rondelle 10x22x2 Z	
145	531 00 84-66	11622	Washer 10x27x2 Z	Rondelle 10x27x2 Z	
146	519 00 28-60	11820	Starlock washer 8	Rondelle Starlock 8	
160	531 00 84-67	11705	Clip pin Bêta 5 Z	Goupille Bêta 5 Z	
161	531 00 84-68	55086	Clip pin, Ø8 x 28	Goupille clips Ø8 x 28	
162	531 00 83-95	12971	Key (Shaft Ø15)	Clavette arbre Ø15	
163	519 65 34-25	11495	Spire nuts 4,2	Clips 4,2	
164	519 65 34-26	11135	Cover bolt 4,2	Vis Tôle 4,2	
165	519 65 12-20	11702	Clip pin Bêta 2 Z	Goupille Bêta 2 Z	
180	519 65 31-03	14678a	Label: "engine cut-off "	Étiq. "Arrêt moteur"	
181	531 00 85-40	21240	Safety label	Étiq. "Sécurité"	
183	519 65 30-85	62831a	Label: clutch lever	Étiquette embrayage	
184	531 00 94-08	21214	Label: husqvarna T25	Étiq.: husqvarna T25	
200	519 65 34-35	11250	Screw H M6x16 Z, notched shoulder	Vis H M6x16 Z embase crantée	
202	519 65 31-13	10749	Screw H M6x60 Z	Vis H M6x60 Z	
203	531 00 84-70	10814	Screw H M10x45 Z	Vis H M10x45 Z	
204	531 00 84-71	11251	Screw H M6x20 Z, notched shoulder	Vis H M6x20 Z embase crantée	
205	519 65 30-10	11061	Screw CHc M6x50	Vis CHc M6x50	

REPAIR PARTS

TILLER - MODEL NO. T 25-6, PRODUCT NO. 106 23 12-80

KEY NO.	PART NO.	DESCRIPTION	DÉSIGNATION	QTÉ QTY
208	531 00 84-73	11355	Screw M8x40 forged head bolt	Vis M8x40 tête emboutie
209	519 65 30-20	11085	Screw St Hc M8x16 N	Vis St Hc M8x16 N