

Parts manual  
BZ6127TD/968999262  
BZ7234TD/968999264

Please read the operator's manual carefully and make sure you understand the instructions before using the machine.

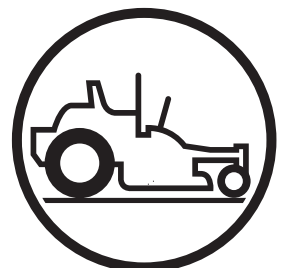

English



# TABLE OF CONTENTS

---

	<u>PAGE</u>
MAIN FRAME ASSEMBLY .....	4
ENGINE ASSEMBLY, 27 H.P. ....	6
ENGINE ASSEMBLY, 34 H.P. ....	8
RADIATOR, 27 H.P. ....	10
RADIATOR, 34 H.P. ....	11
MOTION CONTROL.....	12
HYDRAULIC HOSES & FITTINGS .....	13
HYDRAULIC ASSEMBLY .....	14
FUEL GROUP .....	16
BRAKE GROUP LINKAGE .....	18
SEAT ASSEMBLY .....	20
FOOT PEDAL .....	21
CASTER ASSEMBLY .....	22
DECK LIFT (MANUAL).....	23
DECK LIFT (POWER) .....	24
DECK ASSEMBLY, 61" .....	26
DECK ASSEMBLY, 72" .....	28
DECALS .....	30
ELECTRICAL GROUP .....	31
WIRE HARNESS .....	32
WIRING SCHEMATIC .....	34
ROPS (ROLL OVER PROTECTION SYSTEM) .....	36
ACCESSORIES .....	37
61" MULCH KIT .....	37
72" MULCH KIT .....	38
61" BAFFLE KIT .....	39
72" BAFFLE KIT .....	40
PARTS DESCRIPTIONS .....	41

# MAIN FRAME ASSEMBLY

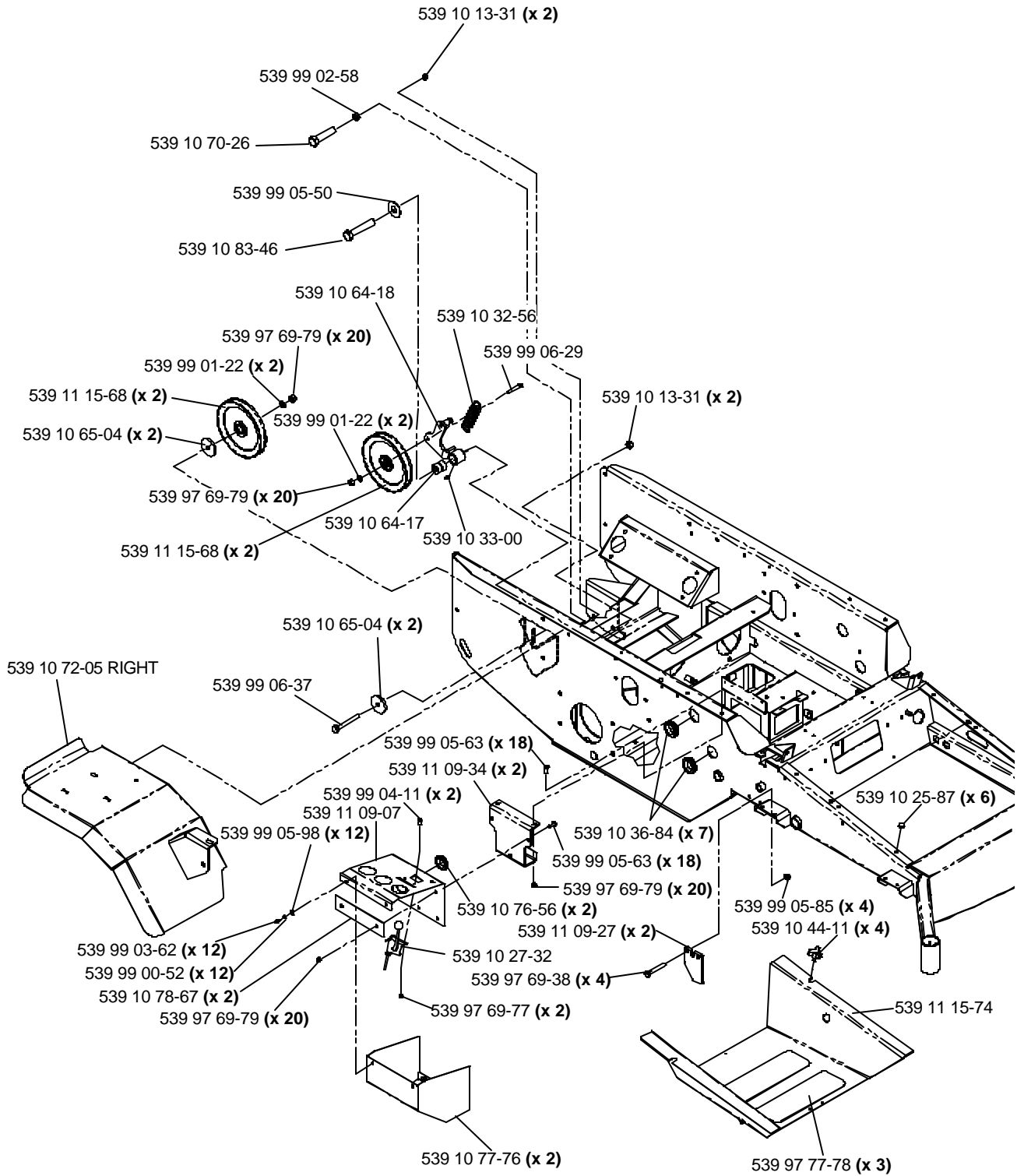

# MAIN FRAME ASSEMBLY

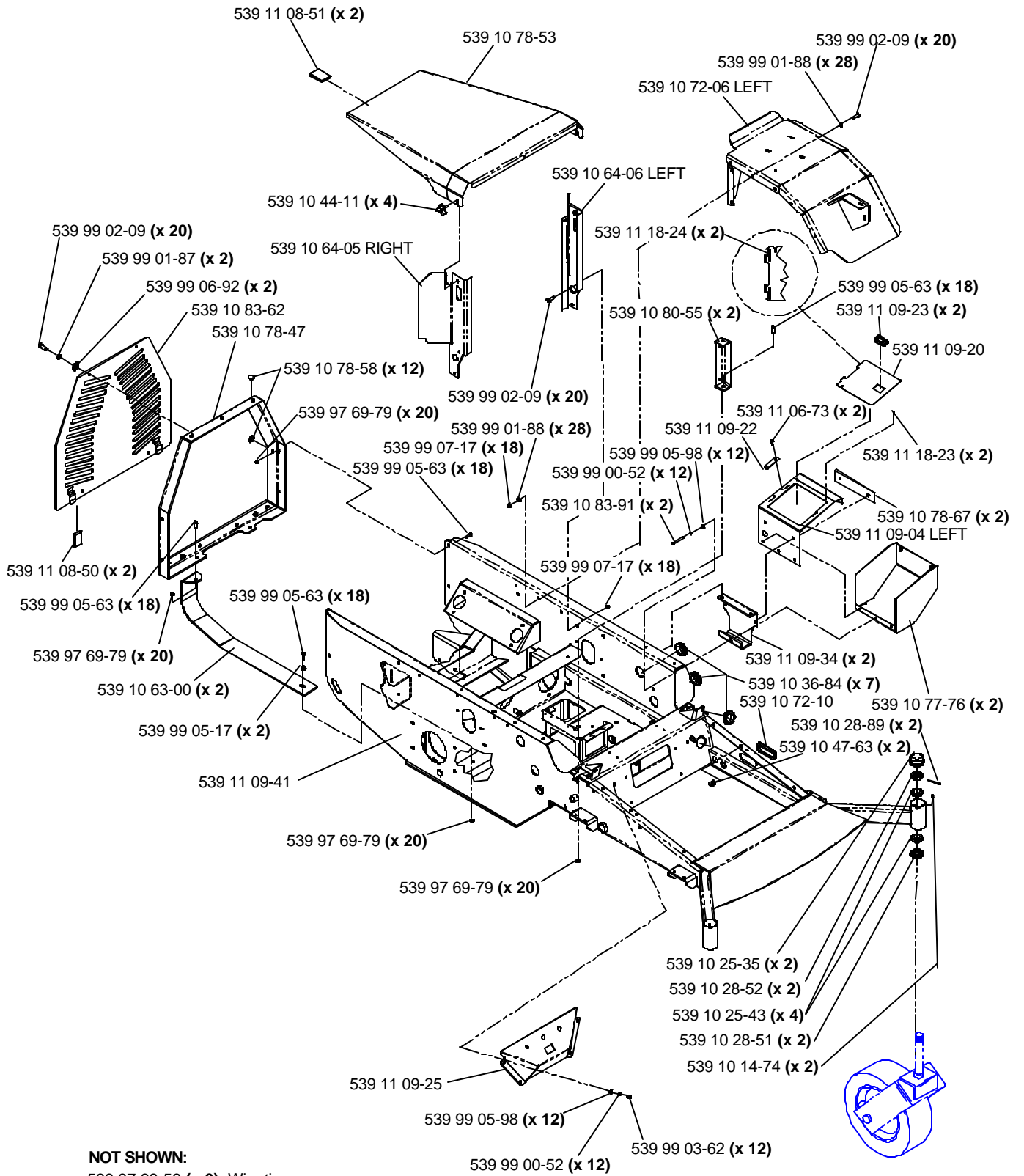

# ENGINE ASSEMBLY

**27 H.P.**

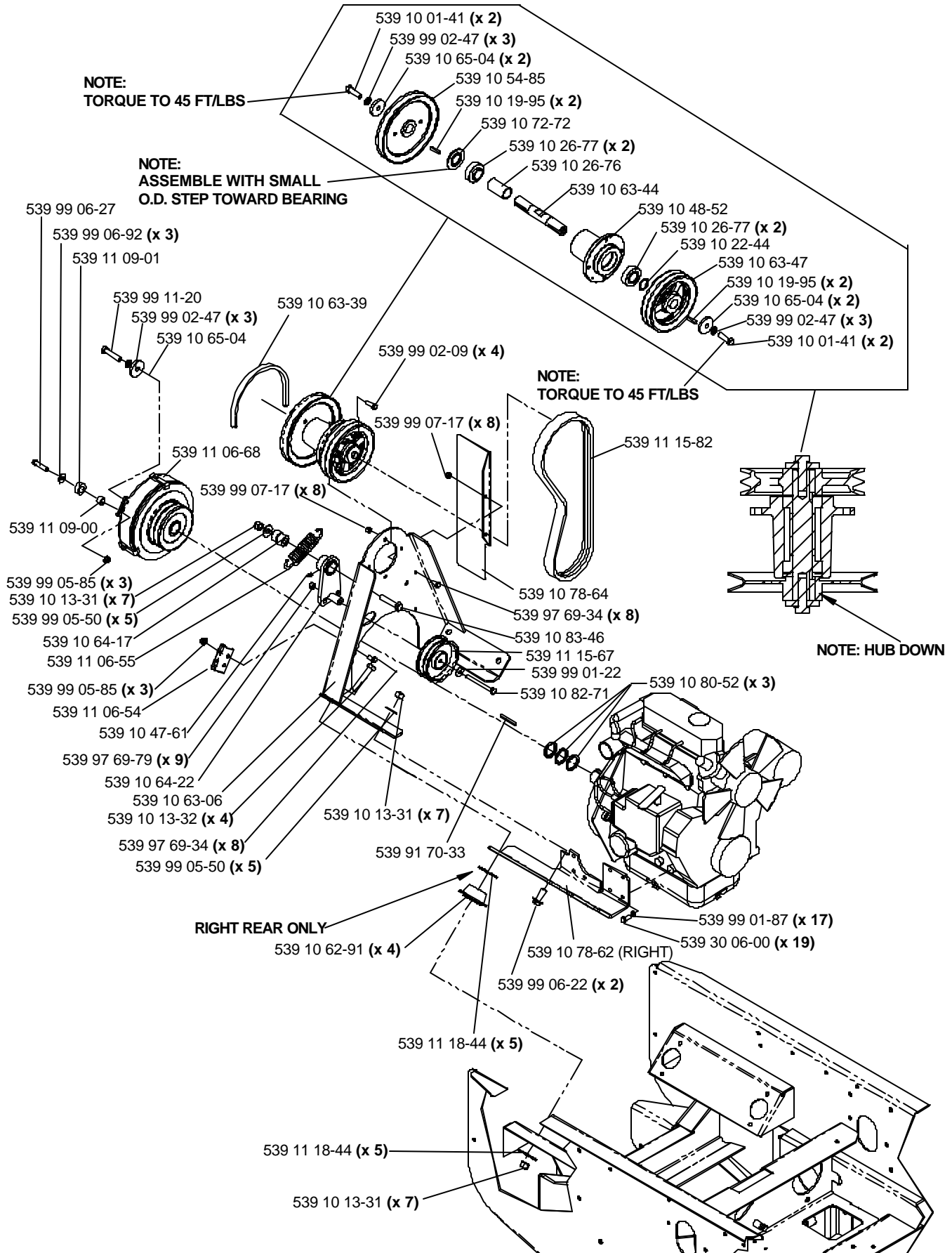

# ENGINE ASSEMBLY

27 H.P.

**NOT SHOWN:**

- 539 10 63-27 Stub shaft
- 539 10 91-77 Manifold gasket

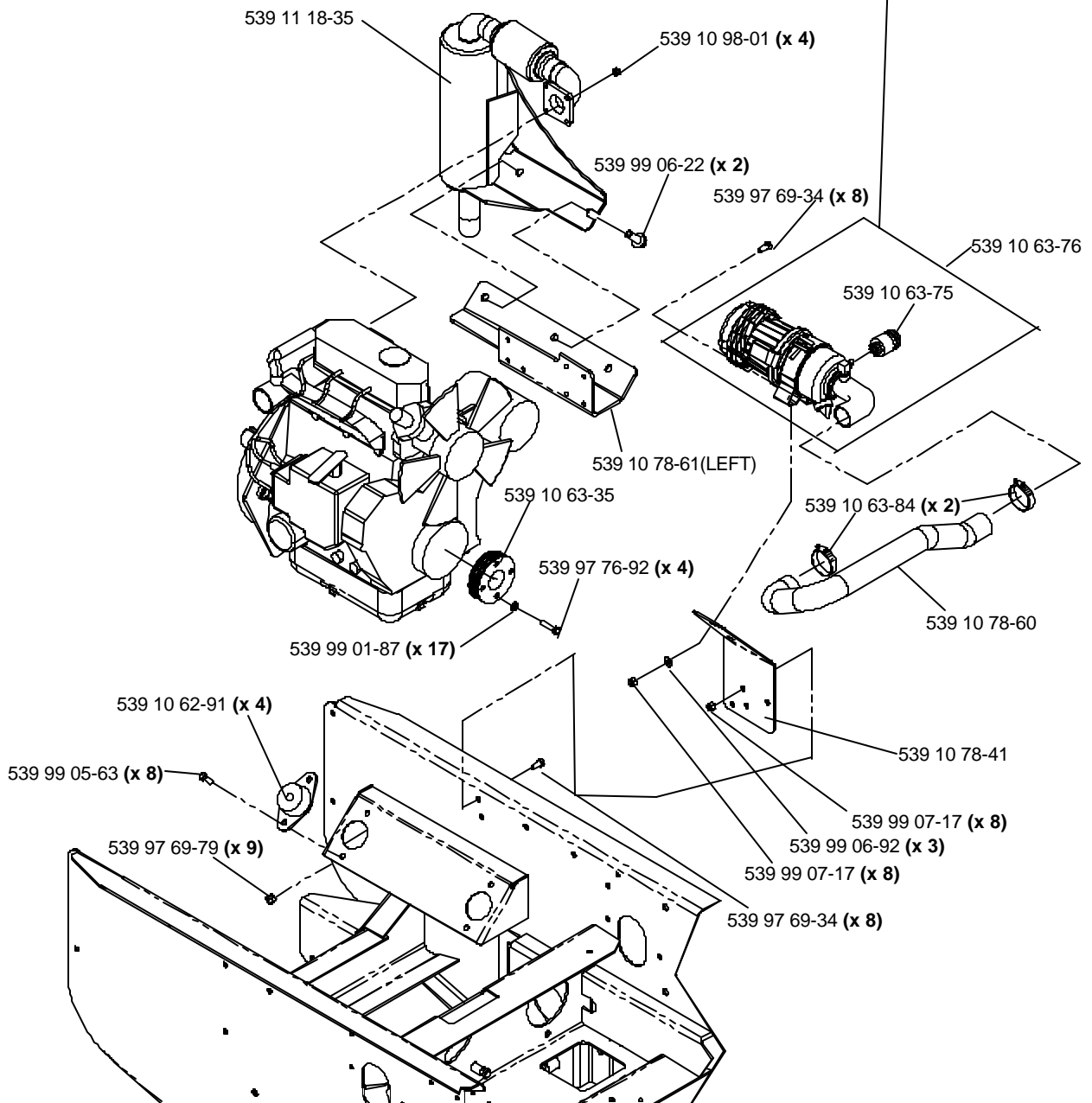
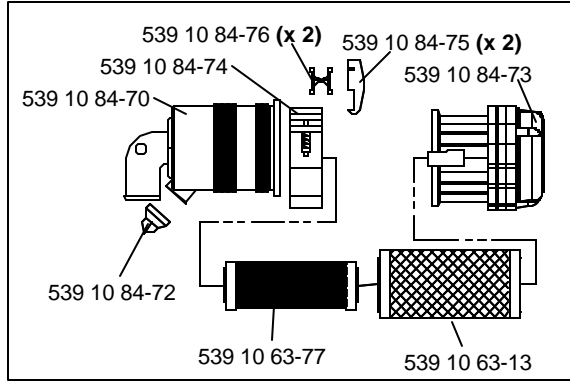

# ENGINE ASSEMBLY

34 H.P.

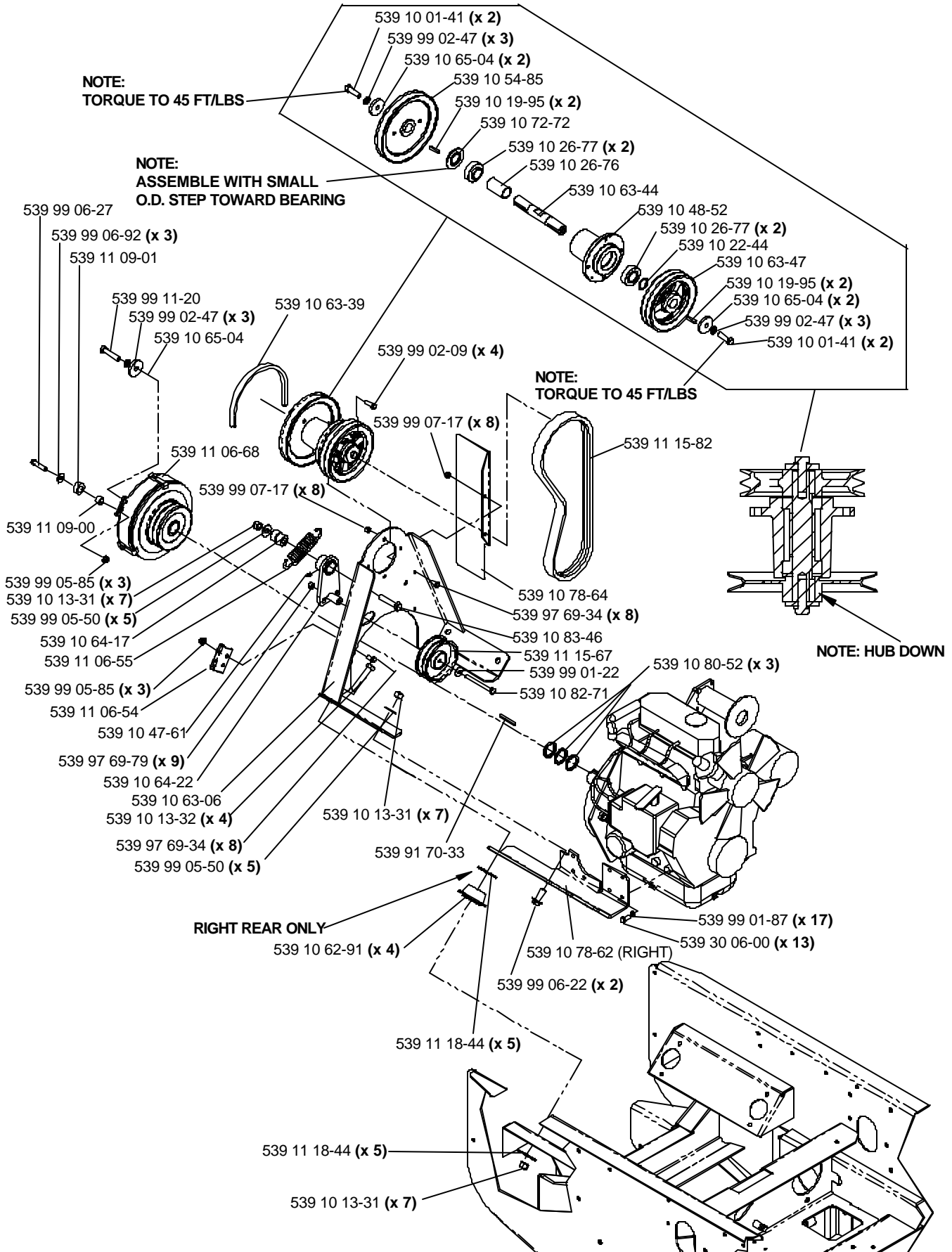



# ENGINE ASSEMBLY

34 H.P.

**NOT SHOWN:**

539 10 63-27 Stub shaft

539 10 91-77 Manifold gasket

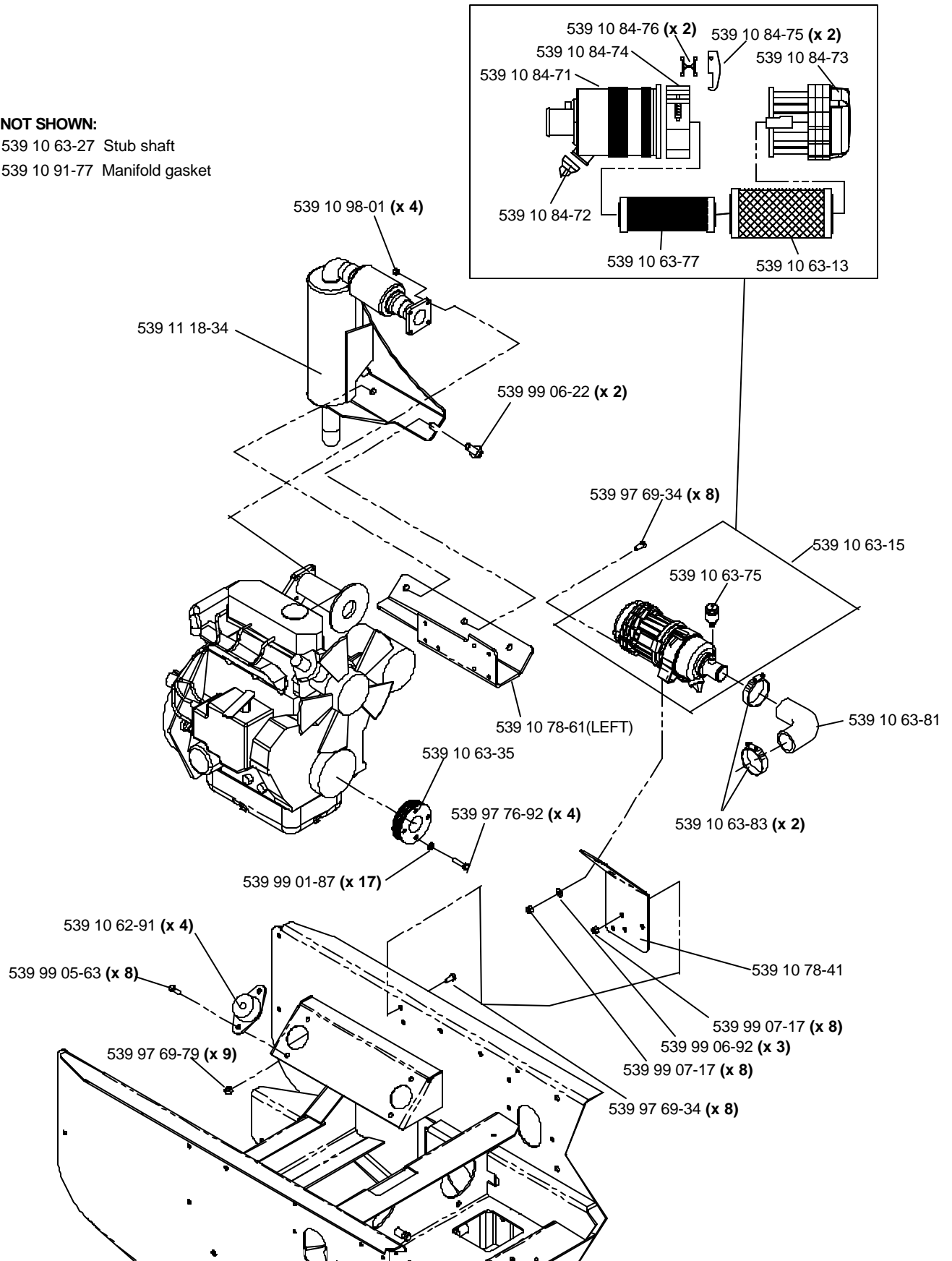





# MOTION CONTROL

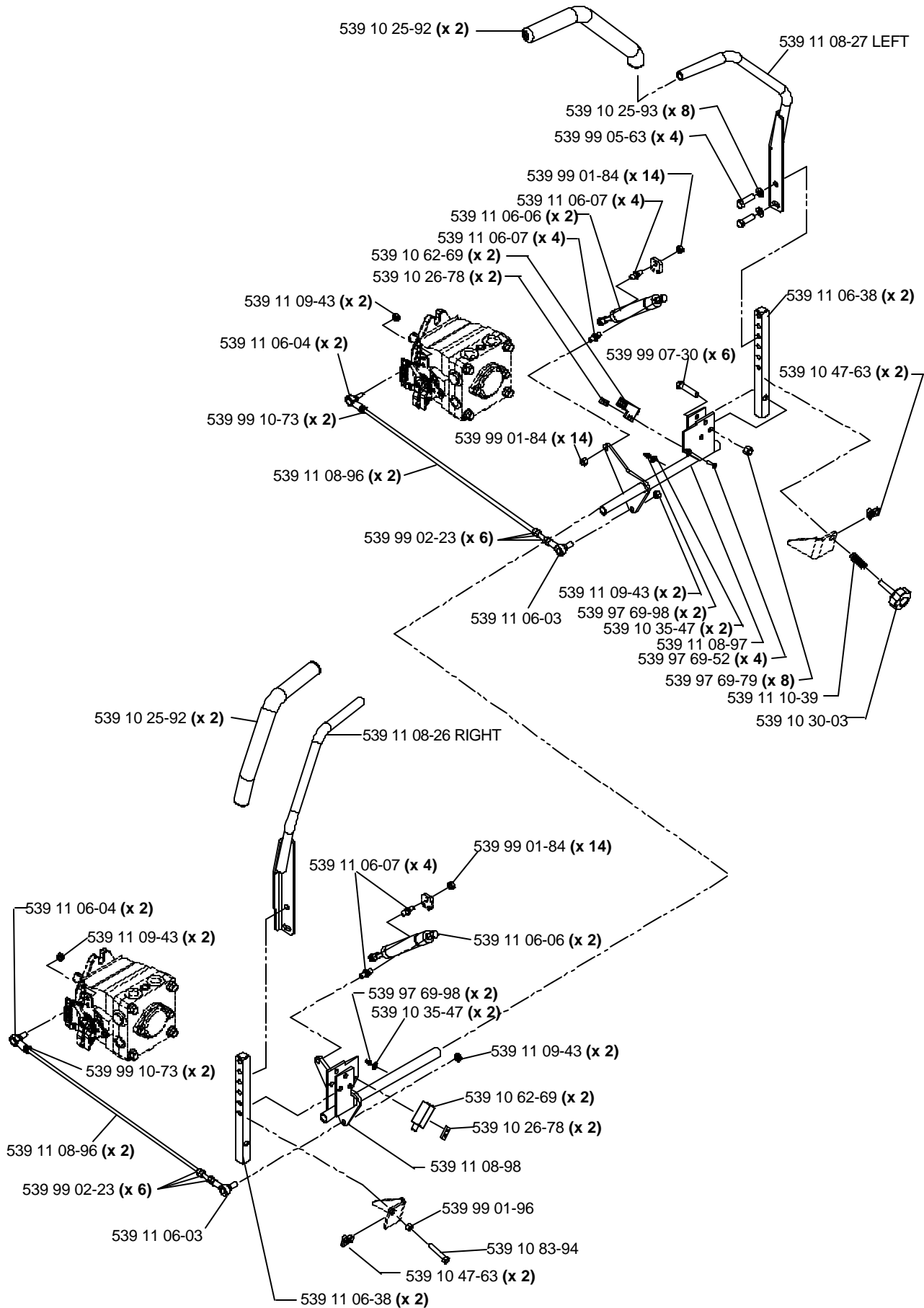

# HYDRAULIC HOSES AND FITTINGS

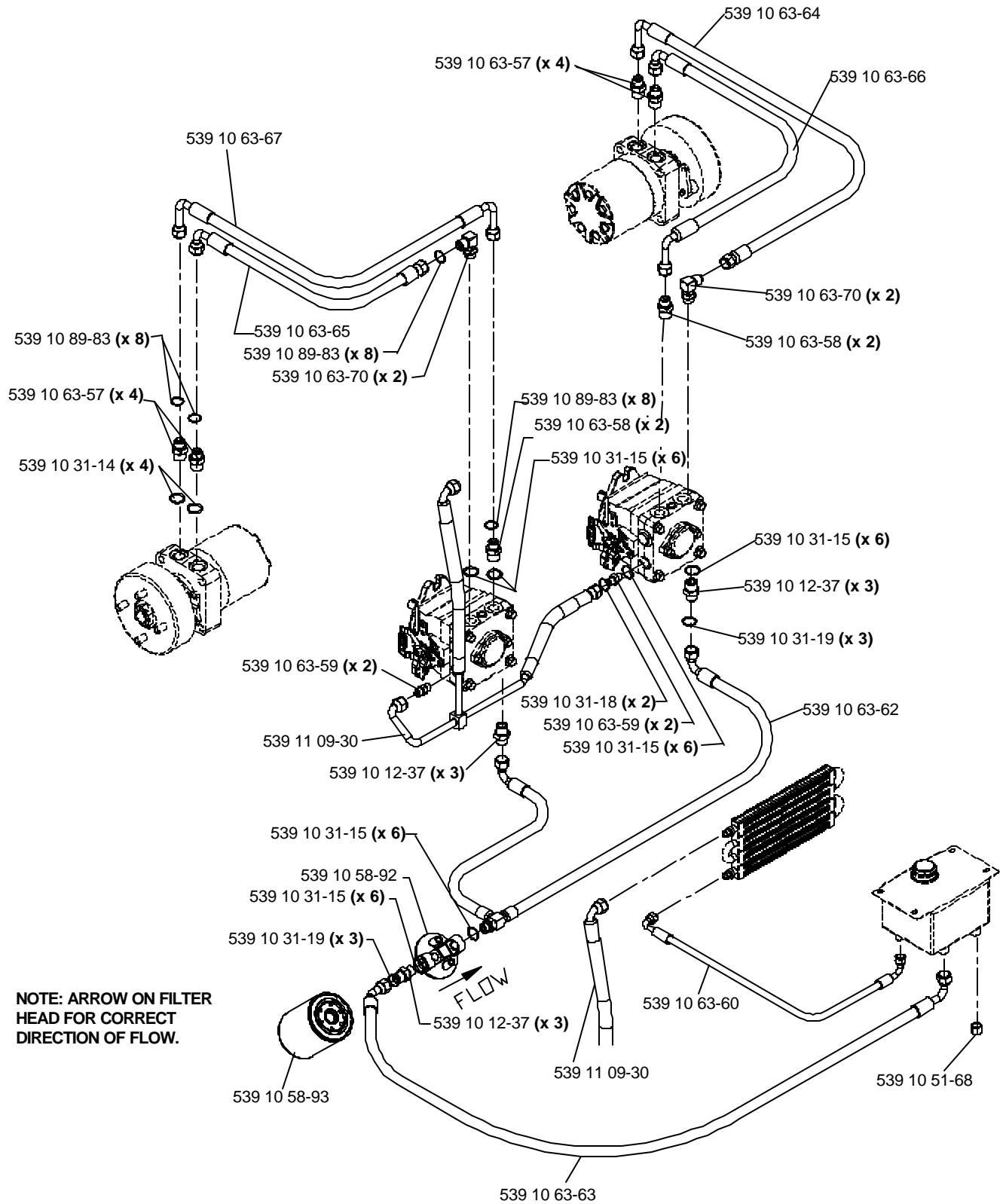

# HYDRAULIC ASSEMBLY

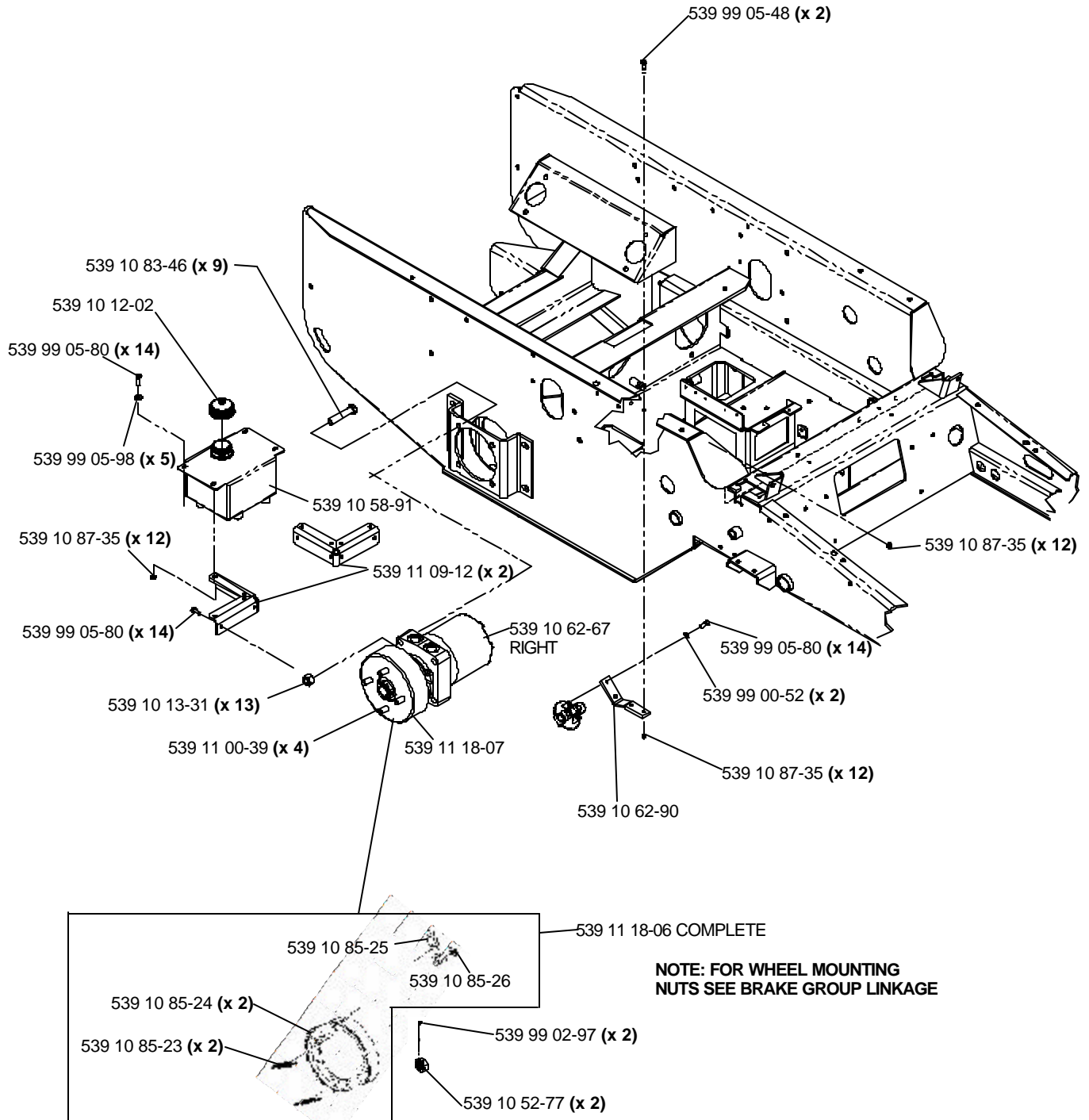

# HYDRAULIC ASSEMBLY

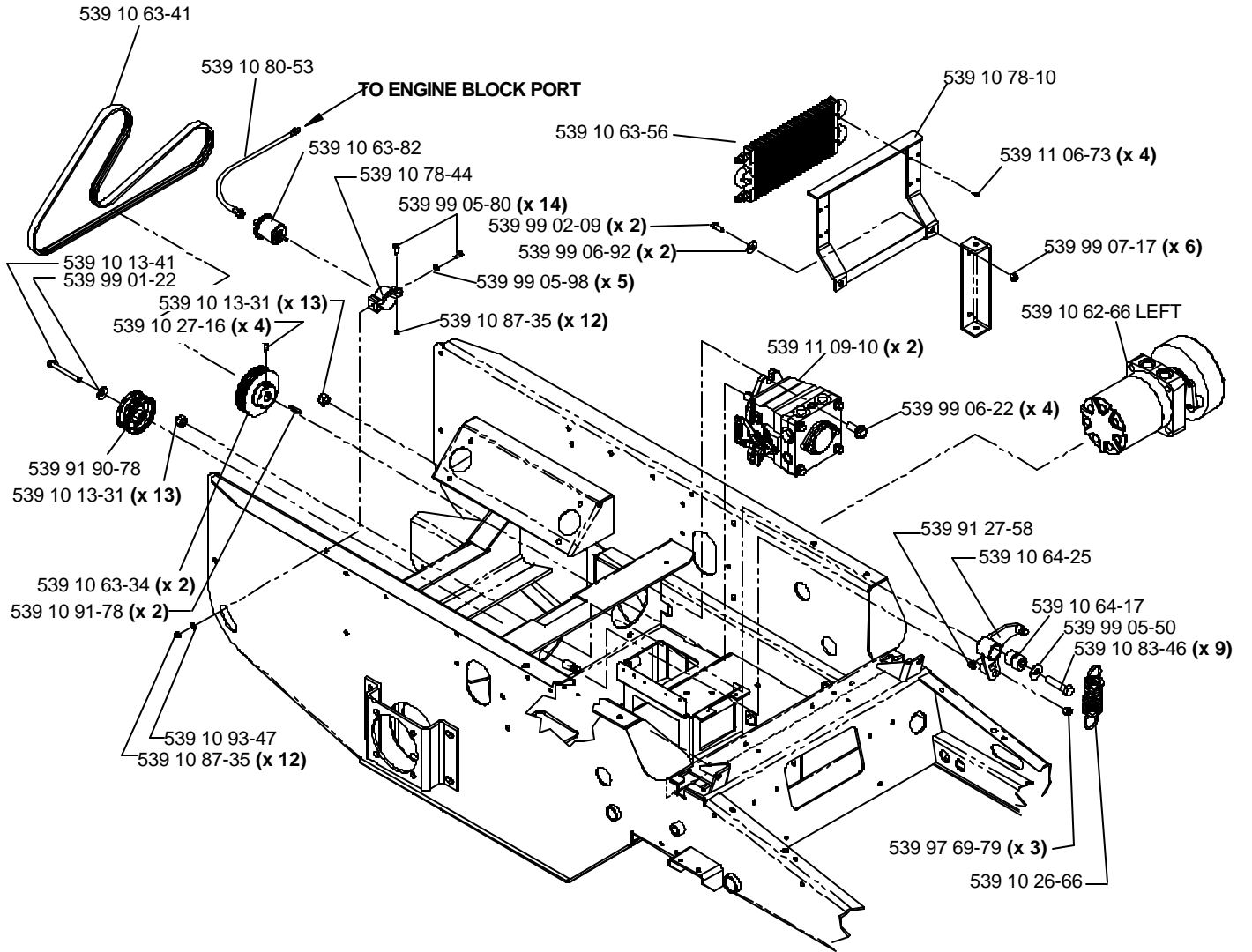

# FUEL GROUP

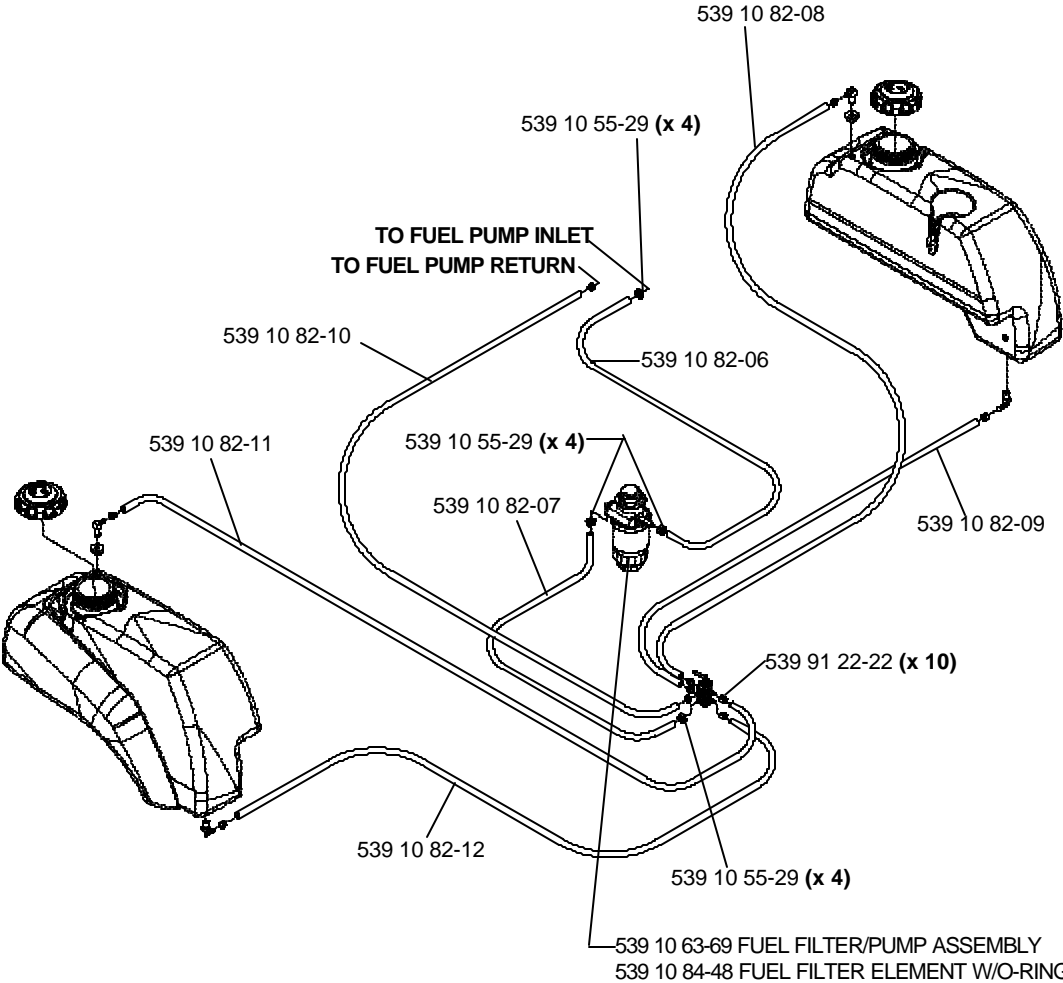



# FUEL GROUP

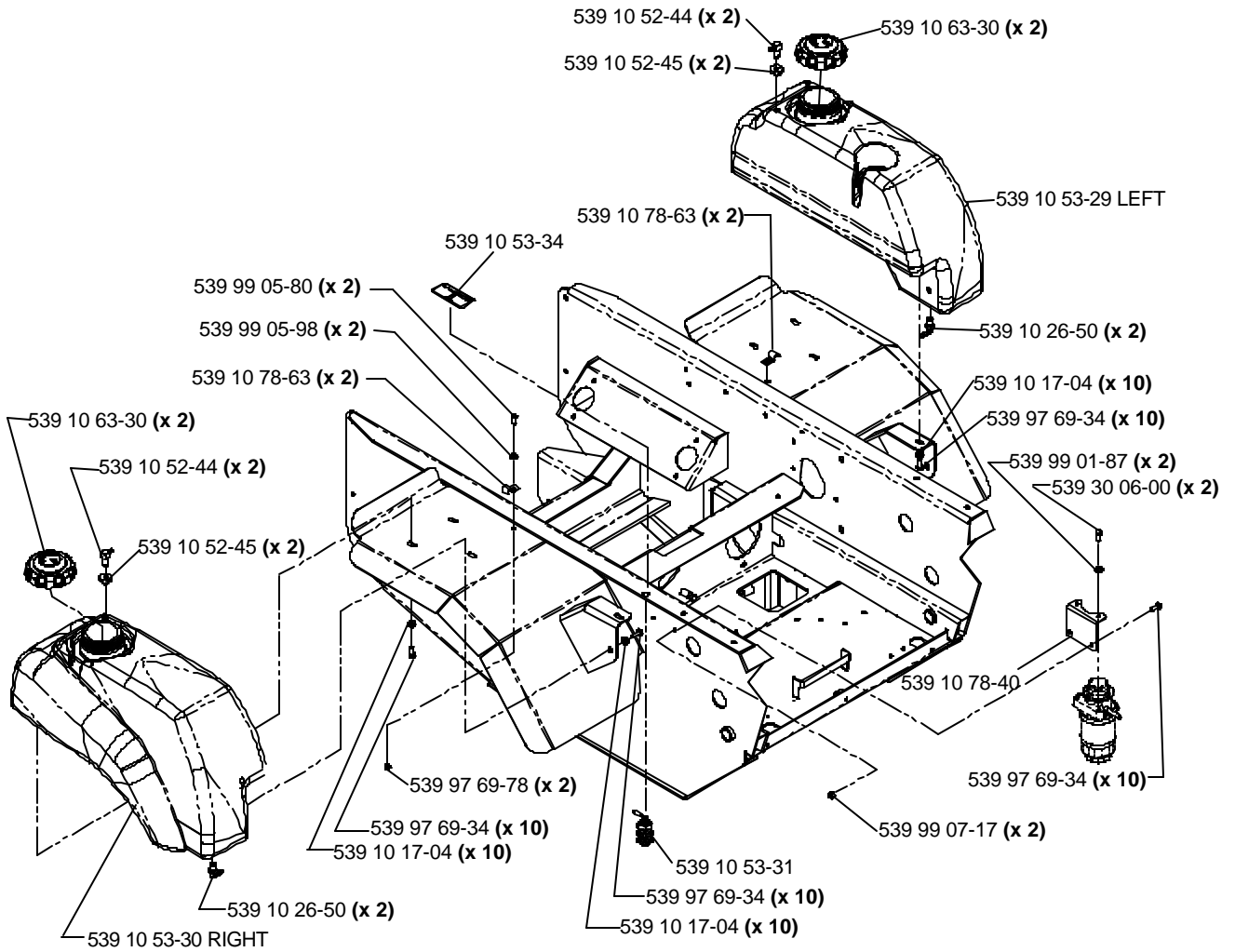

# BRAKE GROUP LINKAGE

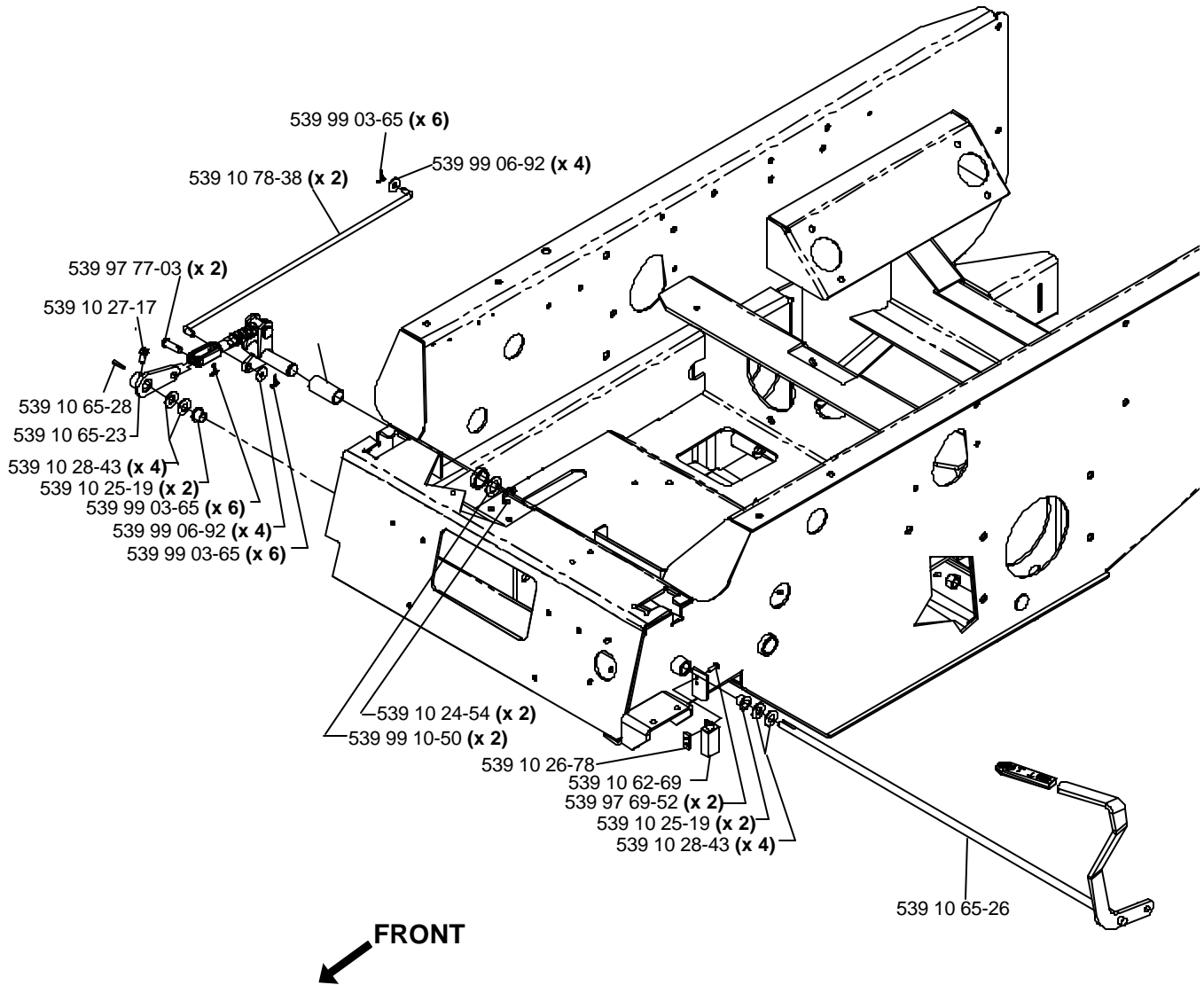

# BRAKE GROUP LINKAGE

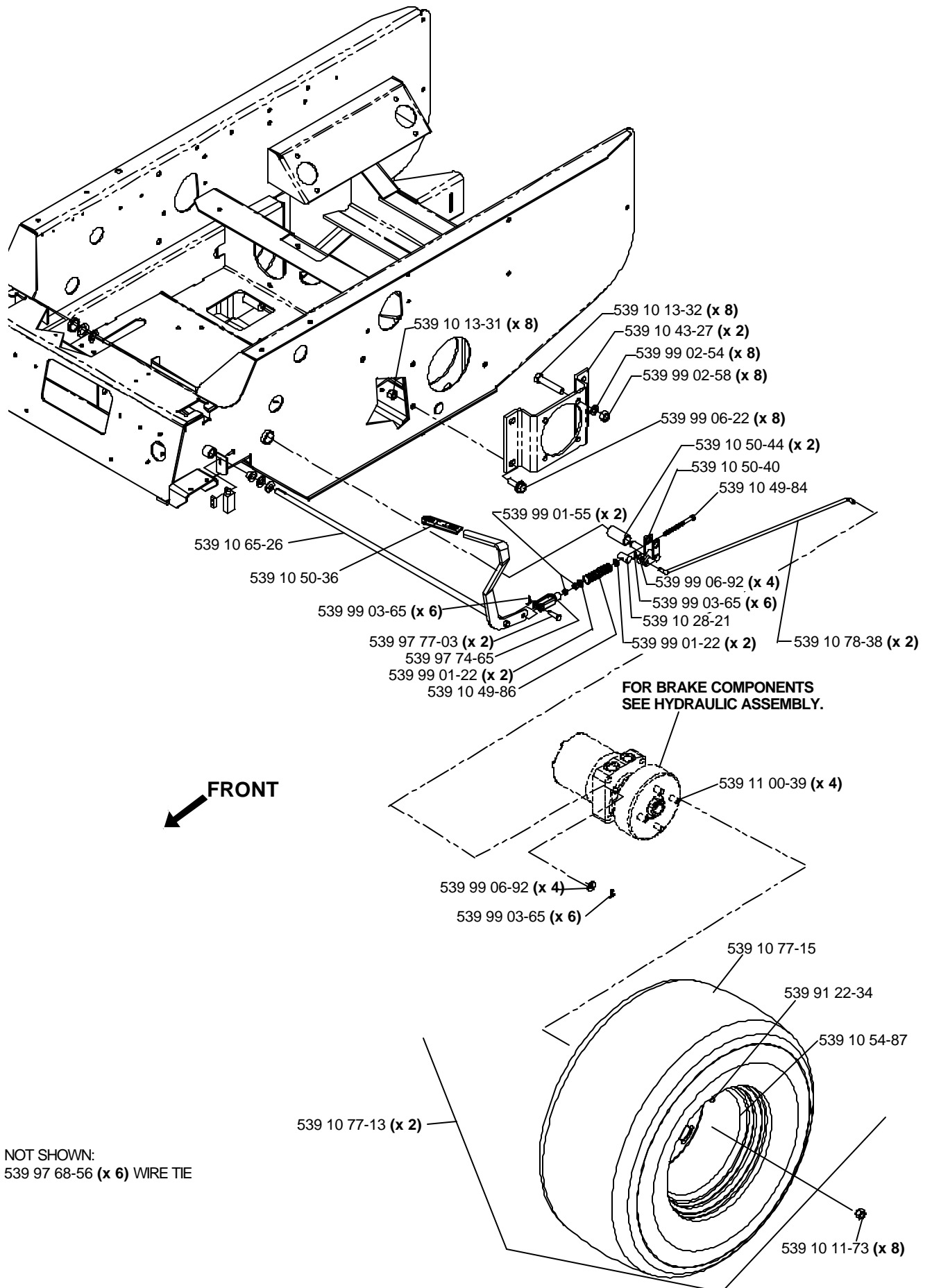

# SEAT ASSEMBLY

**NOT SHOWN:**

- 539 10 87-45 Switch-snap mount kit
- 539 11 14-34 Back, hard plastic prem seat

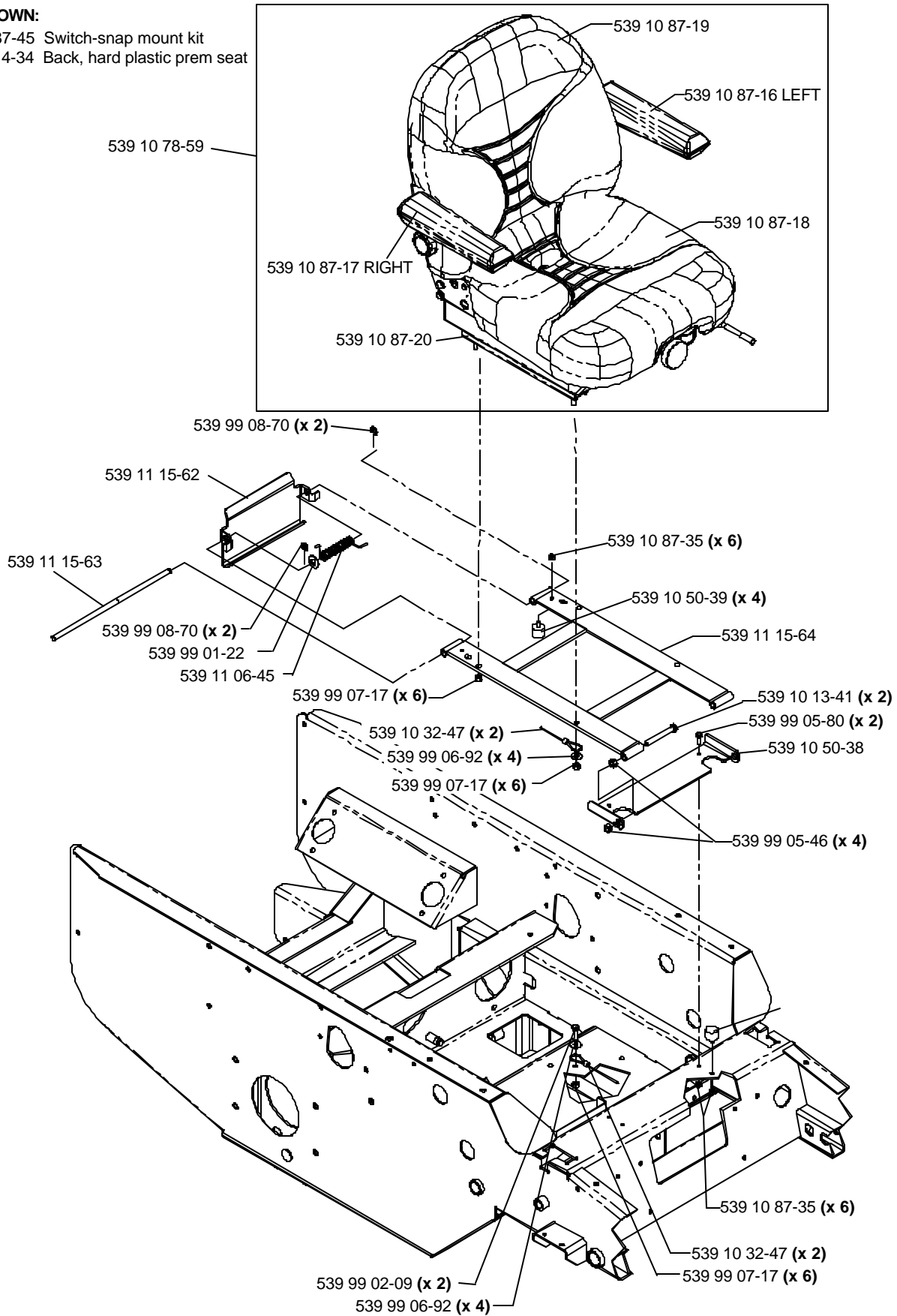

# FOOT PEDAL

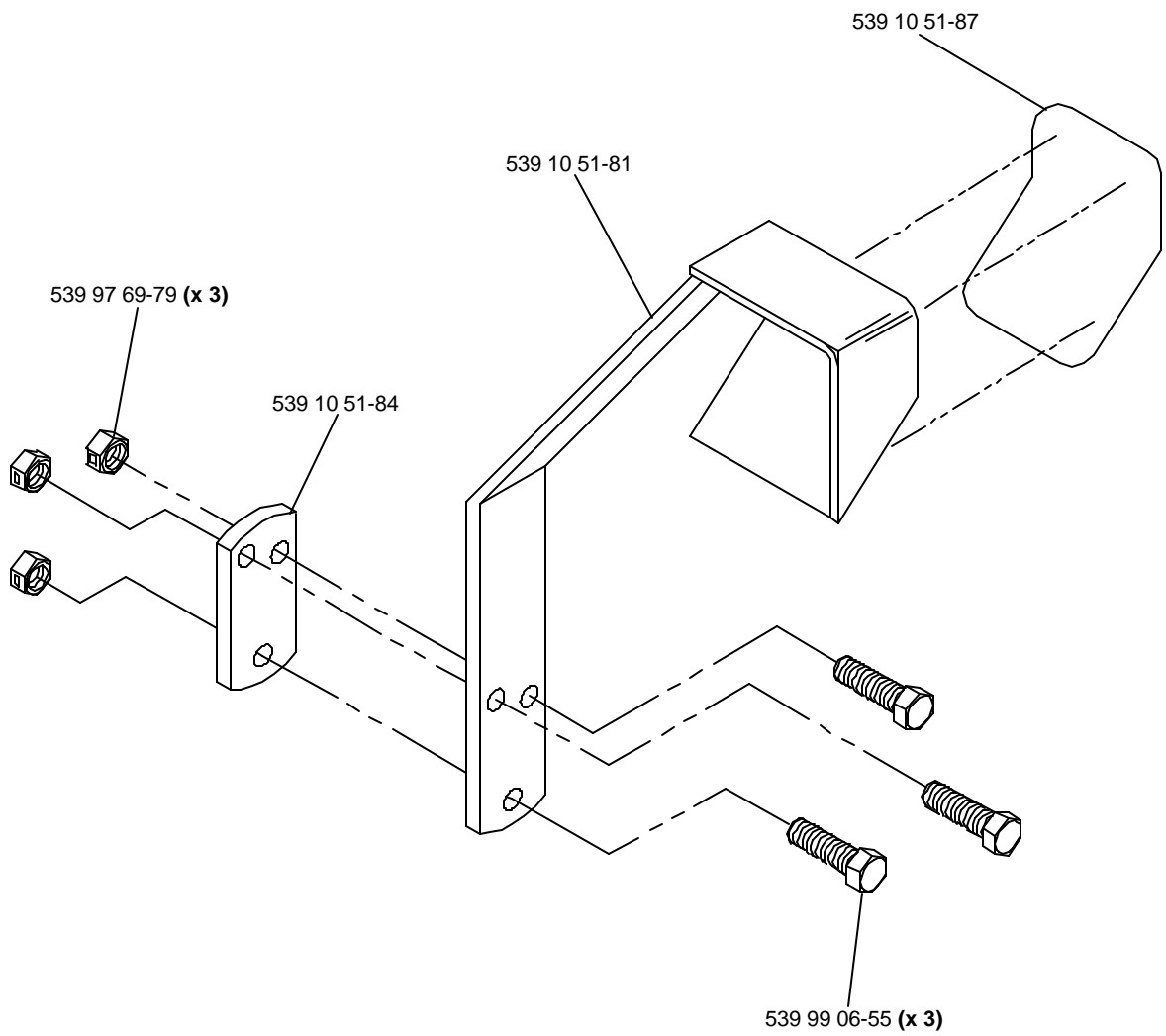

# CASTER ASSEMBLY

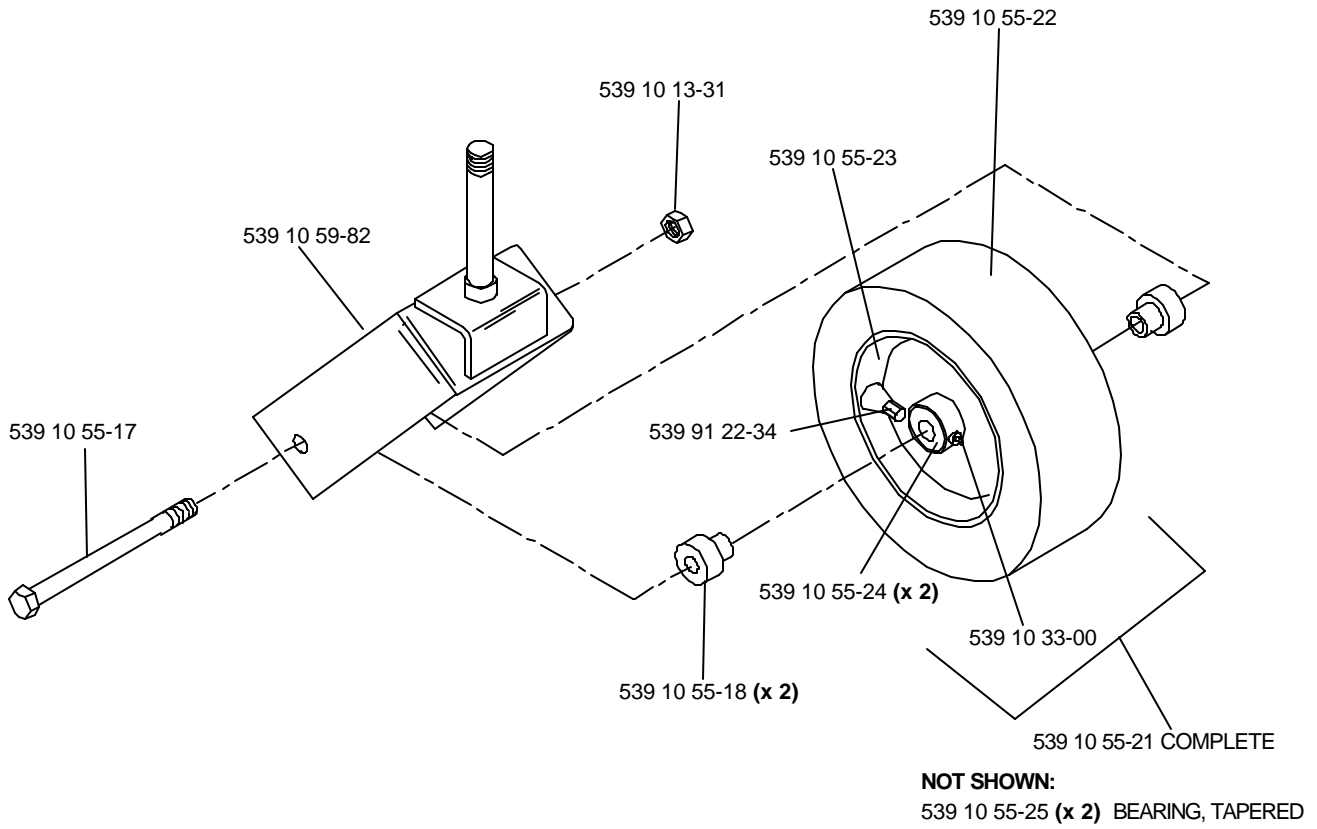

# DECK LIFT MANUAL

**NOT SHOWN:**

539 10 63-45 Plug (Top of Right Console)

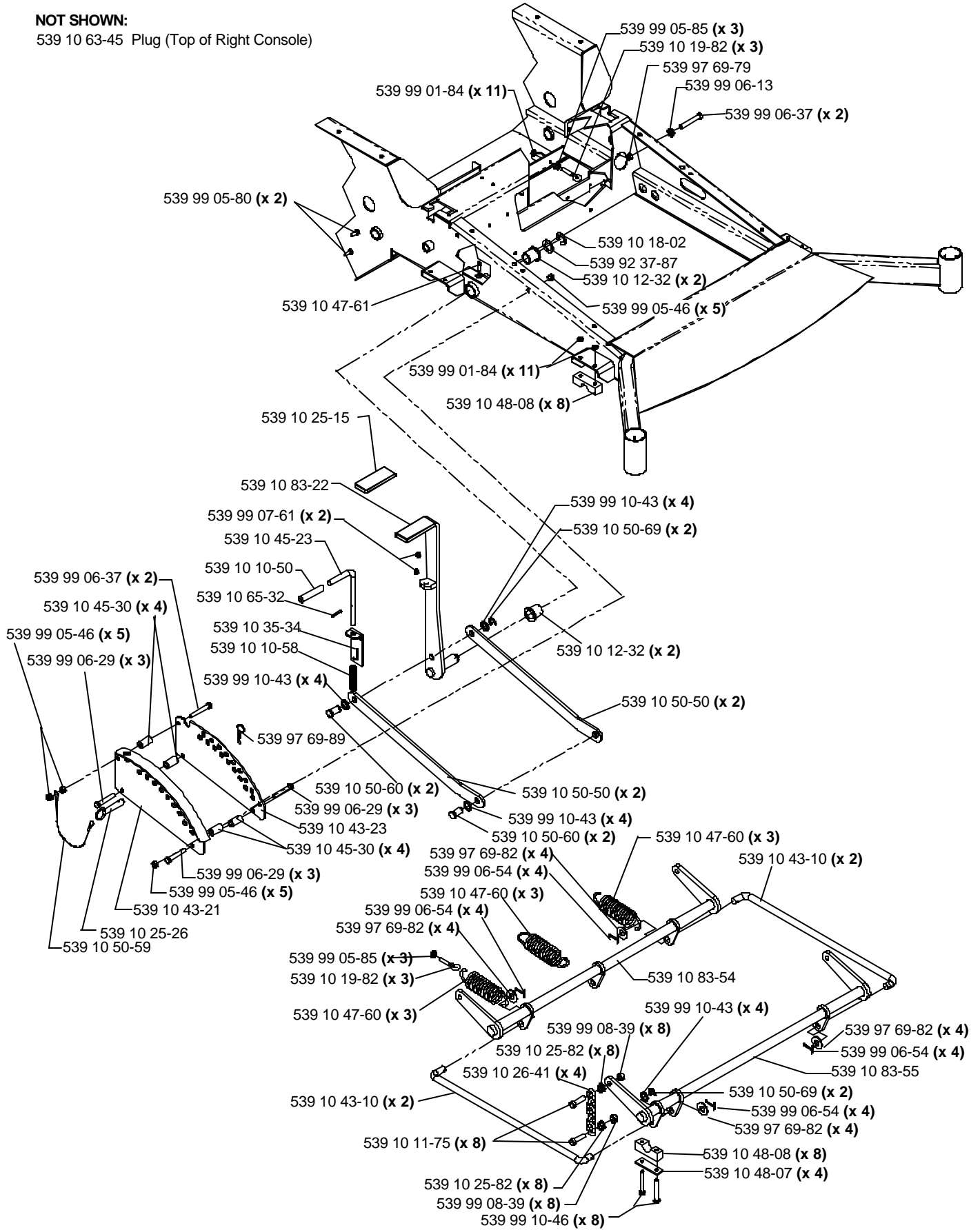

# DECK LIFT

## POWER

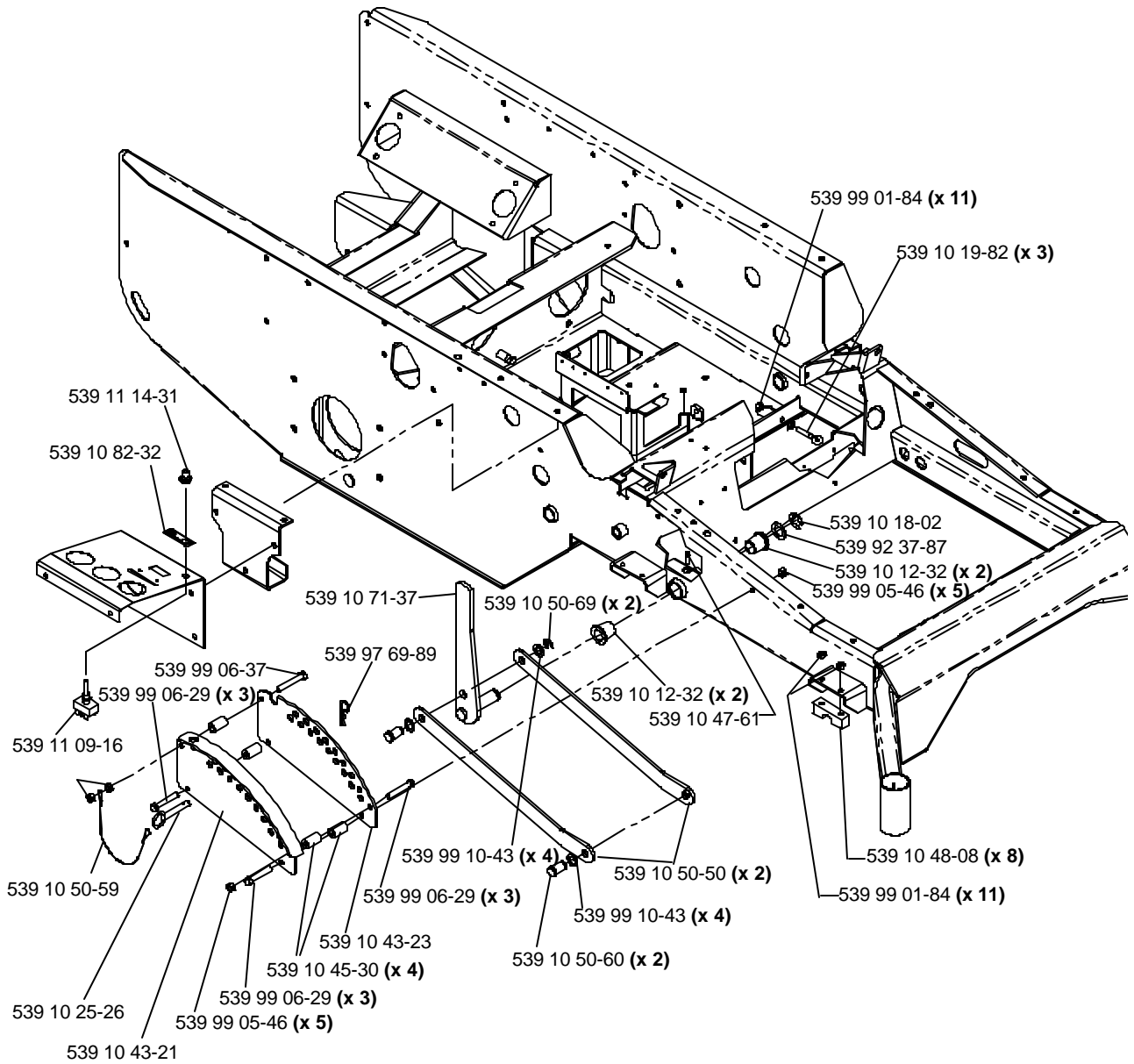



# DECK LIFT

## POWER

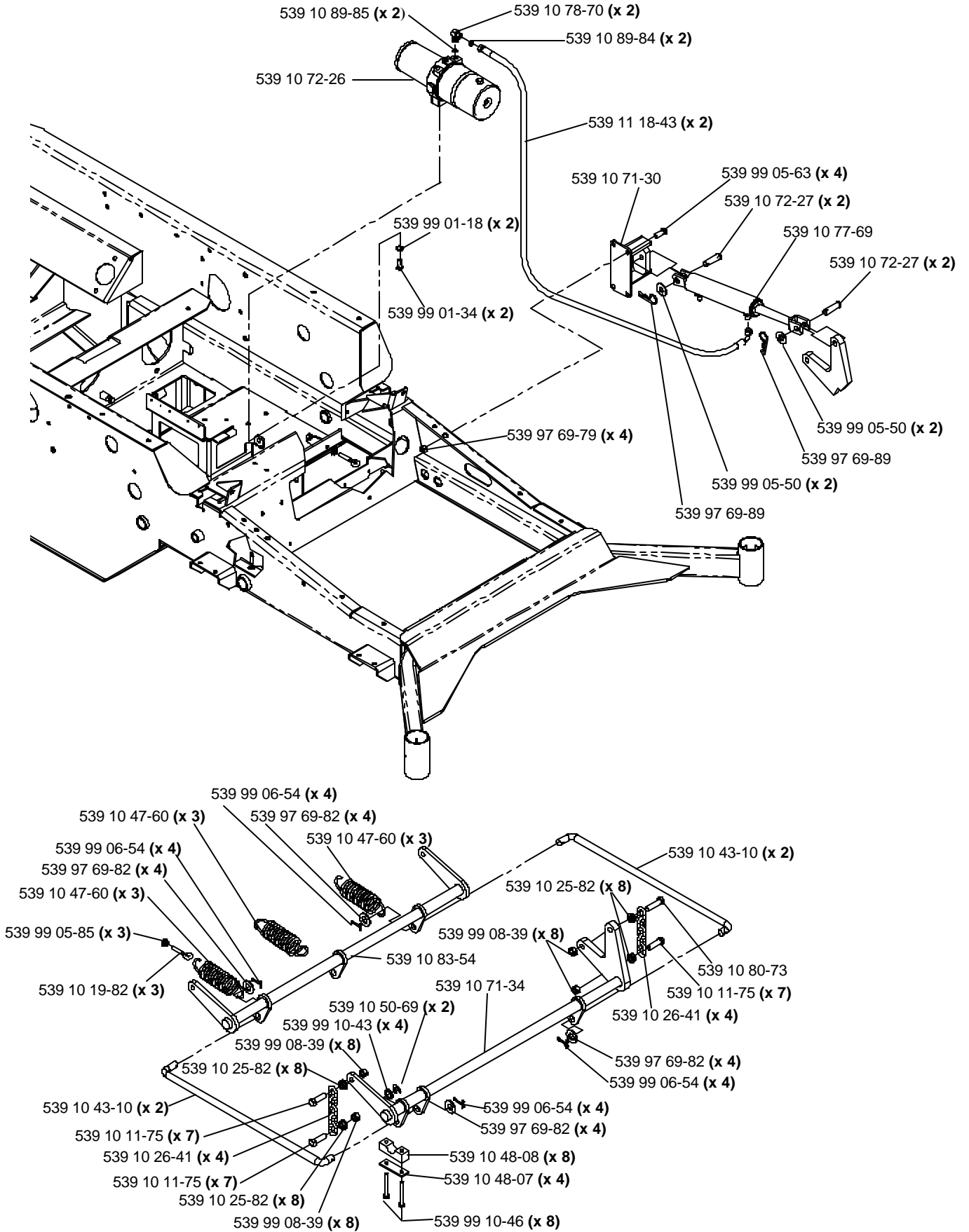

# DECK ASSEMBLY

61 INCH

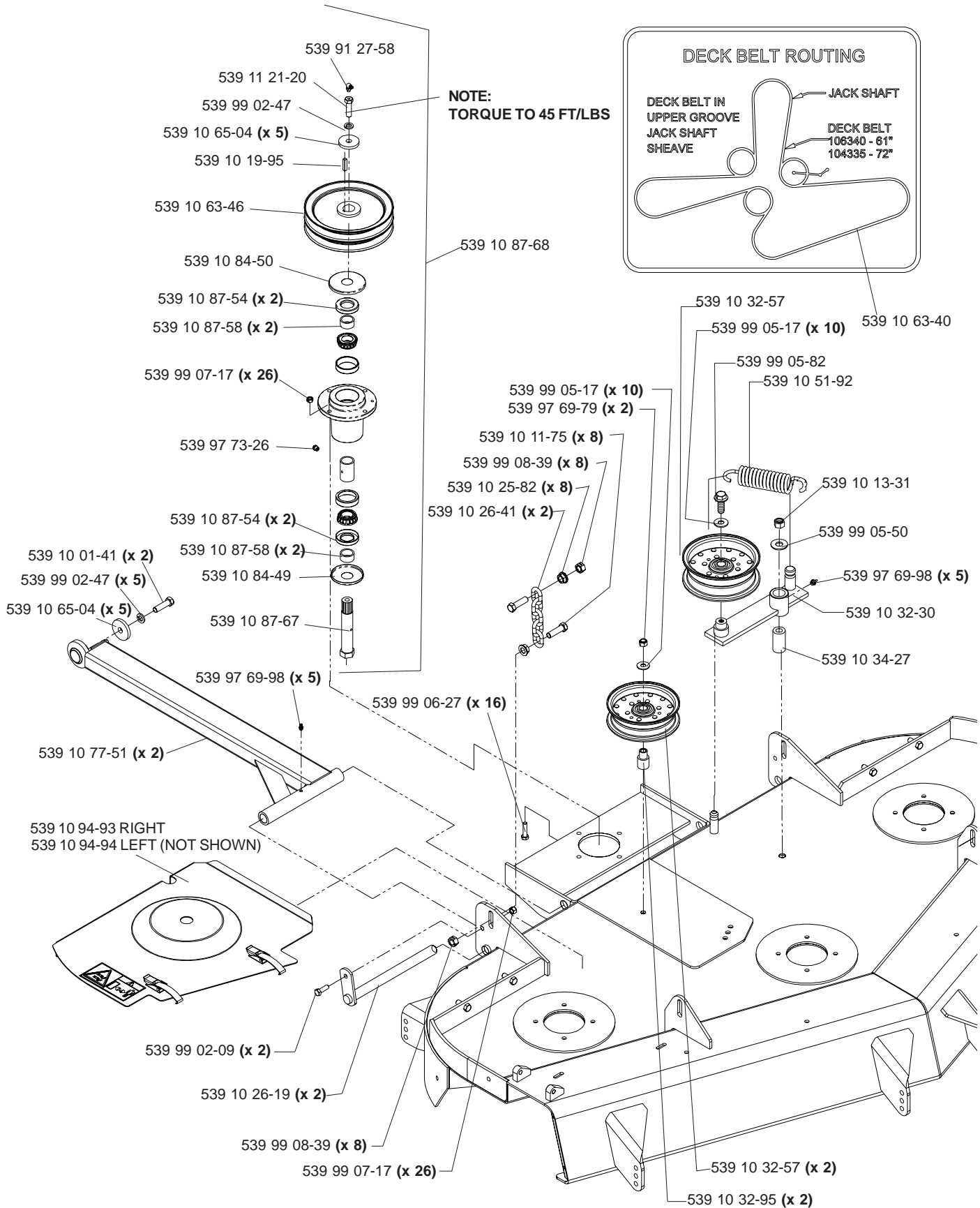

# DECK ASSEMBLY

61 INCH

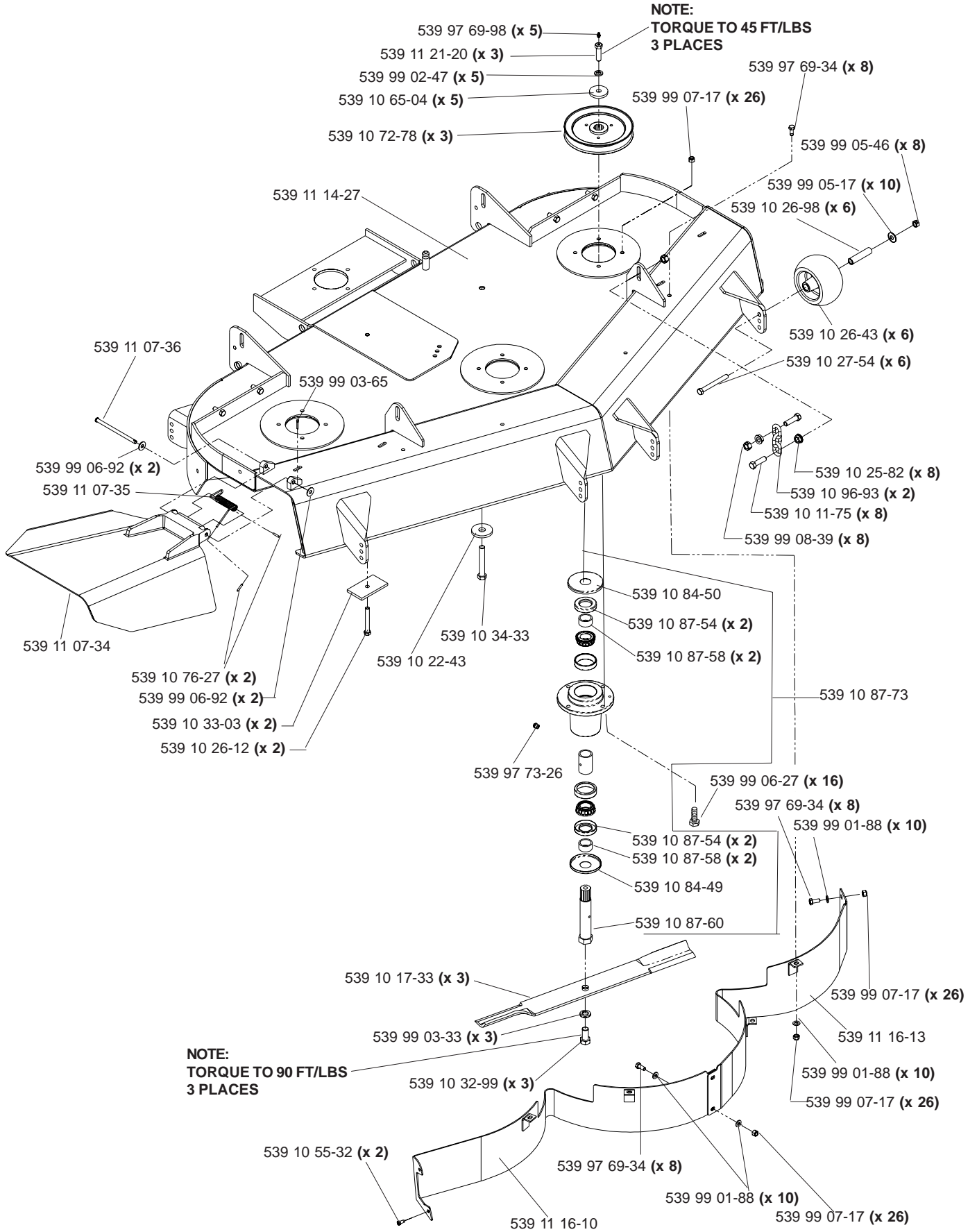

# DECK ASSEMBLY

72 INCH

**NOTE:**  
TORQUE TO 45 FT/LBS

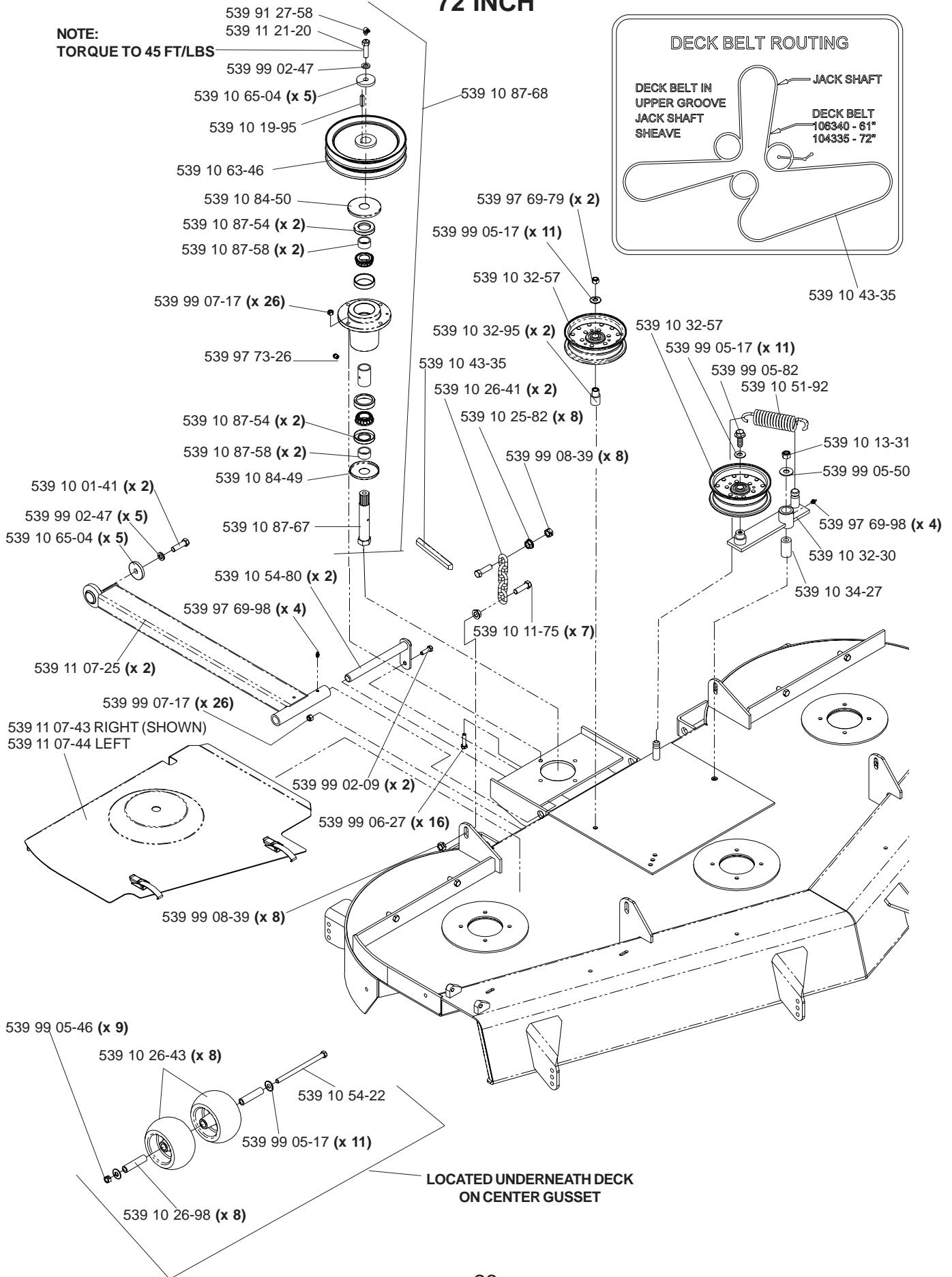
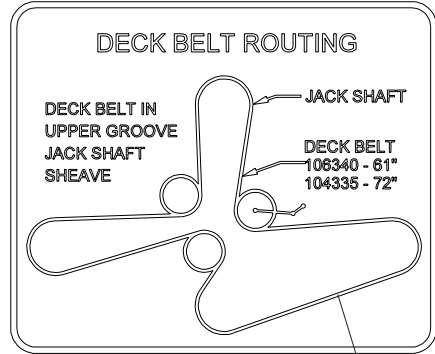

# DECK ASSEMBLY

## 72 INCH

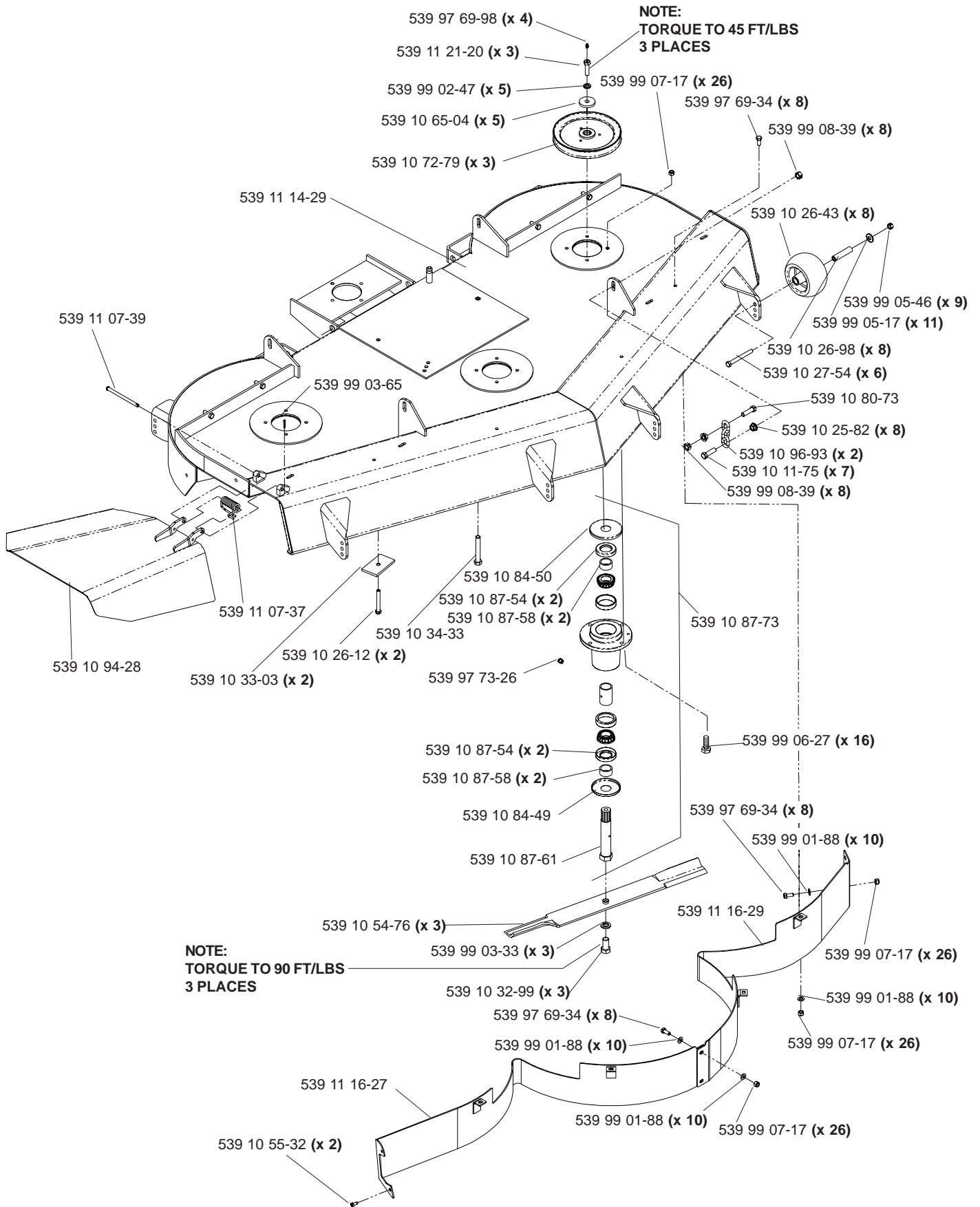

# DECALS

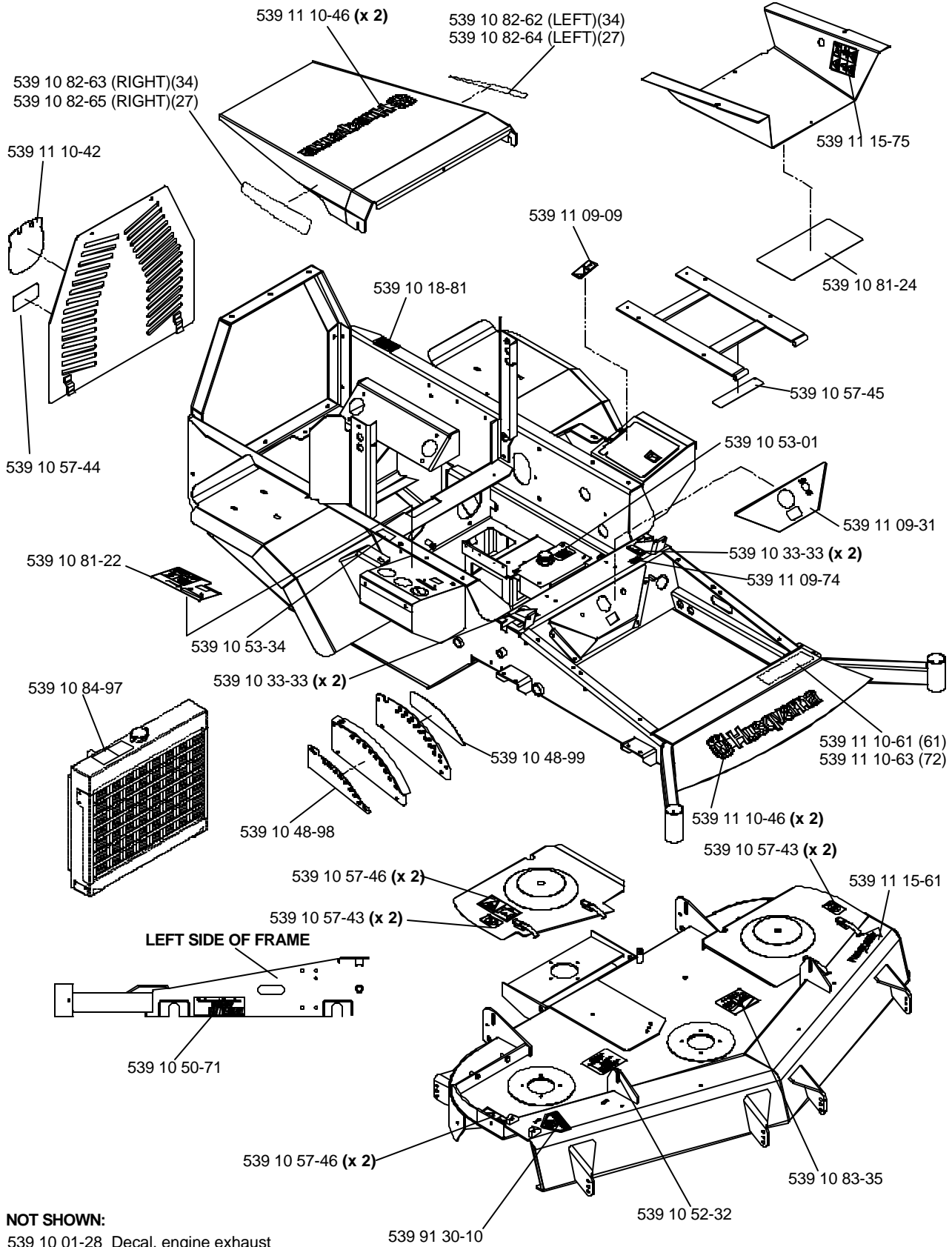

# ELECTRICAL GROUP

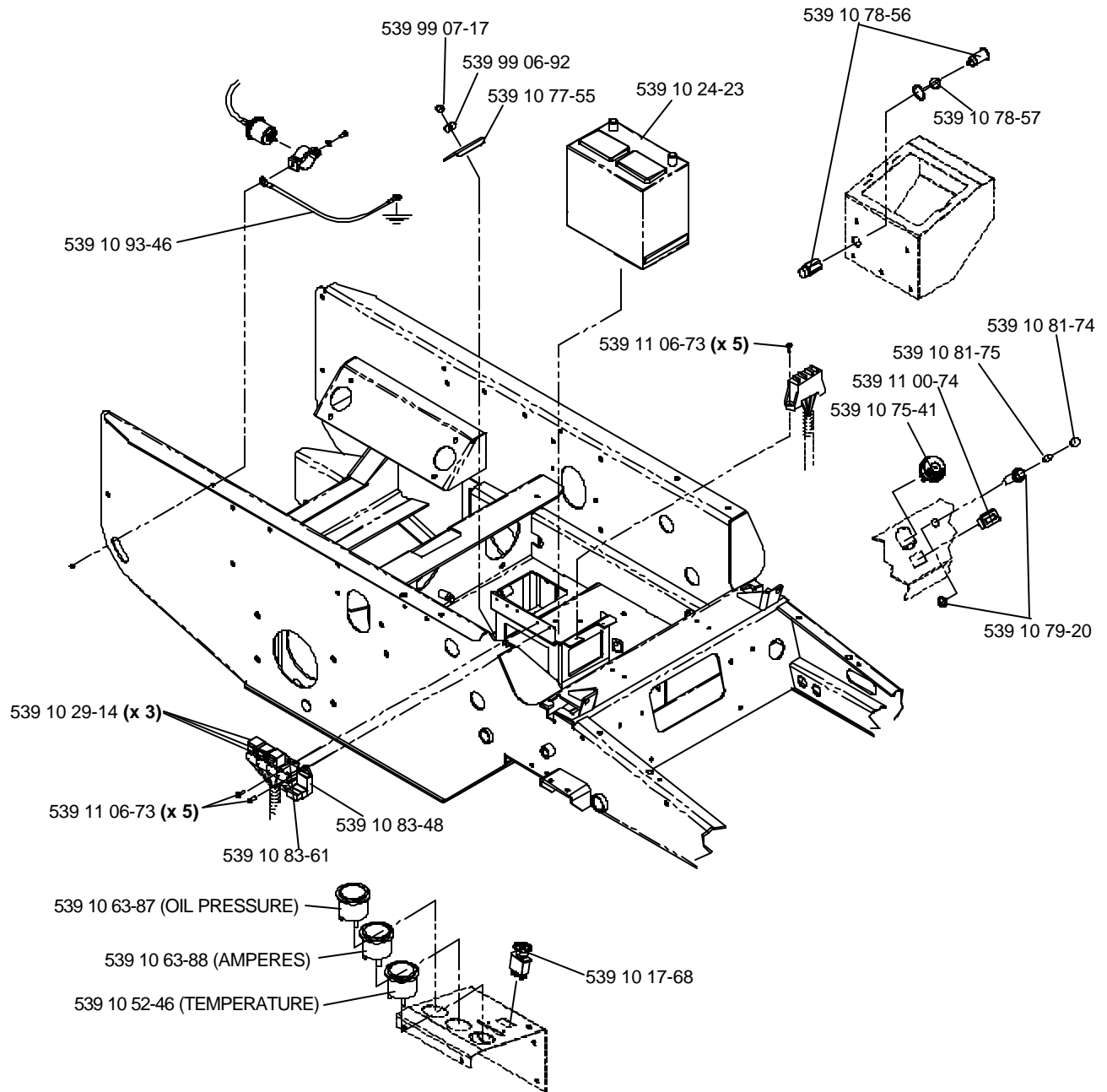

**NOT SHOWN:**

- 539 10 20-86 ..... Fuse, 20 AMP, 32 volts
- 539 10 89-78 (x 2) .... Fuse, 10 AMP, 32 volts
- 539 10 89-79 ..... Fuse, 30 AMP, 32 volts
- 539 10 89-80 ..... Fuse, 50 AMP, 32 volts





# WIRE HARNESS

## GAUGE WIRING VIEWED FROM TERMINAL SIDE

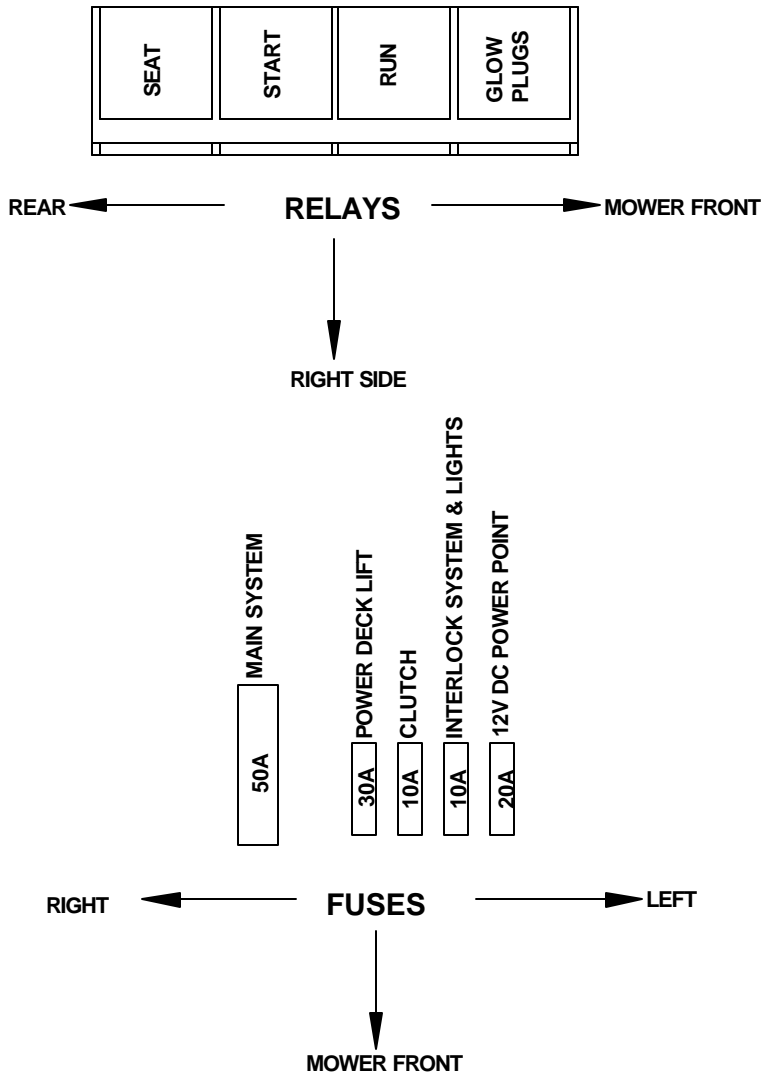
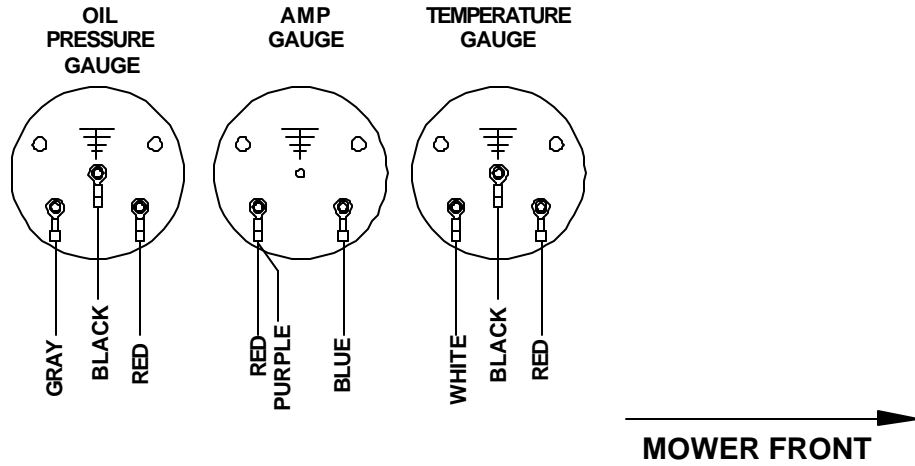

# WIRING SCHEMATIC

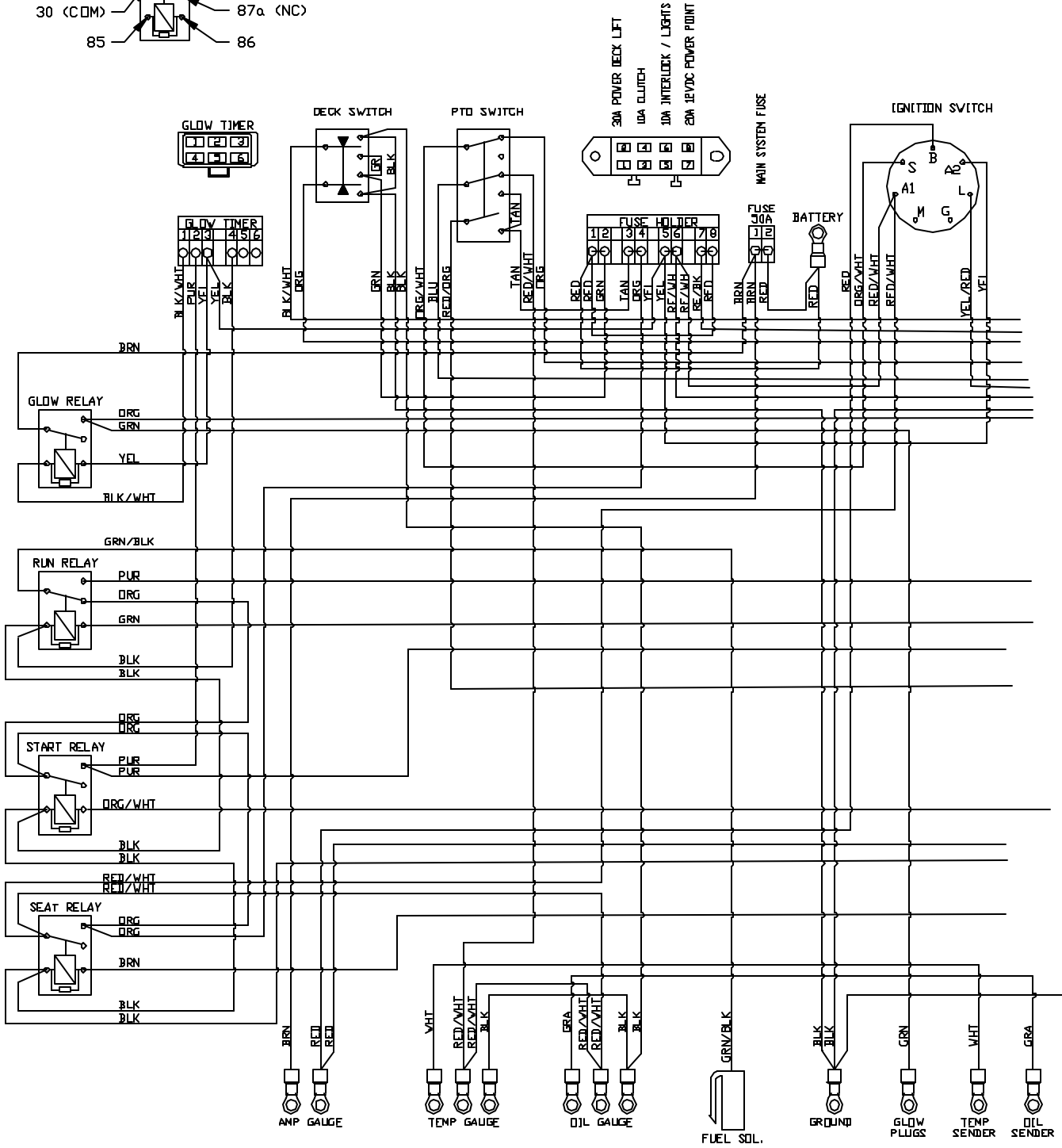
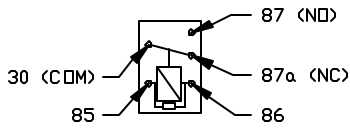
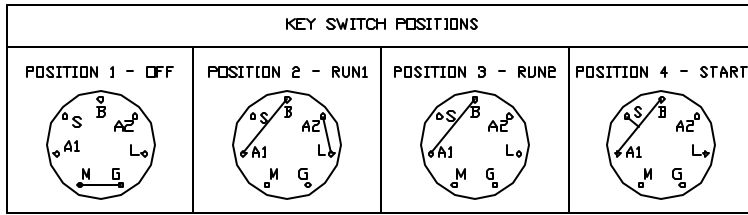

# WIRING SCHEMATIC

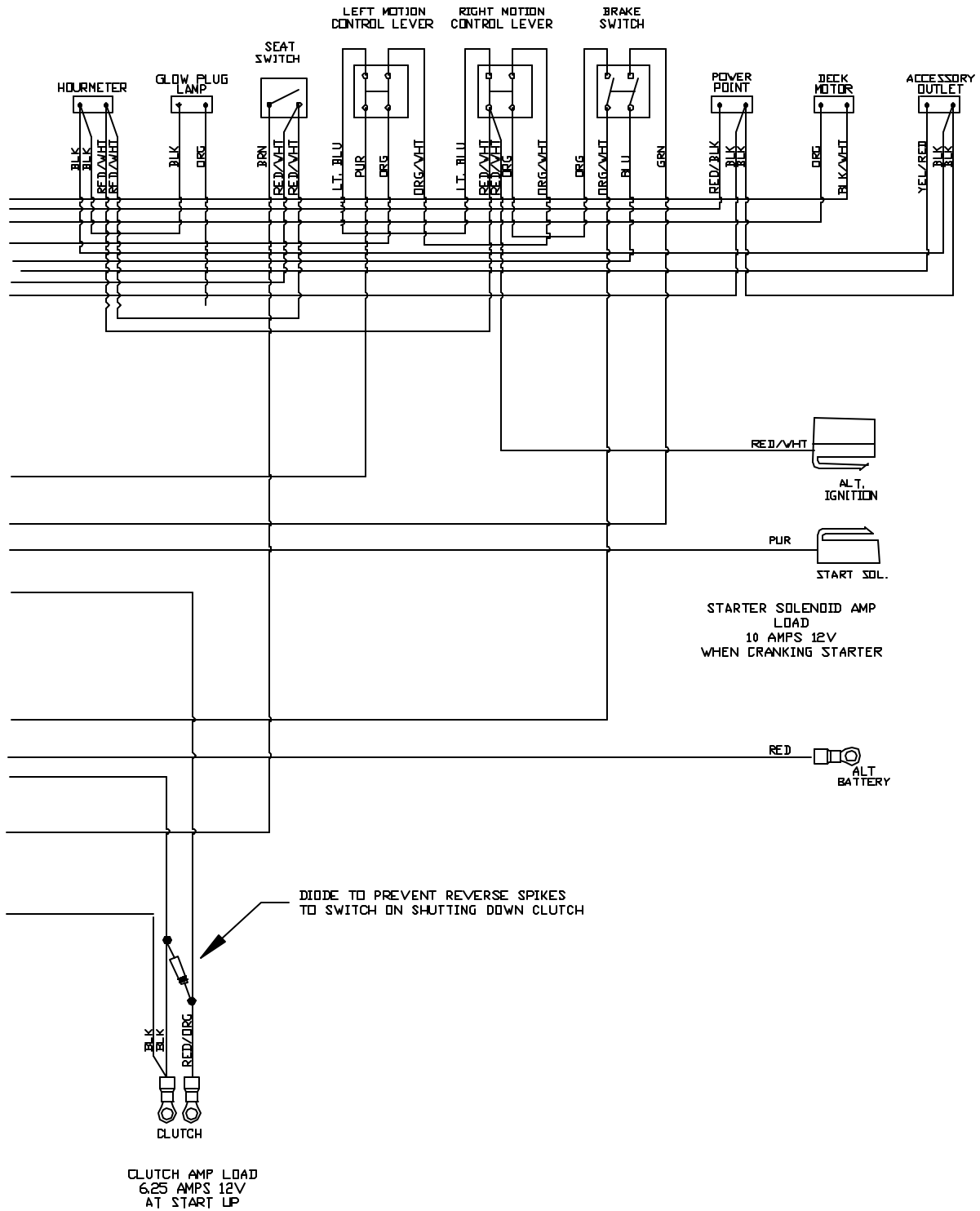

# ROPS

539 11 08-84 ROPS, COMPLETE W/SEAT BELT

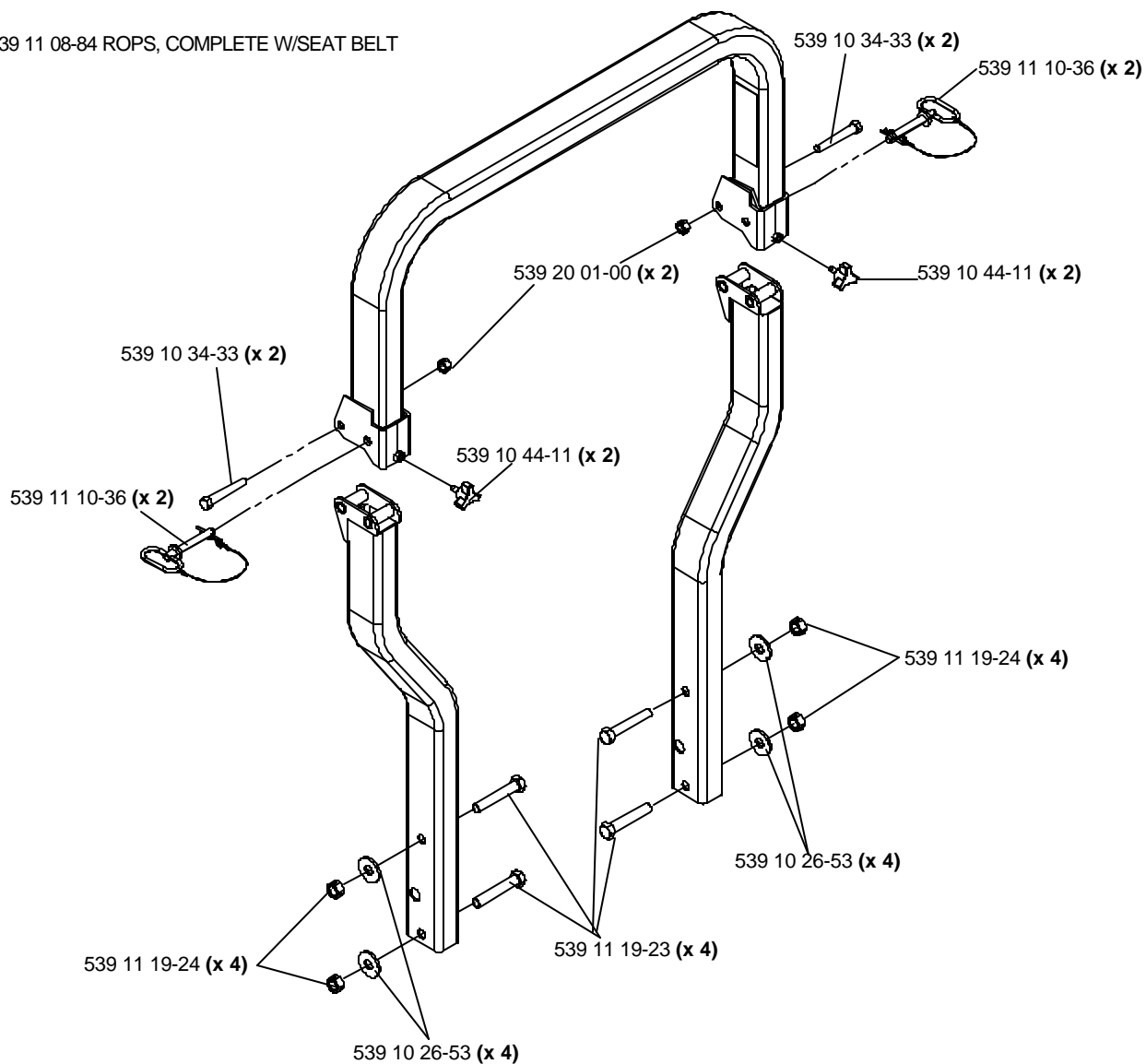

# ACCESSORIES

## MULCH KIT

61" PART NO. 539111353

NOTE: TIGHTEN ALL HARDWARE BY TURNING THE BOLT, NOT THE NUT.

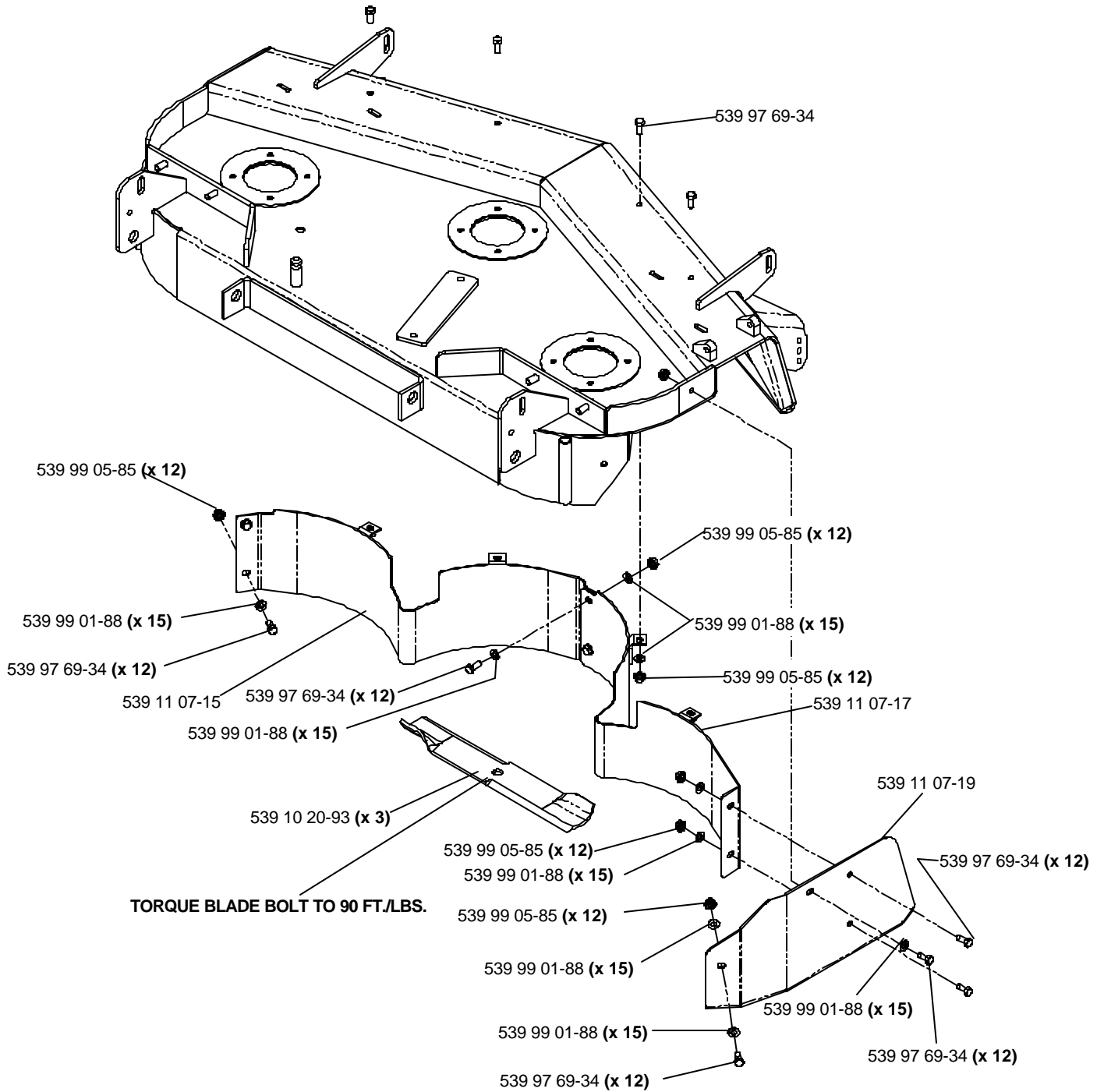

# ACCESSORIES

## MULCH KIT 72" PART NO. 539111354

NOTE: TIGHTEN ALL HARDWARE BY TURNING THE BOLT, NOT THE NUT.

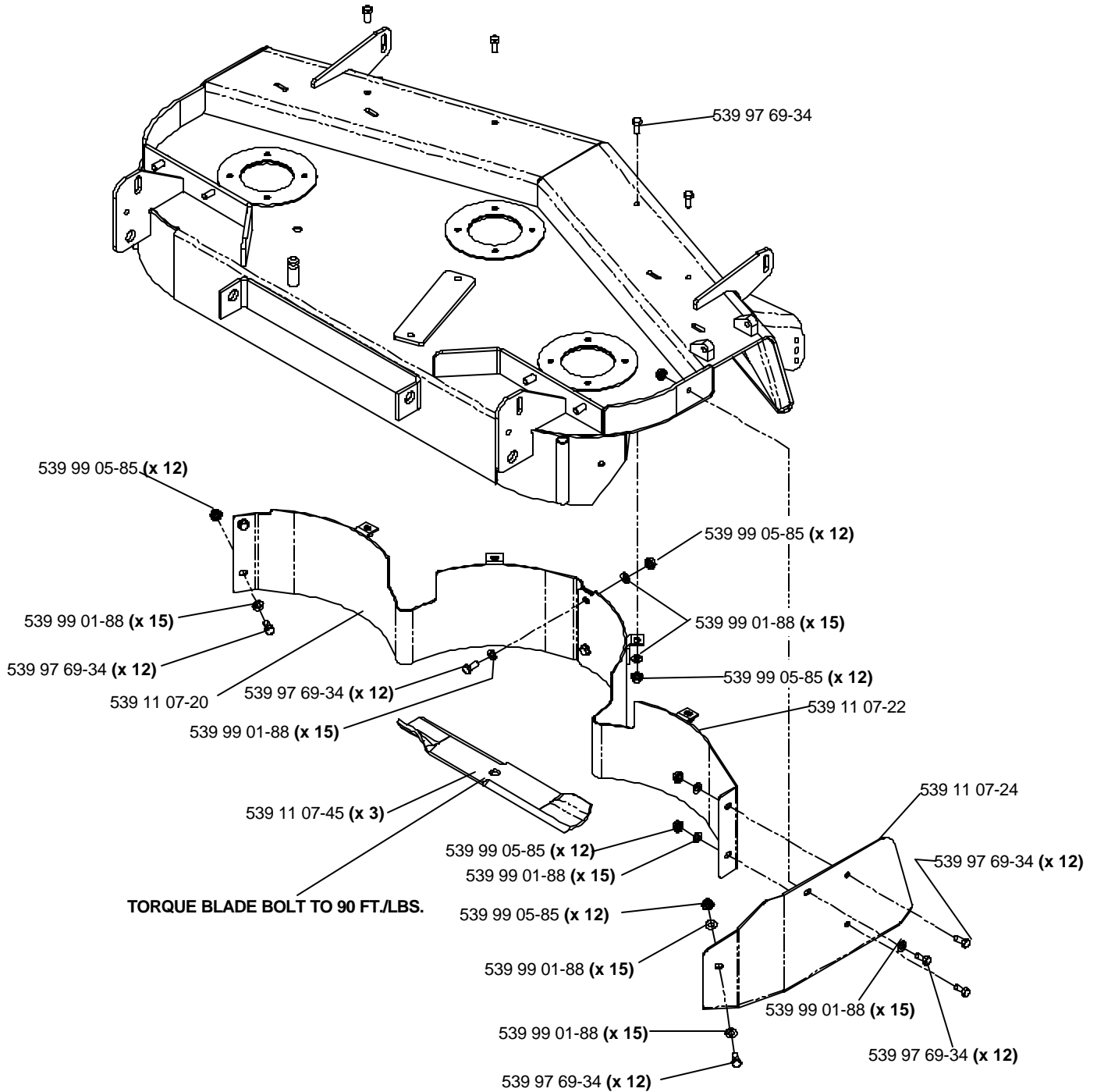



# ACCESSORIES

## FRONT Baffle Kits 72" PART NO. 539111635

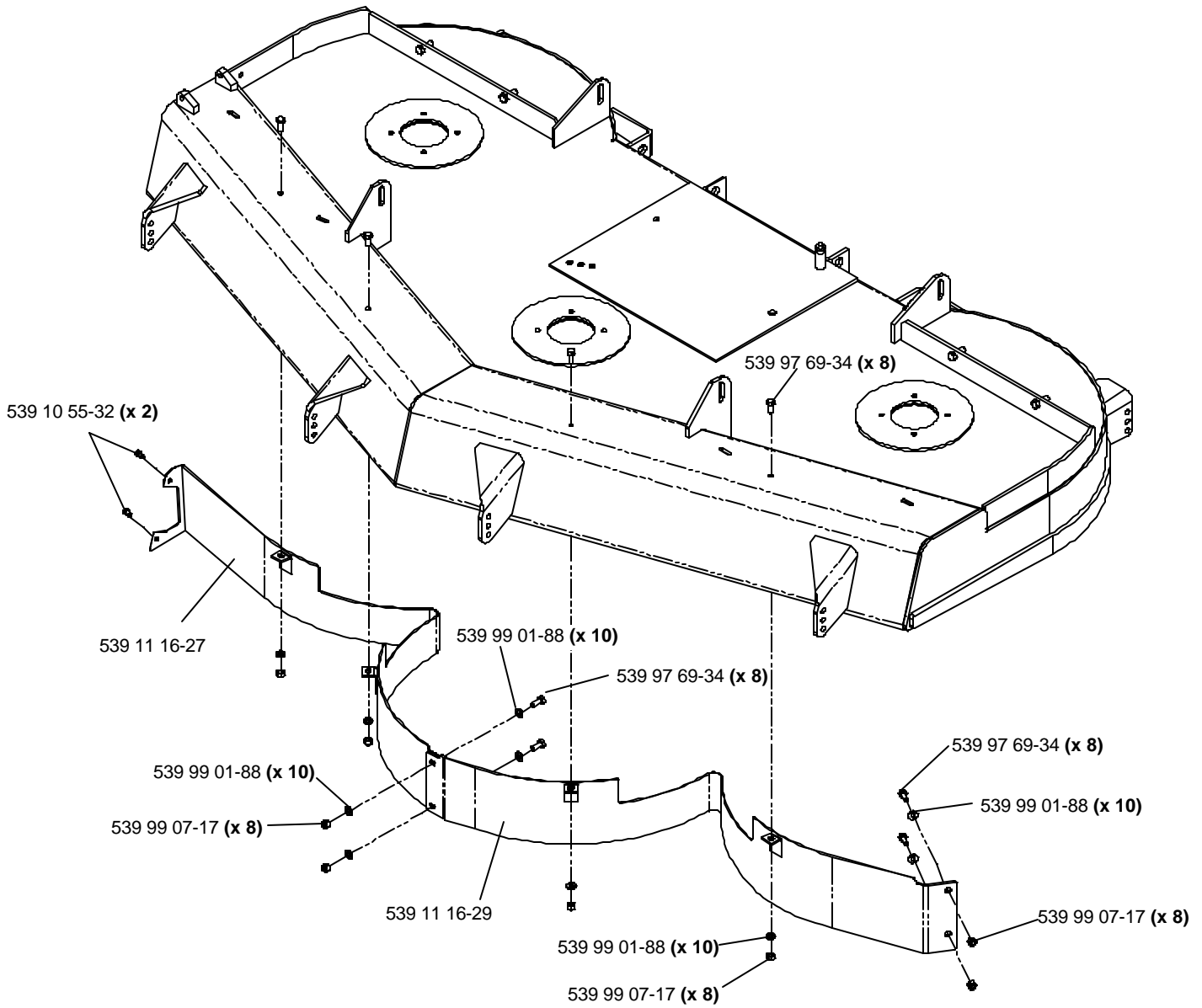



# PARTS DESCRIPTION

---

539 10 01-28	Decal, engine exhaust
539 10 01-41	Bolt, 7/16-20 x 1 1/2, GD.5
539 10 10-50	Grip
539 10 10-58	Spring
539 10 11-73	Nut, 1/2, lug
539 10 11-75	Bolt, 7/16-20 x 1 1/2, GD. 5, special
539 10 12-02	Oil cap
539 10 12-32	Bushing, flanged-PM
539 10 12-37	Straight connector
539 10 13-31	Nut, 1/2-13, nyloc
539 10 13-32	Bolt, 1/2-13 x 2 3/4
539 10 13-41	Bolt, 3/8-16 x 3
539 10 14-74	Zerk
539 10 17-04	Washer, 5/16, sealing
539 10 17-33	Blade, 21"
539 10 17-68	Switch, clutch
539 10 18-02	E-ring, 7/8
539 10 18-81	Decal, Prop 65
539 10 19-82	Eyebolt, right
539 10 19-95	Key, 1/4" sq. x 1 1/8"
539 10 20-86	Fuse, 20 AMP, 32 volts
539 10 20-93	Blade, mulch, 21"
539 10 22-43	Washer, support
539 10 22-44	Machine bushing, 18 ga
539 10 24-23	Battery
539 10 24-54	E-ring, 3/4
539 10 25-15	Grip
539 10 25-19	Bushing, bronze
539 10 25-26	Lift pin
539 10 25-35	Cap, grease
539 10 25-43	Bearing
539 10 25-82	Nut, 7/16-14, whiz
539 10 25-87	Stop, rubber
539 10 25-92	Grip
539 10 25-93	Washer, 3/8, spring
539 10 26-12	Hcs, 3/8-16 x 2 3/4 GD. 5
539 10 26-19	Pivot pin
539 10 26-41	Lift chain
539 10 26-43	Anti-scalp roller
539 10 26-50	Hose barb, 90°
539 10 26-53	Washer, 5/8
539 10 26-66	Spring
539 10 26-76	Spacer
539 10 26-77	Bearing
539 10 26-78	Plate, tapped
539 10 26-98	Bushing
539 10 27-16	Setscrew, 5/16-18 x 1
539 10 27-17	Setscrew, 5/16-18 sq. x 5/8
539 10 27-32	Cable, throttle

# PARTS DESCRIPTION

---

539 10 27-54	Bolt, 3/8-16 x 3 1/2
539 10 28-21	Pin, trunion
539 10 28-43	Washer, 7/16, spring
539 10 28-51	Seal
539 10 28-52	Nut, 1-14, slotted jam
539 10 28-89	Pin, cotter, 1/8 x 2
539 10 29-14	Relay
539 10 30-03	Knob, tracking
539 10 31-14	'O' ring
539 10 31-15	'O' ring
539 10 31-18	'O' ring
539 10 31-19	'O' ring
539 10 32-30	Idler arm
539 10 32-47	Seat lanyard
539 10 32-56	Spring
539 10 32-57	Pulley, idler
539 10 32-95	Bushing, idler
539 10 32-99	Hcs, 5/8-18 x 1 1/4, Gd.5
539 10 33-00	Zerk
539 10 33-03	Pad
539 10 33-33	Decal, Motion control
539 10 34-27	Bushing, pivot
539 10 34-33	Bolt, 1/2-13 x 3 1/4, Gd. 5
539 10 35-34	Pin mt, upper
539 10 35-47	Washer
539 10 36-84	Grommet
539 10 43-10	Link, connecting
539 10 43-21	Adjustment plate
539 10 43-23	Adjustment plate
539 10 43-27	Standoff, wheel motor
539 10 43-35	Belt, deck
539 10 44-11	Knob w/stud
539 10 45-23	Pin
539 10 45-30	Spacer
539 10 47-60	Spring, extension
539 10 47-61	Zerk, long
539 10 47-63	'U' clip, 5/16C
539 10 48-07	Bar, reinforcement
539 10 48-08	Pillow block
539 10 48-52	Housing
539 10 48-98	Decal, Height indication
539 10 48-99	Decal, Height indication
539 10 49-84	Bolt, 3/8-24 x 4 1/2, special
539 10 49-86	Spring
539 10 50-36	Grip, park brake
539 10 50-38	Bracket w/decals, seat
539 10 50-39	Stud plate mount
539 10 50-40	Bellcrank
539 10 50-44	Bearing, bronze
539 10 50-50	Lift linkage
539 10 50-59	Lanyard
539 10 50-60	Pin, clevis

# PARTS DESCRIPTION

---

539 10 50-69	E-ring, 5/8
539 10 50-71	Decal, NASCAR
539 10 51-68	Cap nut, reservoir drain
539 10 51-81	Pedal, lift
539 10 51-84	Plate, tightening
539 10 51-87	Pad, anti-skid
539 10 51-92	Spring
539 10 52-32	Decal, Anti-scalp
539 10 52-44	Elbow
539 10 52-45	Grommet, rubber
539 10 52-46	Gauge, temperature
539 10 52-77	Castle nut
539 10 53-01	Decal, Mobil
539 10 53-29	Fuel tank, left
539 10 53-30	Fuel tank, right
539 10 53-31	Valve, fuel
539 10 53-34	Decal, Fuel valve
539 10 54-22	Hcs, 3/8-16 x 6, Gd.8
539 10 54-76	Blade, 25"
539 10 54-80	Pin weldment
539 10 54-85	Pulley
539 10 54-87	Rim
539 10 55-17	Bolt, 1/2-13 x 9 1/2, GD. 5
539 10 55-18	Spacer, axle
539 10 55-21	Tire & wheel assembly
539 10 55-22	Tire
539 10 55-23	Rim
539 10 55-24	Seals
539 10 55-25	Bearing, tapered
539 10 55-29	Clamp
539 10 55-32	Screw, 1/4-20, tapping
539 10 57-43	Decal, Euro no step
539 10 57-44	Decal, Euro danger, belt drives
539 10 57-45	Decal, Euro battery warning
539 10 57-46	Decal, Euro servering
539 10 58-91	Reservoir
539 10 58-92	Filter head
539 10 58-93	Filter
539 10 59-82	Yoke, caster
539 10 62-66	Wheel motor, left
539 10 62-67	Wheel motor, right
539 10 62-69	Switch
539 10 62-90	Mount, filter
539 10 62-91	Isolator mount, engine
539 10 62-97	Bracket, isolator
539 10 63-00	Plate, skid
539 10 63-06	Jack mount
539 10 63-10	Isolator
539 10 63-13	Air filter
539 10 63-15	Air filter assembly
539 10 63-16	Radiator

# PARTS DESCRIPTION

---

539 10 63-17	Shroud
539 10 63-18	Debris guard
539 10 63-20	Cap, radiator
539 10 63-21	Clamp, hose
539 10 63-22	Drain, radiator
539 10 63-25	Hose, upper
539 10 63-26	Hose, lower
539 10 63-27	Stub shaft
539 10 63-30	Cap, diesel fuel
539 10 63-34	Sheave, pump
539 10 63-35	Sheave, engine
539 10 63-39	Belt, mule
539 10 63-40	Belt, 61"
539 10 63-41	Belt, pump
539 10 63-44	Spindle
539 10 63-45	Plug (Top of Right Console)
539 10 63-46	Sheave
539 10 63-47	Sheave
539 10 63-56	Cooler
539 10 63-57	Fitting, wheel motors
539 10 63-58	Fitting, pumps
539 10 63-59	Fitting, pumps (return side)
539 10 63-60	Hose, cooler-reservoir
539 10 63-62	Hose, T, filter, out-pumps
539 10 63-63	Hose, reservoir-filter, in
539 10 63-64	Hose, LL pump-LR mtr
539 10 63-65	Hose, RR pump-RF mtr
539 10 63-66	Hose, LR pump-LF mtr
539 10 63-67	Hose, RL pump-RR mtr
539 10 63-69	Fuel filter/pump assembly
539 10 63-70	Fitting
539 10 63-75	Indicator, air filter
539 10 63-76	Air filter assembly
539 10 63-77	Safety element
539 10 63-81	Hose
539 10 63-82	Sender, oil pressure
539 10 63-83	Clamp
539 10 63-84	Clamp
539 10 63-86	Sender, temperature
539 10 63-87	Gaure, oil pressure
539 10 63-88	Gauge, amperes
539 10 64-02	Overflow reservoir
539 10 64-05	Support, right
539 10 64-06	Support, left
539 10 64-17	Bushing
539 10 64-18	Arm
539 10 64-22	Arm
539 10 64-25	Arm
539 10 65-04	Washer, heavy
539 10 65-23	Brake arm
539 10 65-26	Brake lever
539 10 65-28	Key, 1/8 sq. x 7/8

# PARTS DESCRIPTION

---

539 10 65-32	Pin, 3/16 x 1 1/4, grooved
539 10 70-26	Bolt, 1/2-20 x 2, Gr.8,
539 10 71-30	Cylinder mounting
539 10 71-34	Shaft, lift, front
539 10 71-37	Lift lever
539 10 72-05	Fender, right
539 10 72-06	Fender, left
539 10 72-10	Grommet
539 10 72-26	Power unit, hydraulic lift
539 10 72-27	Pin, clevis, 1/2 x 1 3/4
539 10 72-72	Combo spacer
539 10 72-78	Pulley
539 10 72-79	Pulley
539 10 75-41	Switch, ignition
539 10 76-27	Cap-sleeve
539 10 76-56	Grommet
539 10 77-13	Tire, rear, assembly
539 10 77-15	Tire
539 10 77-51	Strut weldment
539 10 77-55	Clamp
539 10 77-69	Cylinder
539 10 77-76	Console, bottom
539 10 78-10	Mount, cooler
539 10 78-38	Brake linkage bar
539 10 78-40	Mounting bracket
539 10 78-41	Bracket, air filter
539 10 78-44	Clamp, oil sender
539 10 78-47	Frame, rear
539 10 78-53	Hood
539 10 78-55	Bracket, mounting
539 10 78-56	Power source housing
539 10 78-57	Power source cap
539 10 78-58	Grommet, bumper
539 10 78-59	Seat suspension
539 10 78-60	Air filter hose
539 10 78-61	Engine mount, left
539 10 78-62	Engine mount, right
539 10 78-63	Clip
539 10 78-64	Shield, heat
539 10 78-67	Stiffener
539 10 78-70	Fitting
539 10 79-20	Lamp socket
539 10 79-41	Cable, positive
539 10 79-42	Cable, negative
539 10 79-95	Spacer, fan
539 10 80-52	Bushing, machine, 1 1/8 x 10 ga.
539 10 80-53	Hose
539 10 80-55	Support
539 10 80-73	Bolt, 7/16-14 x 1 3/4, GR 5
539 10 81-22	Decal, Right Console
539 10 81-24	Decal, Service

# PARTS DESCRIPTION

---

539 10 81-74	Lens
539 10 81-75	Lamp
539 10 82-06	Fuel line (38")
539 10 82-07	Fuel line (35")
539 10 82-08	Fuel line (79")
539 10 82-09	Fuel line (57")
539 10 82-10	Fuel line (54")
539 10 82-11	Fuel line (34")
539 10 82-12	Fuel line (13")
539 10 82-32	Decal, lift switch
539 10 82-62	Decal, 34 Turbo, left
539 10 82-63	Decal, 34 Turbo, right
539 10 82-64	Decal, 27 Diesel, left
539 10 82-65	Decal, 27 Diesel, right
539 10 82-71	Bolt, 3/8-16 x 3 1/2
539 10 83-22	Lever
539 10 83-35	Decal, Belt routing
539 10 83-46	Bolt, 1/2-13 x 2 1/2
539 10 83-48	Timer/glow plug
539 10 83-54	Shaft, lift, rear
539 10 83-55	Shaft, lift, front
539 10 83-61	Relay, glow plug
539 10 83-62	Panel, back, w/decals
539 10 83-91	Hcs, 1/4C x 3
539 10 83-94	Hcs, 5/16C x 1 3/4, tapping
539 10 84-48	Fuel filter element w/O-ring
539 10 84-49	Dust cap, bottom
539 10 84-50	Dust cap, top
539 10 84-70	Body, 90°
539 10 84-71	Body
539 10 84-72	S-drain
539 10 84-73	Precleaner assembly
539 10 84-74	Mounting bracket
539 10 84-75	Clamp
539 10 84-76	Hinge
539 10 84-97	Decal, HOT
539 10 85-23	Return spring
539 10 85-24	Shoe assembly
539 10 85-25	Lever
539 10 85-26	Clip
539 10 87-16	Armrest kit, left
539 10 87-17	Armrest kit, right
539 10 87-18	Seat cushion kit
539 10 87-19	Back cushion kit
539 10 87-20	Slide kit, seat adjustment
539 10 87-35	Nut, 1/4-20
539 10 87-45	Switch-snap mount kit
539 10 87-54	Shaft seal
539 10 87-58	Spacer
539 10 87-60	Mini spindle
539 10 87-61	Spindle

# PARTS DESCRIPTION

---

539 10 87-67	Jackshaft spindle
539 10 87-68	Jackshaft assembly, lower
539 10 87-73	Cutter housing, complete
539 10 89-78	Fuse, 10 AMP, 32 volts
539 10 89-79	Fuse, 30 AMP, 32 volts
539 10 89-80	Fuse, 50 AMP, 32 volts
539 10 89-83	'O' ring
539 10 89-84	'O' ring
539 10 89-85	'O' ring
539 10 91-77	Manifold gasket
539 10 91-78	Key, metric
539 10 93-46	Ground
539 10 93-47	Washer, 1/4, external star
539 10 94-28	Chute, discharge
539 10 94-93	Belt shield, 61", right
539 10 94-94	Belt shield, 61", left
539 10 96-93	Lift chain - 3 link
539 10 98-01	Nut, M8-1.25, stover top lock
539 11 00-39	Wheel stud, 1/2-20 x 1 3/8, Gr8
539 11 00-74	Hourmeter
539 11 06-03	Rod end, spherical, right
539 11 06-04	Rod end, spherical, left
539 11 06-06	Dampener
539 11 06-07	Ball stud
539 11 06-38	Arm, control shaft
539 11 06-45	Spring, torsion
539 11 06-54	Restraint
539 11 06-55	Spring
539 11 06-68	Clutch
539 11 06-73	Screw, #10-12 x 3/4
539 11 07-15	61" baffle, LEFT
539 11 07-17	61" baffle, RIGHT
539 11 07-19	61" mulch cap
539 11 07-20	72" baffle, LEFT
539 11 07-22	72" baffle, RIGHT
539 11 07-24	72" mulch cap
539 11 07-25	Strut weldment
539 11 07-34	Chute, discharge
539 11 07-35	Spring, torsion
539 11 07-36	Pin, clevis, 5/16 x 5 3/16
539 11 07-37	Spring, torsion
539 11 07-39	Pin, clevis 5/16 x 4 11/16
539 11 07-43	Shield, belt, right
539 11 07-44	Shield, belt, left
539 11 07-45	Blade, mulch, 25"
539 11 08-26	Drive lever, right
539 11 08-27	Drive lever, left
539 11 08-50	Sleeve
539 11 08-51	Sleeve
539 11 08-84	Rops, complete w/seat belt
539 11 08-96	Pump linkage bar
539 11 08-97	Control, left

# PARTS DESCRIPTION

---

539 11 08-98	Control, right
539 11 09-00	Bushing
539 11 09-01	Sleeve
539 11 09-04	Panel, top left
539 11 09-07	Control panel
539 11 09-09	Decal, 12V DC
539 11 09-10	Pump
539 11 09-12	Support, tank
539 11 09-15	Harness, engine, diesel
539 11 09-16	Switch
539 11 09-20	Door
539 11 09-22	Retainer
539 11 09-23	Latch
539 11 09-25	Console
539 11 09-27	Stop
539 11 09-30	Hose, T, pumps-cooler
539 11 09-31	Decal, Console
539 11 09-34	Console, support
539 11 09-41	Frame w/decals
539 11 09-43	Nut, 5/16F, nyloc
539 11 09-74	Decal, F.S.T.
539 11 10-36	Lanyard w/ping, 1/2"
539 11 10-39	Spring
539 11 10-42	Decal, crown
539 11 10-46	Decal, Husqvarna
539 11 10-61	Decal, BZ6127D
539 11 10-63	Decal, BZ7234D
539 11 14-27	61" Deck w/decals
539 11 14-29	72" Deck w/decals
539 11 14-31	Switch boot
539 11 14-34	Back, hard plastic prem seat
539 11 15-61	Decal, Tunnel Ram
539 11 15-62	Latch
539 11 15-63	Pin
539 11 15-64	Seat mount
539 11 15-67	Idler
539 11 15-68	Idler
539 11 15-74	Pan, floor, w/decals
539 11 15-75	Decal, Euro warning
539 11 15-82	Belt, primary
539 11 16-10	61" front baffle, RIGHT
539 11 16-13	61" front baffle, LEFT
539 11 16-27	72" front baffle, RIGHT
539 11 16-29	72" front baffle, LEFT
539 11 18-06	Shoe assembly, complete w/backing plate
539 11 18-07	Brake drum w/studs
539 11 18-23	Plug
539 11 18-24	Foam strip



## PARTS DESCRIPTION

---

539 11 18-34	Muffler
539 11 18-35	Muffler, NA
539 11 18-43	Hose assembly
539 11 18-44	Washer, heavy
539 11 19-23	HCS, 5/8C X 3, GD5
539 11 19-24	Nut, 5/8C, centerlock, GR5
539 11 21-20	Hcs, 7/16-20, GD.8, SPEC.
539 20 01-00	Nut, 1/2-13, centerlock
539 30 05-99	Bolt, M6-1 x 40
539 30 06-00	Bolt, M8 x 1.25 x 20
539 91 22-22	Hose clamp
539 91 22-34	Air valve
539 91 27-58	Zerk, 90°
539 91 30-10	Decal, CPSC
539 91 70-33	Key, 1/4 sq. x 2 1/2
539 91 90-78	Pulley, idler
539 92 37-87	Bushing, machine, 7/8
539 97 68-56	Wire tie
539 97 69-34	HCS 5/16-18 X 3/4, GR5
539 97 69-38	Hcs, 5/16C x 2 1/4
539 97 69-52	Screw, #10-24 x 5/8
539 97 69-77	Nut, #10-24, nyloc
539 97 69-78	Nut, 1/4-20, nyloc
539 97 69-79	Nut, 3/8-16, nyloc
539 97 69-82	Washer, 5/8
539 97 69-89	Hairpin, #4
539 97 69-98	Zerk
539 97 73-26	Grease popet
539 97 74-65	Yoke
539 97 76-92	Bolt, M8-1.25 x 35
539 97 77-03	Pin, clevis
539 97 77-78	Pad, abrasive
539 99 00-52	Lockwasher, 1/4
539 99 01-18	Lockwasher, 3/8
539 99 01-22	Washer, 3/8, SAE
539 99 01-34	Bolt, 3/8-16 x 3/4
539 99 01-55	Nut, 3/8-24
539 99 01-84	Nut, 5/16-18, centerlock
539 99 01-87	Lockwasher, 5/16
539 99 01-88	Washer, 5/16, SAE
539 99 01-96	Nut, 5/16C
539 99 02-09	Bolt, 5/16-18 x 1, GD.5
539 99 02-23	Nut, 5/16-24
539 99 02-47	Lockwasher, 7/16
539 99 02-54	Lockwasher, 1/2
539 99 02-58	Nut, 1/2-13

# PARTS DESCRIPTION

---

539 99 02-97	Cotter pin
539 99 03-33	Lockwasher, 5/8
539 99 03-62	Screw, 1/4-20 x 5/8, self-tapping
539 99 03-65	Pin, cotter, 1/8 x 3/4
539 99 04-11	Bolt, #10-24 x 1/2
539 99 05-17	Washer, 3/8
539 99 05-46	Nut, 3/8-16, centerlock
539 99 05-48	Bolt, 1/4-20 x 1
539 99 05-50	Washer, 1/2
539 99 05-63	Bolt, 3/8-16 x 1
539 99 05-80	Bolt, 1/4-20 x 3/4
539 99 05-82	Bolt, 3/8-16 x 1, ser.
539 99 05-85	Nut, 5/16-18, serrated washer
539 99 05-98	Washer, 1/4
539 99 06-13	Nut, 3/8-16, serrated washer
539 99 06-22	Bolt, 1/2-13 x 1 1/4, serrated head
539 99 06-27	Hcs, 5/16-18 x 1 1/4, GD.5
539 99 06-29	Bolt, 3/8-16 x 2 1/4
539 99 06-37	Bolt, 3/8-16 x 2 1/2
539 99 06-54	Pin, cotter, 5/32 x 1 1/4
539 99 06-55	Bolt 3/8-16 x 1 1/2
539 99 07-17	Nut, 5/16-18, nyloc
539 99 07-30	Bolt, 3/8-16 x 1 3/4
539 99 07-61	Nut, 1/4-20, centerlock
539 99 08-39	Nut, 7/16-14, centerlock
539 99 08-70	Ring, retaining
539 99 10-43	Bushing, machine, 5/8
539 99 10-46	Bolt, 5/16-18 x 2 1/2
539 99 10-50	Bushing, machine, 3/4
539 99 10-73	Nut, 5/16-24, jam, LH
539 99 11-20	Bolt, 7/16-20 x 2 1/2



