

Poulan PRO®



PZ4822

Parts manual

Please read the operator's manual carefully and make sure you understand the instructions before using the machine.

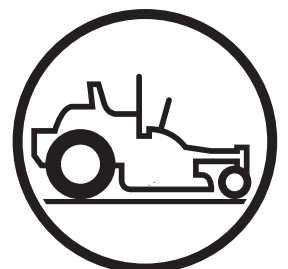

English

CONTENTS

MAIN FRAME	2-3
ENGINE ASSEMBLY	4
CASTER ASSEMBLY	5
CONSOLE ASSEMBLY	6
48" DECK ASSEMBLY	7
EZT	8
MOTION CONTROL	9
DECK LIFT	10
DECALS	11
ACCESSORIES	12
WIRING SCHEMATIC	13
PARTS DESCRIPTION	14-18

MAIN FRAME

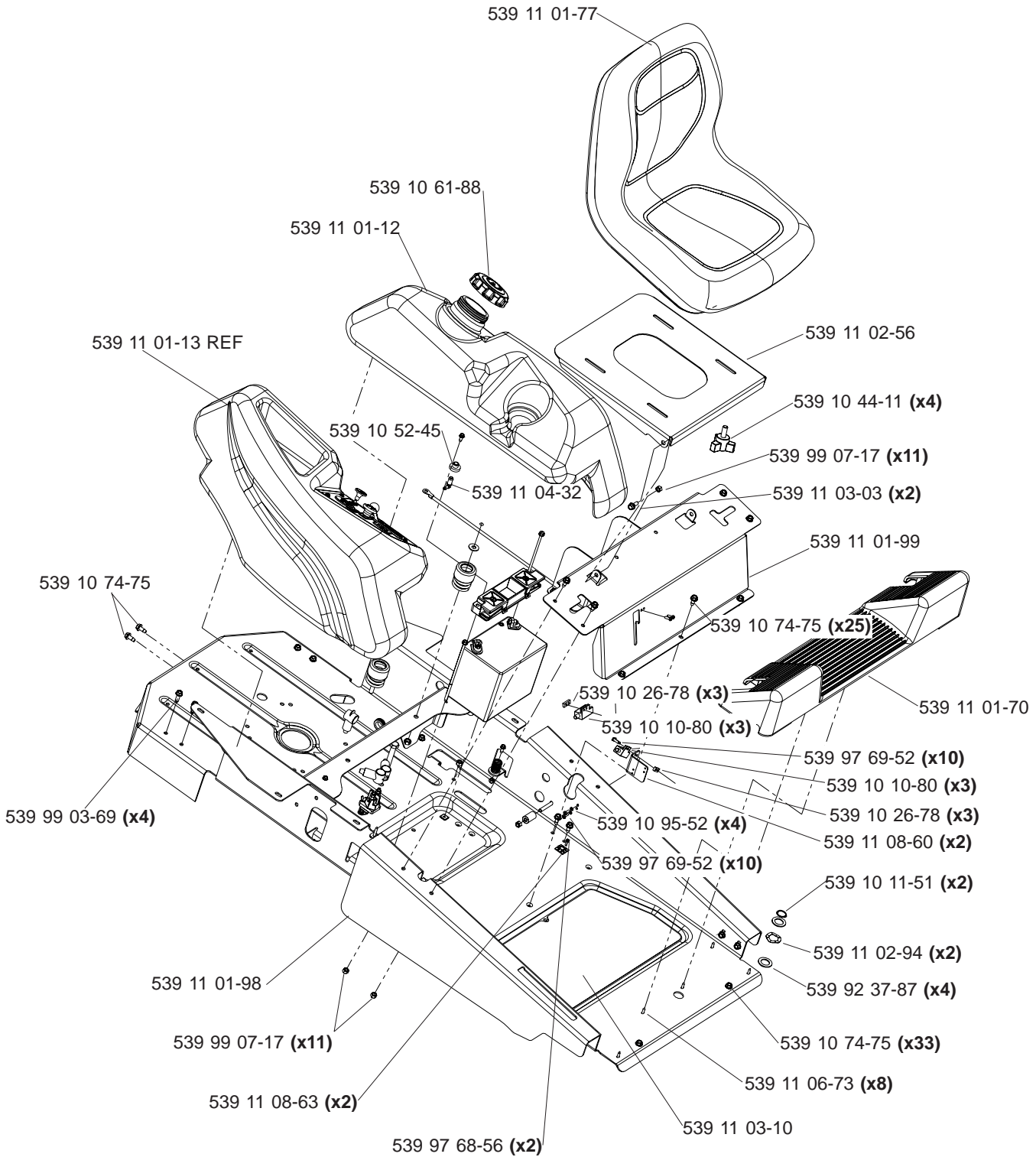

NOT SHOWN:

- 539 10 75-23 SEAT SWITCH
- 539 10 76-16 BATTERY CABLE, POSITIVE
- 539 11 00-68 BATTERY CABLE, NEGATIVE
- 539 11 03-09 WIRE HARNESS

MAIN FRAME

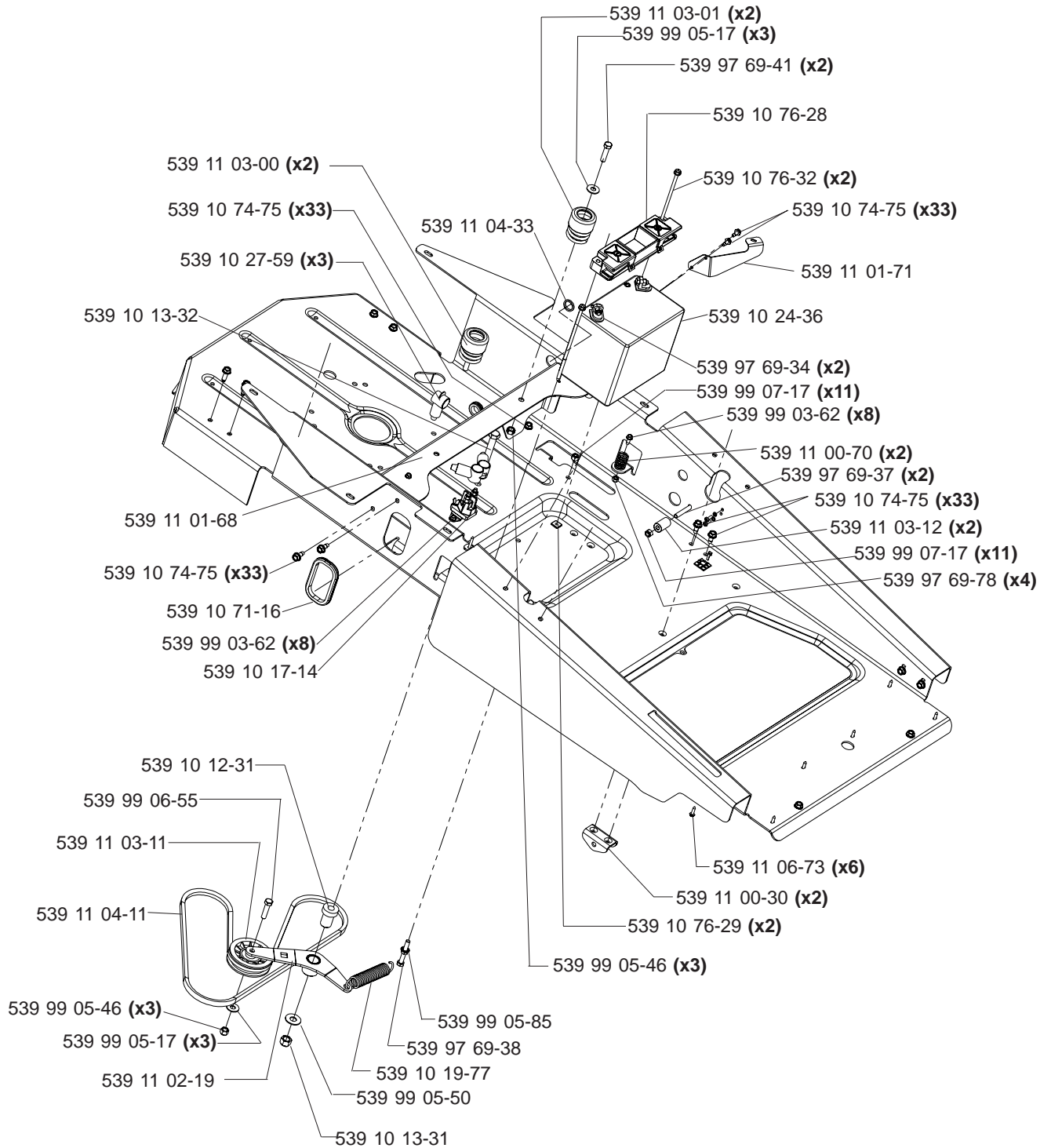

ENGINE ASSEMBLY (22 HP)

BRIGGS & STRATTON

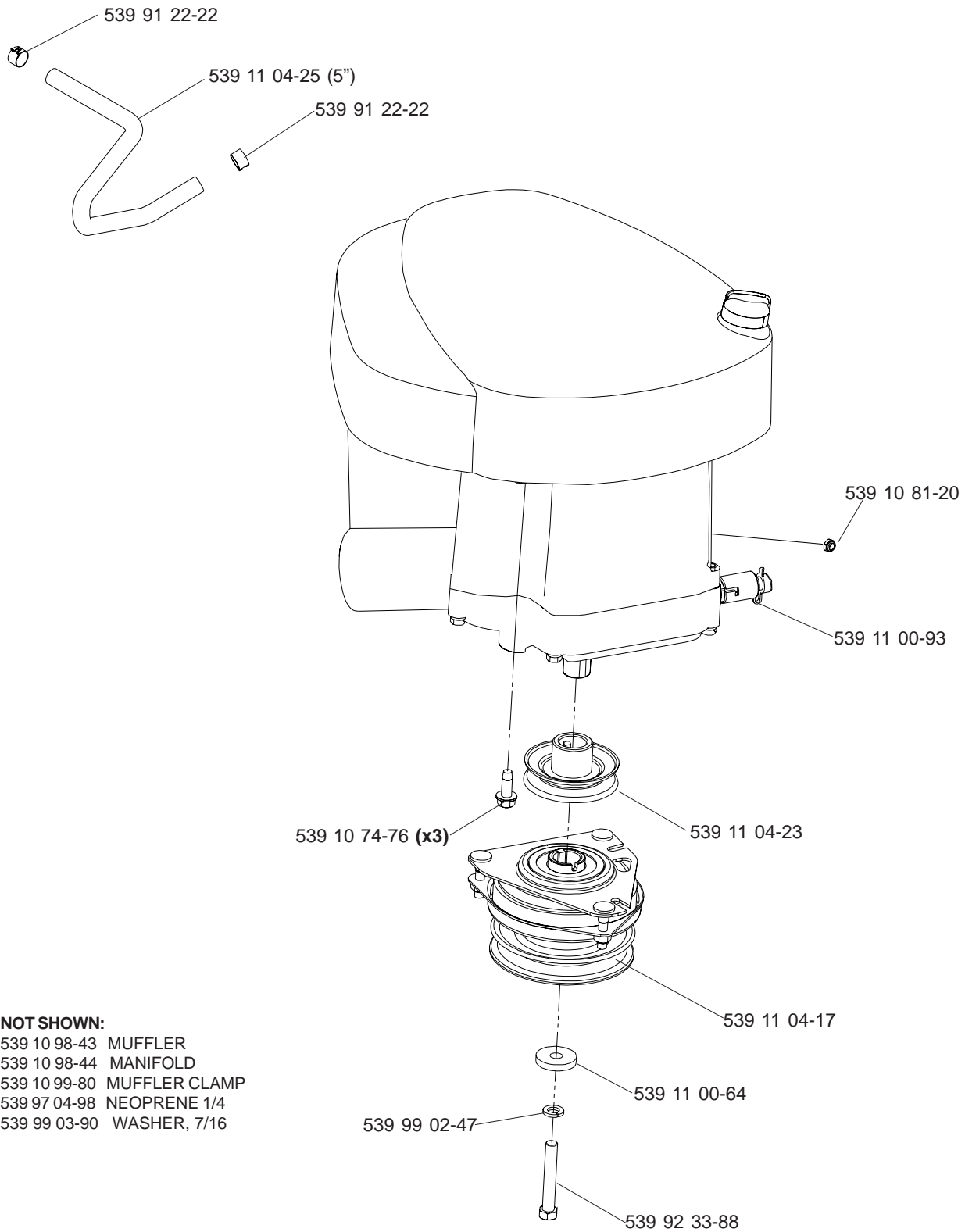

CASTER ASSEMBLY

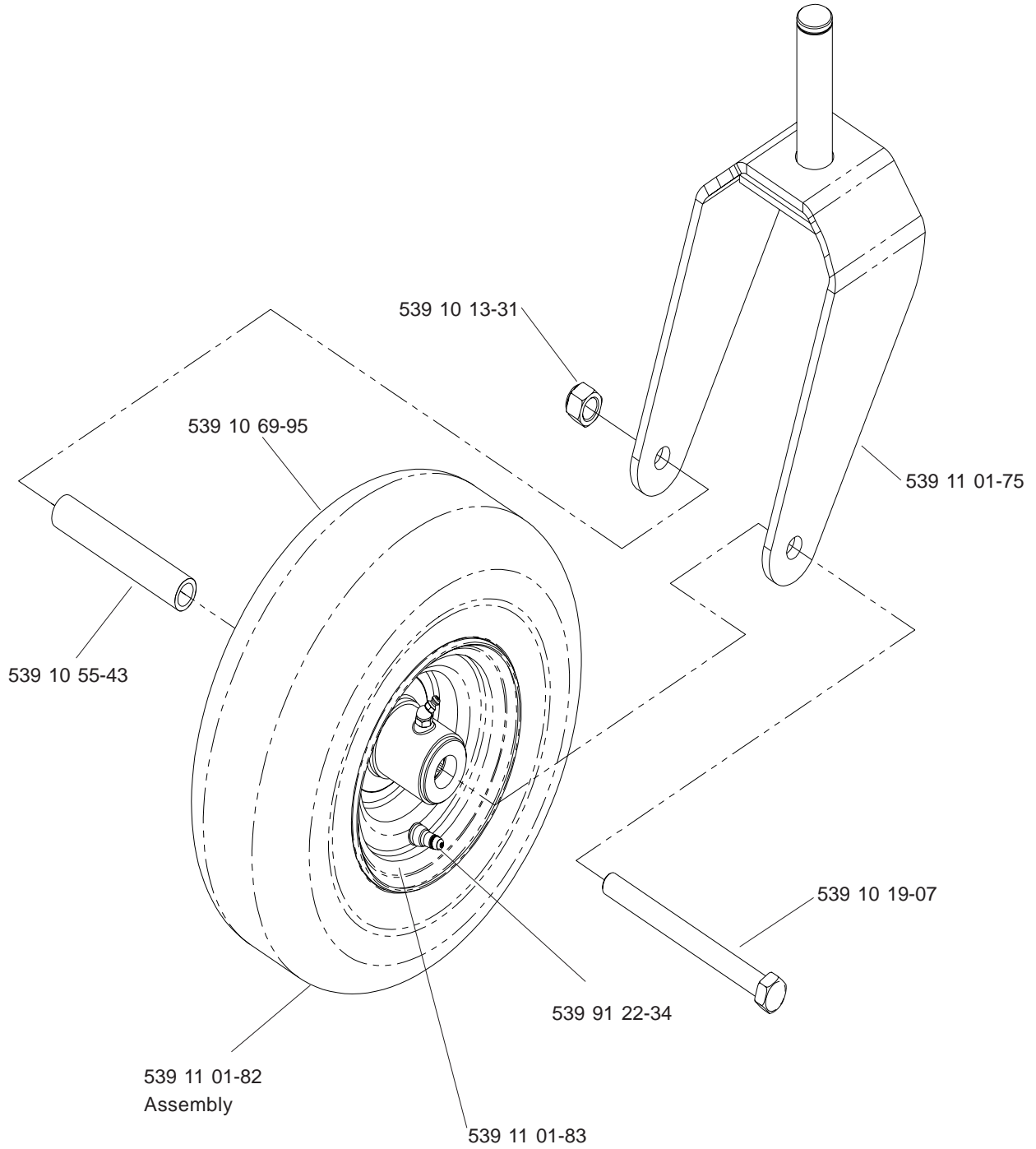

CONSOLE ASSEMBLY

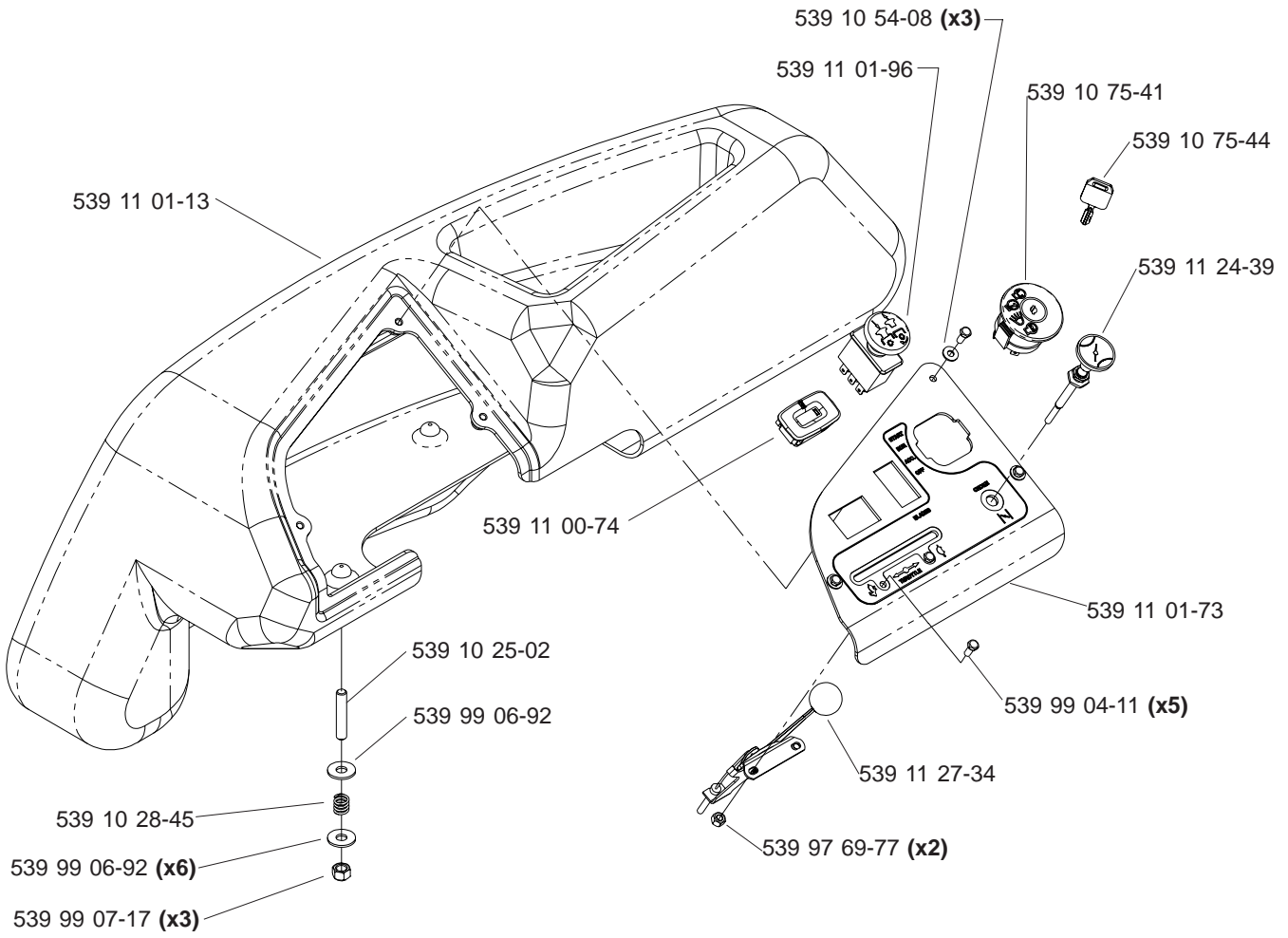

EZT

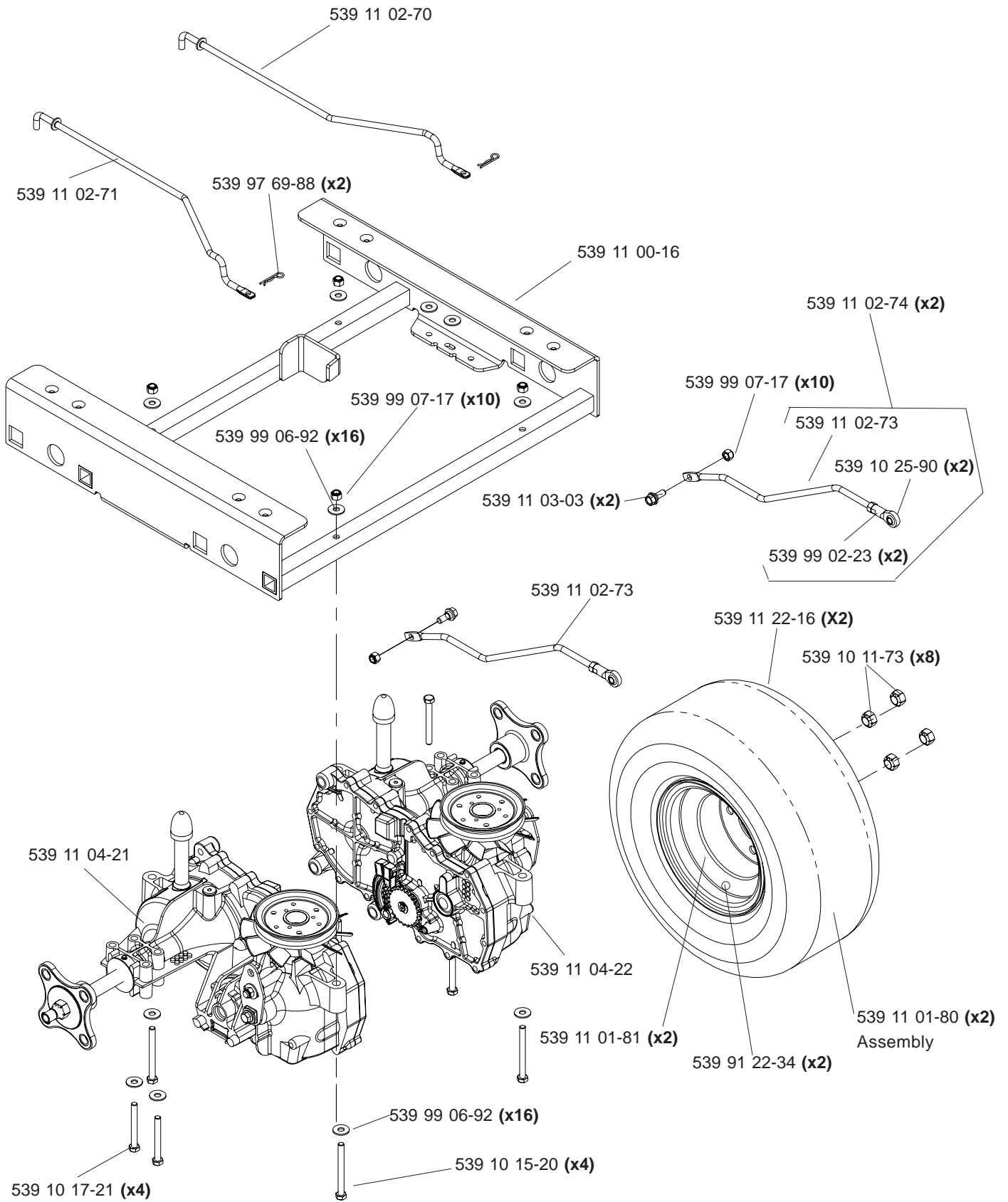

MOTION CONTROL

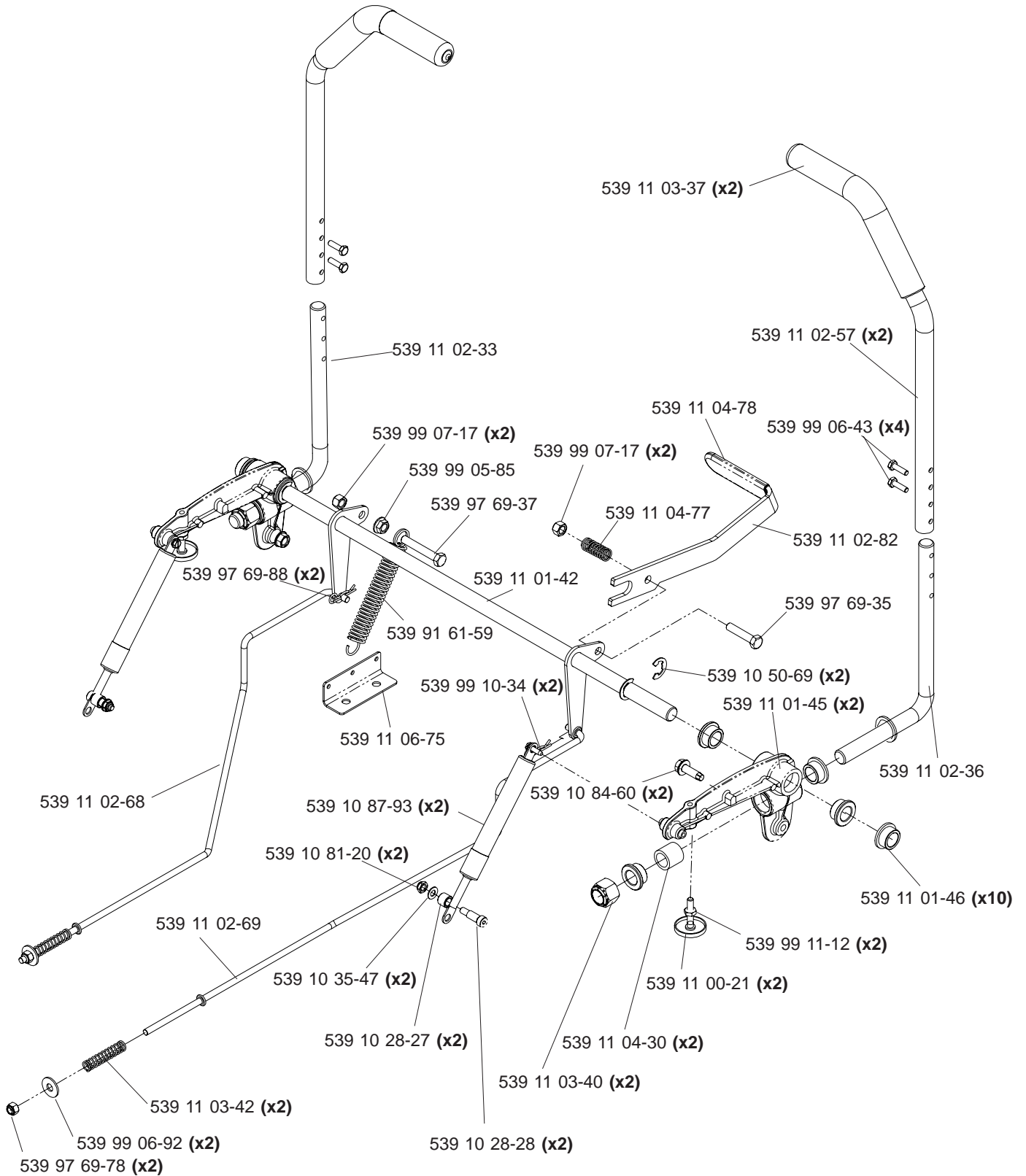

DECK LIFT

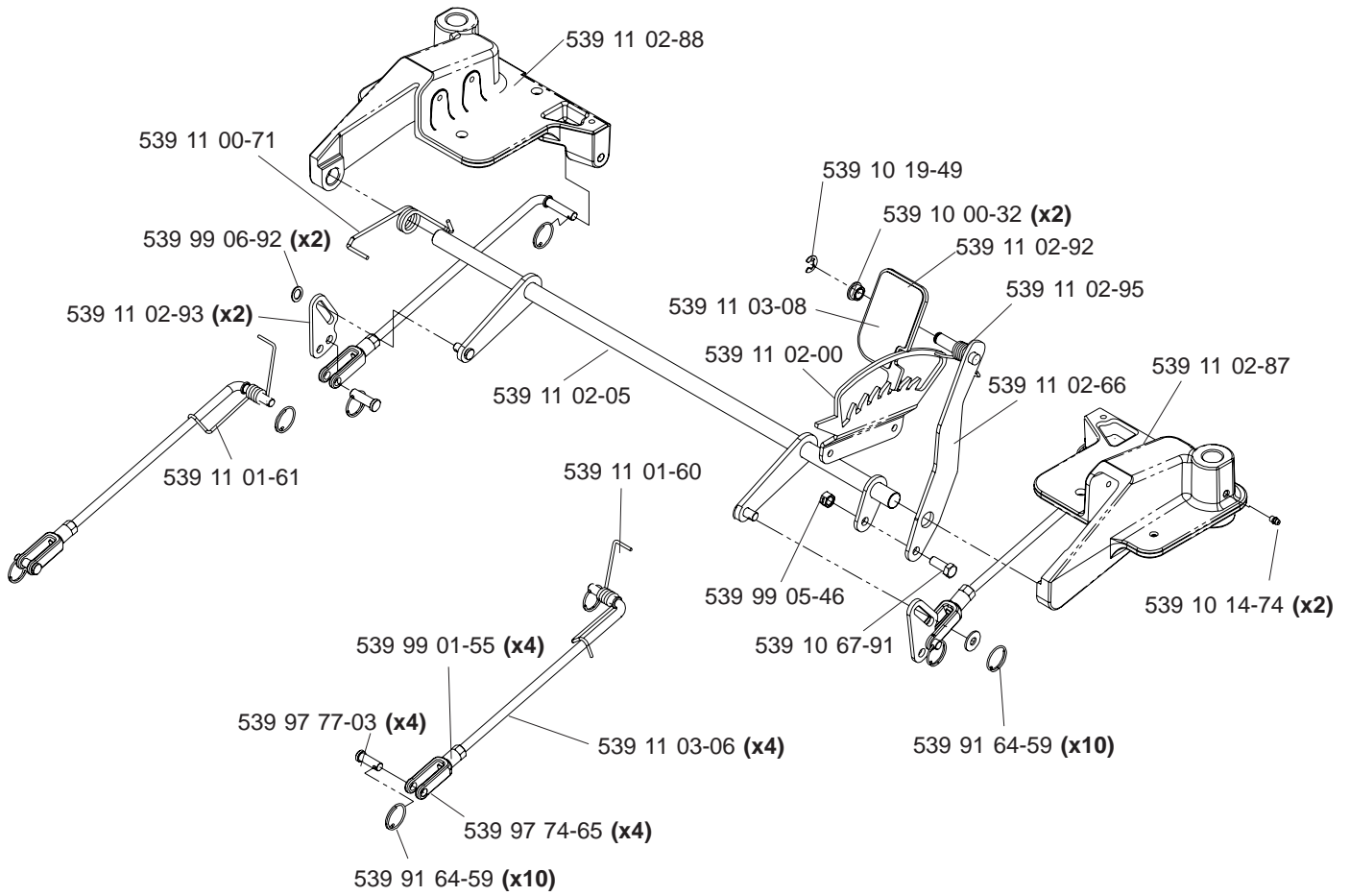

DECALS

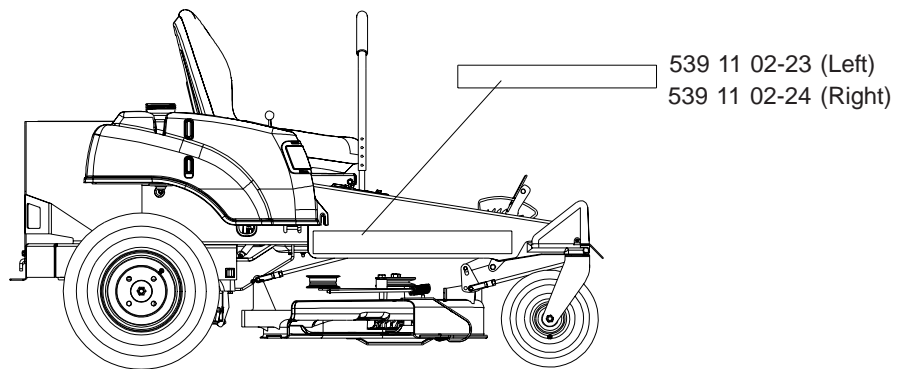
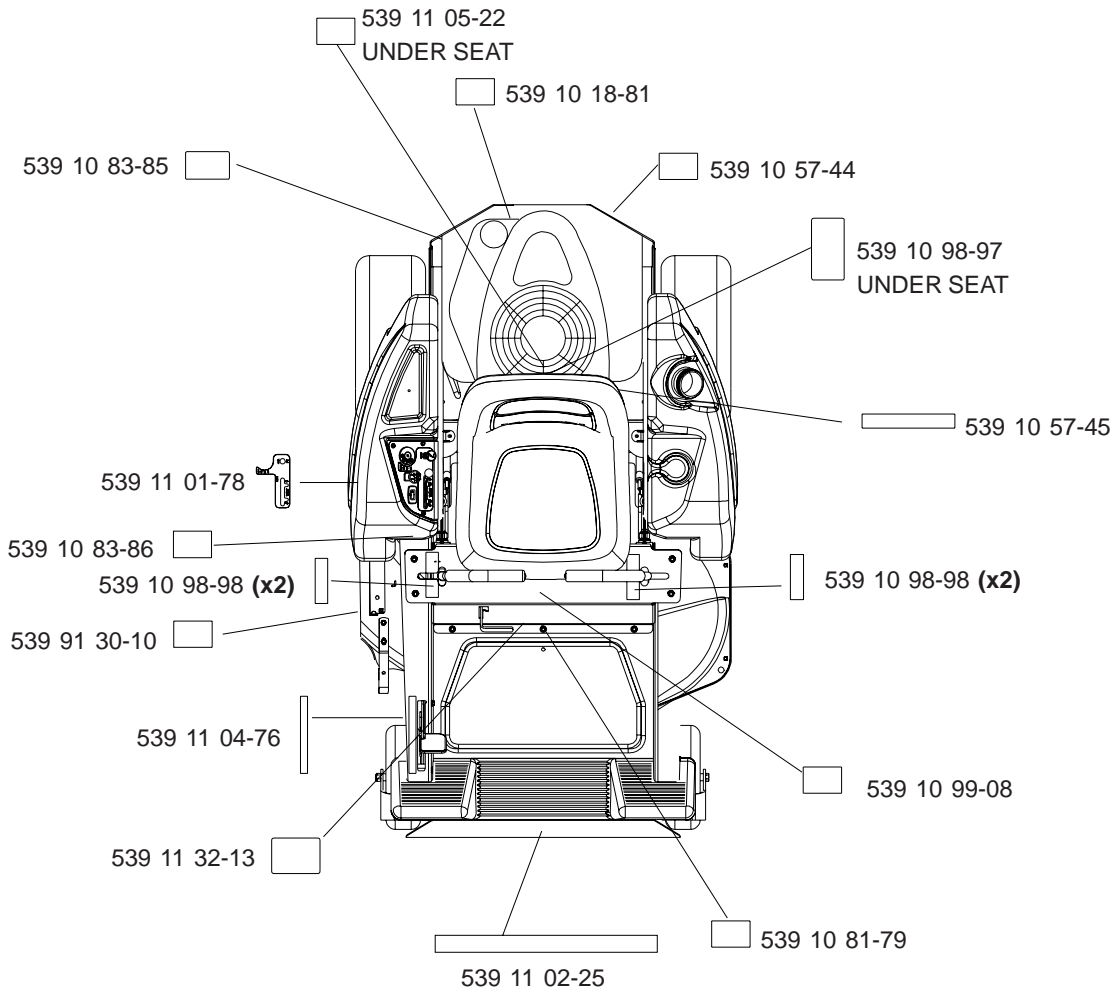

ACCESSORIES

PART NO.	QTY.	DESCRIPTION
539 11 04-69.....	1	KIT, ARMREST

WIRING SCHEMATIC

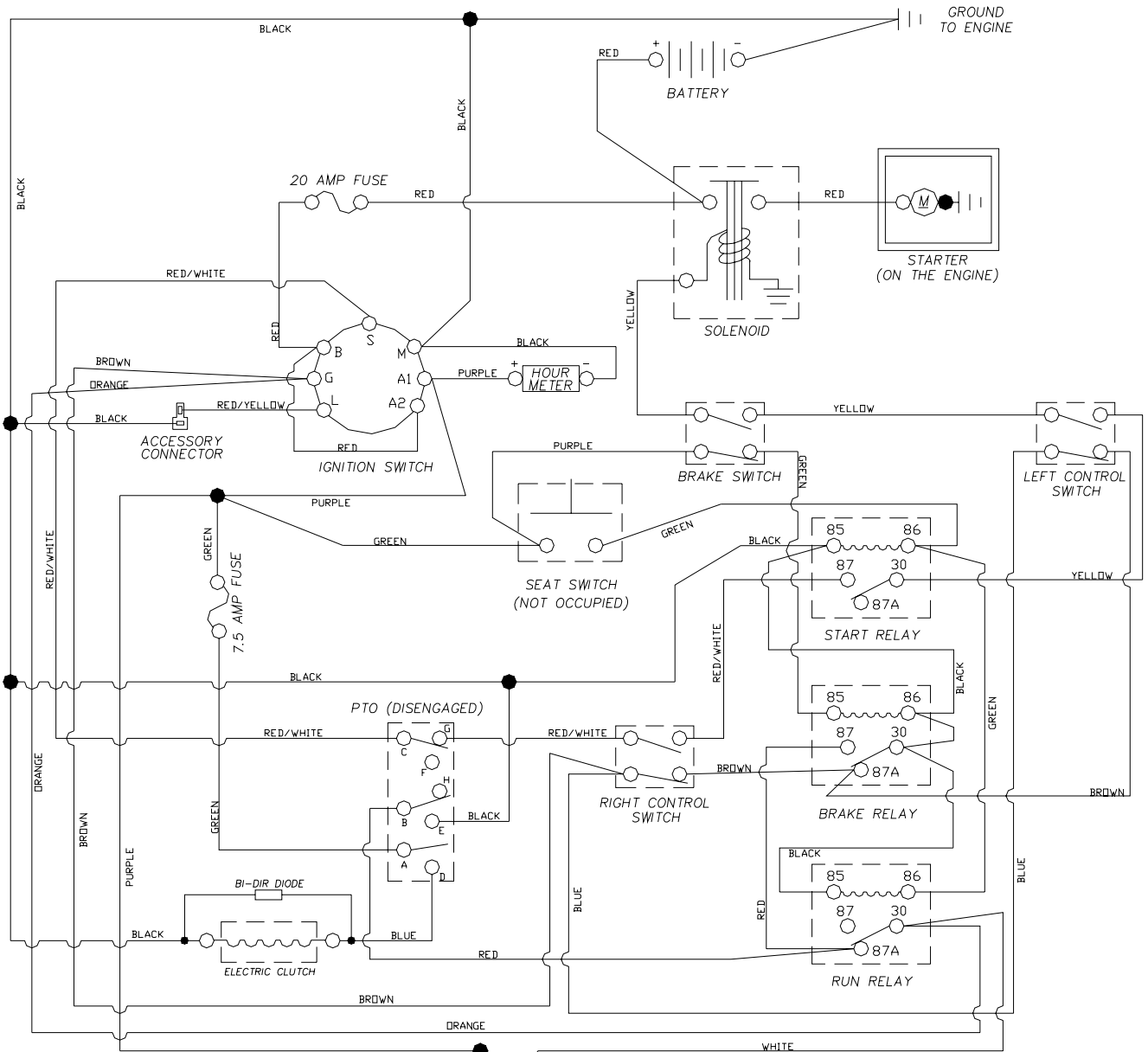

PTO SWITCH

POSITION	CIRCUIT
OFF	C + G, B + H
ON	C + F, B + E, A + D

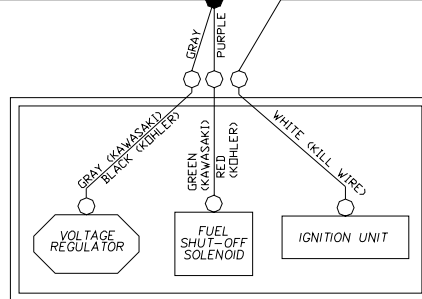
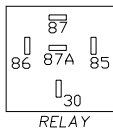

NON-REMOVABLE CONNECTIONS

REMOVABLE CONNECTIONS

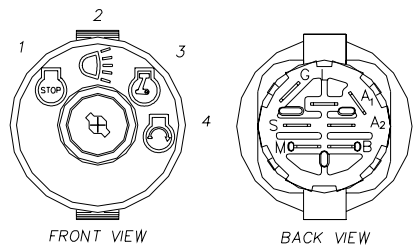

IGNITION SWITCH

POSITION	FUNCTION	CONTACT 1	CONTACT 2
1	OFF	M+G+A ₁	NONE
2	ON+ASS.	B+A ₁	L+A ₂
3	ON	B+A ₁	NONE
4	START	B+S+A ₁	NONE

Parts Descriptions

539 10 00-32	BUSHING, NYLON FLANGED
539 10 10-80	SWITCH N.C.
539 10 11-51	RETAINING RING
539 10 11-73	NUTS, LUG
539 10 12-31	IDLER SPINDLE
539 10 13-31	NUT, 1/2C, NYLOC
539 10 13-32	HCS, 1/2-13 X 2 3/4, GR5
539 10 14-74	ZERK
539 10 15-20	HCS, 5/16-18 X 3 1/4, GR5
539 10 15-72	HCS, 1/2C X 3
539 10 17-14	SOLENOID
539 10 17-21	HCS, 5/16-18 X 2 3/4, GR5
539 10 18-81	DECAL, PROP 65
539 10 19-07	HCS 1/2-13 X 5 1/2
539 10 19-49	E-RING, 1/2"
539 10 19-77	TRACTION SPRING
539 10 22-43	WASHER, SUPPORT
539 10 24-36	BATTERY 12V
539 10 25-02	TANK-STUD FUEL
539 10 25-90	BALL END, R.H.
539 10 26-12	HCS, 3/8C X 2 3/4
539 10 26-78	PLATE, SWITCH, THREAD FORM
539 10 27-59	INSULATOR
539 10 28-27	SPACER, PULLEY
539 10 28-28	BOLT, 5/16 X 5/8, SHOULDER
539 10 28-45	SPRING-FUEL TANK
539 10 32-57	IDLER PULLEY
539 10 32-95	IDLER BUSHING
539 10 35-47	WASHER, 1/4
539 10 44-11	KNOB W/STUD
539 10 50-69	E-RING, 5/8
539 10 52-45	GROMMET, RUBBER
539 10 54-08	WASHER #10 FLAT Zd
539 10 55-43	SPACER
539 10 57-44	DECAL, EURO DANGER BELT
539 10 57-45	DECAL, EURO BATTERY WARNING
539 10 61-88	FUEL CAP
539 10 67-91	HCS 3/8-16 X 1, GR8
539 10 69-95	TIRE
539 10 71-16	GROMMET
539 10 74-75	BOLT, 5/16-18 X 3/4, THREAD FORMING
539 10 74-76	BOLT, 3/8-16 X 1, THREAD FORMING
539 10 75-15	CUTTER HOUSING ASM, INCLUDES: BALL BEARINGS, MANDREL ASM, SHAFT ASSM W/LOWER BEARING
539 10 75-18	STRIPPER, ROUND, UNIVERSAL
539 10 75-19	BLADE, HIGH LIFT
539 10 75-20	WASHER-SPACER
539 10 75-21	PULLEY

Parts Descriptions

539 10 75-22	BOLT, 7/16, ASSY BLADE
539 10 75-23	SEAT SWITCH
539 10 75-41	IGNITION SWITCH
539 10 75-44	KEY
539 10 75-90	NUT, 9/16, TOP CENTER LOCK
539 10 76-04	DISCHARGE CHUTE
539 10 76-08	BOLT, SHOULDER
539 10 76-09	SPRING, TORSION
539 10 76-10	WHEEL, GAUGE
539 10 76-12	ROLLER, NOSE, 48"
539 10 76-13	ROD, ROLLER, NOSE, NARROW
539 10 76-14	BAFFLE, VORTEX, MOWER
539 10 76-16	BATTERY CABLE, POSITIVE (NOT SHOWN)
539 10 76-17	BUSHING, PIVOT, TENSION RELIEF
539 10 76-20	PULLEY, IDLER
539 10 76-26	PUSHNUT
539 10 76-27	CAP-SLEEVE
539 10 76-28	BATTERY HOLD DOWN
539 10 76-29	PUSH NUT, NYLON
539 10 76-30	SCREW, WASHER HEAD
539 10 76-31	SCREW, 1/4-20 X 5/8, THDROLL
539 10 76-32	BOLT, 1/4 X 7 1/2
539 10 78-03	TENSION RELIEF LINKAGE
539 10 81-20	NUT, 1/4C, THIN NYLOC
539 10 81-79	DECAL, START
539 10 83-85	DECAL, DO NOT TOW
539 10 83-86	DECAL, EXITING MOWER
539 10 84-60	BOLT, 5/16-18 X 1 1/4, THREAD FORM
539 10 86-68	TENSION RELIEF LEVER
539 10 87-93	DAMPENER
539 10-88-83	SWIVEL
539 10 92-43	DECK BELT
539 10 95-52	LOCKWASHER, 3/16
539 10 95-82	SUPPORT PLATE
539 10 97-80	DECK IDLER ARM WLDMT.
539 10 98-43	MUFFLER
539 10 98-44	MANIFOLD
539 10 98-97	DECAL, SERVICE
539 10 98-98	DECAL, MOTION CONTROL
539 10 99-08	DECAL, SAFETY WARNING
539 10 99-80	MUFFLER CLAMP
539 11 00-16	SUB FRAME
539 11 00-21	POST, NEUTRAL RETURN
539 11 00-25	BOLT, 3/8-16 X 1 1/2, THREAD FORMING
539 11 00-30	BRACKET, DECK HANGER
539 11 00-64	CLUTCH WASHER
539 11 00-68	BATTERY CABLE, NEGATIVE (NOT SHOWN)
539 11 00-70	SPRING, NEUTRAL RETURN

Parts Descriptions

539 11 00-71	TORSION SPRING, DECK LIFT
539 11 00-74	HOURMETER
539 11 00-93	PLUG, EZ OIL DRAIN
539 11 01-12	TANK,FUEL
539 11 01-13	FENDER,CONSOLE
539 11 01-14	BELT SHIELD
539 11 01-42	SHAFT, MOTION, BRAKE ASS'Y
539 11 01-45	MOTION CASTING
539 11 01-46	MOTION BUSHING
539 11 01-60	SPRING, DECK ROD, RIGHT
539 11 01-61	SPRING, DECK ROD, LEFT
539 11 01-68	REAR SEAT SUPPORT
539 11 01-70	FOOTREST
539 11 01-71	TANK SUPPORT
539 11 01-73	CONSOLE PLATE
539 11 01-75	CASTER
539 11 01-77	SEAT
539 11 01-78	DECAL,CONTROLS
539 11 01-80	TIRE ASM, 18 X 9.50 - 8
539 11 01-81	RIM
539 11 01-82	TIRE,COMPLETE
539 11 01-83	RIM
539 11 01-96	SWITCH
539 11 01-97	DECK W/ DECALS
539 11 01-98	FRAME,CHASSIS
539 11 01-99	SEAT SUPPORT W/DECALS
539 11 02-00	DECK HEIGHT ADJUSTOR
539 11 02-05	DECK LIFTER
539 11 02-19	IDLER ARM, PUMP
539 11 02-23	DECAL,POULAN PRO,LH
539 11 02-24	DECAL,POULAN PRO,RH
539 11 02-25	DECAL,POULAN PRO,NOSE
539 11 02-33	MOTION ARM, LEFT
539 11 02-36	MOTION ARM, RIGHT
539 11 02-56	SEAT PLATE
539 11 02-57	CONTROL LEVER, PAINTED
539 11 02-66	FOOTLEVER
539 11 02-68	BRAKE ROD, RIGHT
539 11 02-69	BRAKE ROD, LEFT
539 11 02-70	BYPASS LINKAGE, LEFT
539 11 02-71	BYPASS LINKAGE, RIGHT
539 11 02-73	MOTION ROD (COMPLETE)
539 11 02-74	MOTION ROD
539 11 02-82	UPPER BRAKE LEVER

Parts Descriptions

539 11 02-87	STEERING CASTER, RIGHT
539 11 02-88	STEERING CASTER, LEFT
539 11 02-92	FOOT PEDAL
539 11 02-93	DECK LIFT CONNECTOR
539 11 02-94	WAVE WASHER
539 11 02-95	SPRING, PEDAL, LIFT
539 11 03-00	SPRING, SEAT
539 11 03-01	CAP, SPRING COVER
539 11 03-03	BOLT, 5/16, SHOULDER
539 11 03-06	DECK ROD
539 11 03-08	FOOT PAD, NON-SLIP
539 11 03-09	WIRING HARNESS (NOT SHOWN)
539 11 03-10	NON-SLIP MATTING
539 11 03-11	PULLEY, IDLER
539 11 03-12	MOTION LIMITER
539 11 03-37	CUSHION, CONTROL LEVER
539 11 03-38	CONTROL LEVER
539 11 03-40	NUT 5/8-11 NYLOC
539 11 03-42	SPRING, ROD BRAKE
539 11 04-11	BELT, HYDRO
539 11 04-17	CLUTCH
539 11 04-21	EZT, RIGHT
539 11 04-22	EZT, LEFT
539 11 04-23	PULLEY, ENGINE, BRIGGS
539 11 04-25	FUEL LINE, 5"
539 11 04-30	BUSHING, ELASTOMER
539 11 04-32	ELBOW, TANK
539 11 04-33	GROMMET, FUEL LINE
539 11 04-62	ROD, HINGE
539 11 04-69	KIT, ARMREST
539 11 04-76	DECAL, CUTTING HEIGHT
539 11 04-77	SPRING, BRAKE LEVER
539 11 04-78	GRIP, PARK BRAKE
539 11 05-22	DECAL, CUSTOMER RESPONSIBILITY
539 11 06-73	SCREW, 10-12 X 3/4, WASHER HEAD
539 11 06-74	SCREW #10-12x3/4 HEX WAS HD ZD
539 11 06-75	SPRING BRACKET
539 11 08-60	BRACKET
539 11 08-63	MOUNTING BLOCK, CABLE TIE
539 11 22-16	WHEEL ASM
539 11 24-39	CHOKE CABLE
539 11 27-32	DECAL, BELT ROUTING
539 11 27-34	THROTTLE CABLE
539 11 32-13	DECAL,WARNING

Parts Descriptions

539 91 22-22	CLAMP, HOSE
539 91 22-34	VALVE STEM
539 91 30-10	DECAL, CPSC
539 91 61-59	SPRING
539 91 64-59	RETAINER, RING
539 92 33-88	HCS, 7/16-20 X 3
539 92 37-87	MACHINE BUSHING, 7/8
539 97 04-98	NEOPRENE 1/4
539 97 68-56	WIRE TIE
539 97 69-34	HCS, 5/16-18 X 3/4
539 97 69-35	HCS 5/16-18 X 1 1/2, GR5
539 97 69-37	HCS 5/16-18 X 2 GR5
539 97 69-38	HCS, 5/16-18 X 2 1/4,
539 97 69-41	HCS, 3/8-16 X 1 1/4,
539 97 69-52	SCREW, 10-24 X 5/8, SPEC.
539 97 69-77	NUT, #10-24, HEX NYLON RING
539 97 69-78	NUT, 1/4C, NYLOC
539 97 69-79	NUT, 3/8C, NYLOC
539 97 69-88	PIN, HAIR
539 97 74-65	YOKE, 3/8F
539 97 77-03	PIN, CLEVIS
539 99 01-22	WASHER, 3/8, SAE
539 99 01-55	NUT, 3/8F
539 99 01-96	NUT 5/16-18 HEX ZD
539 99 02-08	RHSNB, 5/16C X 1
539 99 02-23	NUT, 5/16F
539 99 02-47	LOCKWASHER, 7/16
539 99 03-62	SCREW, 1/4C X 5/8, SELF TAPPING
539 99 03-65	COTTER PIN
539 99 03-69	SCREW, 5/16 X 1, TAPTITE
539 99 03-90	WASHER, 3/8
539 99 04-11	HCS, #10-24 X 1/2
539 99 05-17	WASHER, 3/8
539 99 05-46	NUT, 3/8C, CENTERLOCK
539 99 05-50	WASHER, 1/2
539 99 05-82	HCS, 3/8C X 1, SERRATED HEAD
539 99 05-85	NUT, 5/16-18 WHIZLK
539 99 06-43	HCS 1/4-20 X 7/8, GR5
539 99 06-55	HCS, 3/8-16 X 1 1/2, GR5
539 99 06-92	WASHER, 5/16
539 99 07-17	NUT, 5/16C, NYLOC
539 99 07-30	HCS, 3/8C, 1 3/4
539 99 07-99	RHSNB, 5/16-18 X 5/8, GR5
539 99 10-34	SCREW, 10-24 X 5/8, WASHER
539 99 11-12	NUT, 1/4-20, JAM

