

Operator's manual
WG4815P/968999278
WG3613P/968999116
WG3213P/968999114

Please read the operator's manual carefully and make sure you understand the instructions before using the machine.

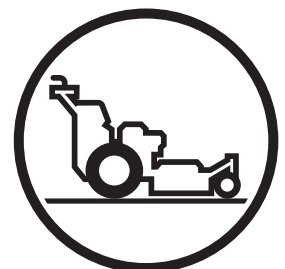

English

OPERATOR'S MANUAL

MOWER

WG3213P WG3613P WG4815P

Contents

Contents	1	Maintenance	35
Introduction	3	Maintenance Schedule.....	35
Congratulations.....	3	Ignition System.....	37
General	3	Checking the Safety System	38
Driving and Transport on Public Roads	3	Checking the Engine's Cooling Air Intake	38
Towing	3	Checking and Adjusting the Throttle Cable and the	
Operating	3	Choke Cable	39
Good Service	4	Kawasaki Engine Air Filter	40
Manufacturing Number	4	Kohler Engine Air Filter	41
Symbols and Decals	5	Replacing the Fuel Filter	42
Safety Instructions	7	Checking the Fuel Pump's Air Filter	42
General Use.....	7	Checking Tire Pressures.....	42
Driving on Slopes.....	9	Checking the Parking Brake.....	43
Children.....	10	Checking the V-belts	43
Maintenance	11	Checking the Blades	44
Transport.....	13	Brake rod adjustment	44
Customer responsibilities	13	Under side of rear deck.....	44
Controls	14	Cleaning and Washing	45
Control Locations	14	Caster Wheels.....	45
1. Recoil Starter Grip	15	Hardware.....	45
2. Ignition Switch.....	15	Blade replacement	46
3. Motion control levers.....	16	Lubrication	47
4. Operator Presence Lever.....	16	Lubrication Schedule.....	47
5. Choke and Throttle Control.....	17	General	47
6. Gear Shift Lever	17	Lubricating the Cables	48
7. Thumb Latch	18	Lubricating in Accordance with the Lubrication	
8. Blade Engagement Lever	18	Schedule	48
9. Refueling.....	19	Trouble Shooting Guide	57
10. Fuel Shut-off Valve	20	Storage	59
Accessories.....	20	Winter Storage	59
Operation	21	Service	59
Before Starting	21	Technical data	60
Starting the Engine	22	Torque Specifications.....	62
Gearbox	25	Wiring diagram	63
Running.....	25	Conformity Certificates	64
Reversing.....	26	USA requirements.....	64
To operate on hills	26	Service Journal	65
Mowing Tips	27	Delivery Service	65
Stopping.....	29	After the First 8 Hours	65
Stopping the Engine.....	30	25-Hour Service	66
Adjustment of cutting height.....	31	50-Hour Service	67
Moving Machine by Hand	34	100-Hour Service	68
		300-Hour Service	69
		At Least Once Each Year.....	70



WARNING!

Failure to follow cautious operating practices can result in serious injury to the operator or other persons. The owner must understand these instructions, and must allow only trained persons who understand these instructions to operate the mower. Each person operating the mower must be of sound mind and body and must not be under the influence of any mind altering substance.



WARNING!

Engine exhaust, some of its constituents, and certain vehicle components contain or emit chemicals known to the State of California to cause cancer and birth defects or other reproductive harm.

INTRODUCTION

Introduction

Congratulations

Thank you for purchasing a Husqvarna Walk-Behind Mower. This machine is built for the greatest efficiency and rapid mowing primarily of large areas. Controls in one place and a transmission regulated by motion controls contribute to the machine's performance.

This manual is a valuable document. Following the instructions (use, service, maintenance, etc.) can considerably increase the lifespan of your machine and even increase its resale value.

If you sell your machine, be sure to give this Operator's Manual to the new owner.

The final chapter of this Operator's Manual comprises a Service Journal. Ensure that service and repair work is documented. A well kept service journal reduces service costs for the season-based maintenance and affects the machine's resale value. Take the Operator's Manual along when the machine is left to the workshop for service.

General

In this Operator's Manual, left and right, backward and forward are used in relation to the machine's normal driving direction.

Driving and Transport on Public Roads

Check applicable road traffic regulations before driving and transport on public roads. If the machine is transported, you should always use approved fastening equipment and ensure that the machine is well anchored.

Towing

Do not tow this machine, it may cause damage to the drive system.

Do not tow any trailers, etc. with this mower. They may jackknife or overturn causing damage to the mower and possibly serious injury to the operator.

Operating

This machine is constructed only for mowing grass on lawns and other free and level ground without obstacles such as stones, tree stubs, etc. The machine can also be used for other tasks when equipped with special accessories provided by the manufacturer, for which the operating instructions are provided in conjunction with delivery. All other types of use are incorrect. The manufacturer's directions concerning operation, maintenance, and repairs must be carefully followed.

Lawnmowers and all power equipment, can be potentially dangerous if used improperly. Safety requires good judgement, careful use in accordance with these instructions and common sense.

The machine must only be operated, maintained, and repaired by persons that are familiar with the machine's special characteristics and who are well versed in the safety instructions.

Accident prevention regulations, other general safety regulations, occupational safety rules, and traffic regulations must be followed without fail.

Unauthorized modifications to the design of the machine may absolve the manufacturer from liability for any resulting personal injury or property damage.

INTRODUCTION

Good Service

Husqvarna's products are sold all over the world and only in specialized retail stores with complete service. This ensures that you as a customer receive only the best support and service. Before the product is delivered, the machine has, for example, been inspected and adjusted by your retailer, see the certificate in the Service Journal in this Operator's Manual.

When you need spare parts or support in service questions, warranty issues, etc., please consult the following professional:

This Operator's Manual belongs to the machine with manufacturing number:	Engine	Transmission

Manufacturing Number

The machine's manufacturing number can be found on the printed plate of the rear part of the chassis. Stated on the plate, from the top are:

- The machine's type designation (I.D.).
- The manufacturer's type number (Model).
- The machine's serial number (Serial no.)

Please state the type designation and serial number when ordering spare parts.

The engine's manufacturing number is stated on a decal. This is placed on Kawasaki engines at the left side of the crankcase. The plate states:

- The engine's serial number (E/NO).
- The engine's type designation (Code).

On Kohler engines an Engine Identification decal is placed on the fan housing showing:

- Family.
- Type APP.
- Model no.
- Spec no.
- Serial no.

Please state these when ordering spare parts.

SYMBOLS AND DECALS

Symbols and Decals

These symbols are found on the machine and in the operator's manual. Study them carefully so that you know what they mean.

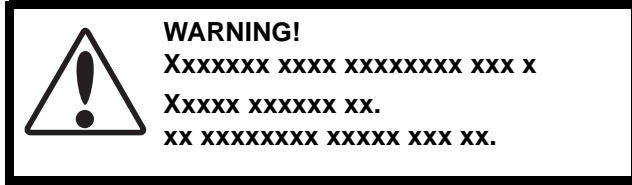

Used in this publication to notify the reader of a risk of **personal injury**, particularly if the reader should neglect to follow instructions given in the manual.

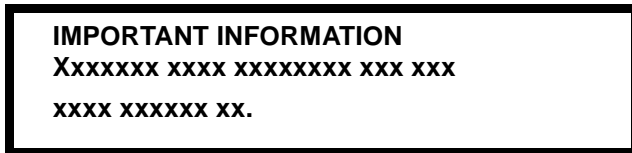

Used in this publication to notify the reader of a risk of **material damage**, particularly if the reader should neglect to follow instructions given in the manual. Used also when there is a potential for misuse or misassembly.



Warning!



Noise emissions to the surroundings in accordance with the European Union's directive. The machine's emission is stated in the chapter TECHNICAL DATA and on the decals..

Only machines for European market



Fast



Slow



Choke



Fuel



CE conformity marking



Warning! Rotating blades, keep away from the discharge deck



Do not touch rotating parts



Parking brake.



Use protective glasses



Use protective gloves



Do not stand here

SYMBOLS AND DECALS



Moving sharp blades under cover.

Keep a safe distance from the machine.

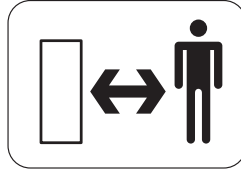

Severing of fingers & toes.

Read Operator's Manual.



Rotating blades.

Whole body exposure to thrown objects.

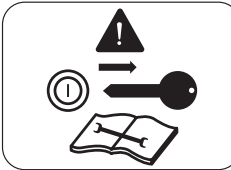
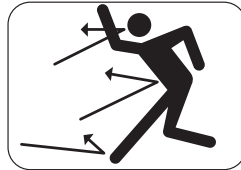

Shut off engine & remove key before performing any maintenance or repair work.

SAFETY INSTRUCTIONS

Safety Instructions

These instructions are for your safety. Read them carefully.



WARNING!

This symbol means that important safety instructions need to be emphasized. It concerns your safety.

General Use

- Read all instructions in this operator's manual and on the machine before starting it. Ensure that you understand them and then abide by them.
- Learn how to use the machine and its controls safely and learn how to stop quickly. Also learn to recognize the safety decals.
- Only allow the machine to be used by adults who are familiar with its use.
- Make sure nobody else is in the vicinity of the machine when you start the engine, engage the drive, or run the machine.
- Make sure animals and people maintain a safe distance from the machine.
- Stop the machine if someone enters the work area.
- Clear the area of objects such as stones, toys, steel wire, etc. that may become caught in the blades and thrown out before operating unit.
- Beware of the discharge deck and do not point it at any one. Do not use the machine without the discharge chute in place.
- Stop the engine and prevent it from starting before you clean the discharge deck.
- Remember that the operator is responsible for dangers or accidents.
- Never take passengers. The machine is only intended for use by one person.
- Always look down and behind before and during reversing maneuvers. Look out for both large and small obstacles.
- Slow down before turning.

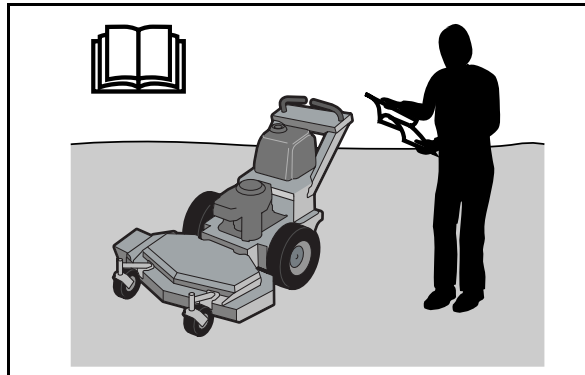

8011-630

Read the operator's manual before starting the machine

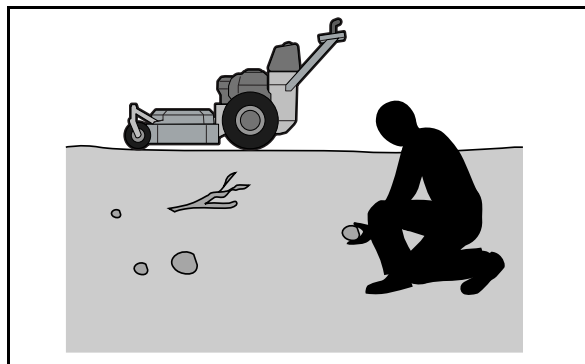

8011-631

Clear the area of objects before mowing

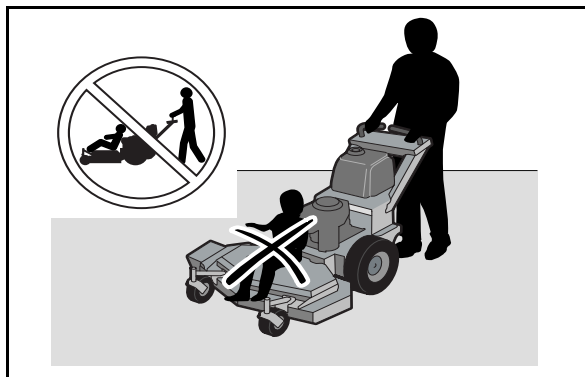

8011-632

Never take passengers

SAFETY INSTRUCTIONS

- Shut off the blades when not mowing.
- Be careful when turning around fixed objects, so that the blades do not hit them. Never drive over foreign objects.
- Only use the machine in daylight or in other well-lit conditions. Keep the machine a safe distance from holes or other irregularities. Pay attention to other possible risks.
- Never use the machine if you are tired, if you have consumed alcohol, or if you are taking other drugs or medication that can affect your vision, judgment, or coordination.
- Beware of traffic when working near or crossing a road.
- Never leave the machine unsupervised with the engine running. Always shut down the blades, engage the parking brake if so equipped, stop the engine, and remove the ignition key before leaving the machine.
- Never allow children or other persons not trained in the use of the machine to use or service it. Local laws may regulate the age of the user.



WARNING!

Engine exhaust and certain vehicle components contain or emit chemicals considered to cause cancer, birth defects, or other reproductive system damage. The engine exhaust contains carbon monoxide, which is a colorless, poisonous gas. Do not use the machine in enclosed spaces.



8011-633

Keep children away from the work area



WARNING!

When using the machine, approved personal protective equipment should be used. Personal protective equipment cannot eliminate the risk of injury but it will reduce the degree of injury if an accident does happen. Ask your retailer for help in choosing the right equipment.

- Make sure that you have first aid equipment close at hand when using the machine.
- Never use the machine when barefoot. Always wear protective shoes or boots, preferably with steel toecaps.
- Always wear approved protective glasses or a full visor when assembling or driving.
- Always wear gloves when handling the blades.
- Never wear loose clothing that can get caught in moving parts.
- Use ear protectors to avoid impaired hearing.

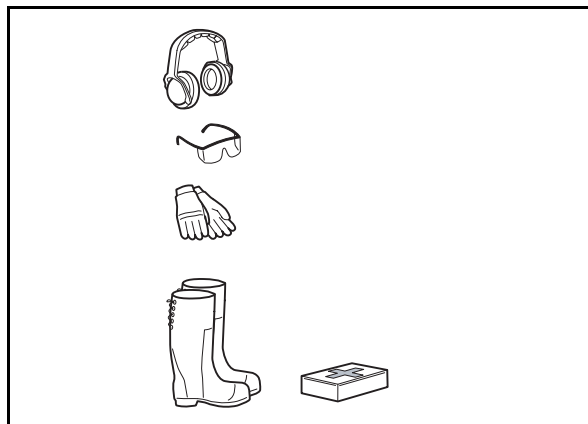

8011-670

Personal protective equipment

SAFETY INSTRUCTIONS

Driving on Slopes

Driving on slopes is one of the operations where the risk is greatest that the driver will lose control or the machine will tip over, which can result in serious injury or death. All slopes require extra caution. If you cannot reverse up a slope or if you feel unsure, do not mow the slope.

Do as follows

- Remove obstacles such as stones, tree branches, etc.
- Watch out for and avoid driving over furrows, holes, and bumps. On uneven terrain, the machine can tip more easily. Long grass can hide obstacles.
- Mow up and down, not side-to-side.
- If machine stops while going uphill, disengage blades and back down slowly.
- Drive evenly and slowly. Use small movements of the motion controls.
- Be extra cautious with any additional equipment, which can alter the machine's stability.

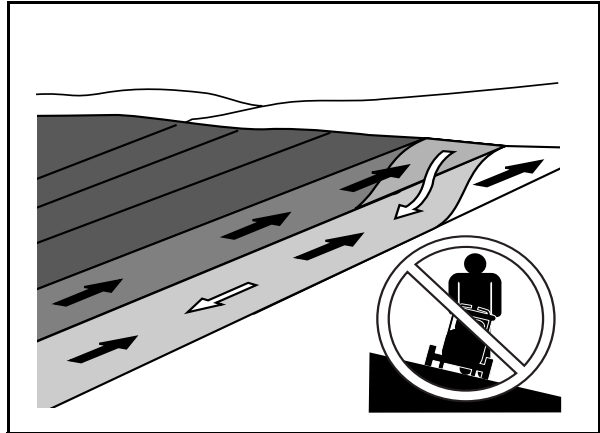

8011-634

Mow up and down, not side-to-side

Do not

- **Do not** make sudden changes in speed or direction.
- **Do not** drive the machine on terrain that slopes more than 10°.
- **Do not** mow near verges, ditches, or banks. The machine can suddenly spin around if a wheel goes over the edge of a drop or ditch, or if an edge gives way.
- **Do not** mow wet grass. It is slippery, and the tires can lose their grip, so that the machine slides.
- **Avoid** unnecessary turns on slopes, and if it proves necessary, turn slowly and gradually downward, if possible.
- **Avoid** starting or stopping on a slope. If the tires begin to slip, shut off the blades and drive slowly straight down the slope.

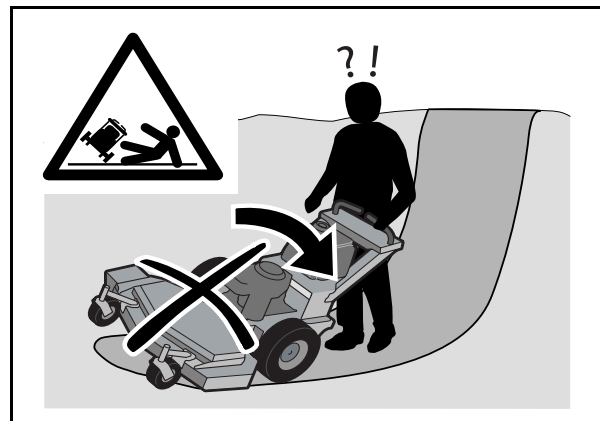

8011-635

Be extra cautious when driving on slopes

SAFETY INSTRUCTIONS

Children

- Serious accidents may occur if you fail to be on guard for children in the vicinity of the machine. Children are often attracted to the machine and mowing work. Never assume that children will stay where you last saw them.
- Keep children away from the mowing area and under close supervision by another adult.
- Keep an eye out and shut off the machine if children enter the work area.
- Before and during a reversing maneuver, look backward and downward for small children.
- Never allow a child to ride with you. They can fall off and injure themselves seriously or prevent risk-free maneuvering of the machine.
- Never allow children to operate the machine.
- Be particularly cautious near corners, bushes, trees, or other objects that block your view.

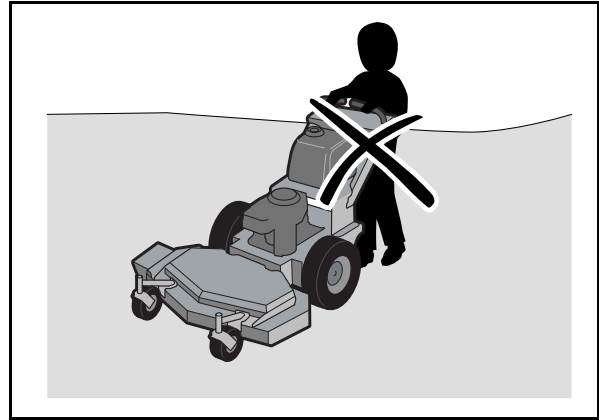

8011-636

Never allow children to operate the machine

SAFETY INSTRUCTIONS

Maintenance



WARNING!

The engine must not be started when the protective plate for the mower deck's drive belt is removed.

- Stop the engine. Prevent the engine from starting by removing the spark plug cables from the spark plugs or by removing the ignition key before making any adjustments or performing maintenance.
- Never fill the fuel tank indoors.
- Fuel and fuel fumes are poisonous and extremely flammable. Be especially cautious when handling fuel, as carelessness can result in personal injury or fire.
- Only store fuel in containers approved for the purpose.
- Never remove the fuel tank cap and never fill the fuel tank while the engine is running.
- Allow the engine to cool before refueling. Do not smoke. Do not fill fuel in the vicinity of sparks or open flames.
- If leaks arise in the fuel system, the engine must not be started until the problem has been resolved.
- Store the machine and fuel in such a way that there is no risk of leaking fuel or fuel vapor leading to damages.
- Check the fuel level before each use and leave space for the fuel to expand, because the heat from the engine and the sun may otherwise cause the fuel to expand and overflow.
- Avoid overfilling. If you spill fuel on the machine, wipe up the spill and wait until it has evaporated before starting the engine. If you have spilled fuel on your clothing, change your clothing.
- Allow the machine to cool before taking any actions in the engine compartment.
- Ensure that nuts and bolts, especially the fastening bolts for the blade attachments, are properly tightened and that the equipment is in good condition.

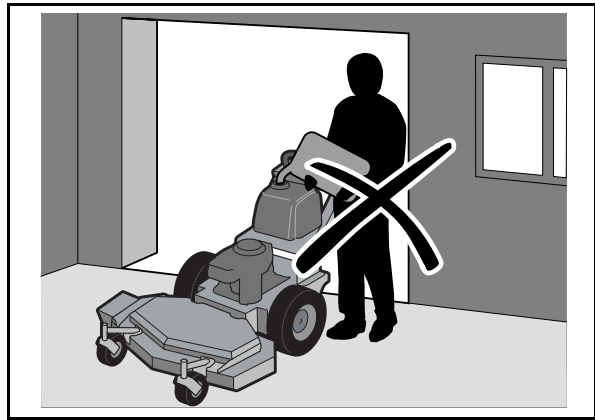

8011-637

Never fill the fuel tank indoors



WARNING!

The engine and the exhaust system components become very warm during operation. Risk for burns if touched.

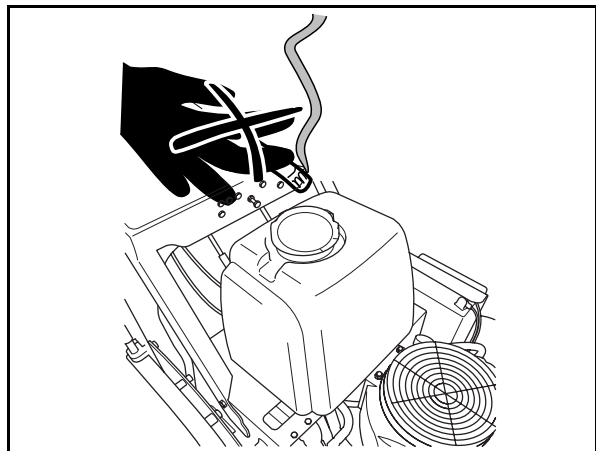

8011-777

Do not smoke when using or maintaining the machine.

SAFETY INSTRUCTIONS

- Do not modify safety equipment. Check regularly to be sure it works properly. The machine must not be driven with defective or unmounted protective plates, protective cowlings, safety switches, or other protective devices.
- Do not change the settings of governors and avoid running the engine with overly high engine speeds. If you run the engine too fast, you risk damaging the machine components.
- Never use the machine indoors or in spaces lacking proper ventilation. The exhaust fumes contain carbon monoxide, an odorless, poisonous, and lethal gas.
- Stop and inspect the equipment if you run over or into anything. If necessary, make repairs before starting.
- Never make adjustments with the engine running.
- The machine is tested and approved only with the equipment originally provided or recommended by the manufacturer.
- The blades are sharp and can cause cuts and gashes. Wrap the blades or use protective gloves when handling them.
- Check the parking brake's functionality regularly. Adjust and service as necessary.
- When mowing in familiar areas use the mulch deck.
- Reduce the risk of fire by removing grass, leaves, and other debris that may have accumulated on the machine. Allow the machine to cool before putting it in storage.
- Have your mower inspected and serviced each year by an authorized Husqvarna dealer.
- Use only authentic Husqvarna replacement parts to insure that the safety and quality of your mower is maintained.
- Safety decals should be replaced if they are missing or illegible. Decals can be purchased from your Husqvarna dealer.



8011-638

Never drive the machine in an enclosed space



8011-639

Clean the machine regularly

SAFETY INSTRUCTIONS

Transport

- The machine is heavy and can cause serious crushing injuries. Be extra cautious when it is loaded on or unloaded from a vehicle or trailer.
- Use an approved trailer to transport the machine. Activate the parking brake, turn off the fuel supply, and fasten the machine with approved fastening devices, such as bands, chains, or ropes, when transporting.
- Check and abide by local traffic regulations before transporting or driving the machine on any road.
- Do not tow this machine, it may cause damage to the drive system.
- Do not tow any trailers, etc. with this mower. They may jackknife or overturn causing damage to the mower and possibly serious injury to the operator.

IMPORTANT INFORMATION

The parking brake is not sufficient to lock the machine in place during transport. Ensure that the machine is well fastened to the transport vehicle. Reverse the machine onto the transport vehicle to avoid tipping it over.

Customer responsibilities

- Read and observe the safety rules.
- Follow a regular schedule in maintaining, caring for and using your mower.
- Follow the instructions under "Maintenance" and "Storage" sections of this owner's manual.



WARNING!

This mower is equipped with an internal combustion engine and should not be used on or near any unimproved forest-covered, bush-covered or grass-covered land unless the engine's exhaust system is equipped with a spark arrester meeting applicable local or state laws (if any). If a spark arrester is used, it should be maintained in effective working order by the operator.

A spark arrester for the muffler is available through your authorized Husqvarna dealer.

CONTROLS

Controls

This operator's manual describes the Husqvarna Walk-Behind Mowers WG3213P, WG3613P and WG4815P. The machines are fitted with a Kawasaki or Kohler four-stroke V-Twin engine, for data see "Technical data" on page 60.

Transmission from the engine is made via two V-belts, one for each wheel. Using the left and right motion controls, the speed of the rear wheels is regulated.

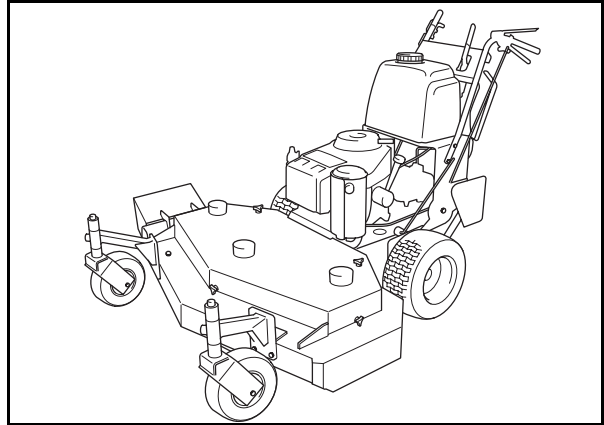

8011-708

Walk behind mower

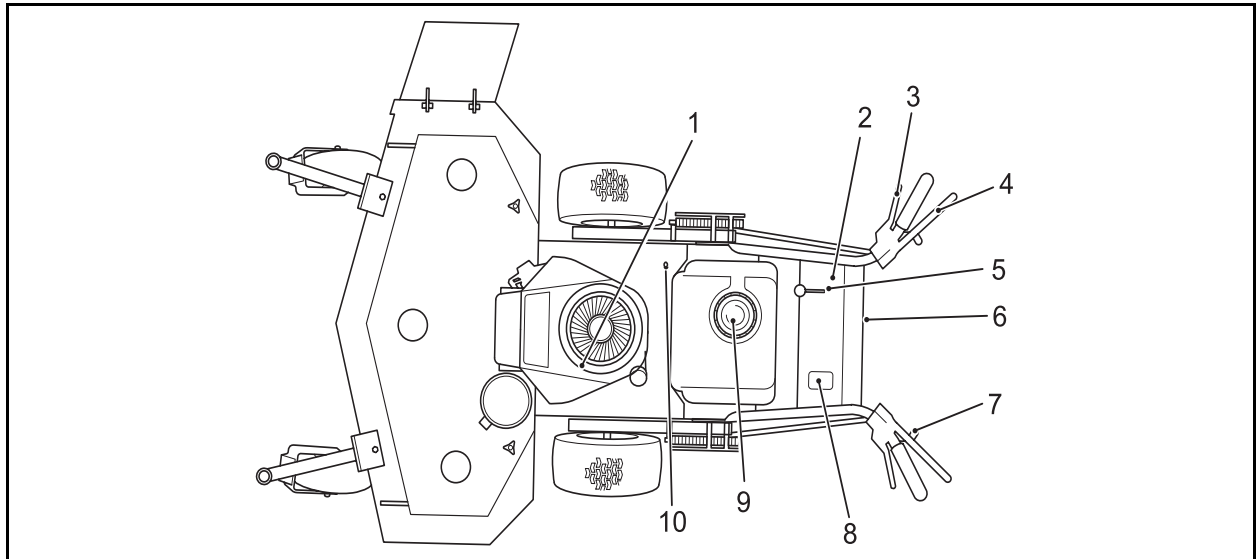

8011-680

Locations of the controls

Control Locations

	Page		Page
1. Recoil starter grip	15	6. Gear shift lever	17
2. Ignition switch	15	7. Thumb latch	18
3. Motion control lever	16	8. Blade engagement lever	18
4. Operator presence lever	16	9. Fuel cap	19
5. Choke and throttle control	17	10. Fuel shut-off valve	20

CONTROLS

1. Recoil Starter Grip

IMPORTANT INFORMATION

Do not let recoil cord snap back by itself. This may damage the cord or the recoil starter assembly.

Pull the recoil starter grip slowly until you feel compression, then pull it briskly.

Normally this engine will not backfire. If you get backfires, contact your Husqvarna dealer for service.

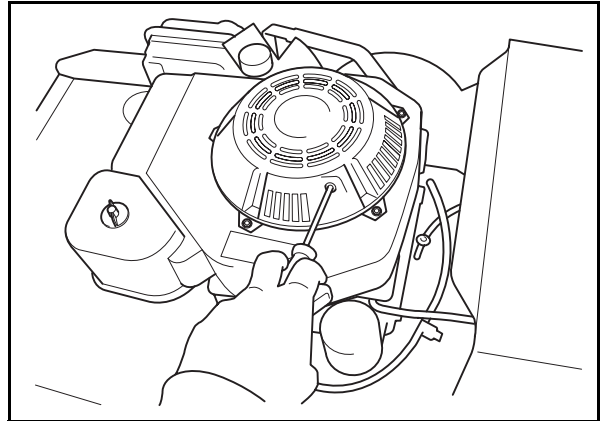

8011-498

Recoil starter grip

2. Ignition Switch

The ignition key switch is placed on the control panel.

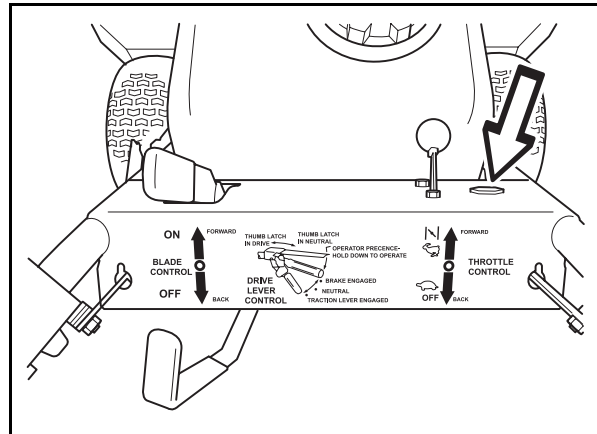

8011-693

Ignition key

CONTROLS

3. Motion control levers

The machine's speed and direction are continuously variable using the two motion control levers.

When both controls are in the neutral position, the machine stands still. The controls can be locked in neutral position by the thumb latches.

By releasing both controls an equal amount, the machine moves in a straight line forward.

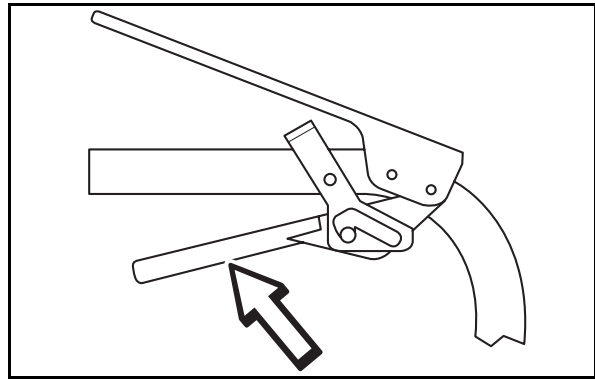

8011-660

Motion control lever

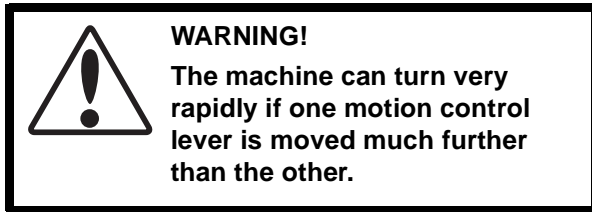

In order, for example, to turn right while moving forward, move the right control towards the handle (neutral position). The rotation of the right wheel is reduced and the machine turns to the right.

With the opposite wheel still under power a turn is accomplished. If the motion control lever is squeezed even tighter the brake will be applied to that wheel and a tighter more abrupt turn is accomplished.

4. Operator Presence Lever

Located on the handle. As an additional safety feature, these mowers are equipped with an Operators Presence System. This is an electrical interlock safety system which is activated by depressing either one or both of the Operator Presence Levers towards the handle grips.

Releasing both Operators Presence Levers while mowing or transporting will break the electrical circuit and cause the engine and mower to stop. The mower will not stop immediately after releasing the operate presence levers, some travel does occur.

One or both levers must be pressed against the handle for the engine to remain running, when the blades are engaged or thumb latches are not locked in the motion control levers.

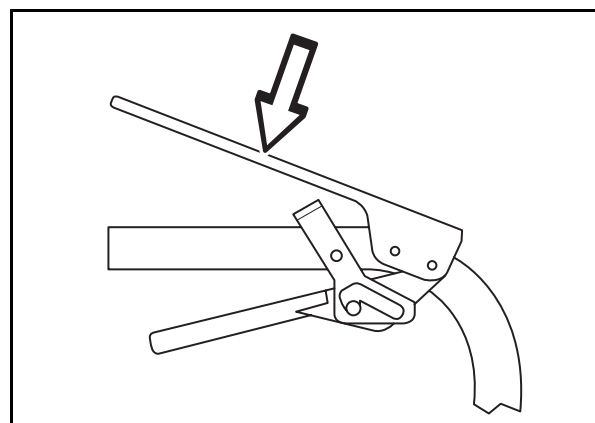

8011-658

Operator presence lever

CONTROLS

5. Choke and Throttle Control

Choke Control

The choke control is combined with the throttle control. To engage the choke, the throttle control is moved past the max rpm setting to its choke position.

Do not use the choke when starting a warm engine.

Throttle Control

The throttle control regulates the engine speed and thereby the rate of rotation of the blades, assuming the control for engaging the mower deck is pulled forward, see Engaging the Mower Deck.

In order to increase or decrease the engine speed, the control is moved downward or upward respectively.

Avoid idling the engine for longer periods, as there is a risk of the spark plugs fouling.

USE FULL THROTTLE WHEN MOWING, for best mower performance.

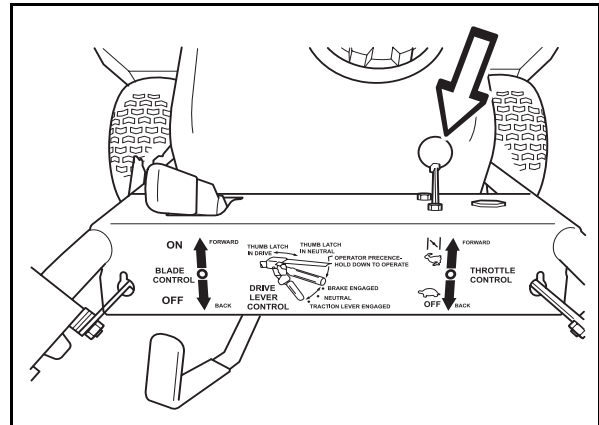

Choke and throttle control

6. Gear Shift Lever

Gear shift lever has five forward gear speeds, there is also a neutral and reverse gear.

Grip motion control levers before shifting gears.

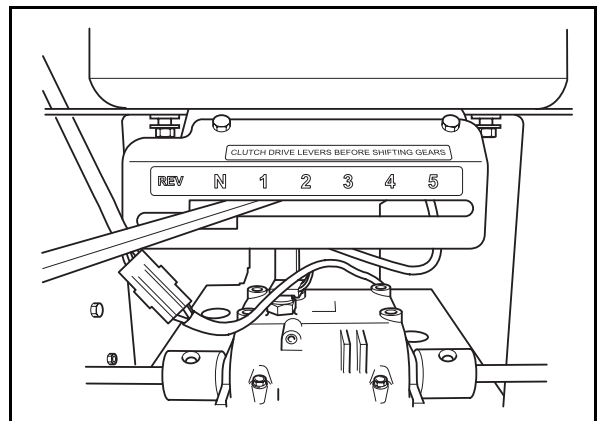

Gear shift lever in neutral position

CONTROLS

7. Thumb Latch

The thumb latches are used to lock the motion control levers in their neutral position e.g. when starting the engine.

Lock the motion control levers by pulling the thumb latches backward.

Unlock the motion control levers by pushing the thumb latches forward.

Parking Brake

Parking brake is applied when both thumb latches have locked the motion control levers in neutral position.

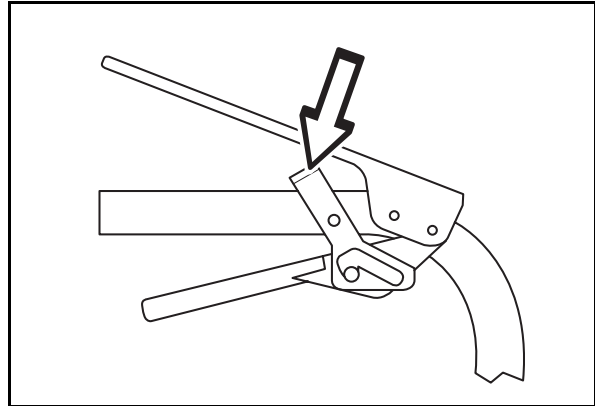

8011-659

Thumb latch, locked position

8. Blade Engagement Lever

The blade engagement lever is on the left side of the control panel.

In order to engage the blades, push the lever forward. The blades are disengaged when the lever is pulled backward.

The blade engagement lever needs to be adjusted so the lever does not come in contact with control panel when the lever is in the off position.

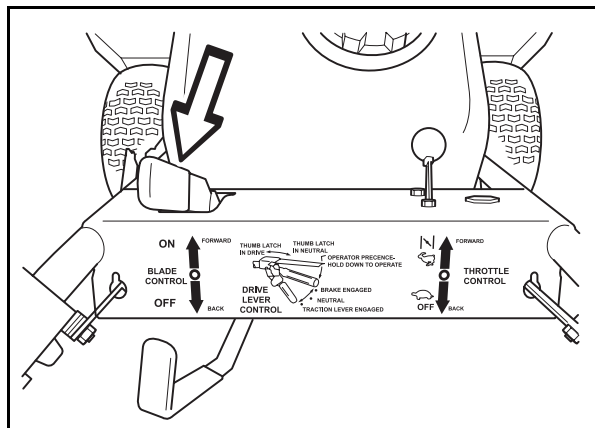

8011-694

Engaging the mower deck

CONTROLS

9. Refueling

The machine has one fuel tank. The tank volume is 5.3 Gallons / 20 liters.

The engine should be run on a minimum of 87-octane unleaded gasoline (no oil mix). See "Technical data" on page 60 concerning methanol and ethanol fuels.



WARNING!
Gasoline is highly flammable. Observe caution and fill the tank outdoors (see the safety rules).

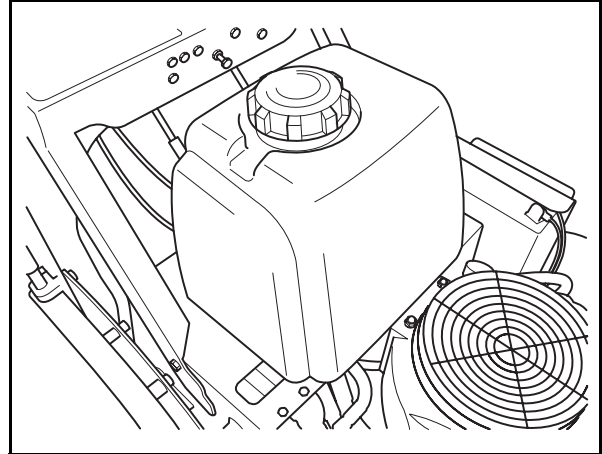

8011-418

Fuel tank



WARNING!
Fill to bottom of filler neck. Do not overfill. Wipe off any spilled oil or fuel. Do not store, spill or use gasoline near an open flame.

IMPORTANT INFORMATION

Experience indicates that alcohol blended fuels (called gasohol or using ethanol or methanol) can attract moisture which leads to separation and formation of acids during storage. Acidic gas can damage the fuel system of an engine while in storage. To avoid engine problems, the fuel system should be emptied before storage of 30 days or longer. Drain the gas tank, start the engine and let it the run until the fuel lines and carburetor are empty. Use fresh fuel the next season. See **Storage Instructions** for additional information. **Never use engine or carburetor cleaners in the fuel tank or permanent damage may occur.**

When operating in temperatures below 32° F. (0° C.), use fresh, clean winter grade gasoline to help insure good cold weather starting.

CONTROLS

10. Fuel Shut-off Valve

The fuel shut-off valve is placed on the fuel line below the fuel tank. The valve has two positions; ON and OFF. The figure shows the valve in the closed OFF position.

IMPORTANT INFORMATION

Close fuel valve at the end of each mowing job.

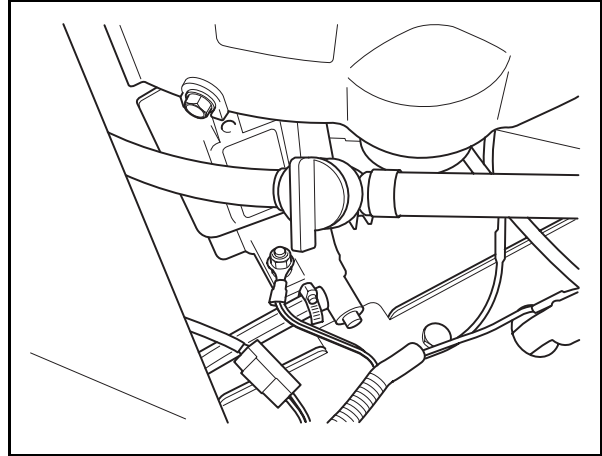

8011-437

Fuel shut-off valve, closed

Accessories

For mulching, there is a BioClip attachment available. This is mounted underneath the mower deck and consists of control plates and BioClip blades.

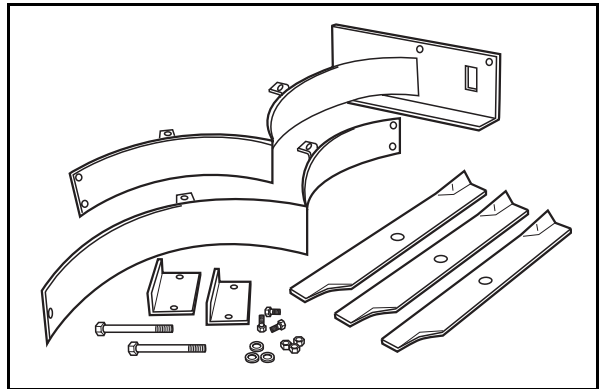

8011-566

BioClip attachment

OPERATION

Operation

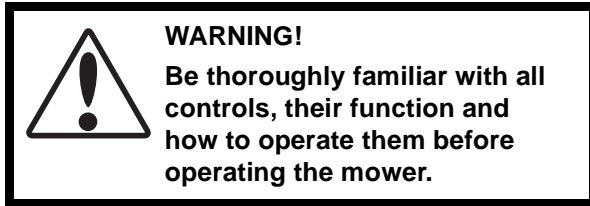

Before Starting

- Read the sections “Safety Instructions” on page 7, and “Controls” on page 14, before starting the machine.
- Perform the daily maintenance before starting (see “Maintenance Schedule” on page 35).
- Check that there is sufficient fuel in the fuel tank.

The following conditions must be fulfilled before the engine can be started:

- The control for engaging the blades must be in disengaged position.
- The thumb latches for the motion control levers must be in the locked position.

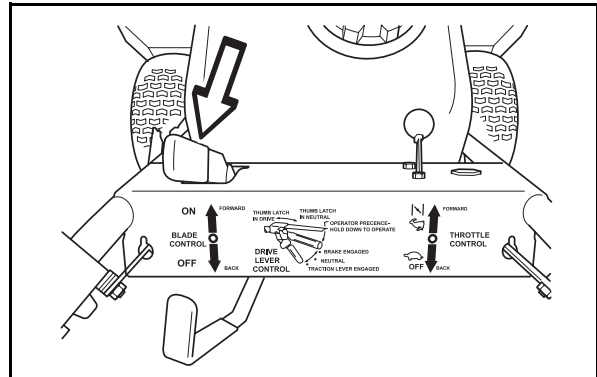
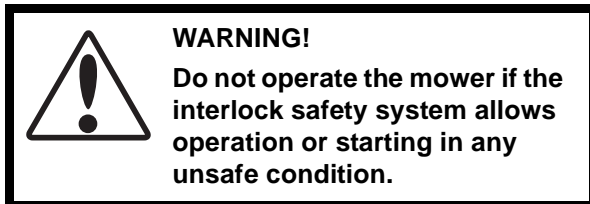

8011-694

Disengaged blades

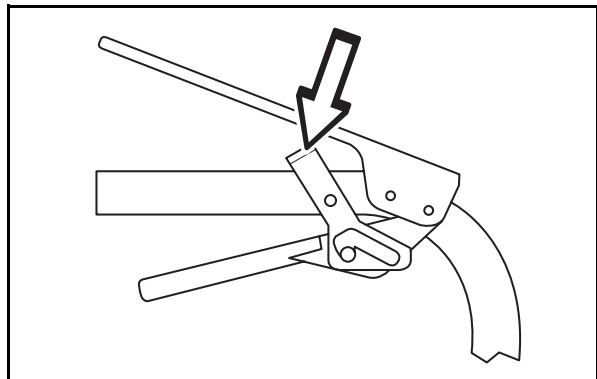

8011-699

Thumb latch in lock position

OPERATION

Starting the Engine



WARNING!
Never run the engine indoors,
in enclosed or poorly
ventilated spaces. Engine
exhaust fumes contain
poisonous carbon monoxide.

1. Move blade engagement lever to the OFF position, so the interlock will allow engine to start.

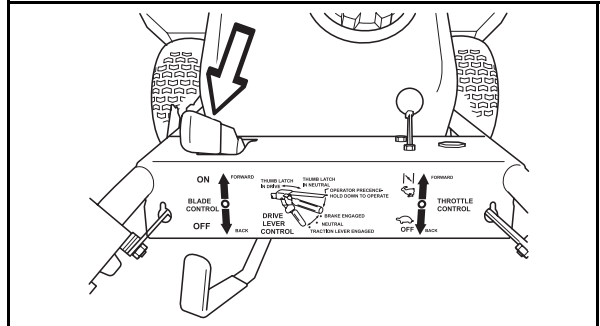

8011-694

Blade engagement lever OFF

2. Check gear shifter to be sure it is in the neutral position.

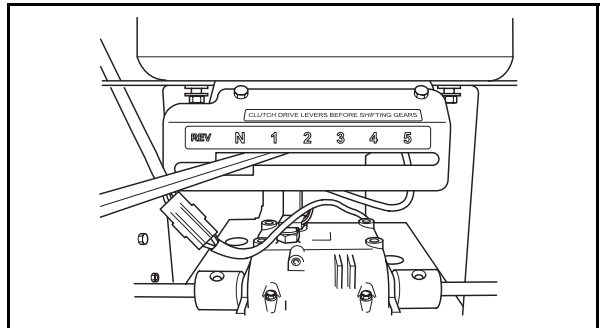

8011-482

Gear shifter in neutral position

3. While on level terrain, squeeze both motion control levers and set thumb latches to lock them into the neutral position.

This will ensure that mower's clutch is engaged and the brake set.

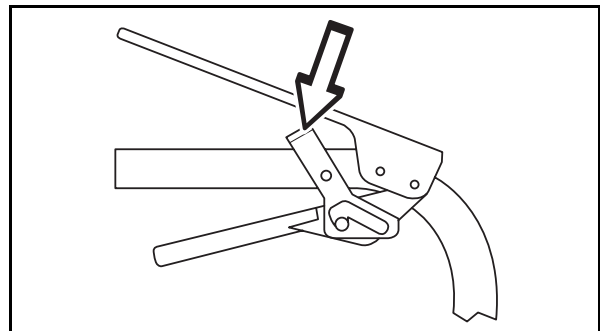

8011-659

Thumb latches in locked position

OPERATION

4. Open fuel shut-off valve.

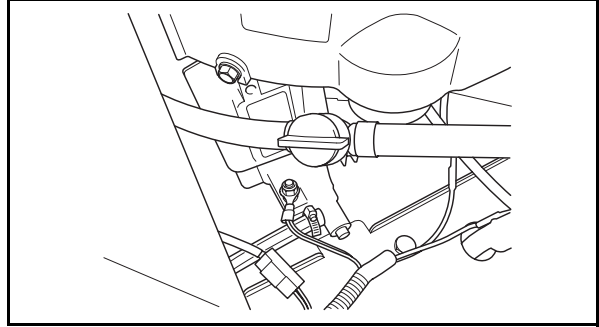

8011-438

Fuel shut-off valve, Open

5. Turn ignition key to ON position.

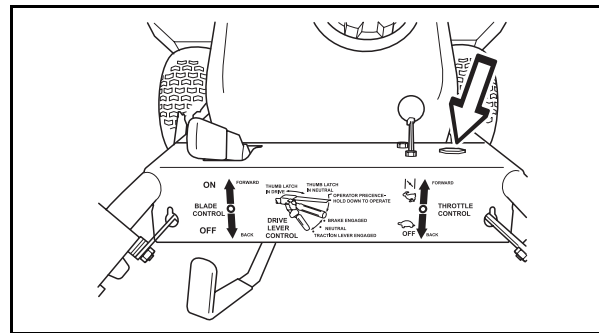

8011-693

Ignition key

6. Set throttle control and engage the choke (if needed).
Do not use choke when the engine is warm.

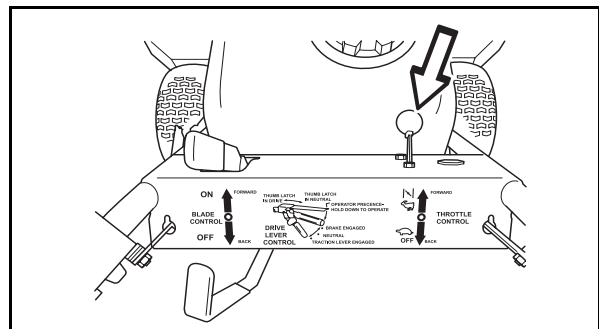

8011-709

Choke and Throttle control

OPERATION

IMPORTANT INFORMATION

Do not let recoil cord snap back by itself. This may damage the cord or the recoil starter assembly.

7. Pull the recoil starter grip slowly until you feel compression, then pull it briskly.
If the engine won't start in three pulls, open the choke and try again.
8. Warm engine momentarily, then disengage the choke until engine runs smoothly, approximately 1/2 throttle.

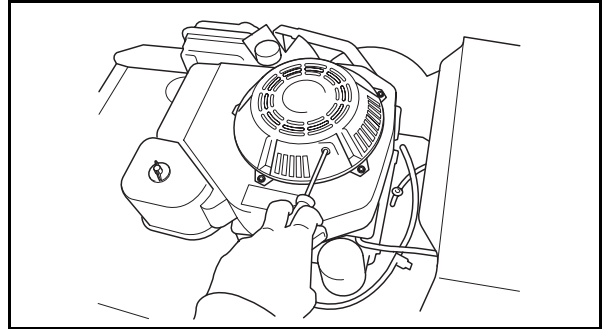

8011-498

Pull the starter grip



WARNING!

Be sure all persons are clear of area before engaging the blades.

IMPORTANT INFORMATION

To prolong spindle bearing, clutch and belt life engage and disengage blades at approximately 1/2 throttle.

9. Depress one operator presence lever. Engage the blades and set the desired rpm. The best cutting and bagging is obtained with engine at **top rpm**.

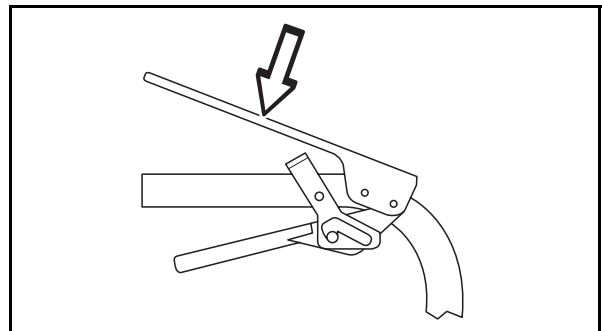

8011-658

Presence lever

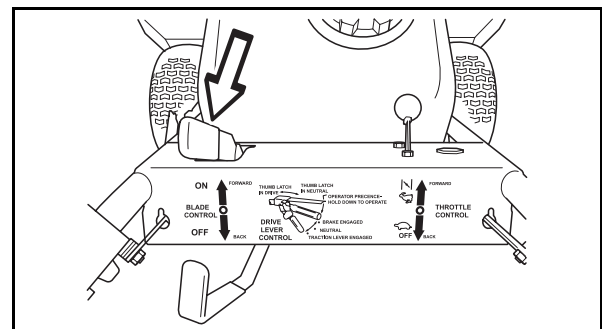

8011-694

Blade engaged

OPERATION

Gearbox

The gear drive machines have a 5-speed gearbox. The gear shift lever is placed below the control panel.

Only shift gear when the machine is standing still and on level ground.

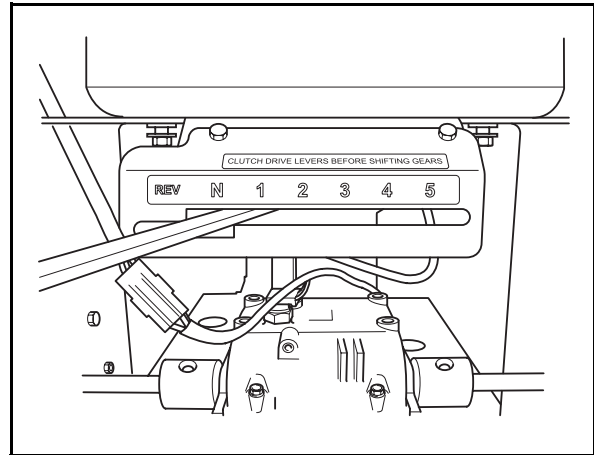

8011-482

Gear shift lever

Running

IMPORTANT INFORMATION

At least one of the Operator Presence Levers must be held in, otherwise the engine will stop.

1. Depress one Operator Presence Lever and shift transmission to the desired gear.
2. Unlock the motion control levers by pushing the thumb latches forward. Slowly release both motion control levers at the same time to begin forward motion.
3. The steering system of this mower uses individual right and left motion control levers on the handle bars. Squeezing the motion control lever will reduce tension on the wheel drive belt eliminating power to that wheel. With the opposite wheel still under power a turn is accomplished.
4. If the motion control lever is squeezed even tighter the brake will be applied to that wheel and a tighter more abrupt turn is accomplished. Turn left by squeezing the left hand motion control lever or turn right by squeezing the right hand motion control lever. If you squeeze both levers the mower will stop.

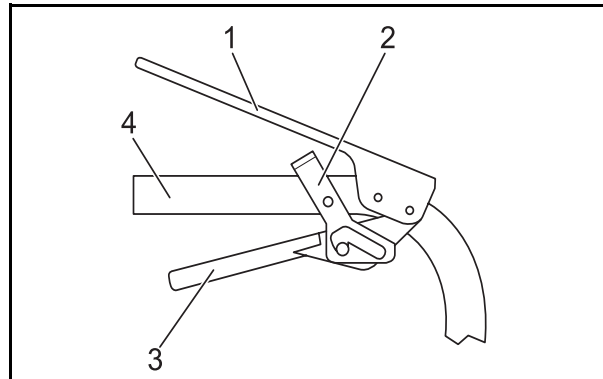

8011-402

1. Operator Presence Lever
2. Thumb Latch
3. Motion Control Lever
4. Handle

Pistol grip with thumb latch in neutral position

OPERATION

Reversing

Depress one operator presence lever and shift transmission to the reverse gear. Grip both motion control levers before shifting gear.

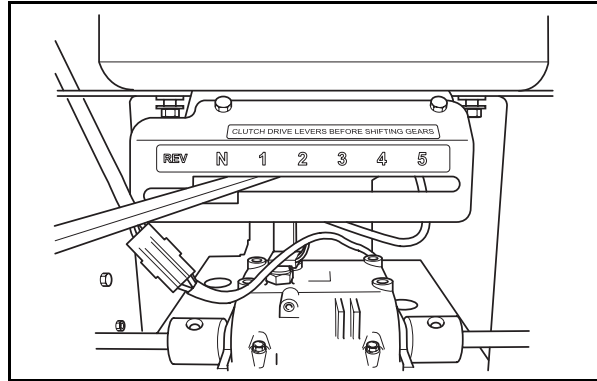

8011-402

Gear shifting to reverse

To operate on hills

To operate on slopes is a dangerous mowing job. Read the Safety Instructions section "Driving on Slopes" on page 9.



WARNING!
Do not drive up or down hills with slopes greater than 10 degrees. And do not drive across any slopes.

- The slowest speed possible should be used before starting up or down hills.
- Avoid stopping or changing speed on hills.
- Make all turns slowly.

OPERATION

Mowing Tips

- Observe and mark rocks and other fixed objects in order to avoid collisions.
- The cutting deck should be properly leveled for best mowing performance. The blades should be parallel to the ground or slightly tipped down in the front.
- Only use sharp blades.
- Check tire pressure. Different pressure can cause uneven mowing result.
- The left hand side of the deck should be used for trimming.
- Drive so that clippings are discharged onto the area that has been cut. Have the cut area to the right of the mower. This will result in more even distribution of clippings and a more uniform cut. To avoid clippings spraying on roads etc, mow the first two patterns in opposite direction.
- Begin with a high cutting height and reduce it until the desired mowing result is attained.

The average lawn should be cut to 2 1/2" (64 mm) during the cool season and to over 3" (76 mm) during the hot months. For healthier and better looking lawns, mow often after moderate growth.

For best cutting performance, grass over 6" (15 cm) in height should be mowed twice. Make the first cut relatively high; the second to the desired height.

- The mowing result will be best with a high engine speed (the blades rotate rapidly) and low speed (the machine moves slowly). If the grass is not too long and dense, the driving speed can be increased without noticeably depreciating the mowing result.
- The finest lawns are obtained by mowing often. The mowing becomes more even and the grass clippings more evenly distributed over the mown area. The total time taken is not increased as a higher driving speed can be used without poorer mowing results.

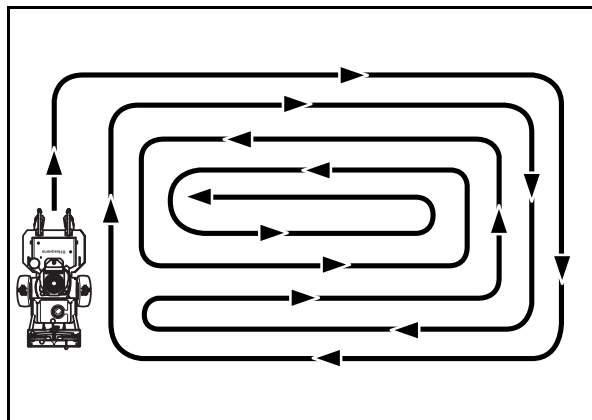
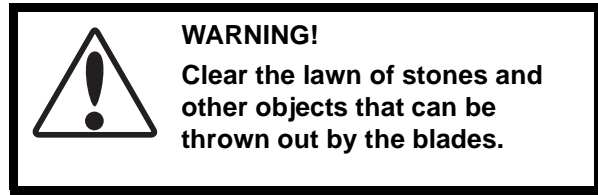

Mowing patterns

8011-409

OPERATION

- Avoid mowing wet lawns. The mowing result is poorer because the wheels sink into the soft lawn, clumps build, and the grass clippings will fasten under the cowling.
- Hose the mower deck with water after each use. Hose especially underneath. Do not spray high pressure spray directly on top of spindles.
- Avoid getting engine too wet.



WARNING!

Never drive the machine on terrain that slopes more than 10°. Mow slopes up and down, never side-to-side. Avoid sudden directional changes.



8011-514

Clean mower deck after each use

OPERATION

Stopping

Emergency stop

Release both hands from the operator presence lever handles.

When both operator presence levers return to their outer position, the engine will quit and the mower will stop.

or

Pull both motion control levers firmly against handle grips and hold them securely in place. Use thumb latches to lock both motion control levers in neutral positions. Then stop engine by pulling throttle control back and shut off the key switch.

Normal operating stop

1. Pull both motion control levers firmly toward the handle grips to stop forward motion.
2. Use thumbs to lift thumb latches into the neutral slots.
3. Move the throttle control to the slow position.
4. Move blade engagement control to the off position.
5. Move shift lever to the neutral position.
6. Stop engine, refer to "Stopping the Engine" on page 30.

IMPORTANT INFORMATION

Close fuel valve at the end of each mowing job.

Braking

Squeeze both motion control levers towards the handle grips. If desired secure them using the thumb latches for parking brake.

OPERATION

Stopping the Engine

Allow the engine to idle a minute in order to attain normal operating temperature before stopping it, if it has been worked hard. Avoid idling the engine for longer periods, as there is a risk of the spark plugs fouling.

1. When the machine is standing still, activate the parking brake by moving the thumb latches to the park brake position.
2. Disengage the blades by the blade engagement lever.

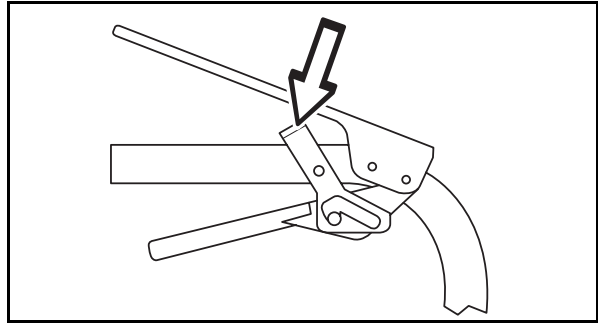

8011-659

Parking brake

3. Move the throttle to the idle position (tortoise symbol). Turn the ignition key to the stop position.
4. Remove the ignition key.

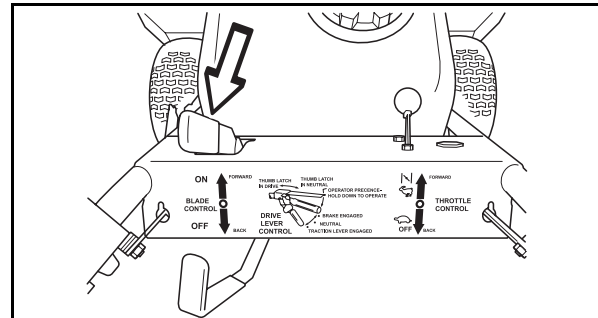

8011-694

Disengage the blades

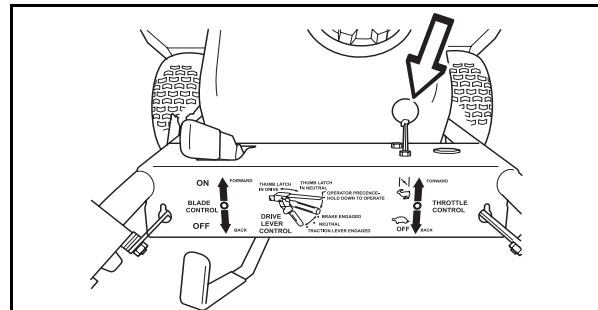

8011-709

Throttle

5. Shut OFF the fuel valve.

IMPORTANT INFORMATION

Close fuel valve at the end of each mowing job.

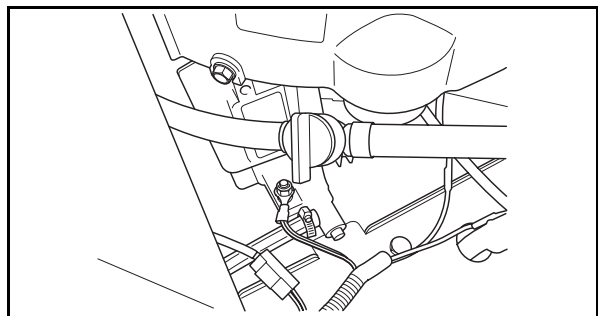

8011-437

Fuel valve, closed

OPERATION

Adjustment of cutting height

The cutting height can be adjusted by three methods:

- Moving spacers between the upper side and the lower side of the caster swivel according to "Cutting height table". For instruction, see below.
- Moving spacers between the upper side and the lower side of the blades according to "Cutting height table". For removing and installation of blades, refer to "Blade replacement" on page 46.
- Rear axle height adjustment according to the following instruction.
 1. To adjust rear axle, stop engine and place motion control levers in the neutral lock position, remove spark plug wires.
 2. Remove lower belt shield from underside of rear deck for better access to axle adjustment bolts.
 3. Loosen axle pivot bolts and axle adjustment bolts.
 4. Place a jack under center of rear deck raise the jack slightly so axle adjustment bolts may be removed.
 5. With the jack raise or lower the rear deck to the desired position using the chart to ensure proper height.
 6. Reinstall the axle adjustment bolts and tighten. A tapered punch may be used to help align the holes.
 7. Using the "Cutting height table", find the correct number of spacers to be placed under the caster swivel
 8. Remove the lynch pin and washer from the top of caster and reposition spacers to the desired cutting height from the table. See illustration.

IMPORTANT INFORMATION

It may be necessary to readjust drive and brake linkages.

IMPORTANT INFORMATION

To achieve the best quality cut, the blades should be level with the ground or slightly tipped forward.

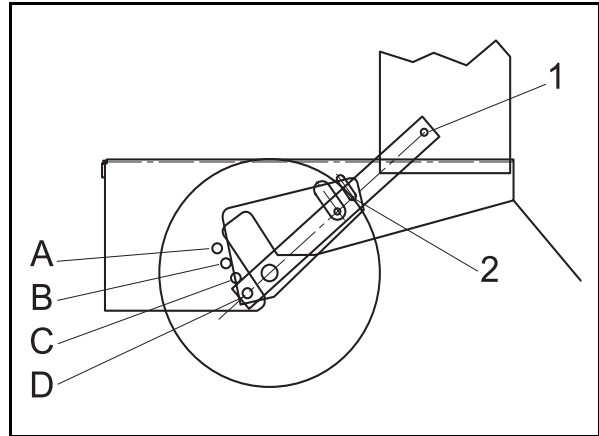

8011-408

1. Axle pivot bolt
 2. Securing bolts (Loosen each side)
 - A-D. Axle adjustment bolts
- Rear axle height adjustment*

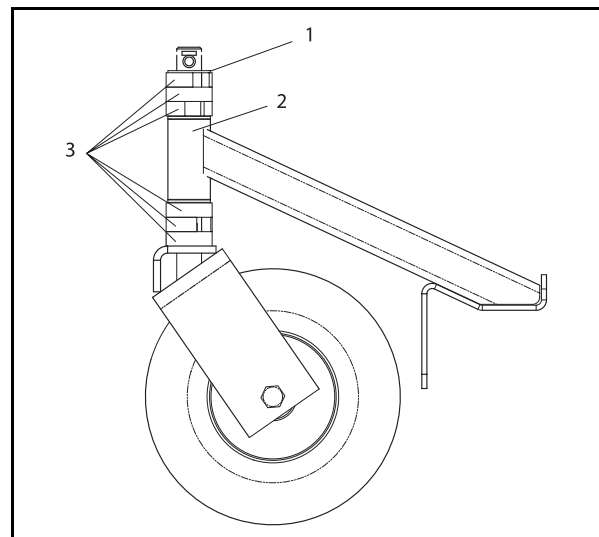

8011-405

1. Machinery bushing
 2. Caster swivel
 3. 1/2" "C" Spacers
- Caster height adjustment*

OPERATION

Cutting height table

Axle position	Spacers below caster arm	Blade spacers under cutter housing	Cutting height
A	0	4	1 1/2" (38 mm)
		3	1 3/4" (44 mm)
		2	2" (51 mm)
		1	2 1/4" (57 mm)
		0	2 1/2" (64 mm)
	1	4	1 3/4" (44 mm)
		3	2" (51 mm)
		2	2 1/4" (57 mm)
		1	2 1/2" (64 mm)
		0	2 3/4" (70 mm)
B	2	4	2 1/2" (64 mm)
		3	2 3/4" (70 mm)
		2	3" (76 mm)
		1	3 1/4" (83 mm)
		0	3 1/2" (89 mm)
	3	4	3" (76 mm)
		3	3 1/4" (83 mm)
		2	3 1/2" (89 mm)
		1	3 3/4" (95 mm)
		0	4" (102 mm)

OPERATION

Axle position	Spacers below caster arm	Blade spacers under cutter housing	Cutting height
C	3	4	3 1/4" (83 mm)
		3	3 1/2" (89 mm)
		2	3 3/4" (95 mm)
		1	4" (102 mm)
		0	4 1/4" (108 mm)
	4	4	3 1/2" (89 mm)
		3	3 3/4" (95 mm)
		2	4" (102 mm)
		1	4 1/4" (108 mm)
		0	4 1/2" (114 mm)
D	4	4	3 3/4" (95 mm)
		3	4" (102 mm)
		2	4 1/4" (108 mm)
		1	4 1/2" (114 mm)
		0	4 3/4" (121 mm)
	5	4	4" (102 mm)
		3	4 1/4" (108 mm)
		2	4 1/2" (114 mm)
		1	4 3/4" (121 mm)
		0	5" (127 mm)

OPERATION

Moving Machine by Hand

In order for the machine to be moved with the engine turned off, make sure the gear shift lever is in neutral position.

Release the parking brake.

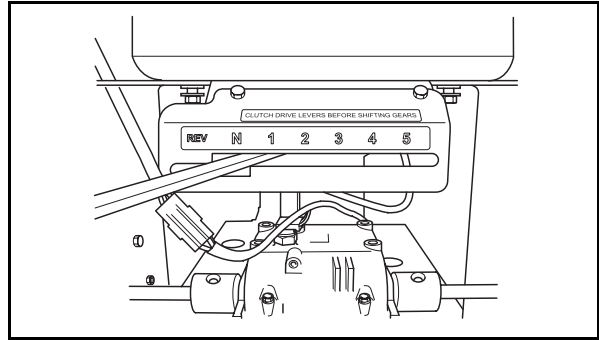

8011-482

Gear shift lever in neutral position

MAINTENANCE

Maintenance

Maintenance Schedule

The following is a list of maintenance procedures that must be performed on the machine. For those points not described in this manual, visit an authorized service workshop. An annual service carried out by an authorized service workshop is recommended in order to maintain your machine in the best possible condition and to ensure safe operation.

Read Safety Instructions section "Maintenance" on page 10.

¹⁾ First change after 8 hours. When operating with a heavy load or at high ambient temperatures, replace every 50 hours. ²⁾ In dusty conditions, cleaning and replacement are required more often. ³⁾ For daily use, the machine should be lubricated twice weekly. ⁴⁾ Performed by authorized service workshop.

● = Described in this manual

○ = Not described in this manual

Maintenance	Page	Daily maintenance		Weekly maintenance	At least once each year	Maintenance interval in hours			
		Before	After			25	50	100	300
Check for fuel and oil leakages	-	○							
Check the parking brake	43	●							
Check the engine's oil level (every refueling)	50	●				●			
Front and rear tires: Damage, pressure	42	●							
Check the fuel pump's air filter (Kawasaki)	42					●			
Check the safety system	38	●							
Check/clean the engine's cooling air intake	38		●			●			
Check the cutting deck	44					●			
Check underside of rear deck	44		●						
Check hardware (screws, nuts, etc.)	45		●						
Start the engine and blades, listen for unusual sounds	-		○						
Clean under the mower deck	45		●						
Inspect/Replace blades ²⁾	46	●							
Check the condition of belts, belt pulleys, etc.	43				●				
Check for damage	-		○						
Thoroughly clean around the engine	-		○						
Clean around belts, belt pulleys, etc.	-		○						

MAINTENANCE

Maintenance	Page	Daily maintenance		Weekly maintenance	At least once each year	Maintenance interval in hours			
		Before	After			25	50	100	300
Check/adjust the cutting height	-				○				
Linkages and adjustments	45							●	
Check throttle and choke cables	39							●	
Clean the air cleaner's pre-filter (foam)	40				●	●			
Clean the air cleaner's filter cartridge ²⁾ (paper filter)	40				●		●		
Change the engine oil ¹⁾	67				●			●	
Replace the engine oil filter (every 200 hours)	50				●			●	
Clean/Replace the spark plugs	37				●			●	
Replace the fuel filter	42				●			●	
Clean the cooling fins	-				○			○	
Check the engine valve clearance ⁴⁾	-				○				○
Replace the air cleaner's pre-filter (foam)	40				●				●
Replace the air filter (paper filter, every 200 hours) ²⁾	40				●			●	
Check the caster wheels (every 200 hours)	45							●	
Lubricate according to Lubrication Schedule	65		●	●	●	●	●	●	●
Perform the 300-hour service ⁴⁾	95				○				○
Check/adjust the parking brake	-				○		○		

¹⁾ First change after 8 hours. When operating with a heavy load or at high ambient temperatures, replace every 50 hours. ²⁾ In dusty conditions, cleaning and replacement are required more often. ³⁾ For daily use, the machine should be lubricated twice weekly. ⁴⁾ Performed by authorized service workshop.

- = Described in this manual
- = Not described in this manual



WARNING!

No adjustments or maintenance to be carried out unless:

- The engine is stopped.
- The ignition key has been removed.
- The parking brake is on.

MAINTENANCE

Ignition System

The engine is equipped with an electronic ignition system. Only the spark plugs require maintenance.

For recommended spark plugs, see Technical Data.

1. Remove the ignition cable boot and clean around the spark plug.
2. Remove the spark plugs with a spark plug socket wrench.
3. Check the spark plugs. Replace the spark plug if the electrodes are burned or if the insulation is cracked or damaged. Clean the spark plug with a steel brush if it is to be reused.
4. Measure the electrode gap with a gapping tool. The gap shall be 0.030" (0.75 mm). Adjust as necessary by bending the side electrode.
5. Reinsert the spark plugs, turning by hand to avoid damaging the threads.
6. After the spark plugs are seated, tighten it using a spark plug wrench so that the washer is compressed. Used spark plugs should be turned 1/8 of a turn from the seated position. New spark plugs should be turned 1/4 of a turn from the seated position.
7. Connect the ignition cable.

IMPORTANT INFORMATION

Fitting the wrong spark plug type can damage the engine.

Inadequately tightened spark plugs can cause overheating and damage the engine. Tightening the spark plugs too hard can damage the threads in the cylinder head.

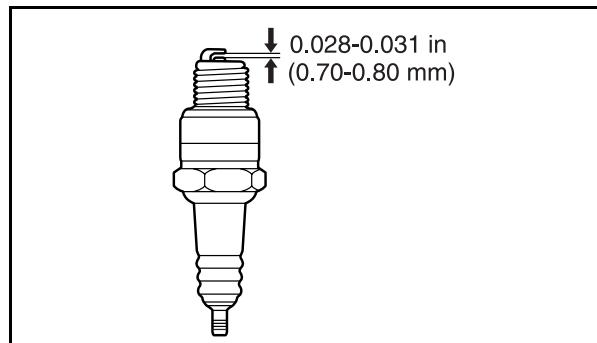

8011-054

Measure the electrode gap

MAINTENANCE

Kawasaki Engine Air Filter

If the engine seems weak or runs unevenly, the air filter may be clogged. If run with a dirty air filter, the spark plugs can become fouled and disrupt operation.

For this reason, it is important to replace the air filter regularly (see the heading Maintenance Schedule for the proper service interval).

Cleaning/replacing the air filter is carried out as follows:



WARNING!

Allow the exhaust system to cool before performing service. Risk for burns.

1. Depress the two tabs.
2. Remove the air filter cowl.
3. Remove the paper filter.
4. Remove the foam pre-filter and clean using a mild detergent.

Squeeze it dry with a clean cloth.

IMPORTANT INFORMATION

Do not use compressed air to clean the air filter.

Do not wash the paper filter.

Do not oil the paper filter.

5. Refit the air filter as follows:
Check that the paper filter is intact.
Mount the pre-filter under the paper filter.
Mount the paper filter in the air filter cowl.
6. Install the filter cowl on the air filter housing.

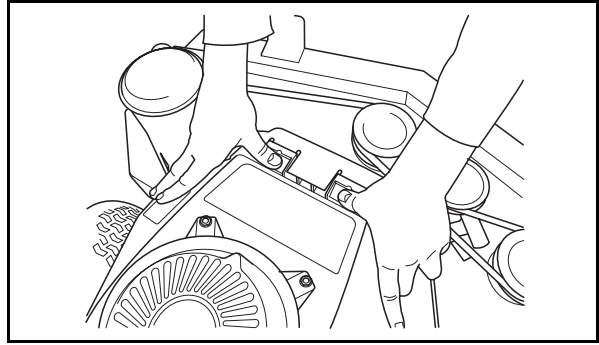

8011-486

Remove the air filter cowl

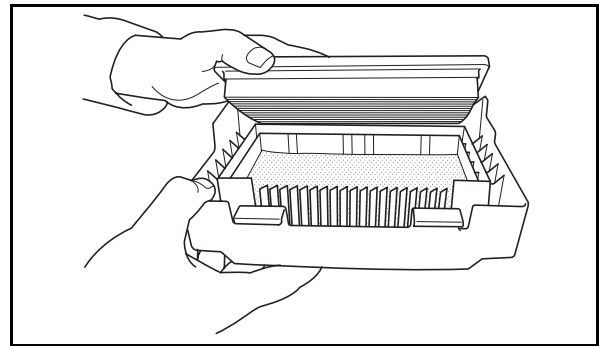

8011-487

Remove the paper filter

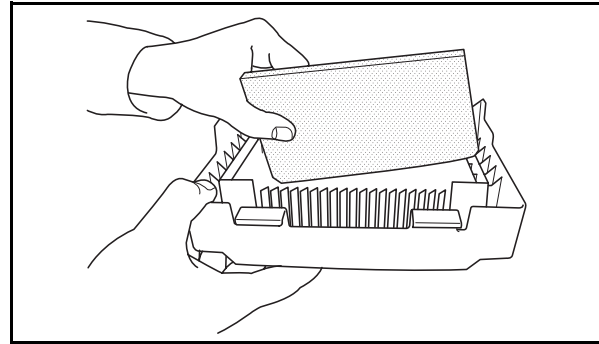

8011-488

Remove the pre-filter

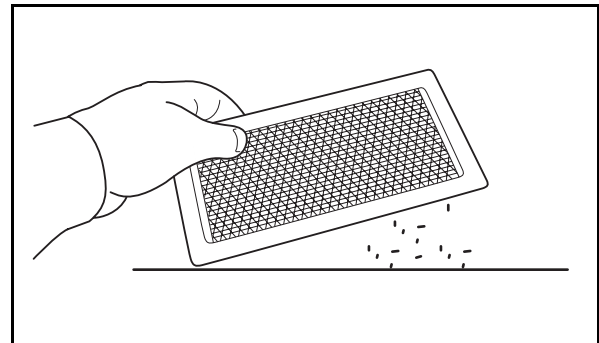

8009-450

Remove dust

MAINTENANCE

Kohler Engine Air Filter

If the engine seems to lack power or runs rough the reason may be that the air filter is clogged.

It is therefore important to service the air filter at regular intervals (see "Maintenance Schedule" on page 35 for correct service interval).

1. Fold open the engine cover.
2. Unscrew the wing nut (A) on top of the air filter and remove the cover.
3. Carefully remove the precleaner. Wash and re-oil the precleaner. Wash the precleaner in warm water with detergent. Rinse precleaner with clear warm water. Squeeze water out (do not wring to avoid tearing). Allow to dry before lightly oiling with fresh engine oil and installing it over the paper filter.
4. Replace the paper filter if it is clogged with dirt. Unscrew the wing nut (B) and remove the paper filter.

IMPORTANT INFORMATION

Never use compressed air to clean the air filters.

Paper filter should not be oiled or washed. It should be assembled dry.

5. The paper filter may be carefully tapped on a hard surface to remove dust. Do not try to wash or blow it with compressed air.
6. Insert the paper filter and check that it is correct sealed to its seat. Tighten the paper filter wing nut and install the precleaner over the paper filter.
7. Fit the air filter cover and tighten its wing nut.

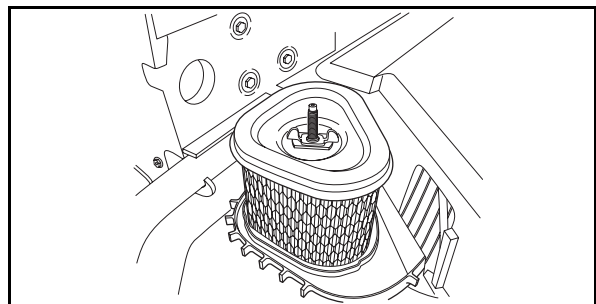
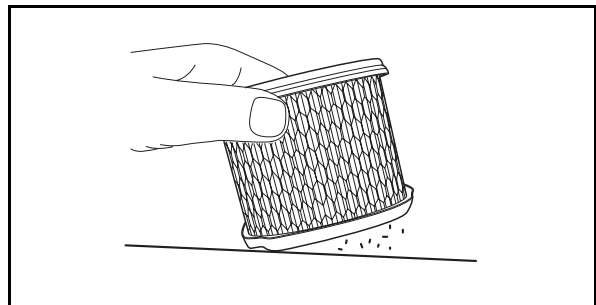
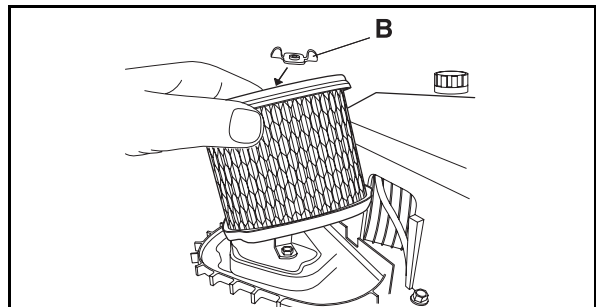
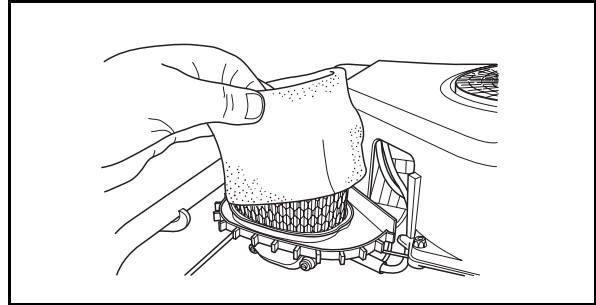
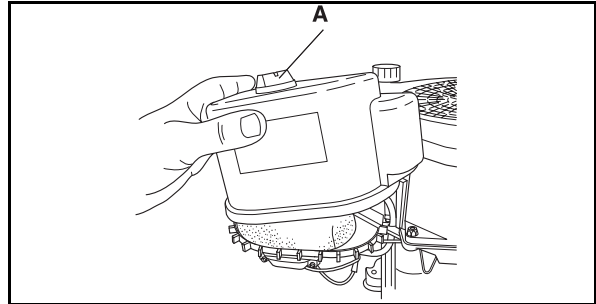

MAINTENANCE

Replacing the Fuel Filter

Replace the line-mounted fuel filter every 100 hours (once per season) or more regularly if it is clogged.

Replace the filter as follows:

1. Move the hose clamps away from the filter. Use flat-nosed pliers.
2. Pull the filter loose from the hose ends.
3. Push the new filter into the hose ends. Position the filter with the "FLOW" arrow pointing up toward the fuel pump. If necessary, a soap solution can be applied to the filter ends to ease mounting.
4. Move the hose clamps back toward the filter.

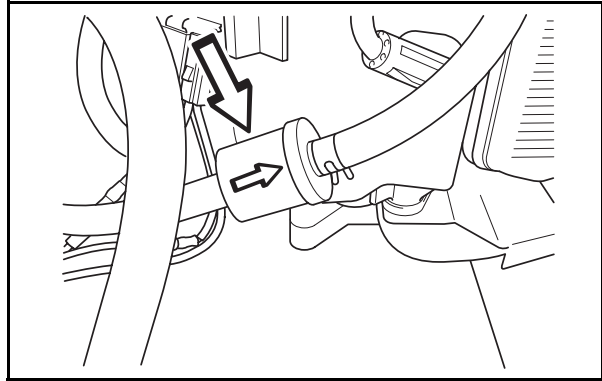

8011-425

Fuel filter

Checking the Fuel Pump's Air Filter

Kawasaki engine only.

Regularly check that the fuel pump's air filter is free from dirt.

Remove the screws and open the pump, no hoses need be removed.

The filter can be cleaned with a brush if necessary.

Replace the filter on the bracket.

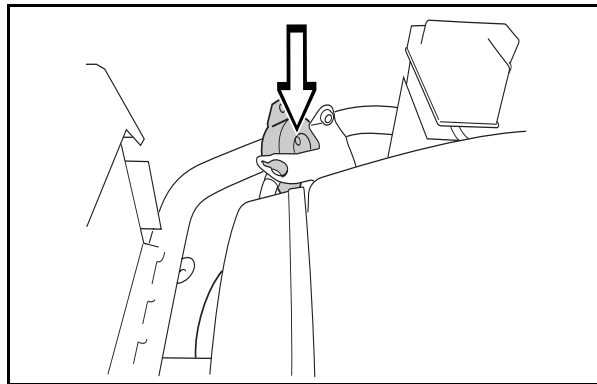

8009-147

The fuel pump's air filter

Checking Tire Pressures

All four tires shall have a pressure of 15 PSI (1 bar).

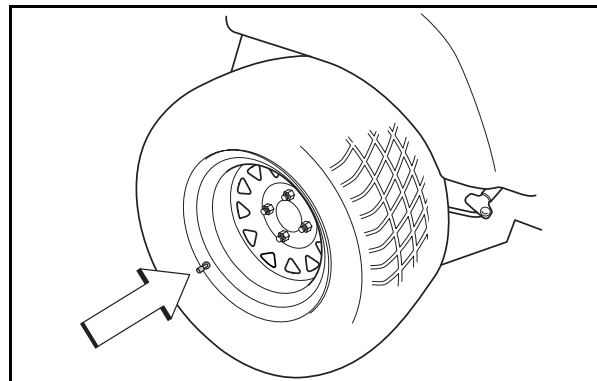

8011-564

Tire pressures

MAINTENANCE

Checking the Parking Brake

Visually check that no damage is found on the thumb latches. Perform a test drive and check that there is a sufficient braking action.

To adjust the brake, contact the service workshop if you are uncertain. Set the thumb latches in the neutral locked position. Tighten the wing nut. Check if the machine is braked, if not tighten the wing nut again.

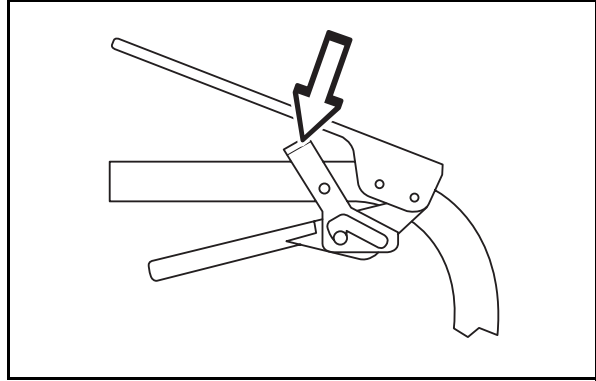

8011-659

The thumb latches in locked position

Checking the V-belts

Deck belt

Check every 100 hours of operation. Check for severe cracking and large nicks.

NOTE: The belt will show some small cracks in normal operation.

To replace belt lower the deck to its lowest position. Remove the plate and belt shields.

Use a ratchet with a 9/16" socket on the spring idler bolt to relieve the tension on the belt. Slide the belt off the pulley and remove the belt.

Reverse the procedure for installation. See the decal on the top of deck for belt routing information.

After installation is complete check the belt for twists.

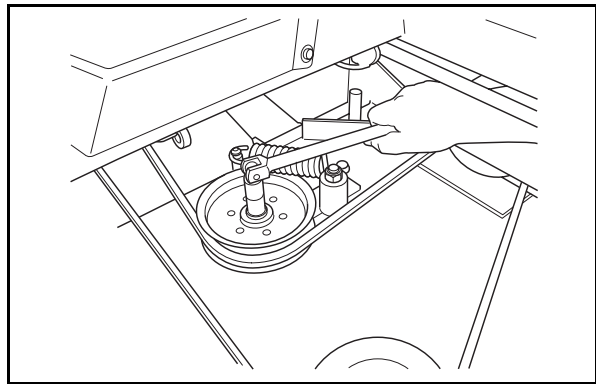

8011-698

Slackening the belt tensioner

MAINTENANCE

Checking the Blades

In order to attain the best mowing effect, it is important that the blades are well sharpened and not damaged.

Bent or cracked blades or blades with large nicks must be replaced.

Check the blade mounts.

IMPORTANT INFORMATION

The replacement or sharpening of blades should be carried out by an authorized service workshop.

Damaged blades should be replaced when hitting obstacles that result in a breakdown. Let the service workshop decide whether the blade can be repaired/ground or must be replaced.

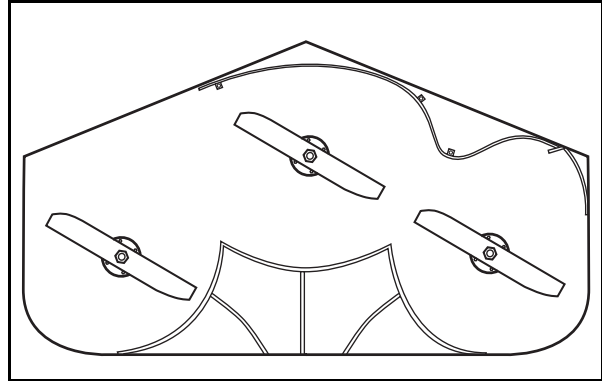

8011-604

Check the blades



WARNING!

Blades are sharp. Protect your hands with gloves and/or wrap blades with a heavy cloth when handling.

Brake rod adjustment

1. Make sure the rod is installed into the proper hole in the brake arm. The brake rod should be in the bottom hole on the brake arm.
2. To increase braking, turn the wing nut down on the rod. Do not turn the wing nut down too far as this will result in a constant braking action and will excessively wear the brake lining and cause premature failure.

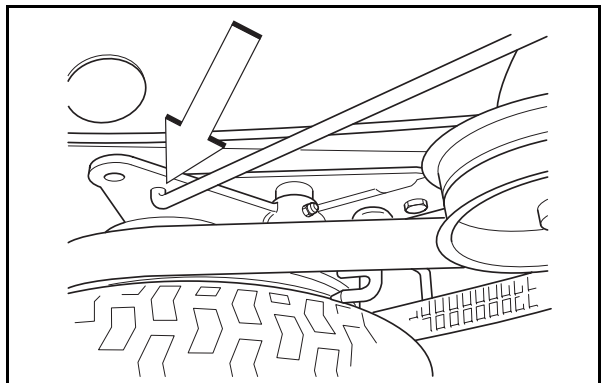

8011-774

Brake rod position

Under side of rear deck

Remove grass and debris.

MAINTENANCE

Cleaning and Washing

Regular cleaning and washing, especially under the mower deck, will increase the machine's lifespan. Make it a habit to clean the machine directly after use, before the dirt sticks. Do not spray high pressure water directly on the top of the deck.



8011-639

Cleaning

Caster Wheels

Check every 200 hours. Lift front of unit off of ground so caster wheels can rotate freely. Tighten caster bolt (34) then back off 1/2 turn. Check that wheel rotates freely. If wheel does not rotate freely back the caster bolt off in 1/4 turn increments until wheel rotates freely.

IMPORTANT INFORMATION

DO NOT add any type of tire liner or foam fill material to the tires. Excessive loads created by foam filled tires will cause premature failures.

Only use O.E.M. specified tires.

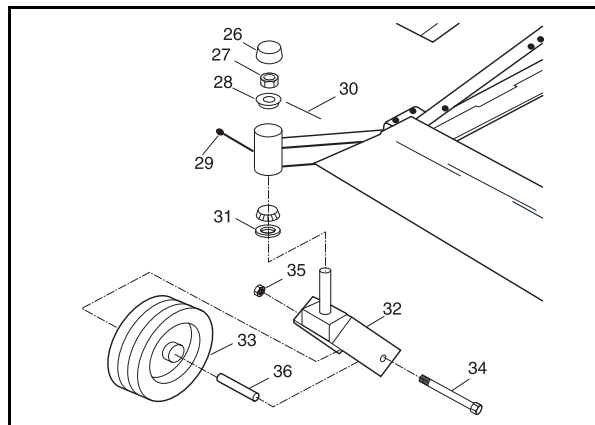

8011-619

Caster wheels

Foam filled tires or solid tires will void the warranty.

Hardware

Check daily. Inspect the entire machine for loose or missing hardware.

MAINTENANCE

Blade replacement

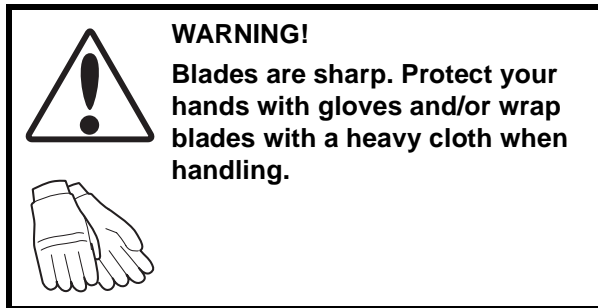

- Remove blade bolt by turning counterclockwise.

IMPORTANT INFORMATION

To ensure proper assembly, center hole in blade must align with star on cutter housing,

- Install new or re-sharpened blade with stamped "GRASS side" facing towards ground/grass (down) or "THIS SIDE UP" facing deck and cutter housing.
- Install and tighten blade bolt securely. Tightening torque 90 ft/lb (122 Nm).

IMPORTANT INFORMATION

Special blade bolt is heat treated. Replace with a Husqvarna bolt if required. Do NOT use lower grade hardware than specified.

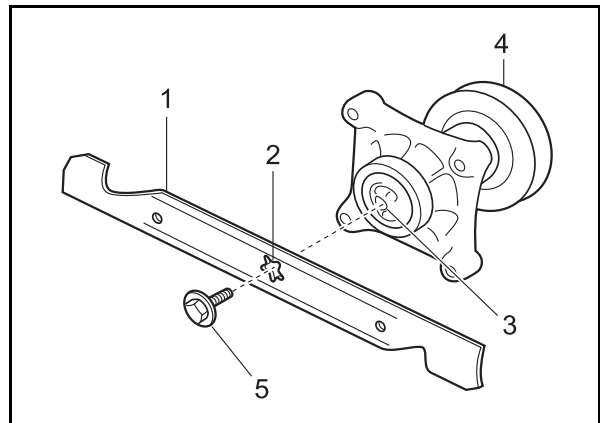

8011-671

1. Blade
2. Center hole
3. Star
4. Cutter housing
5. Blade bolt (special)

Blade attachment, principal

LUBRICATION

Lubricating the Cables

If possible, lubricate both ends of the cables and move the controls to end stop positions when lubricating. Refit the rubber covers on the cables after lubrication. Cables with sheaths will bind if they are not lubricated regularly. If a cable binds, it can disrupt operation.

If a cable binds, remove the cable and hang it vertically. Lubricate it with thin engine oil until the oil begins to escape from the bottom.

Hint!: Fill a small plastic bag with oil and tape it so that it seals against the sheath and allow the cable to hang vertically from the bag overnight. If you do not succeed in lubricating the cable, it must be replaced.

Lubricating in Accordance with the Lubrication Schedule

1. Front Wheel Mount

Lubricate with a grease gun, one zerk for each wheel mount, until the grease is forced out.

Use only good quality molybdenum disulphide grease.

Grease from well-known brand names (petrochemical companies, etc.) usually maintains a good quality.

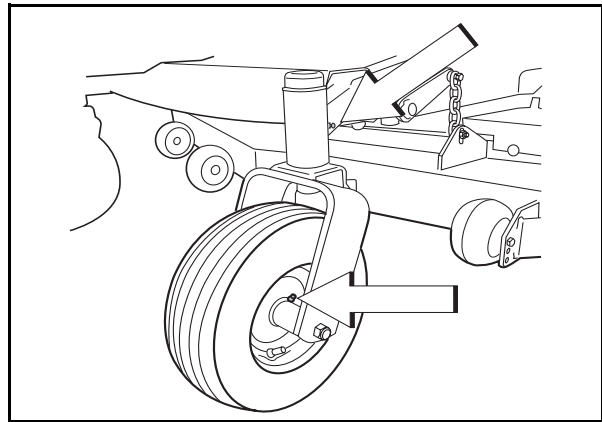

8011-573

Lubricating the front wheels

2. Front Wheel Bearings

Lubricate with a grease gun, one zerk for each set of wheel bearings, until the grease is forced out.

Use only good quality molybdenum disulphide grease.

Grease from well-known brand names (petrochemical companies, etc.) usually maintains a good quality.

3. Throttle and Choke Cables, Lever Bearings

Lubricate the cable end at the carburetor with the oil can. Move the control to the end points and lubricate again.

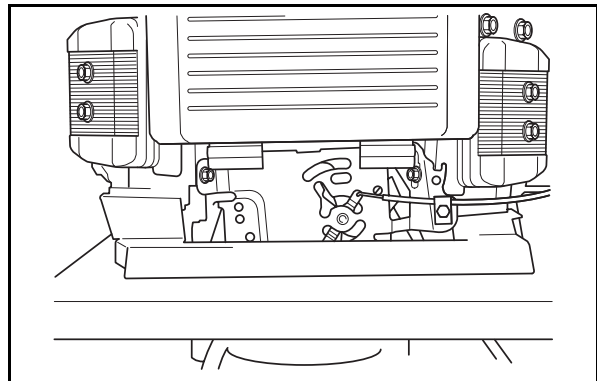

8011-485

Throttle and choke cables by the carburetor

LUBRICATION

4. Changing the Oil Filter

1. Drain the engine oil in accordance with the description under the heading Engine Oil/Change Engine Oil.
2. On Kohler engine, drain the filter by the plug at the filter base before removal.
3. Remove the oil filter. If necessary, use a filter remover.
4. Wipe new, clean engine oil onto the seal of the new filter.
5. Mount the filter by hand with + 3/4 turn.
6. Run the engine warm, then check that there are no leaks around the oil filter seal.
7. Check the oil level in the engine, fill if necessary. The oil filter holds 0.2 qt (0.2 liters) of oil.

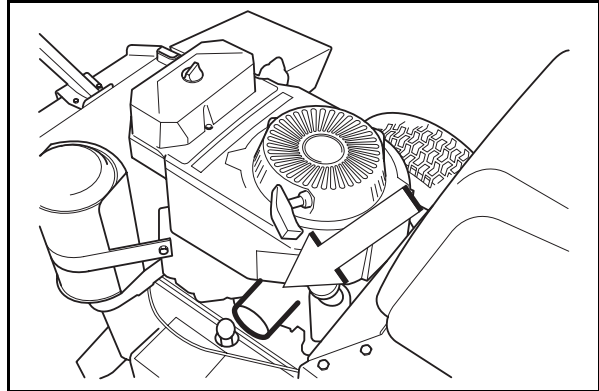

8011-785

Changing the oil filter Kawasaki engine

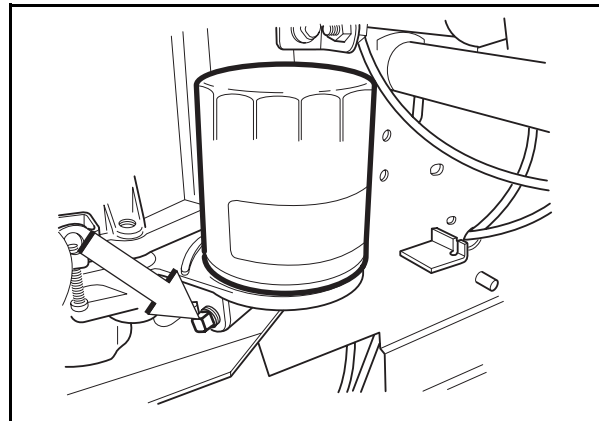

8011-792

Changing the oil filter Kohler engine

LUBRICATION

5. Engine oil

Kawasaki Engine

Changing the Engine Oil

The engine oil should be changed for the first time after 8 hours of operation. Thereafter, it should be changed every 100 hours.



WARNING!

Engine oil can be very hot if it is drained directly after stopping the engine. Allow the engine to cool somewhat first.

IMPORTANT INFORMATION

Used engine oil is a health hazard and must not be disposed of on the ground or in nature; it should always be disposed of at a workshop or appropriate disposal location.

Avoid skin contact; wash with soap and water in case of spills.

1. Place the machine on a flat surface.
2. Place a container under the engine where the hose from the oil drain valve exits.
3. Remove the dipstick and open the drain valve.
4. Allow the oil to run out into the container.
5. Then close the oil drain valve.
6. Replace the oil filter if necessary.
7. Fill with new engine oil refer to "Checking the Oil Level" on page 50.
8. Start the engine. Run it for a few seconds and re-check the oil level.

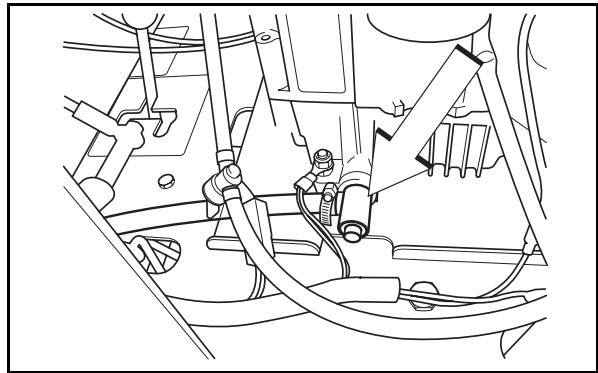

8011-451

Oil drain valve

Checking the Oil Level

Check the oil level in the engine when the machine is standing level and the engine is stopped.

Remove the dipstick, wipe it clean, and then replace it.

The dipstick should **not** be screwed into place.

Take the dipstick out again and read the oil level.

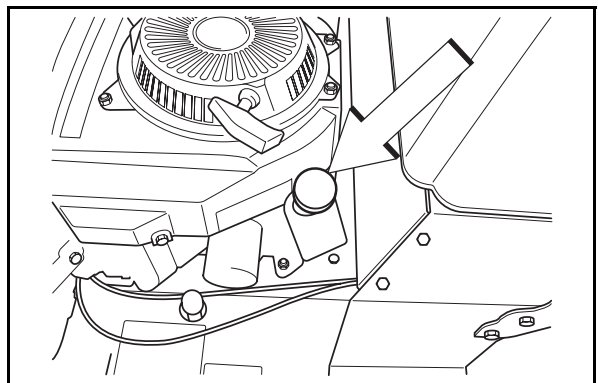

8011-452

Remove the dipstick

LUBRICATION

The oil level should lie between the markings on the dipstick. If the level is approaching the "ADD" mark, fill the oil to the "FULL" mark on the dipstick.

Never fill above the "FULL" mark.

The oil is filled through the hole for the dipstick.

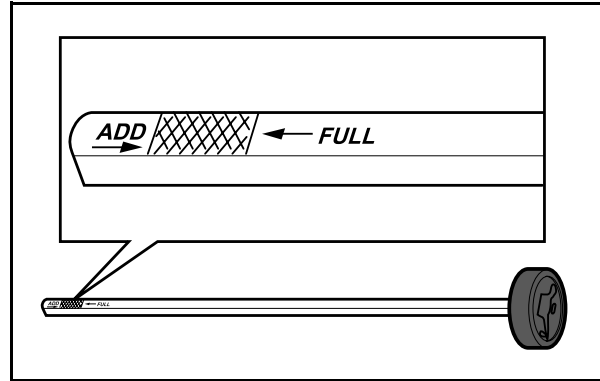

8009-159

The dipstick markings

Use engine oil SAE 30 or SAE 10W-30 or, alternately, 10W/40, class SF-SJ (over +32 °F / 0 °C).

Over +68 °F / +20 °C SAE 40 can be used.

Use engine oil SAE 5W-20, class SF-SJ (under +32 °F / 0 °C).

The engine holds 1.6 qt (1.5 liters) of oil excluding the filter (including filter 1.8 qt, 1.7 liters).

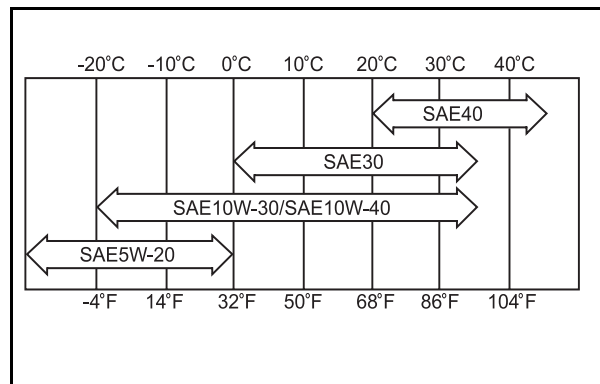

8009-140

Engine oils

LUBRICATION

Kohler Engine

Changing the Engine Oil

Change oil after every 100 hours of operation (more frequently under severe conditions). Refill with service class SG, SH, SJ or higher oil as specified in the *Viscosity Grades* table on page 54.

Change the oil while the engine is still warm. The oil will flow more freely and carry away more impurities. Make sure the engine is level when filling, checking or changing the oil.



WARNING!

Engine oil can be very hot if it is drained directly after stopping the engine. Allow the engine to cool somewhat first.

IMPORTANT INFORMATION

Used engine oil is a health hazard and must not be disposed of on the ground or in nature; it should always be disposed of at a workshop or appropriate disposal location.

Avoid skin contact; wash with soap and water in case of spills.

Change the oil as follows:

1. To keep dirt, debris, etc., out of the engine, clean the area around the oil fill cap/dipstick before removing it.
2. Remove the oil drain plugs (A) and the oil fill cap/dipstick. Be sure to allow ample time for complete drainage.
3. Reinstall the drain plugs. Make sure they are tightened.
4. Fill the crankcase, with new oil of the proper type, to the "FULL" mark on the dipstick. Refer to *Oil Type*, page 54. Always check the level with the dipstick before adding more oil.
5. Reinstall the oil fill cap/dipstick and tighten securely.

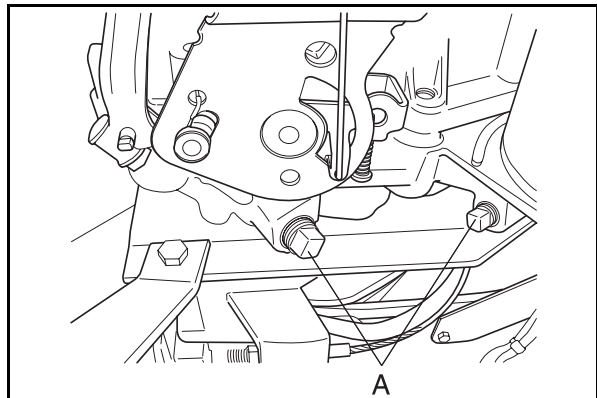

8009-465

Oil drain plugs Kohler

IMPORTANT INFORMATION

To prevent extensive engine wear or damage, always maintain the proper oil level in the crankcase. Never operate the engine with the oil level below the "ADD" mark or over the "FULL" mark on the dipstick.

6. Start the engine. Run it for a few seconds and recheck the oil level.

LUBRICATION

Checking the Oil Level

The importance of checking and maintaining the proper oil level in the crankcase cannot be overemphasized.

Check oil before each use as follows:

1. Make sure the engine is stopped, level, and is cool so the oil has had time to drain into the oil pan.
2. To keep dirt, debris, etc., out of the engine, clean the area around the dipstick before removing it.
3. Unthread and remove the dipstick; wipe oil off. Reinsert the dipstick into the tube and **rest the cap on the tube**. Do not thread the cap onto the tube.
4. Pull the dipstick out and check the oil level. The oil level should be up to, but not over, the "FULL" mark on the dipstick.

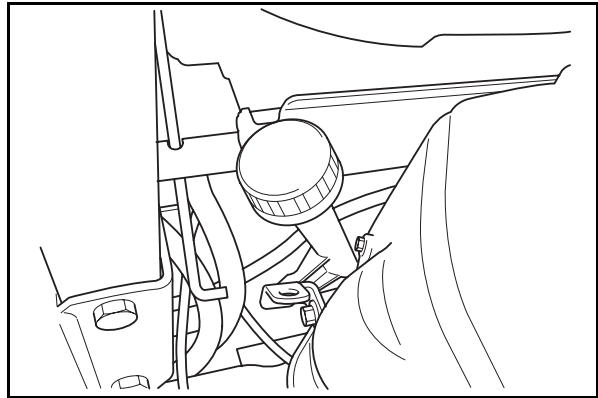

8011-471

Oil dipstick

5. If the level is low, add oil of the proper type, to the "FULL" mark on the dipstick. Refer to *Oil Type*, page 54. Always check the level with the dipstick before adding more oil.

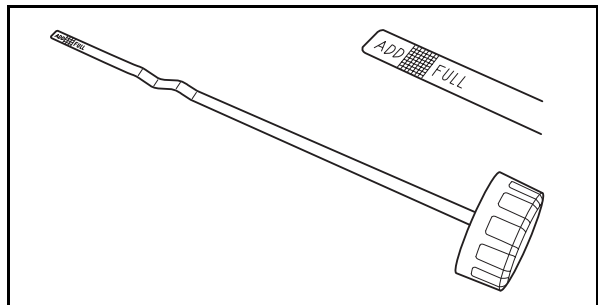

8009-464

Level marking

IMPORTANT INFORMATION

To prevent extensive engine wear or damage, always maintain the proper oil level in the crankcase. Never operate the engine with the oil level below the "ADD" mark or over the "FULL" mark on the dipstick.

LUBRICATION

Oil Recommendations

Using the proper type and weight of oil in the crankcase is extremely important. So is checking oil daily and changing oil regularly. Failure to use the correct oil, or using dirty oil, causes premature engine wear and failure.

Oil Type

Use high quality detergent oil of API (American Petroleum Institute) service class SG, SH, SJ or higher. Select the viscosity based on the air temperature at the time of operation.

IMPORTANT INFORMATION

Using other than service class SG, SH, SJ or higher oil or extending oil change intervals longer than recommended can cause engine damage.

IMPORTANT INFORMATION

Synthetic oils meeting the listed classifications may be used with oil changes performed at the recommended intervals. However to allow piston rings to properly seat, a new or rebuilt engine should be operated for at least 50 hours using standard petroleum based oil before switching to synthetic oil.

A logo or symbol on oil containers identifies the API service class and SAE viscosity grade.

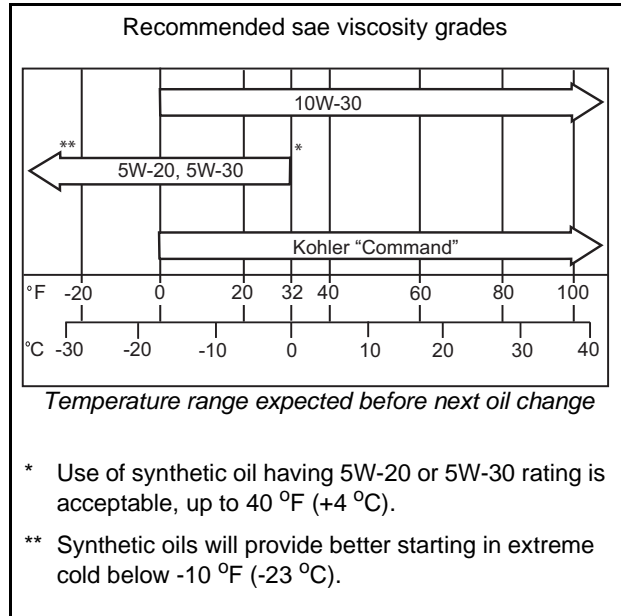

8011-766

Viscosity grades table

LUBRICATION

6. Mower deck lever

Lubricate with a grease gun, one zerk, until the grease is forced out.

Use only good quality molybdenum disulphide grease.

Grease from well-known brand names (petrochemical companies, etc.) usually maintains a good quality.

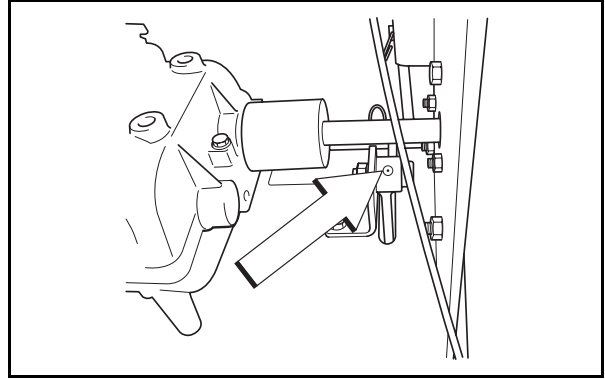

8011-715

Lubricating deck lever

7. Coupling

Lubricate with a grease gun, one zerk for each coupling, until the grease is forced out.

Use only good quality molybdenum disulphide grease.

Grease from well-known brand names (petrochemical companies, etc.) usually maintains a good quality.

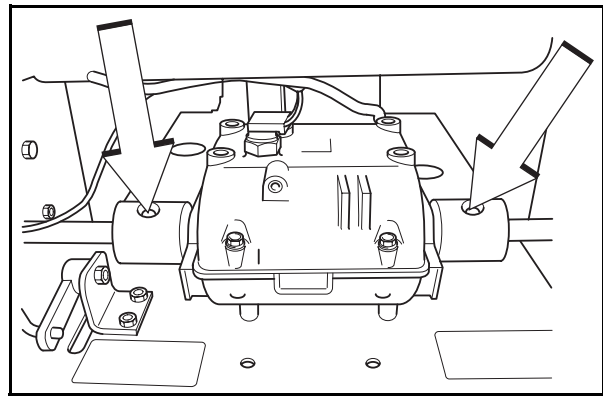

8011-494

Lubricating coupling

8. Drive wheel idler arm, right and left

Lubricate with a grease gun, one zerk for each arm, until the grease is forced out.

Use only good quality molybdenum disulphide grease.

Grease from well-known brand names (petrochemical companies, etc.) usually maintains a good quality.

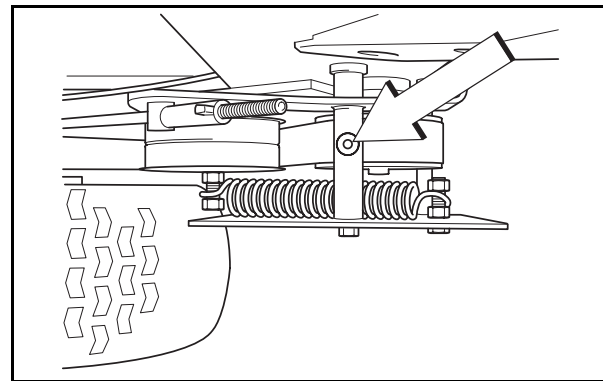

8011-495

Lubricating drive wheel

LUBRICATION

9. Rear wheels

Lubricate with a grease gun, one zerk for each wheel, until the grease is forced out.

Use only good quality molybdenum disulphide grease.

Grease from well-known brand names (petrochemical companies, etc.) usually maintains a good quality.

IMPORTANT INFORMATION

Be spartan and remove excess lubricant so that it does not come into contact with belts.

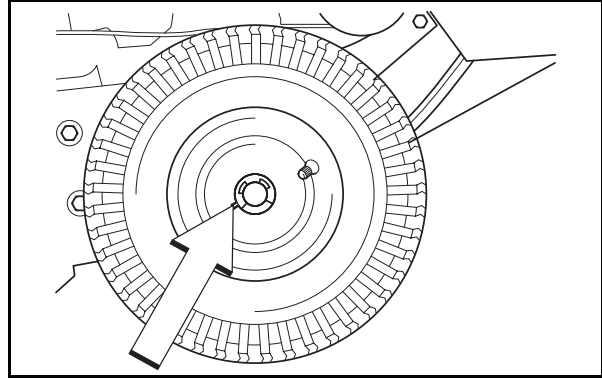

8011-716

Lubricating rear wheel

10. Brake Arms

Lubricate with a grease gun, one zerk for each brake arm, until the grease is forced out.

Use only good quality molybdenum disulphide grease.

Grease from well-known brand names (petrochemical companies, etc.) usually maintains a good quality.

IMPORTANT INFORMATION

Be spartan and remove excess lubricant so that it does not come into contact with the brake lining.

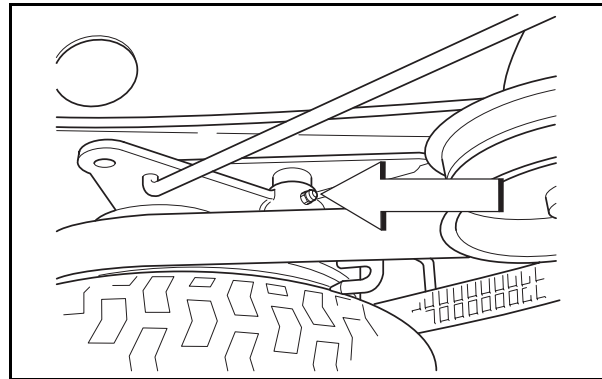

8011-493

Lubricating brake arms

TROUBLE SHOOTING GUIDE

Trouble Shooting Guide

Problem	Cause
The engine will not start.	<ul style="list-style-type: none">• The control for engaging the mower deck is in engaged position.• The motion controls are not locked in the neutral position.• Spark plug wires off.• Contamination in the carburetor or fuel line.• The fuel shut off valve is closed.• Clogged fuel filter or fuel line.• Fuel tank empty.
The engine runs unevenly.	<ul style="list-style-type: none">• Faulty carburetor.• The choke control is pulled out with a warm engine.• Defective valves.• Defective piston, cylinder, piston ring, or cylinder head seal.• The cylinder head bolts are loose.• Clogged fuel filter or jet.• Clogged ventilation valve on the fuel cap.• Fuel tank near empty.• Defective spark plugs.• The spark plugs are loose.• Defective ignition cable.• Defective spark plug electrode.• Defective spark plug connection.• Rich fuel mixture or fuel-air mixture.• Wrong fuel type.• Water in the fuel.• Clogged air filter.
The engine seems weak.	<ul style="list-style-type: none">• Clogged air filter.• Defective spark plugs.• Carburetor incorrectly adjusted. Worn engine.

TROUBLE SHOOTING GUIDE

The engine overheats.

- Clogged air intake or cooling fins.
- Engine overloaded.
- Poor ventilation around engine.
- Defective engine speed regulator.
- Too little or no oil in the engine.
- Defective spark plugs.

The machine moves slowly, unevenly,

- Drive belt for the gear slack or has come off.

Mower deck not engaging.

- Drive belt for the mower deck has come loose.
- Contact for the electromagnetic coupling has loosened.
- The control for engaging the mower deck is faulty or has come loose from the cable contact.

Uneven mowing results.

- Different air pressure in the tires on the left and right sides.
- Bent blades.
- Spacers for height adjustment faulty placed.
- The blades are blunt.
- Driving speed too high.
- The grass is too long.
- Grass collected under the mower deck.

The machine vibrates.

- The blades are loose.
- The blades are incorrectly balanced.
- The engine is loose.

The machine moves when in neutral position.

- The motion control linkage out of adjustment.

The machine pulls left or right.

- The tire pressure uneven.
- The motion control linkage incorrectly adjusted.
- Soft terrain.
- Slope too steep.
- The tracking not adjusted.
- Brakes faulty adjusted.

STORAGE

Storage

Winter Storage

At the end of the mowing season, the machine should be readied for storage (or if it will not be in use for longer than 30 days). Fuel allowed to stand for long periods of time (30 days or more) can leave sticky residues that can plug the carburetor and disrupt engine function.

Fuel stabilizers are an acceptable option to prevent sticky residues during storage. Add stabilizer to the fuel in the tank or in the storage container. Always use the mixing ratios specified by the manufacturer of the stabilizer. Run the engine for at least 10 minutes after adding the stabilizer so that it reaches the carburetor. Do not empty the fuel tank and the carburetor if you have added stabilizer.



WARNING!

Never store an engine with fuel in the tank indoors or in poorly ventilated spaces where fuel vapor can come in contact with open flames, sparks, or a pilot light such as in a boiler, hot water heater, clothes drier, etc. Handle the fuel with care. It is very flammable and careless use can cause serious personal injury and property damage. Drain the fuel into an approved container outdoors and far away from open flame. Never use gasoline for cleaning. Use a degreaser and warm water instead.

To ready the machine for storage, follow these steps:

1. Thoroughly clean the machine, especially under the mower deck. Touch up damage to the paint and spray a thin layer of oil on the underside of the mower deck in order to avoid corrosion.
2. Inspect the machine for worn or damaged parts and tighten any nuts or screws that may have become loose.
3. Change the engine oil; dispose of properly.
4. Empty the fuel tanks or add a fuel stabilizer. Start the engine and allow it to run until even the carburetor is drained of fuel or the stabilizer has reached the carburetor.
5. Remove the spark plugs and pour about a tablespoon of engine oil into each cylinder. Turn over the engine so that the oil is evenly distributed and then refit the spark plugs.
6. Lubricate all grease zerks, joints, and axles.
7. Store the machine in a clean, dry place and cover it for extra protection.

Service

When ordering spare parts, please specify the purchase year, model, type, and serial number.

Always use genuine Husqvarna spare parts.

An annual check-up at an authorized service workshop is a good way to ensure that your machine performs its best the following season.

TECHNICAL DATA

Technical data

	WG3213P	WG3613P	WG4815P
Engine			
Manufacturer	Kohler	Kohler	Kawasaki
Type	CV13	CV13	FH430V
Power	13 hp / 9.5 kW	13 hp / 9.5 kW	15 hp / 11 kW
Spark plugs / gap	Champion RC12YC / .030" / 0.75 mm	Champion RC12YC / .030" / 0.75 mm	RCJ8Y/ .030" / 0.75 mm
Oil capacity excl filter	1.9 qt. / 1.8 liters	1.9 qt. / 1.8 liters	1.6 qt / 1.5 liters
Oil capacity incl filter	2 qt. / 1.9 liters	2 qt. / 1.9 liters	1.8 qt / 1.7 liters
Engine oil (See viscosity digram)	SAE 10W30 API SG-SJ	SAE 10W30 API SG- SJ	SAE 10W30, 10W40 SAE 30, SAE 40 API SF-SJ
Fuel	Min 87 octane unleaded (Max etyhl alcohol 10%, Max MTBE 15%)	Min 87 octane unleaded (Max etyhl alcohol 10%, Max MTBE 15%)	Min 87 octane unleaded (Max methanol 5%, max ethanol 10%, Max MTBE 15%)
Fuel tank capacity	5.3 gallon / 20 liters	5.3 gallon / 20 liters	5.3 gallon / 20 liters
Transmission			
Transmission	Peerless 5 speed, 700 series, 9 spline		Peerless 5 speed, 700 series, 9 spline
Speed forward	2.0-6.0 mph / 3.2-9.6 km/h	2.0-6.0 mph / 3.2-9.6 km/h	2.0-6.0 mph / 3.2-9.6 km/h
Speed reverse	Assisted only	Assisted only	Assisted only
Front caster tires, Smooth tread	9x3.50-4, 4 ply	9x3.50-4, 4 ply	9x3.50-4, 4 ply
Rear tires, Turf pneumatic	13x5.0-6	13x6.5-6	13x6.5-6
Tire pressure front and rear	15 PSI / 103 kPa / 1 bar	15 PSI / 103 kPa / 1 bar	15 PSI / 103 kPa / 1 bar
Equipment			
Cutting width	32" / 81 cm	36" / 91 cm	48" / 122 cm
Cutting height	1.5" - 5" / 38 - 127 mm	1.5" - 5" / 38 - 127 mm	1.5" - 5" / 38 - 127 mm

TECHNICAL DATA

	WG3213P	WG3613P	WG4815P
Productivity			
Productivity	1.6 acres/h / 6480 m ² /h	1.8 acres/h / 7290 m ² /h	2.4 acres/h / 9720 m ² /h
Overall dimensions			
Weight	370 lbs / 168 kg	445 lbs / 202 kg	470 lbs / 213 kg
Base machine length	66" / 168 cm	66" / 168 cm	66" / 168 cm
Base machine width	37" / 94 cm	49" / 125 cm	49" / 125 cm
Base machine height	42" / 106 cm	42" / 106 cm	42" / 106 cm
Overall width, Chute up	33" / 84 cm	37" / 94 cm	49" / 125 cm
Overall width, Chute down	43" / 109 cm	47" / 119 cm	59" / 150 cm

TECHNICAL DATA

Torque Specifications

Engine crankshaft bolt	50 ft/lb(67 Nm)
Deck pulley bolts	45 ft/lb (61 Nm)
Blade bolt	90 ft/lb (122 Nm)
Standard ¼" fasteners	9 ft/lb (12 Nm)
Standard 5/16" fasteners	18 ft/lb (25 Nm)
Standard 3/8" fasteners	33 ft/lb (44 Nm)
Standard 7/16" fasteners	52 ft/lb (70 Nm)
Standard ½" fasteners	80 ft/lb (110 Nm)

When this product is worn out and no longer used, it should be returned to the dealer or other party for recycling.

In order to implement improvements, specifications and designs can be altered without prior notification.

Note that no legal demands can be placed based on the information contained in these instructions.

Use only original parts for repairs. The use of other parts voids the warranty.

Do not modify or install non-standard equipment to the unit without consent from the manufacturer. Modifications to the unit may cause unsafe operation or damage the unit.

WIRING DIAGRAMS

Wiring diagram

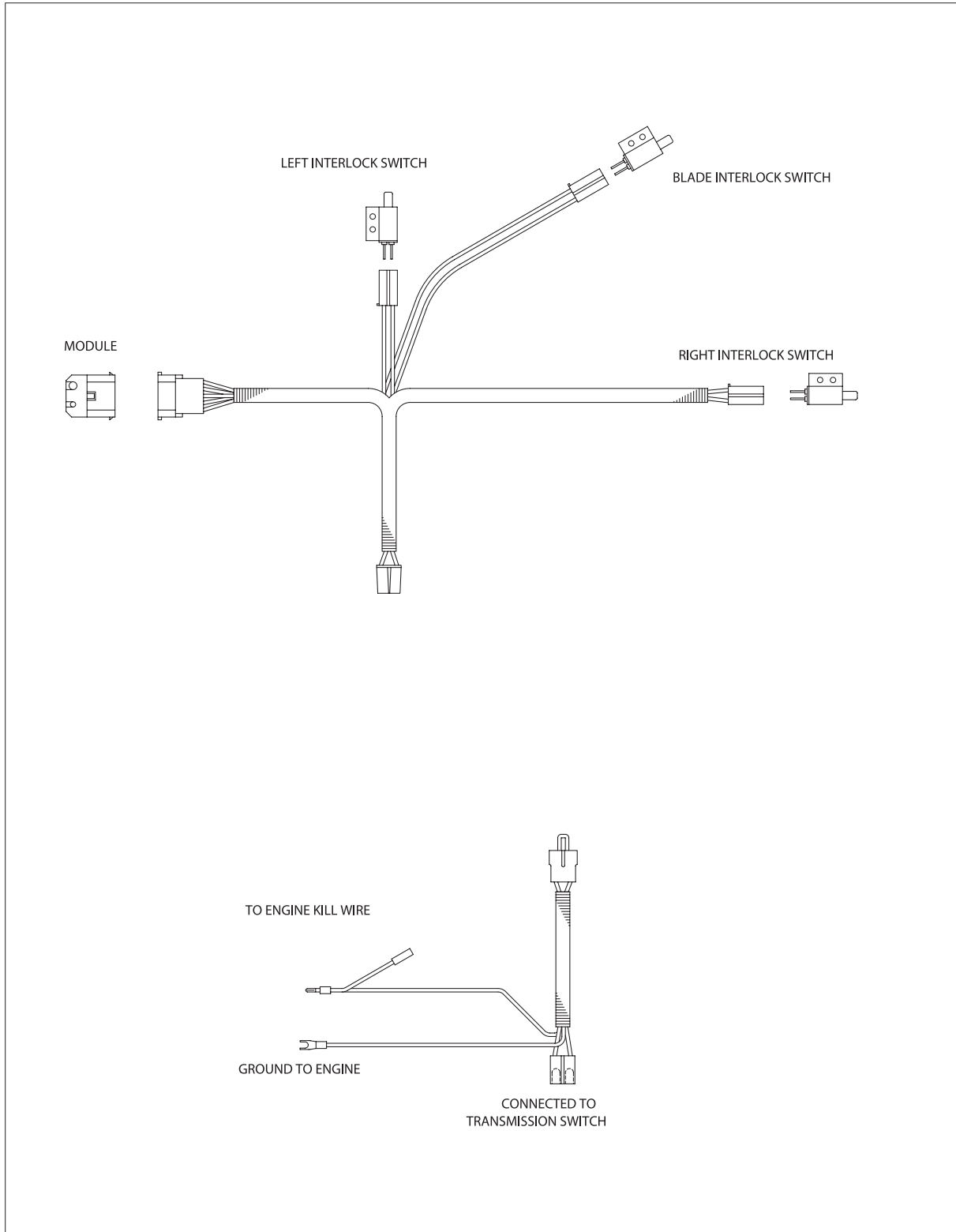

8011-695

CONFORMITY CERTIFICATES

Conformity Certificates

USA requirements

Labels are placed on the engine and/or in the engine compartment stating that the machine will fulfill the requirements. This is also applicable to special requirements for any of the states, (Californian emission rules etc.). Do not remove any of these labels. Certificates can also be supplied with the machine at delivery or written in the Engine manual. Take care of them as valuable documents.

SERVICE JOURNAL

Action	Date, mtr reading, stamp, sign
<p>25-Hour Service</p> <ol style="list-style-type: none">1. Check the fuel pump's air filter (Kawasaki engine).2. Check the tire pressures and tire damage.3. Check/clean the engine's cooling air intake.4. Clean the air cleaner's pre-filter (foam).5. Check the cutting deck.	

SERVICE JOURNAL

Action	Date, mtr reading, stamp, sign
<p>50-Hour Service</p> <ol style="list-style-type: none">1. Perform the 25-hour service.2. Clean/replace the air cleaner's filter cartridge (paper filter) (shorter intervals for dusty operating conditions).3. Lubricate the front wheel bearings.4. Lubricate the throttle/choke cable.5. Check/adjust the parking brake.	

SERVICE JOURNAL

Action	Date, mtr reading, stamp, sign
<p>100-Hour Service</p> <ol style="list-style-type: none">1. Perform the 25-hour service.2. Perform the 50-hour service.3. Change engine oil.4. Check whether the engine oil filter needs changing (every 200 hours).5. Clean/replace the spark plugs.6. Replace the fuel filter.7. Clean the cooling fins on the engine and transmission.8. Check V-belts, pulleys etc.9. Check tighten caster wheel axle bolts (every 200 hours).10. Clean and check the need to change the air filter's paper cartridge (every 200 hours).	

SERVICE JOURNAL

Action	Date, mtr reading, stamp, sign
<p>300-Hour Service</p> <ol style="list-style-type: none">1. Inspect the machine. Come to agreement with the customer as to which additional work is to be carried out.2. Perform the 25-hour service.3. Perform the 50-hour service.4. Perform the 100-hour service.5. Clean the combustion chamber and grind the valve seats.6. Check the engine valve clearance.7. Replace the air cleaner's pre-filter (foam).	

SERVICE JOURNAL

Action	Date, mtr reading, stamp, sign
<p>At Least Once Each Year</p> <ol style="list-style-type: none">1. Clean the engine's cooling air intake (25 hours).2. Replace the air cleaner's pre-filter (Oil-foam) (300 hours).3. Replace the air filter's paper cartridge (200 hours).4. Change the engine oil (100 hours).5. Replace the engine oil filter (200 hours).6. Check/adjust the cutting height.7. Check/adjust the parking brake (50 hours).8. Clean/Change the spark plugs (100 hours).9. Change the fuel filter (100 hours).10. Clean the cooling fins (100 hours).11. Check the play in the engine valves (300 hours).12. Perform the 300-hour service at an authorized service workshop.	

