

Collection System

Operators Manual
Parts Manual

Models: 111750 / HCS1372

Please read these instructions carefully and make sure you understand them before using the machine.

MANUAL NO. 539111758 REV 01 (03/31/05)

INDEX

Operators Guide

Features and Controls	4
General Information	5
Safety Procedures	5
Unpacking Instructions	7
Assembly Instructions	7
Collection System	7
Blower/Drive Kit	11

Operating the Collection System	12
--	-----------

Maintenance and Service Instructions

Transport	13
Cleaning and Washing	13
Storage	13
Preventative Maintenance Schedule	13
Caring for Vacuum Hoses	14
Cleaning Poly Mesh	14
Caring for Bags	14
Troubleshooting Guide	15

Replacement Parts

Hood Assembly	18
Hitch Assembly	19
Blower Assembly	20
Weight Kit	22
Mounting Kit	23
Bag Assembly	24
Drive Kit	25
Parts Description	26

WARNING: Engine exhaust, some of its constituents, and certain vehicle components contain or emit chemicals known to the State of California to cause cancer and birth defects or other reproductive harm.

FEATURES & CONTROLS

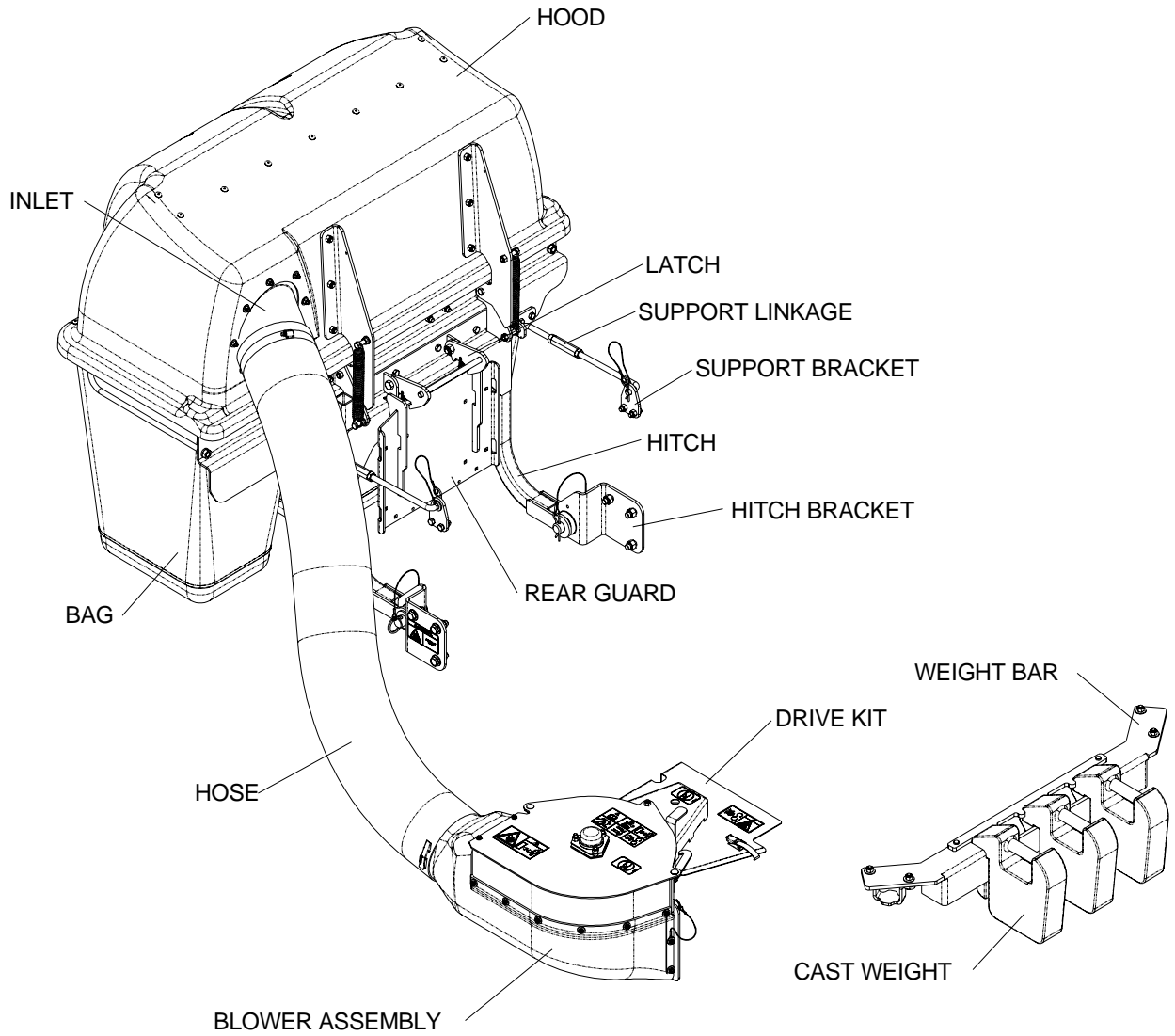

NOTE: Your Front Weight Bar may look different from those shown in this diagram.

SAFETY RULES

General Information

This manual will assist you in the safe operation and proper maintenance of your Husqvarna equipment. Read it thoroughly before attempting to operate the machine. Call your dealer or Husqvarna if additional information is required.

The following safety symbols are used throughout the manual to alert you to information about unsafe actions or situations:



DANGER indicates immediate hazards that may result in severe injury or death.



WARNING indicates unsafe actions or situations that may cause severe injury, death, and/or major equipment or property damage.



CAUTION indicates unsafe actions or situations that may cause injury and/or minor equipment or property damage.

This equipment should not be modified without the manufacturer's prior written authorization. Doing so may not only affect the equipments' performance and durability, but also create safety hazards for the operator and the surroundings. Warranty will be void if changes are made to the equipment without the manufacturer's prior written authorization.

Safety Procedures

1 - Training:

- Read the Operator's manual. If the operator(s) or mechanic(s) can not read English it is the owner's responsibility to explain this material to them.
- Become familiar with the safe operation of the equipment, operator's controls, and safety signs.
- All operators and mechanics should be trained. The owner is responsible for training the users.
- Never let children or untrained people operate or service the equipment. Local regulations may restrict the age of the operator.
- The owner/user can prevent and is responsible for accidents or injuries occurring to themselves, other people, and/or property.

2 - Preparation:

- Wear appropriate clothing including hard hat, safety glasses and ear protection. Long hair, loose clothing or jewelry may get tangled in moving parts.
- Inspect the area where the equipment is to be used and remove all objects such as rocks, toys and wire which can be thrown by the machine.
- Use extra care when handling gasoline and other fuels. They are flammable and vapors are explosive. Use only an approved container. Never remove gas cap or add fuel with engine running. Allow engine to cool before refueling. Do not smoke while fueling or operating equipment. Never refuel or drain the machine indoors.
- Check that operator's controls, safety switches, hoses, and shields are securely attached and functioning properly. Do not operate unless they are functioning properly.

SAFETY RULES

3 - Operation

- Never run an engine in an enclosed area.
- Only operate in good light, keeping away from holes and hidden hazards.
- Slow down and use extra care on hillsides. Make turns gradually and at slow speed. Do not operate across the sides of slopes. Operate up and down slopes only. Do not operate on steep slopes.
- Turf conditions can affect the machine's stability. Do not operate on wet grass where traction may be reduced.
- Do not change the engine governor setting or overspeed the engine.
- Stop equipment and inspect vacuum impeller and hoses after striking objects or if an abnormal vibration occurs. Make necessary repairs before resuming operations.
- Look behind and down before backing up to ensure a clear path.
- Slow down and use caution when making turns and crossing roads and sidewalks. Stop vacuum and mower blades if not mowing.
- Do not operate machine under the influence of alcohol or drugs.

- Use care when loading or unloading the machine into a trailer or truck.
- Use care when approaching blind corners, shrubs, trees, or other objects that may obscure vision.

4 - Maintenance and Storage:

- Stop engine and disconnect spark plug wire. Wait for all movement to stop before adjusting, cleaning, or repairing.
- Clean grass and debris from muffler and engine to help prevent fires. Clean up oil or fuel spillage.
- Let engine cool before storing and do not store near sparks or open flame.
- Shut off fuel while storing. Do not store fuel near flames or drain indoors.
- Never allow untrained personnel to service machine.
- Keep hands and feet away from moving parts. If possible, do not make adjustments with the engine running.
- Keep all parts in good working condition and all hardware tightened. Replace all worn or damaged decals.

ASSEMBLY

Unpacking Instructions

1. Cut plastic tie securing the hitch to the crate top.
2. Remove the top of the crate.
3. Remove the plastic bag.
4. Remove the hose.
5. Remove the sides and ends of the crate.
6. Remove the mounting kit and drive kit boxes from the corner of the crate.
7. Cut the two plastic ties that secure the hitch assembly to the pallet. Remove the hitch assembly.
8. Cut the two plastic ties that secure the back of the hood, and the two that secure the front of the hood. Remove the hood assembly.
9. Cut and two plastic ties that secure the weight bar to the pallet. Remove the weight bar.
10. Cut the two plastic ties that secure the blower assembly to the pallet. Remove the blower assembly.
11. Remove the 1 x 4 that secures the cast weights to the pallet. Remove the weights.

Assembly Instructions

Collection System

Tools Required:

Ratchet	9/16" Socket
Torque Wrench	5/8" Socket
1/2" Wrench	(2) 3/4" Wrench
1/2" Socket	3/4" Socket
9/16" Wrench	Flat Screw Driver

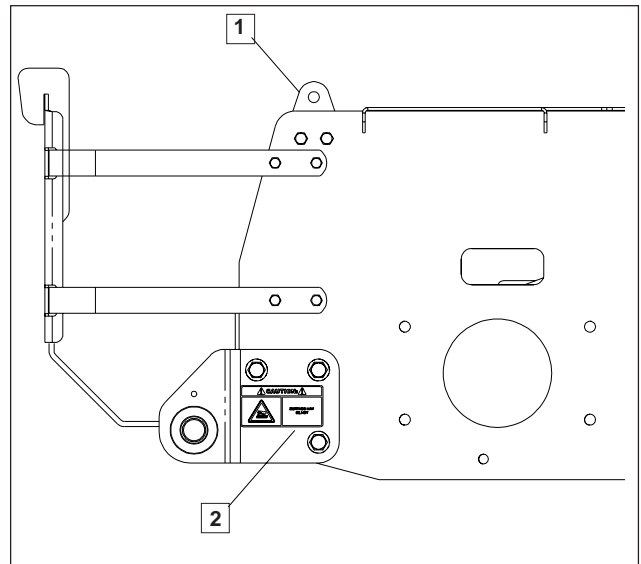

FIGURE 1

1. SUPPORT BRACKET
2. HITCH BRACKET

1. Open the mounting kit box and remove all of the components.
2. Place the support bracket on the frame and secure with (2) 990563, 3/8 x 1 bolts and (2) 976979, 3/8 nyloc nuts. Figure 1.
3. Place the hitch brackets on the frame and secure with (3) 990622, 1/2 x 1 1/4 bolts and (3) 101331, 1/2 nyloc nuts. Figure 1.

ASSEMBLY

4. Remove the (10) 5/16 carriage bolts that secure the standard rear guard to the straps and skid plates. Remove the standard rear guard. Replace with the collection rear guard, and secure with the carriage bolts that were just removed. Figure 2.

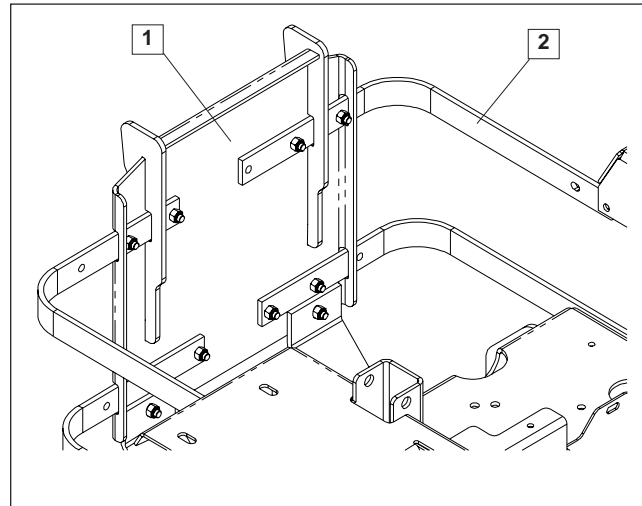
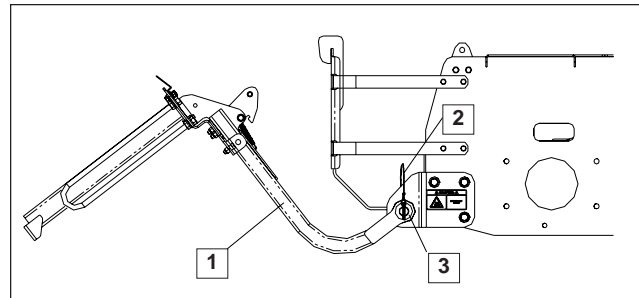

FIGURE 2

1. REAR GUARD
2. STRAP

5. Place the hitch assembly on the ground behind the mower. Place the (2) hitch pins thru the hitch and the hitch brackets. Secure the hitch pins with the (2) hairpins that are secured with the (2) lanyards. Figure 3.



6. Move to the rear of the hitch assembly and pick it up towards the rear guard. The latch will hook over the top of the rear guard. Figure 3.

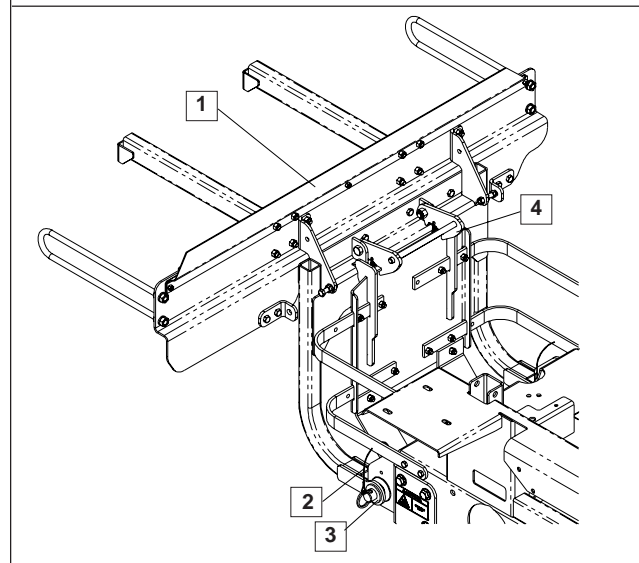

FIGURE 3

1. HITCH ASSEMBLY
2. LANYARD
3. HITCH PIN
4. LATCH

ASSEMBLY

7. Place the hood assembly on to the hitch assembly. Place both hood hinges between the upper hitch mounts on the hitch assembly. Be sure that the rubber seal is on the inside of the hood. Place the (2) friction washers between the hood hinge and the upper hitch mount. Place the (2) 990563, 3/8 x 1 bolt thru the hinge and mount. Secure with (2) 976979, 3/8 nyloc nut. Figure 4.
8. Open the hood and secure the (2) springs to the bolts on the hood assembly and the hitch assembly. Figure 4.

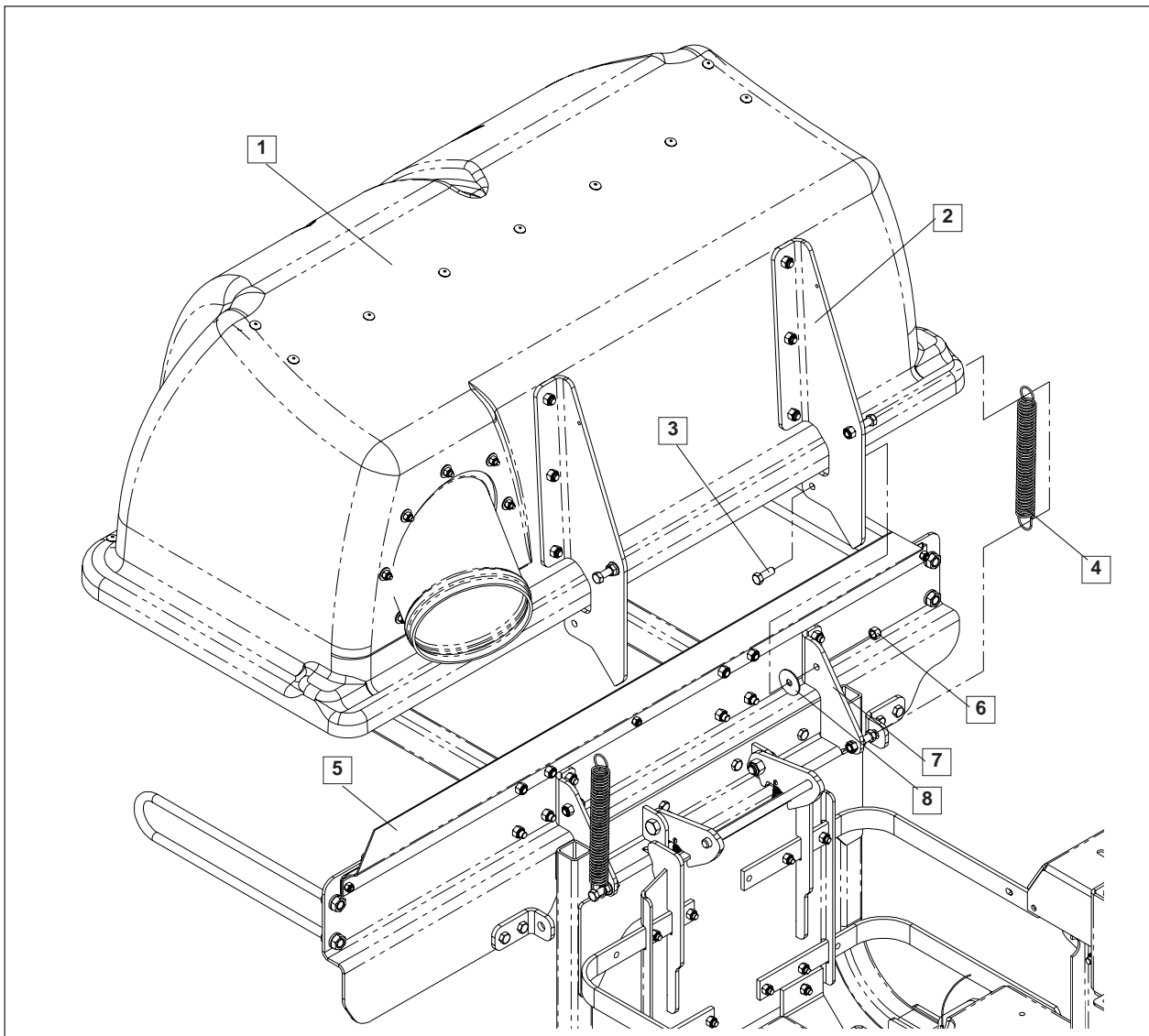

FIGURE 4

- | | |
|------------------|----------------------|
| 1. HOOD ASSEMBLY | 5. RUBBER SEAL |
| 2. HOOD HINGE | 6. 3/8 NYLOC NUT |
| 3. 3/8 X 1 BOLT | 7. UPPER HITCH MOUNT |
| 4. SPRING | 8. HITCH PIN |

ASSEMBLY

9. With the hood open, secure the (3) bags in place. The back of the bags will hook over the mounting tabs on the hitch assembly. Figure 5.
10. Close the hood, and latch the draw latch over the draw latch keeper on the hitch assembly. Figure 5.

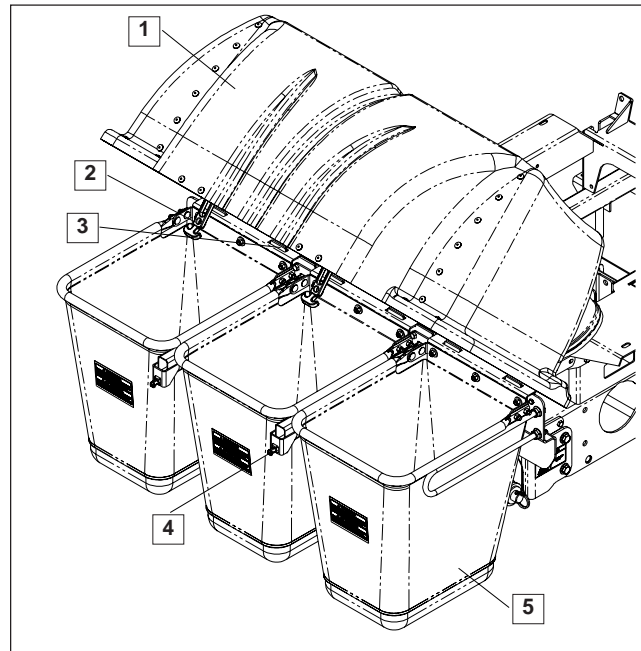

FIGURE 5

1. HOOD ASSEMBLY
2. DRAW LATCH
3. MOUNT TABS
4. DRAW LATCH KEEPER
5. BAG

11. Install the (2) linkage assemblies to the (2) support brackets on hitch assembly and the (2) support brackets on the frame. The shorter linkage connects to the support bracket on the hitch assembly. Figure 6.

NOTE: The linkage assemblies may need to be adjusted. Using (2) 3/4" wrenches, loosen the 1/2" jam nut on the longer linkage. Turn the turnbuckle in the appropriate direction to shorten the linkage assembly. Turn until the slop is taken out of the linkages. Tighten the jam nut against the turnbuckle.

12. Secure the front of the linkage assemblies using the hairpin secured by the lanyard. Secure the rear of the linkages using the (2) 990654, cotter pins provided. Figure 6.
13. Place the hose on the inlet and secure with the hose clamp.

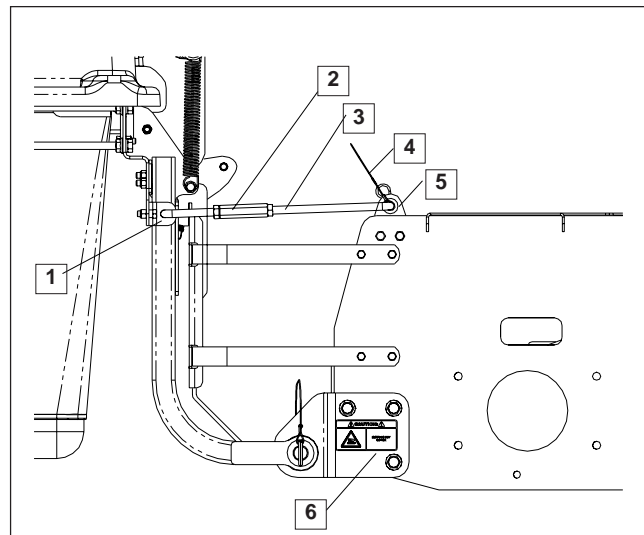

FIGURE 6

1. SUPPORT BRACKET
2. TURNBUCKLE
3. LINKAGE ASSEMBLY
4. LANYARD
5. SUPPORT BRACKET
6. HITCH BRACKET

ASSEMBLY

Blower/Drive Kit

1. Open the drive kit box and remove all of the components.
2. Place the deck in the lowest cutting height.
3. Remove the right side belt shield from the deck.
4. Remove the deck belt from the right side pulley.
5. Remove the deck pulley.

Note: When the deck pulley is removed, the spindle can fall out of the cutter housing assembly. Be sure to secure the bottom of the spindle so that this does not happen.

6. Place the double pulley on the cutter housing assembly.
7. Place the heavy washer, and 7/16 lock washer on the 108951, 7/16 x 2 1/2 bolt and install in the spindle. Torque to 45 ft/lbs.
8. Remove the discharge chute from the deck. Verify that the belt is on the pulley in the blower.
9. Place the deck plate pin in the tube on the back edge of the deck. Rotate the blower around and into place. Figure 1.
10. Install the pin thru the tabs on both the deck and the blower. Figure 1.
11. Latch the idler arm in the idler keeper. Figure 1.
12. Install the belt on the deck pulley and release the idler arm from the keeper.
13. Install the new belt shield.
14. Place the hose on the blower housing and secure with the over center hose clamp.

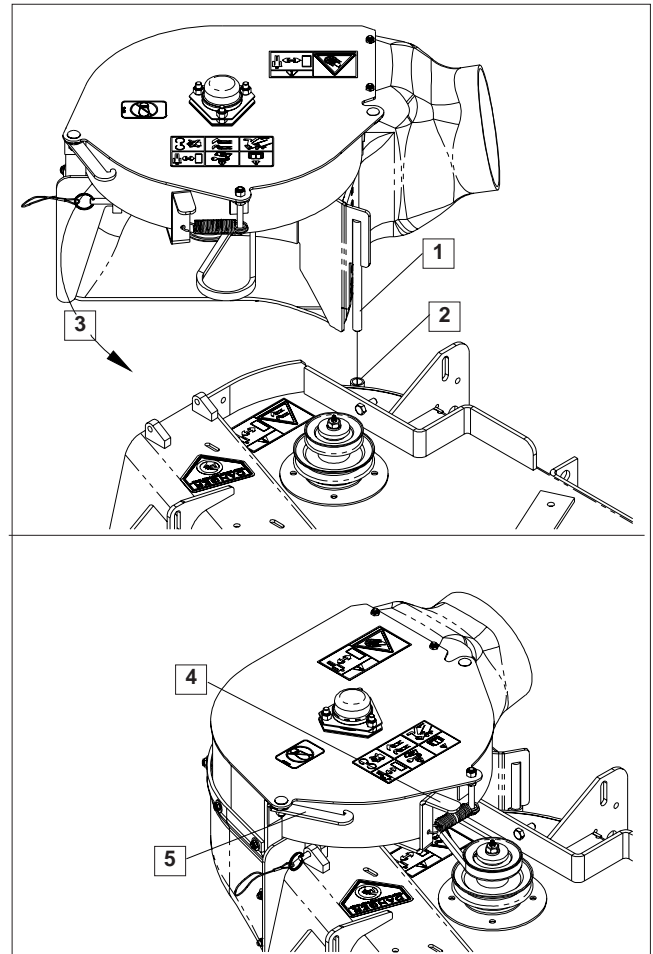

FIGURE 1

1. DECK PLATE PIN
2. TUBE
3. ROTATE
4. IDLER ARM
5. IDLER KEEPER

OPERATION

Operating the Collection System

1. **NEVER USE THE COLLECTION SYSTEM WITHOUT THE BLOWER ASSEMBLY AND HOSES SECURELY ATTACHED.**
2. Make sure hoses are connected at both ends. Inspect hoses prior to each use.
3. Do not use the unit on slopes greater than 10 degrees.
4. The mower must be running in order to vacuum debris through the mower deck.
5. In heavy grass it may be necessary to mow and collect at a slower ground speed.
6. Never attempt to unclog the collection system until the mower's engine has been shut off and all moving parts have come to a complete stop.
7. Do not stand behind the vent at the rear of the collection system due to the potential for small pieces of blowing debris to escape through the vent.
8. Wear eye and ear protection.

SERVICE AND MAINTENANCE

Transport



WARNING

The collection system bags must be completely empty or removed while driving forward onto a trailer. If the mower must be loaded onto a trailer while there is still debris in the container, the mower must be backed up onto the trailer to avoid tipping.

For best results, clean poly mesh inside hood regularly. Instructions for doing this can be found in the Service section of this manual.

Cleaning and Washing

Regular cleaning, washing, and lubricating will prolong the service of the machine.

NOTE: Use care with power washers to avoid damage to decals. Limit direct spray on these items.

DO NOT EXCEED 1000 PSI WATER PRESSURE FOR CLEANING.

Storage

1. Clean machine.
2. Cover all scratches with touch-up paint.
3. Covered or indoor storage is recommended.

Preventative Maintenance Schedule

Item	Before Each Use	Every 5 Hours	Every 25 Hours	Every 50 Hours
Inspect/Clean Poly Mesh	X	X		
Check/Tighten Nuts & Bolts	X			
Check/Tighten Hoses	X			
Turn Hose End to End			X	
Rotate Hose				X
Clean Machine				X
Inspect Bags	X			

SERVICE AND MAINTENANCE

Caring For Hoses

1. Inspect hoses before each use. If hoses have excessive wear, tears, or punctures, replace immediately.
2. To prolong the life of the hose, periodically rotate hose and turn hose end to end. Refer to Preventative Maintenance Schedule in this manual.
3. Avoid twists and sharp turns in the hoses, as they will increase wear on the hoses.
4. Avoid dragging the lower hose along the sides of buildings or other hard surfaces.

Cleaning Poly Mesh

The poly mesh on the collection system is located inside the container hood. For best results, clean poly mesh regularly.

Cleaning Instructions

1. Shut off engine.
2. Release the two (2) rubber latches under the rear of the hood. Open hood and brush debris off of both sides.
3. Close hood and re-latch.

DO NOT USE THE COLLECTION SYSTEM WITHOUT POLY MESH SECURELY IN PLACE.

Caring For Bags

Inspect the bags before each use. If bags have excessive wear, tears or punctures, replace immediately.

Cleaning Instructions

NOTE: Under normal usage the bag material is subject to deterioration and wear.

SERVICE AND MAINTENANCE

Troubleshooting Guide



DANGER

Before servicing unit, wait for all moving parts to come to a complete stop. Turn engine off and remove the spark plug wire.

PROBLEM	POSSIBLE CAUSE	CORRECTION
Loss of Vacuum.	<ol style="list-style-type: none">1. Blower, hose or hood inlet clogged.2. Bags full.3. Fan blades bent or broken.4. Poly mesh plugged.	<ol style="list-style-type: none">1. Remove hose and clean inlet.2. Inspect and empty.3. Replace/repair impeller.4. Clean poly mesh.
Unusual vibration or noise.	<ol style="list-style-type: none">1. Solid object jammed in unit.2. Loose or missing bolts on unit.3. Bent or damaged fan.	<ol style="list-style-type: none">1. Check and remove any obstruction.2. Tighten or replace bolts.3. Replace/repair impeller.
Unit difficult to close.	<ol style="list-style-type: none">1. Obstructions keeping door from completely closing.2. Hood hinge bolts too tight.	<ol style="list-style-type: none">1. Clear obstructions.2. Loosen bolts.

SPINDLE DRIVE ASSEMBLY

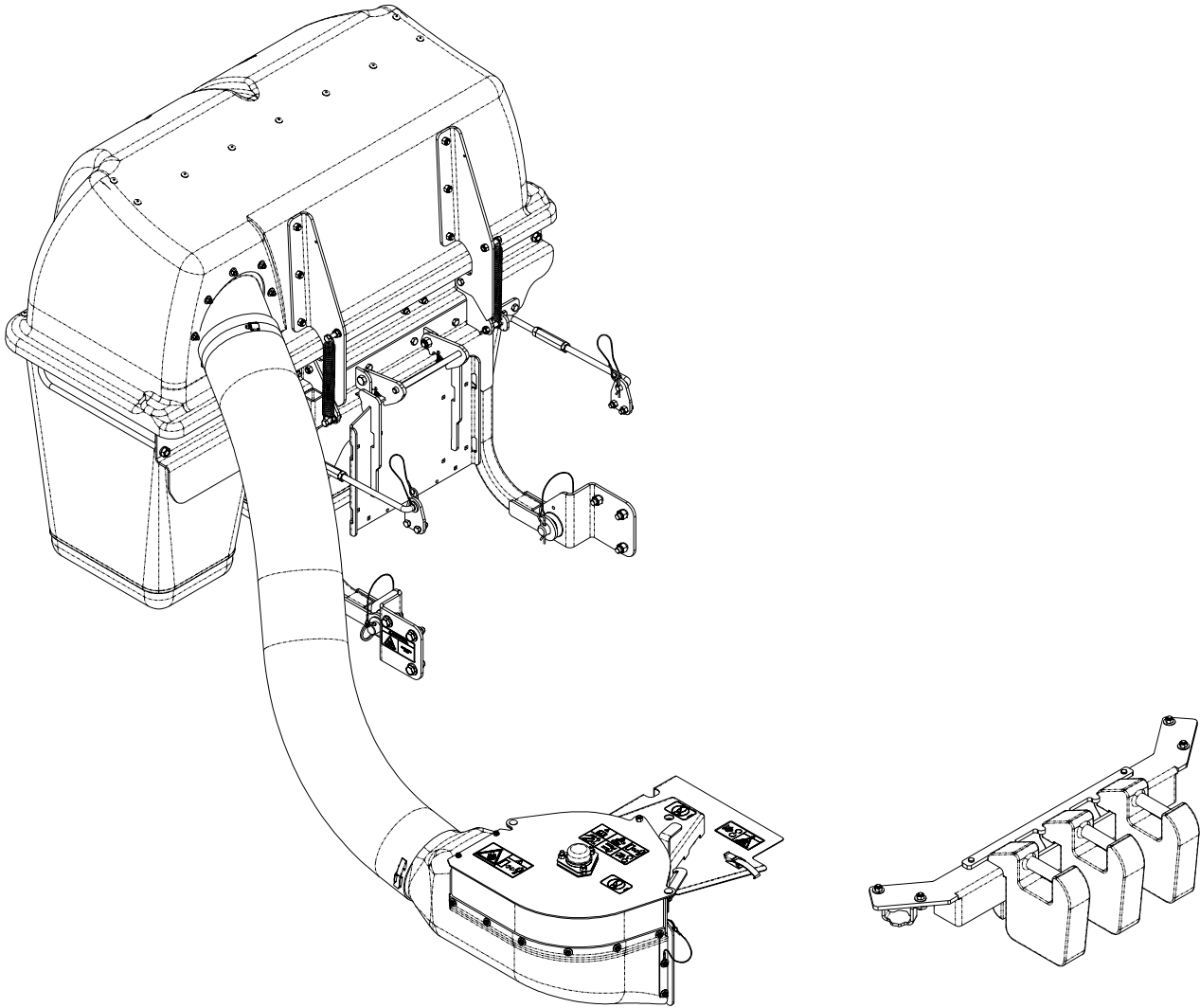

NOTE: Your Front Weight Bar may look different from those shown in this diagram.

PARTS ILLUSTRATIONS

HOOD ASSEMBLY

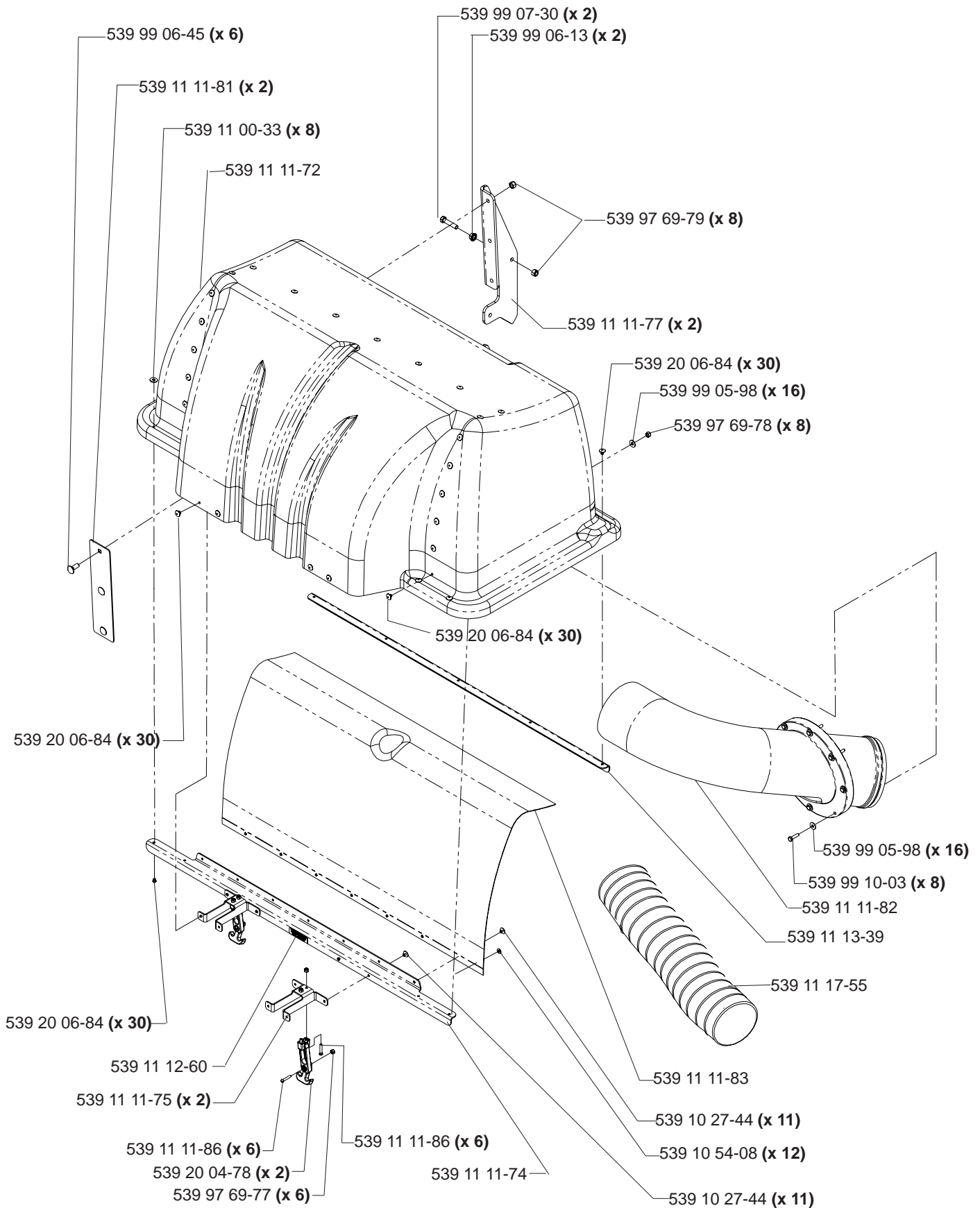

HITCH ASSEMBLY

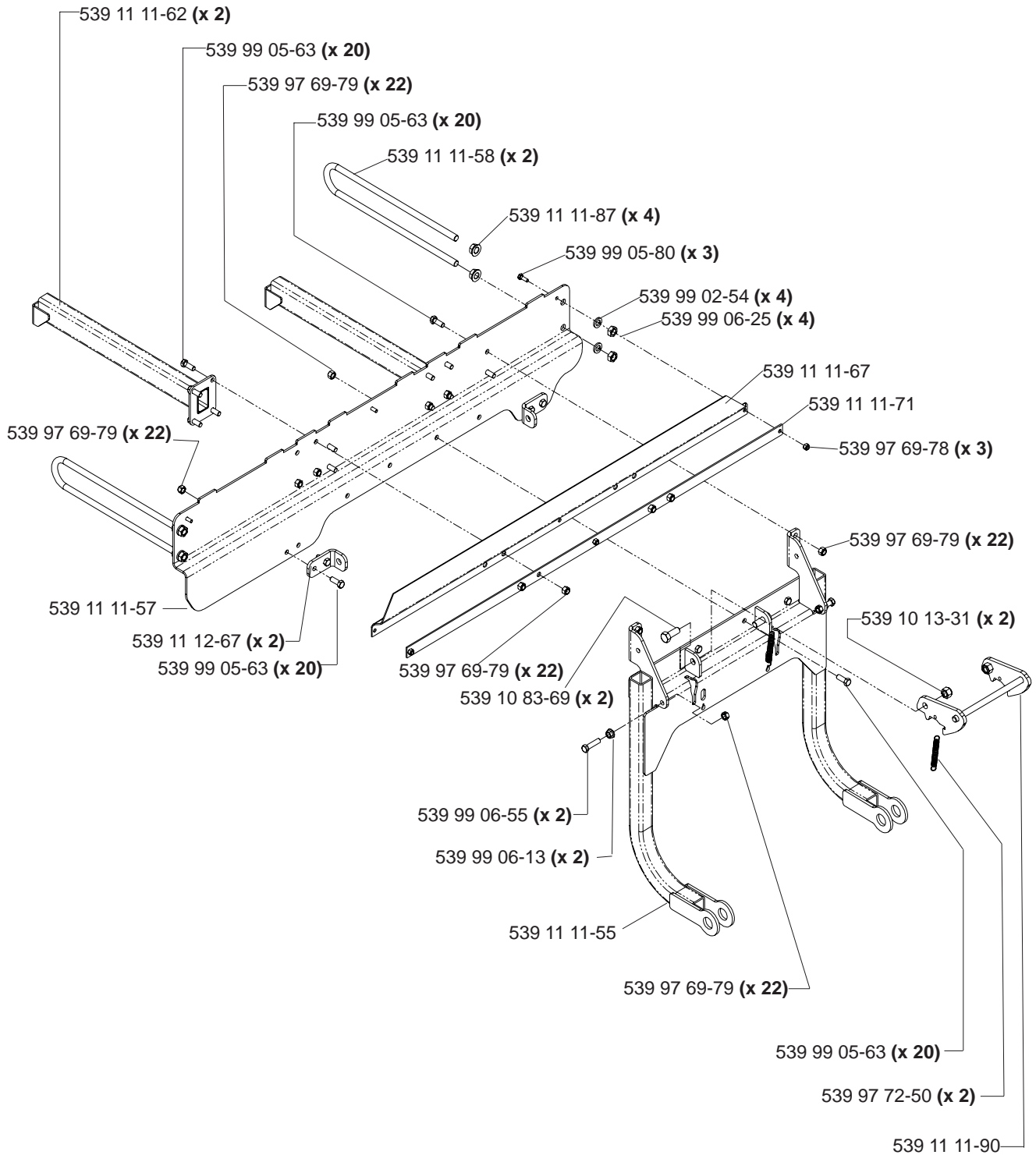

BLOWER ASSEMBLY

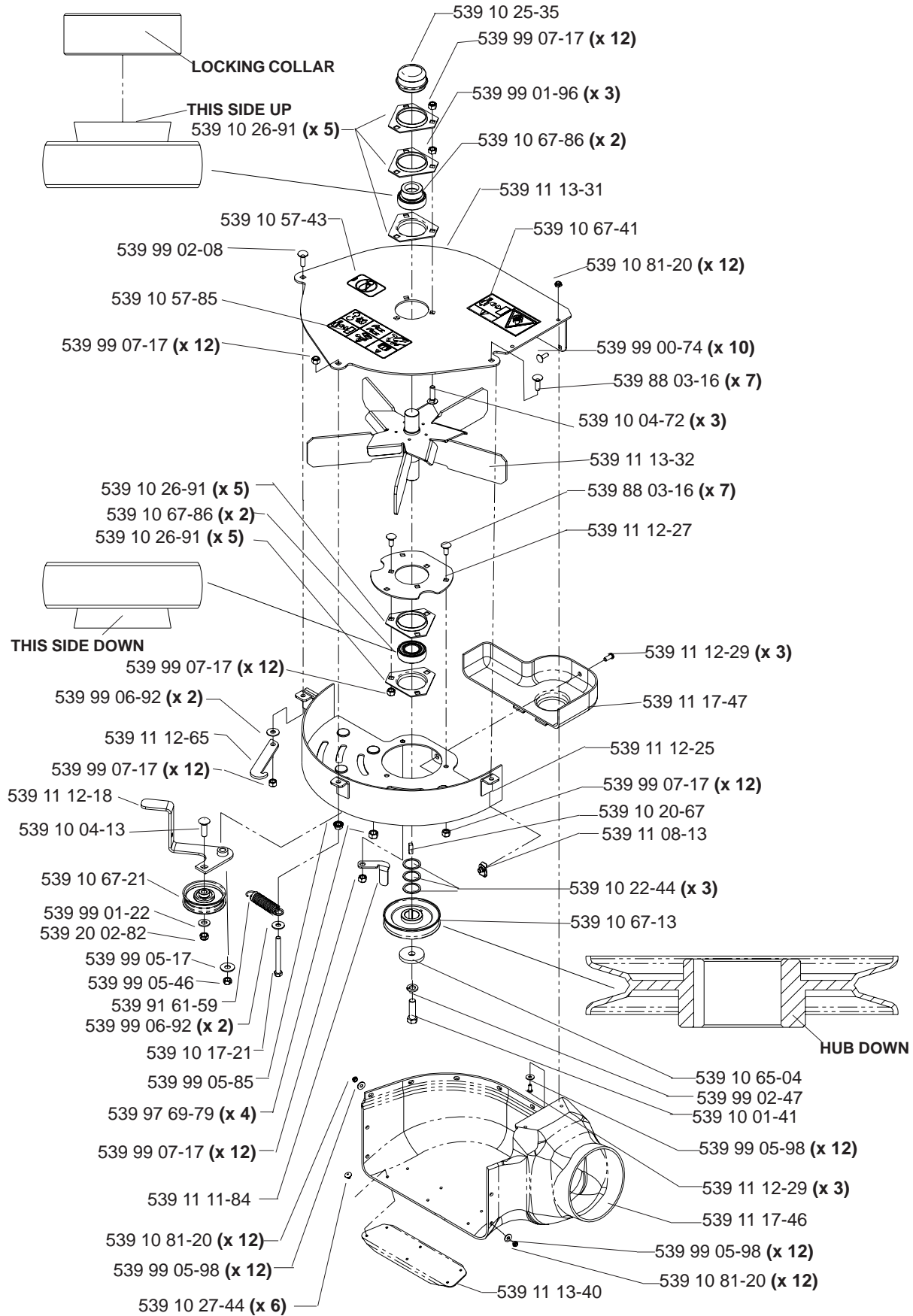

WEIGHT KIT

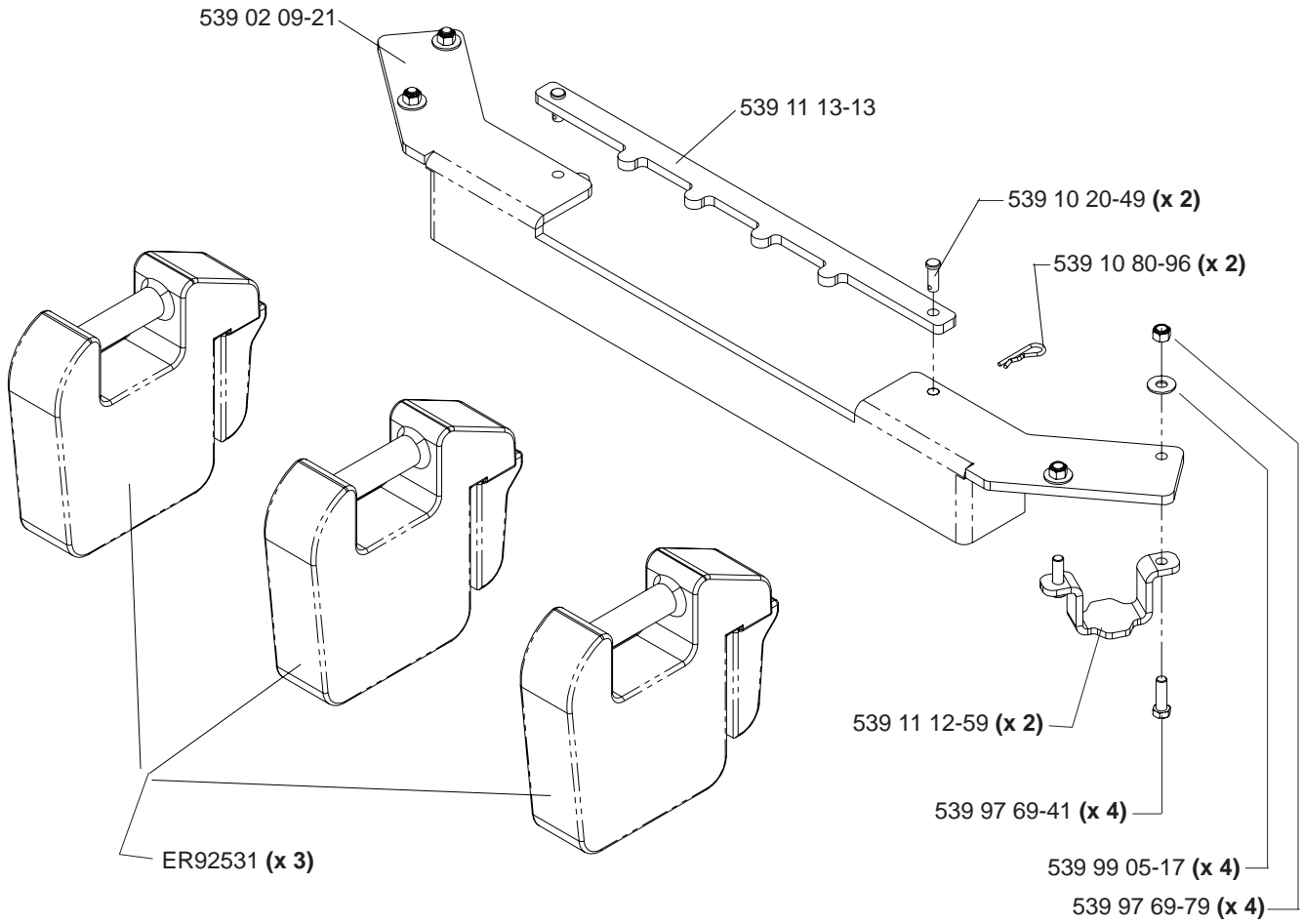

MOUNTING KIT

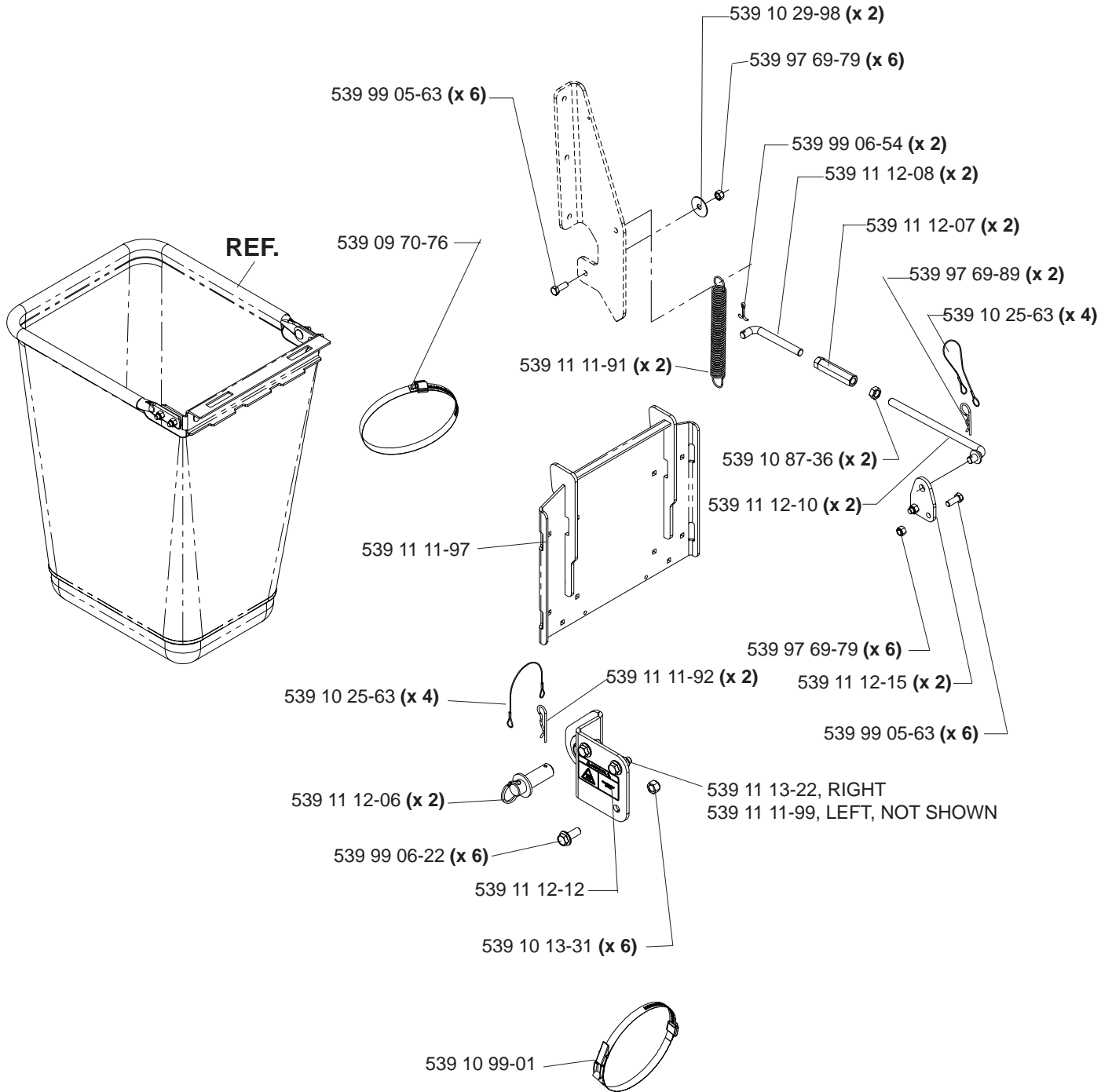

BAG ASSEMBLY

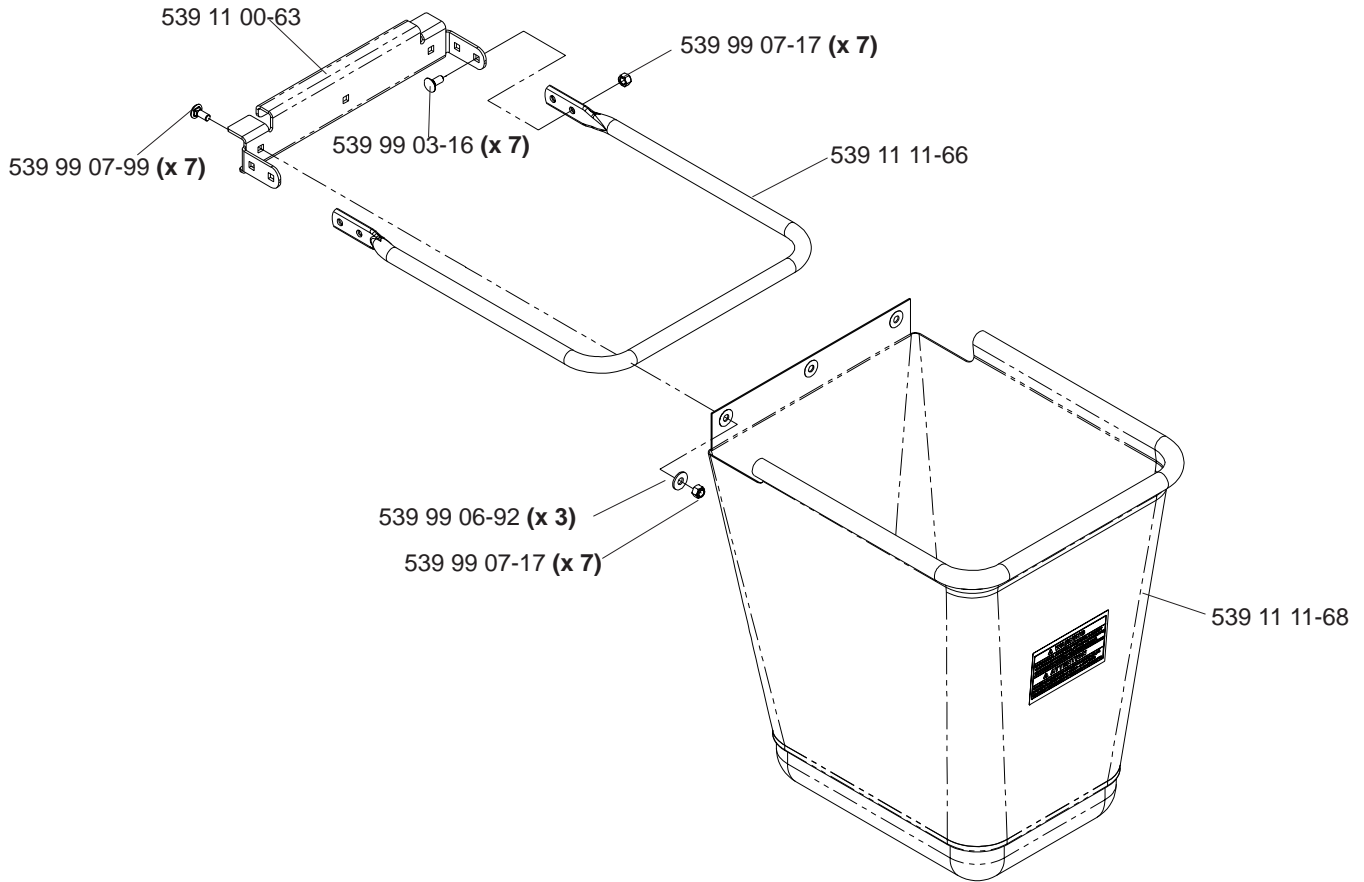

DRIVE KIT ASSEMBLY

(539) 111749 - 72 INCH DECK

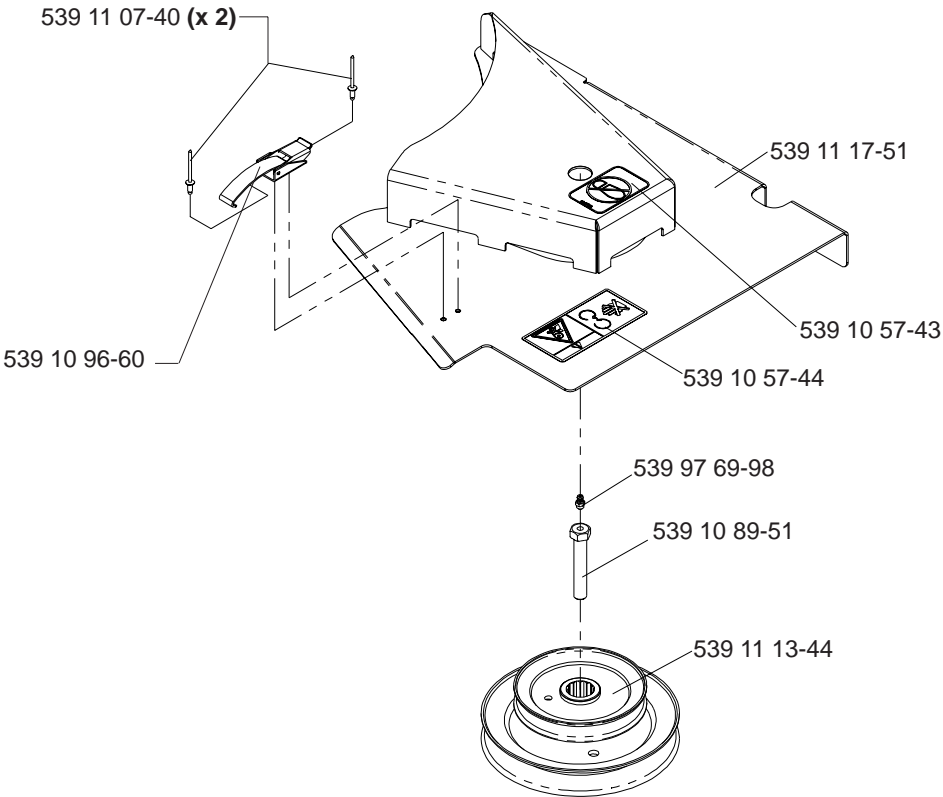

PARTS DESCRIPTION

PART NUMBER	DESCRIPTION
539 02 09-21	WEIGHT BAR, FRONT
539 09 70-76	HOSE CLAMP 6"-& 7"
539 10 01-41	HCS, 7/16-20 X 1 1/2, GR5
539 10 04-13	RHSNB, 3/8-16 X 1 1/4, GR5
539 10 04-72	RHSNB, 5/16C X 1 1/4
539 10 13-31	NUT, 1/2C, NYLOC
539 10 13-31	NUT, 1/2C, NYLOC
539 10 17-21	HCS, 5/16-18 X 2 3/4, GR5
539 10 20-49	CLEVIS PIN
539 10 20-67	KEY, 1/4" SQ. X 3/4"
539 10 22-44	BUSHING, MACHINE, 18 GA
539 10 25-35	GREASE CAP
539 10 25-63	LANYARD
539 10 25-63	LANYARD
539 10 26-91	FLANGETTE
539 10 27-44	RIVET, 3/16 X 1/4
539 10 29-98	FRICITION WASHER
539 10 54-08	WASHER, #10
539 10 57-43	DECAL, NO STEP
539 10 57-44	DECAL, DANGER BELT DRIVES
539 10 57-85	DECAL, WARNING
539 10 65-04	WASHER, HEAVY
539 10 67-13	SHEAVE, 4"
539 10 67-21	IDLER
539 10 67-41	DECAL, SERVERING
539 10 67-86	BEARING
539 10 80-96	SPRING RETAINER
539 10 81-20	NUT, 1/4C, THIN NYLOC
539 10 83-69	HCS, 1/2-13 X 1 1/4
539 10 87-36	NUT, 1/2-20, HEX JAM
539 10 89-51	HCS, 7/16-20 X 2 1/2, GR5, SPEC.
539 10 96-60	DRAW LATCH
539 10 99-01	OVER CENTER BAND
539 11 00-33	WASHER, #10
539 11 00-63	HANGER, BAG
539 11 07-40	RIVET, BLIND, DOME STYLE, 5/32 DIA.
539 11 08-13	RETAINER, 1/4C, "U" TYPE
539 11 11-55	HITCH
539 11 11-57	MOUNT Z BRACE
539 11 11-58	SUPPORT, OUTER
539 11 11-62	SUPPORT ARM
539 11 11-67	SEAL, RUBBER
539 11 11-71	SEAL STRAP
539 11 11-72	HOOD
539 11 11-74	HOOD SUPPORT
539 11 11-75	SUPPORT, DRAW LATCH
539 11 11-77	HOOD HINGE
539 11 11-81	MOUNT PLATE
539 11 11-82	INLET TUBE
539 11 11-83	MESH, POLY DIAMOND
539 11 11-84	BELT GUIDE
539 11 11-86	SCREW, #10-24 X 1 1/8, MACH.

PARTS DESCRIPTION

PART NUMBER	DESCRIPTION
539 11 11-87	NUT, 1/2-13, WHIZLOCK
539 11 11-90	LATCH
539 11 11-91	SPRING
539 11 11-92	HAIRPIN
539 11 11-97	REAR GUARD
539 11 11-99	HITCH BRACKET, LEFT (NOT SHOWN)
539 11 12-06	HITCH PIN
539 11 12-07	TURNBUCKLE, 1/2"
539 11 12-08	SUPPORT LINKAGE, LH
539 11 12-10	SUPPORT LINKAGE
539 11 12-12	DECAL, HOT SURFACE
539 11 12-15	SUPPORT BRACKET
539 11 12-18	IDLER ARM
539 11 12-25	FLOOR WELDMENT
539 11 12-27	BEARING PLATE
539 11 12-29	SCREW, 1/4-20 X 5/8, BTN, SKT HD
539 11 12-59	WEIGHT KEEPER
539 11 12-60	DECAL, VENTILATION
539 11 12-65	KEEPER, IDLER
539 11 12-67	BRACKET, SUPPORT
539 11 12-70	PIN
539 11 13-13	HOLD DOWN, WEIGHT BAR
539 11 13-22	HITCH BRACKET, RIGHT, W/DECAL
539 11 13-28	BLOWER DECK PLATE
539 11 13-31	FAN COVER
539 11 13-32	FAN WELDMENT
539 11 13-39	HOOD SUPPORT, REAR
539 11 13-40	BLOWER SUPPORT
539 11 13-44	PULLEY, STACKED DOUBLE
539 11 17-46	BLOWER HOUSING
539 11 17-47	PULLEY SHIELD
539 11 17-51	BELT SHIELD W/DECALS & LATCH
539 11 17-52	BELT
539 11 17-55	HOSE
539 20 02-82	NUT, 3/8-16, JAM NYLOC
539 20 04-78	DRAW LATCH, FLEXIBLE T-HANDLE
539 20 06-84	RIVET, 1/4 STAVEX
539 88 03-16	RHSNB, 5/16 X 3/4
539 91 61-59	SPRING
539 97 69-41	HCS, 3/8-16 X 1 1/4, GR5
539 97 69-77	NUT, #10-24, NYLOC
539 97 69-78	NUT, 1/4C, NYLOC
539 97 69-79	NUT, 3/8C, NYLOC
539 97 69-89	HAIRPIN #4
539 97 69-98	ZERK
539 97 72-50	SPRING
539 99 00-74	RHSNB, 1/4-20 X 3/4, GR2
539 99 01-22	WASHER, 3/8, SAE
539 99 01-96	NUT, 5/16C
539 99 02-08	RHSNB, 5/16-18 X 1, GR5

PARTS DESCRIPTION

PART NUMBER	DESCRIPTION
539 99 02-47	LOCKWASHER, 7/16
539 99 02-54	WASHER, 1/2
539 99 03-16	RHSNB 5/16-18 X 5/8, GR5
539 99 05-17	WASHER, 3/8
539 99 05-46	NUT, 3/8, CENTERLOCK
539 99 05-63	HCS, 3/8-16 x 1, GR5
539 99 05-80	HCS, 1/4-20 X 3/4
539 99 05-85	NUT, 5/16C
539 99 05-98	WASHER, 1/4
539 99 06-13	NUT, 3/8C
539 99 06-22	HFS, 1/2-13 X 1 1/2
539 99 06-25	NUT, 1/2, JAM
539 99 06-45	RHSNB, 3/8-16 X 1
539 99 06-54	COTTER PIN, 5/32 X 1 1/4
539 99 06-55	HCS, 3/8-16 X 1 1/2
539 99 06-92	WASHER, 5/16
539 99 07-17	NUT, 5/16C, NYLOC
539 99 07-30	HCS, 3/8-16 X 1 3/4
539 99 10-03	HCS, 1/4-20 X 1 3/4
ER92531	CAST COUNTERWEIGHT

 **Husqvarna**