



SPARE PARTS LIST

HEDGE TRIMMERS/POLE HEDGE
TRIMMERS

325 HS99 X-SERIES, 2006-09

N Accessories
Zubehöre
Accessoires
Acessorios
Tillbehör
*compl 502 21 60-09

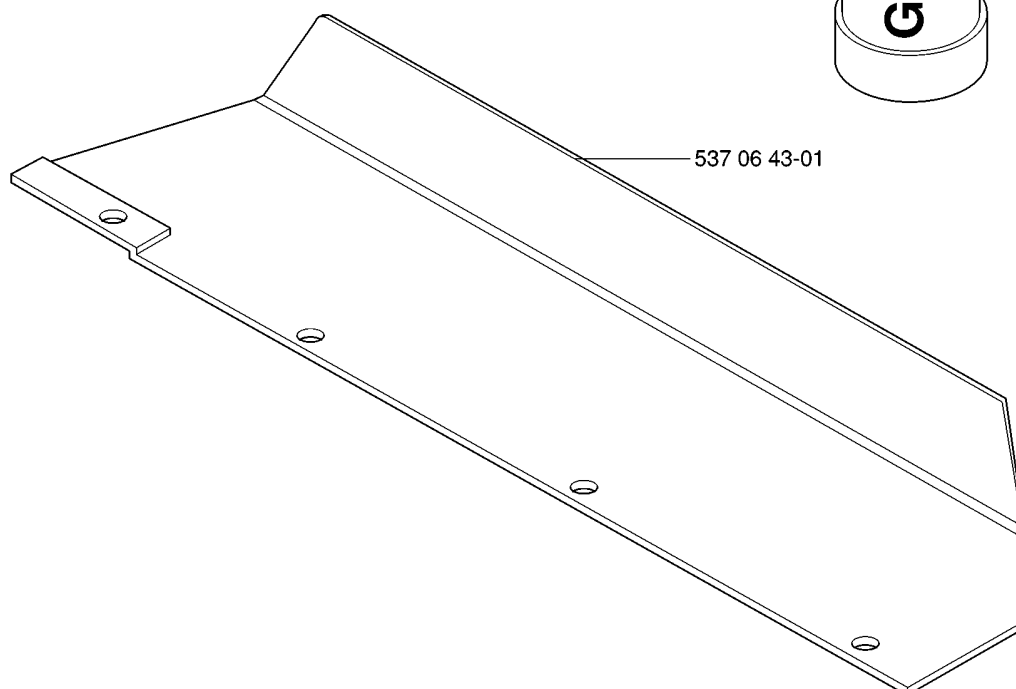
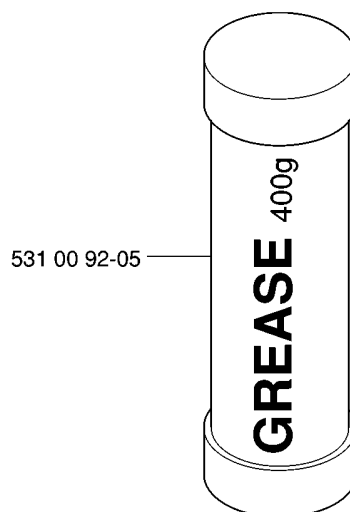
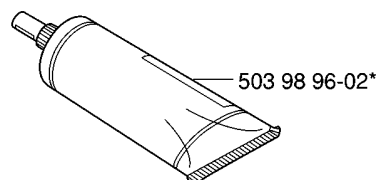
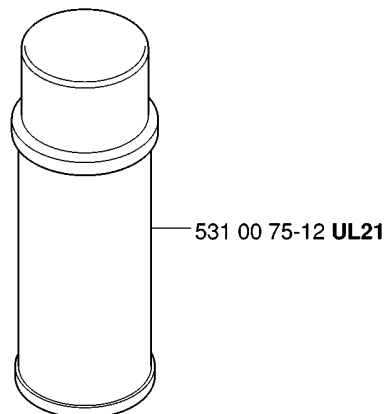
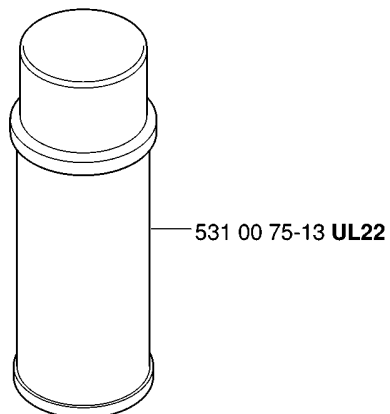
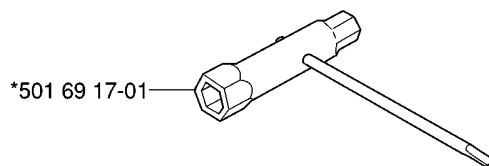
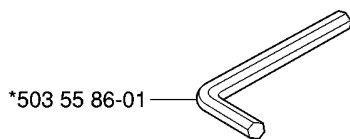

ACCESSORIES

325 HS99 X-SERIES, 2006-09

Part No	Description	Remark	QTY KIT
501 69 17-01	COMBINATION WRENCH		1
502 21 60-09	ACCESSORY BAG		1
503 55 86-01	SPANNER		1
503 98 96-02	GREASE		1
531 00 75-12	GREASE		1
531 00 75-13	GREASE		1
531 00 92-05	GREASE		1
537 06 43-01	PLATE		1

M compl 503 28 34-03

ZAMA C1Q - EL 26A

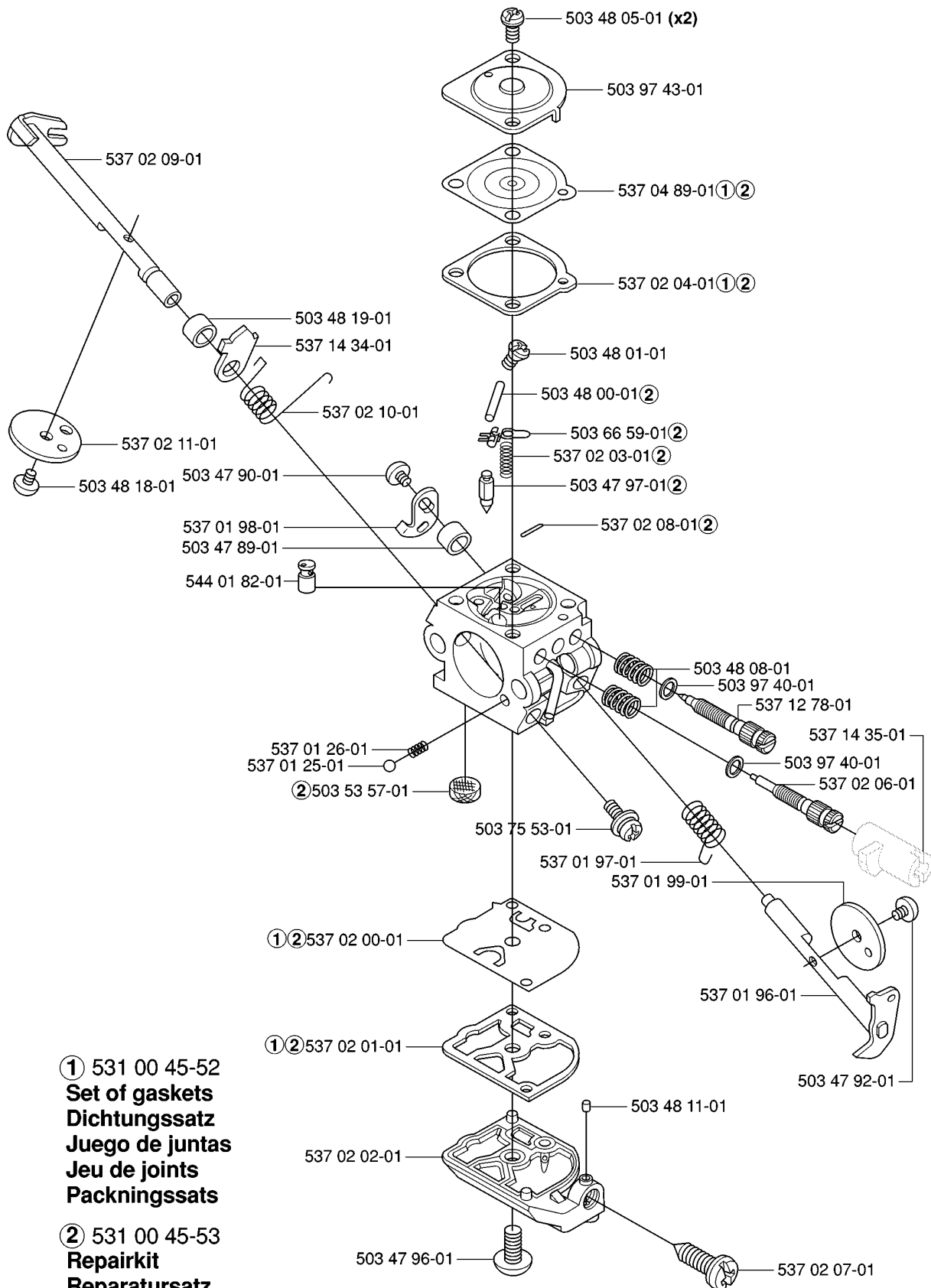

(1) 531 00 45-52
Set of gaskets
Dichtungssatz
Juego de juntas
Jeu de joints
Packningssatz

(2) 531 00 45-53
Repairkit
Reparaturatz
Juego de reparación
Kit de réparation
Reparationsatz

CARBURETOR

325 HS99 X-SERIES, 2006-09

Part No	Description	Remark	QTY KIT
503 28 34-03	CARBURETTOR		1
503 47 89-01	COLLAR		1
503 47 90-01	SCREW		1
503 47 92-01	SCREW		1
503 47 96-01	SCREW		1
503 47 97-01	VALVE		1
503 48 00-01	PIN RETAINING SCREW		1
503 48 01-01	SCREW		1
503 48 05-01	SCREW		2
503 48 08-01	SPRING		1
503 48 11-01	PIECE		1
503 48 18-01	SCREW		1
503 48 19-01	COLLAR		1
503 53 57-01	STRAINER		1
503 66 59-01	LEVER		1
503 75 53-01	SCREW		1
503 97 40-01	WASHER		1
503 97 40-01	WASHER		1
503 97 43-01	COVER		1
537 01 25-01	BALL		1
537 01 26-01	SPRING		1
537 01 96-01	SHAFT ASSY		1
537 01 97-01	SPRING		1
537 01 98-01	LEVER		1
537 01 99-01	VALVE		1
537 02 00-01	DIAPHRAGM PUMP		1
537 02 01-01	GASKET		1
537 02 02-01	COVER		1
537 02 03-01	SPRING		1
537 02 04-01	GASKET		1
537 02 06-01	SCREW		1
537 02 07-01	SCREW		1
537 02 08-01	PLUG		1
537 02 09-01	SHAFT ASSY		1
537 02 10-01	SPRING		1
537 02 11-01	VALVE		1
537 04 89-01	DIAPHRAGM		1
537 12 78-01	SCREW		1
537 14 34-01	LEVER		1
537 14 35-01	RETAINER		1
544 01 82-01	MAIN NOZZLE		1

G

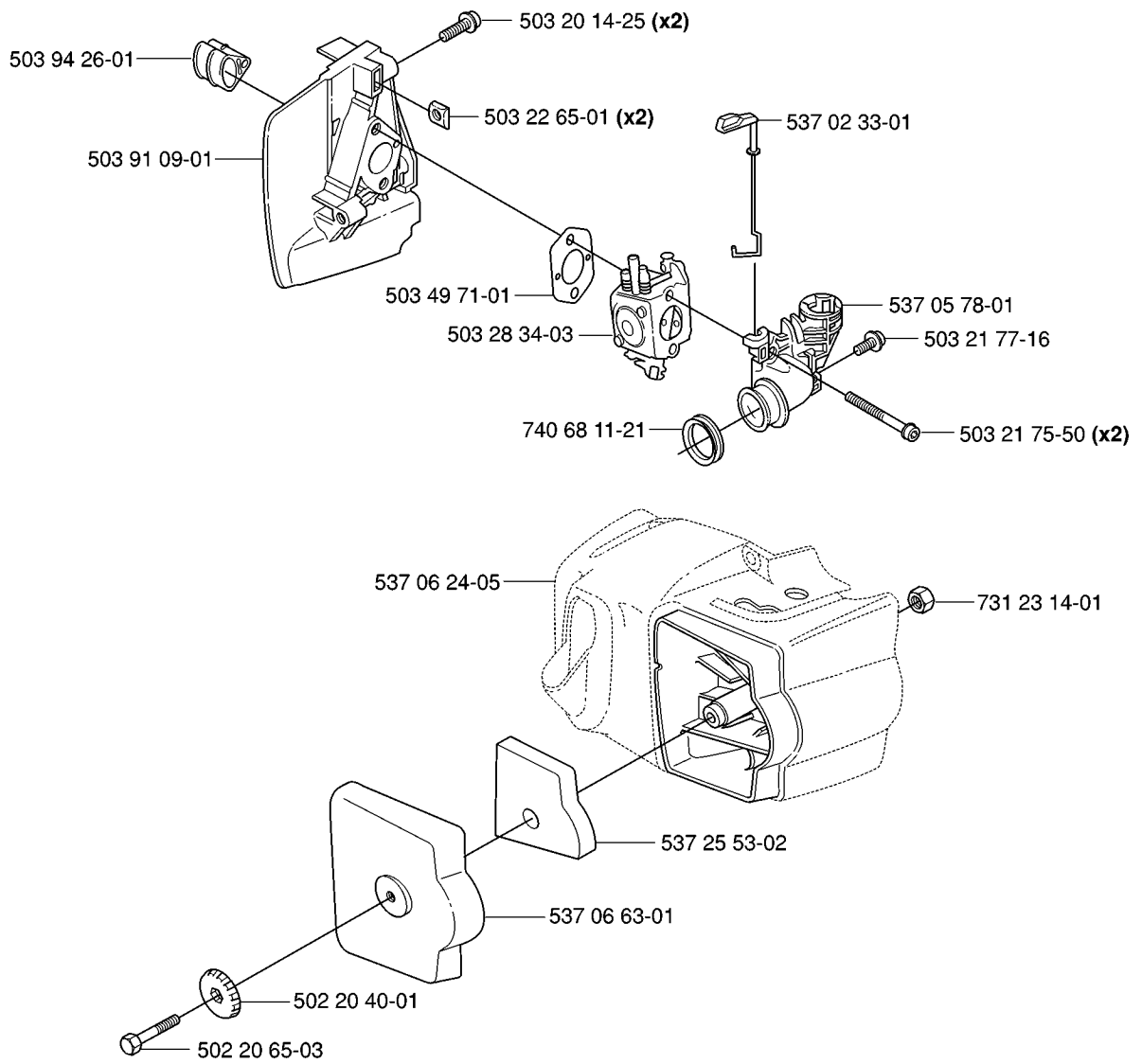

CARBURETOR & AIR FILTER

325 HS99 X-SERIES, 2006-09

Part No	Description	Remark	QTY KIT
502 20 40-01	KNOB		1
502 20 65-03	SCREW EHHM		1
503 20 14-25	SCREW IHSCFMO		2
503 21 75-50	SCREW IHSCFT		2
503 21 77-16	SCREW IHSCFT		1
503 22 65-01	SQUARE NUT		2
503 28 34-03	CARBURETTOR		1
503 49 71-01	GASKET		1
503 91 09-01	INSULATION WALL		1
503 94 26-01	INLET PIPE		1
537 02 33-01	CHOKE CONTROL		1
537 05 78-01	BRACKET		1
537 06 24-05	CYLINDER COVER		1
537 06 63-01	FILTER COVER		1
537 25 53-01	AIR FILTER		1
731 23 14-01	HEXAGON NUT		1
740 68 11-21	V-RING		1

F

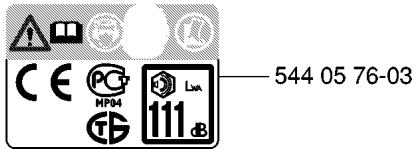
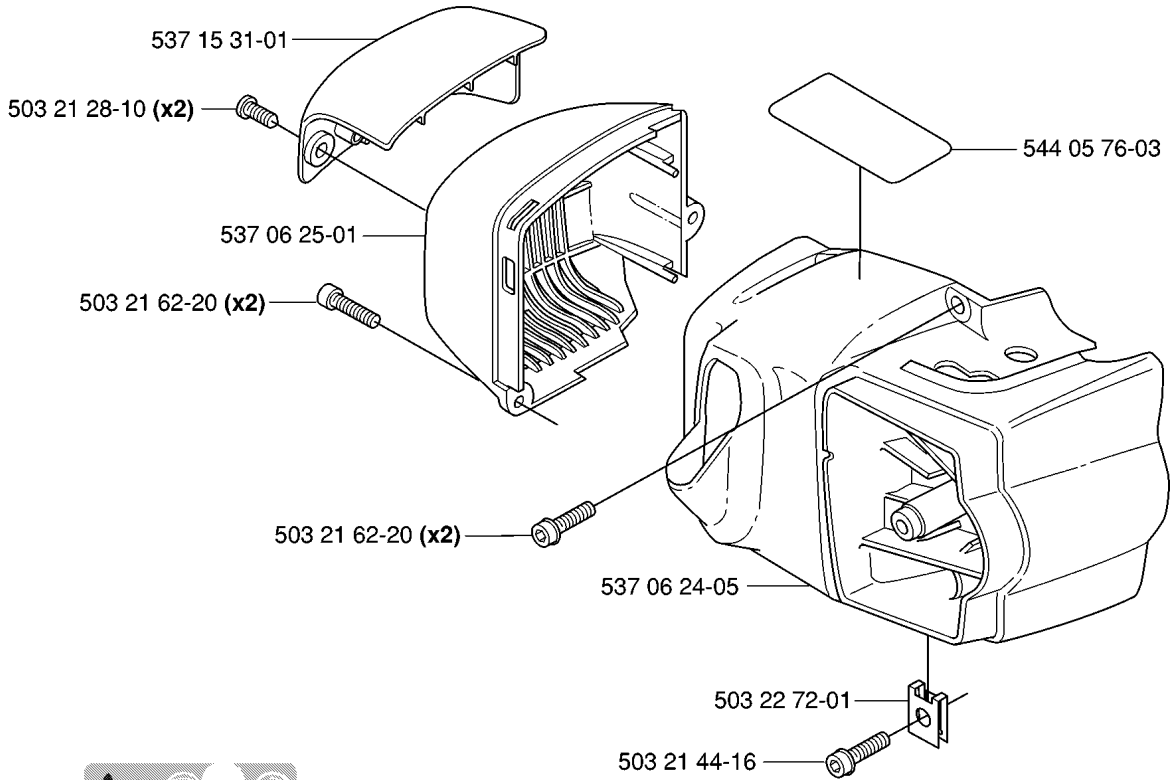

COVER

325 HS99 X-SERIES, 2006-09

Part No	Description	Remark	QTY KIT
503 21 28-10	SCREW CCRPANT		2
503 21 44-16	SCREW IHSCFTO		1
503 21 62-20	SCREW IHSCFT		2
503 21 62-20	SCREW IHSCFT		2
503 22 72-01	SPEED NUT		1
537 06 24-05	CYLINDER COVER		1
537 06 25-01	HEAT PROTECTOR		1
537 15 31-01	HEAT SHIELD		1
544 05 76-03	LABEL		1
544 05 76-03	LABEL		1

E *compl 537 04 11-02

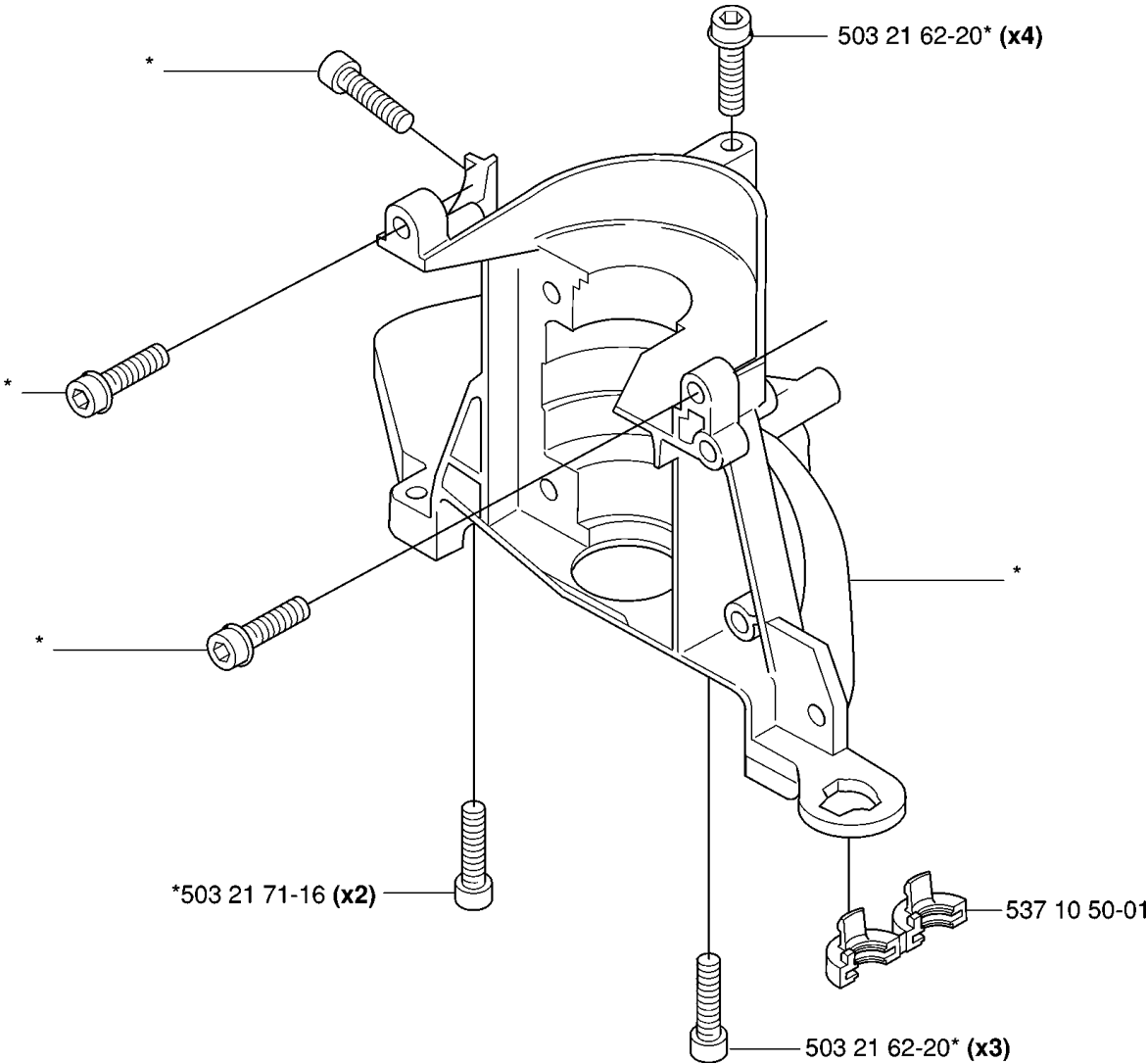

CRANKCASE

325 HS99 X-SERIES, 2006-09

Part No	Description	Remark	QTY KIT
503 21 62-20	SCREW IHSCFT		3
503 21 62-20	SCREW IHSCFT		4
503 21 71-16	SCREW IHSCFT		2
537 04 11-02	CRANKCASE		1
537 10 50-01	SNAP		1

A *compl 537 12 81-77

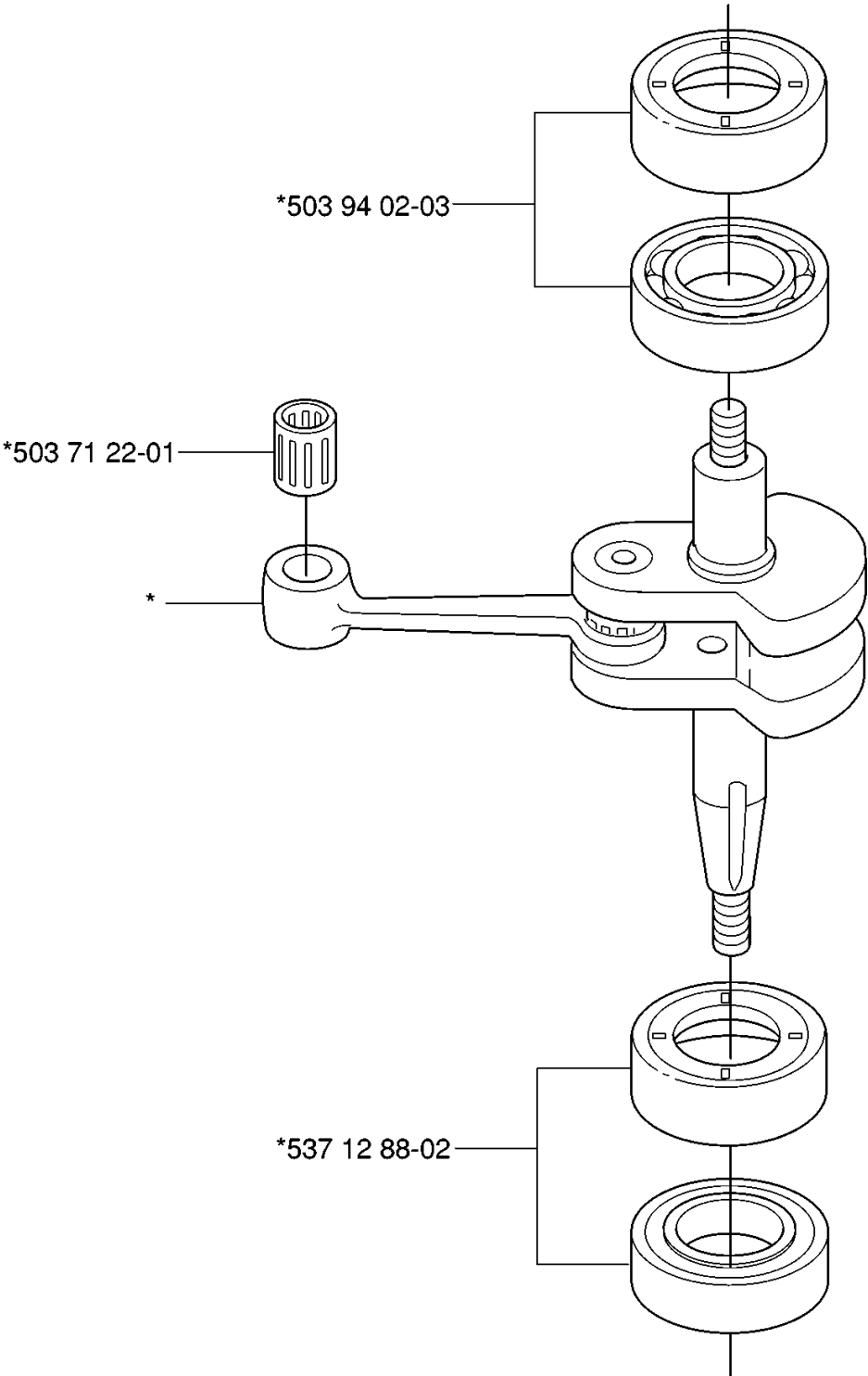

CRANKSHAFT

325 HS99 X-SERIES, 2006-09

Part No	Description	Remark	QTY KIT
503 71 22-01	BEARING		1
503 94 02-03	BEARING CAGE		1
537 12 81-77	CRANKSHAFT ASSY		1
537 12 88-02	BEARING CAGE		1

J *compl 537 03 77-07 (Type A) 325HS75
 *compl 537 03 77-08 325HS99

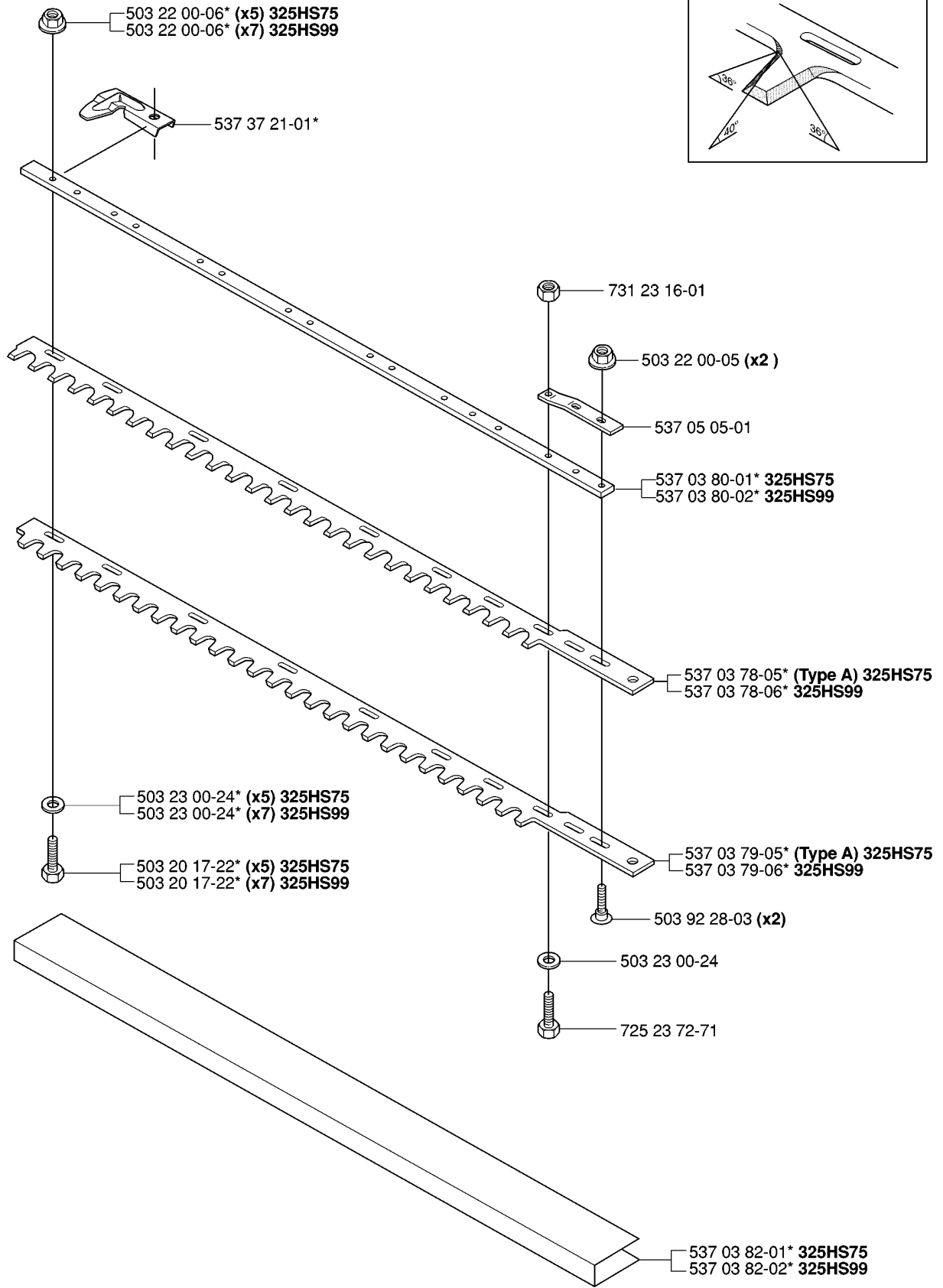
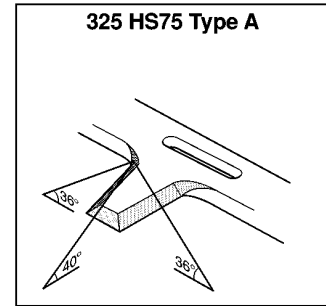

CUTTING EQUIPMENT

325 HS99 X-SERIES, 2006-09

Part No	Description	Remark	QTY KIT
503 20 17-22	SCREW EHHM		5
503 20 17-22	SCREW EHHM		7
503 22 00-05	HEXAGON NUT		2
503 22 00-06	HEXAGON NUT		5
503 22 00-06	HEXAGON NUT		7
503 23 00-24	WASHER		5
503 23 00-24	WASHER		7
503 23 00-24	WASHER		1
503 92 28-03	SCREW		2
537 03 77-07	CUTTING DECK		1
537 03 77-08	CUTTING DECK		1
537 03 78-05	BLADE		1
537 03 78-06	BLADE		1
537 03 79-05	BLADE		1
537 03 79-06	BLADE		1
537 03 80-01	BEAM		1
537 03 80-02	BEAM		1
537 03 82-01	TRANSPORT GUARD		1
537 03 82-02	TRANSPORT GUARD		1
537 05 05-01	BASEPLATE		1
537 37 21-01	COVER		1
725 23 72-71	SCREW EHHM		1
731 23 16-01	HEXAGON NUT		1

C

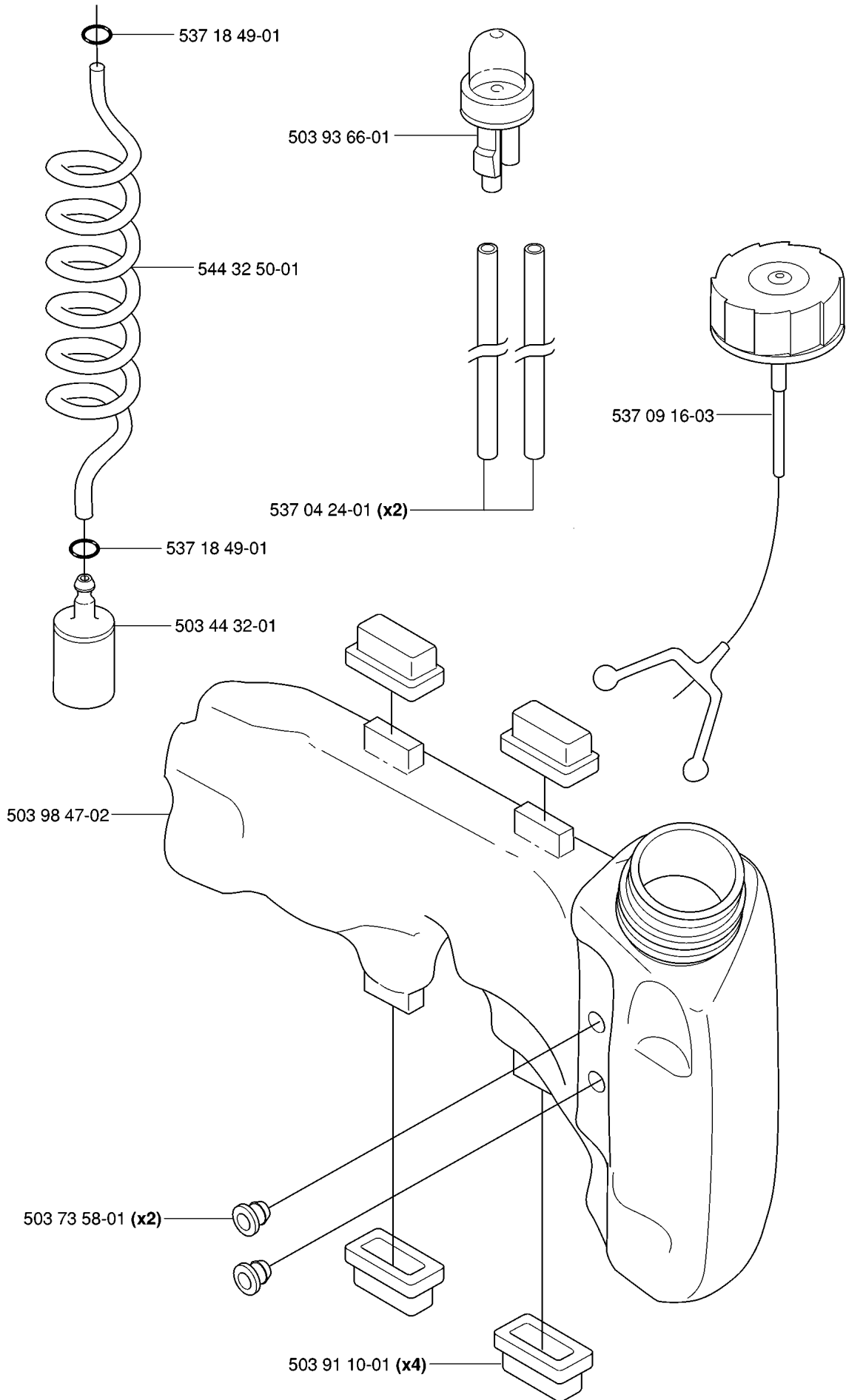

FUEL TANK

325 HS99 X-SERIES, 2006-09

Part No	Description	Remark	QTY KIT
503 44 32-01	FILTER		1
503 73 58-01	BUSHING		2
503 91 10-01	SUSPENSION		4
503 93 66-01	PRIMER HOUSING		1
503 98 47-02	FUEL TANK		1
537 04 24-01	FUEL HOSE		2
537 09 16-03	TANK CAP		1
537 18 49-01	O-RING		1
537 18 49-01	O-RING		1
544 32 50-01	FUEL HOSE		1

K

*compl 537 06 74-73

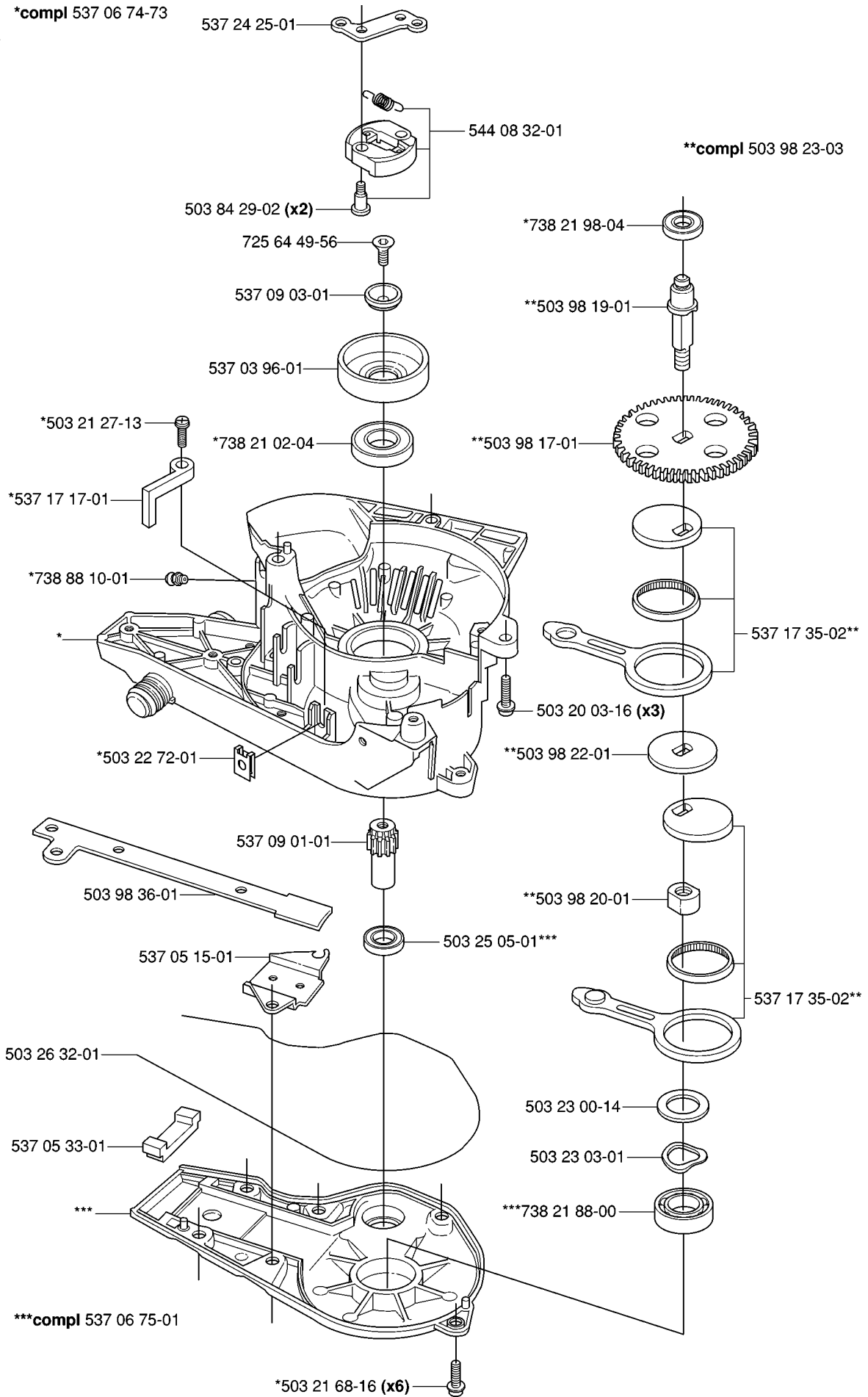

GEAR HOUSING

325 HS99 X-SERIES, 2006-09

Part No	Description	Remark	QTY KIT
503 20 03-16	SCREW IHSCFM		3
503 21 27-13	SCREW CCRPANT		1
503 21 68-16	SCREW IHSCF		6
503 22 72-01	SPEED NUT		1
503 23 00-14	WASHER		1
503 23 03-01	WASHER		1
503 25 05-01	BALL BEARING		1
503 26 32-01	O-RING		1
503 84 29-02	SCREW		2
503 98 17-01	GEAR RIM		1
503 98 19-01	DRIVE SHAFT		1
503 98 20-01	NUT		1
503 98 22-01	SPACER		1
503 98 23-03	DRIVE SHAFT		1
503 98 36-01	WEAR PLATE		1
537 03 96-01	CLUTCH DRUM		1
537 05 15-01	GUIDE PLATE		1
537 05 33-01	SEALING		1
537 06 74-73	GEAR HOUSING		1
537 06 75-01	HUB CAP		1
537 09 01-01	GEAR WHEEL SHAFT		1
537 09 03-01	WASHER		1
537 17 17-01	BRACKET		1
537 17 35-02	CONNECTING ROD		1
537 17 35-02	CONNECTING ROD		1
537 24 25-01	CLUTCH HUB		1
544 08 32-01	CLUTCH ASSY		1
725 64 49-56	SCREW IHCSFM		1
738 21 02-04	BALL BEARING		1
738 21 88-00	BALL BEARING		1
738 21 98-04	BALL BEARING		1
738 88 10-01	LUBRICATION NIPPLE		1

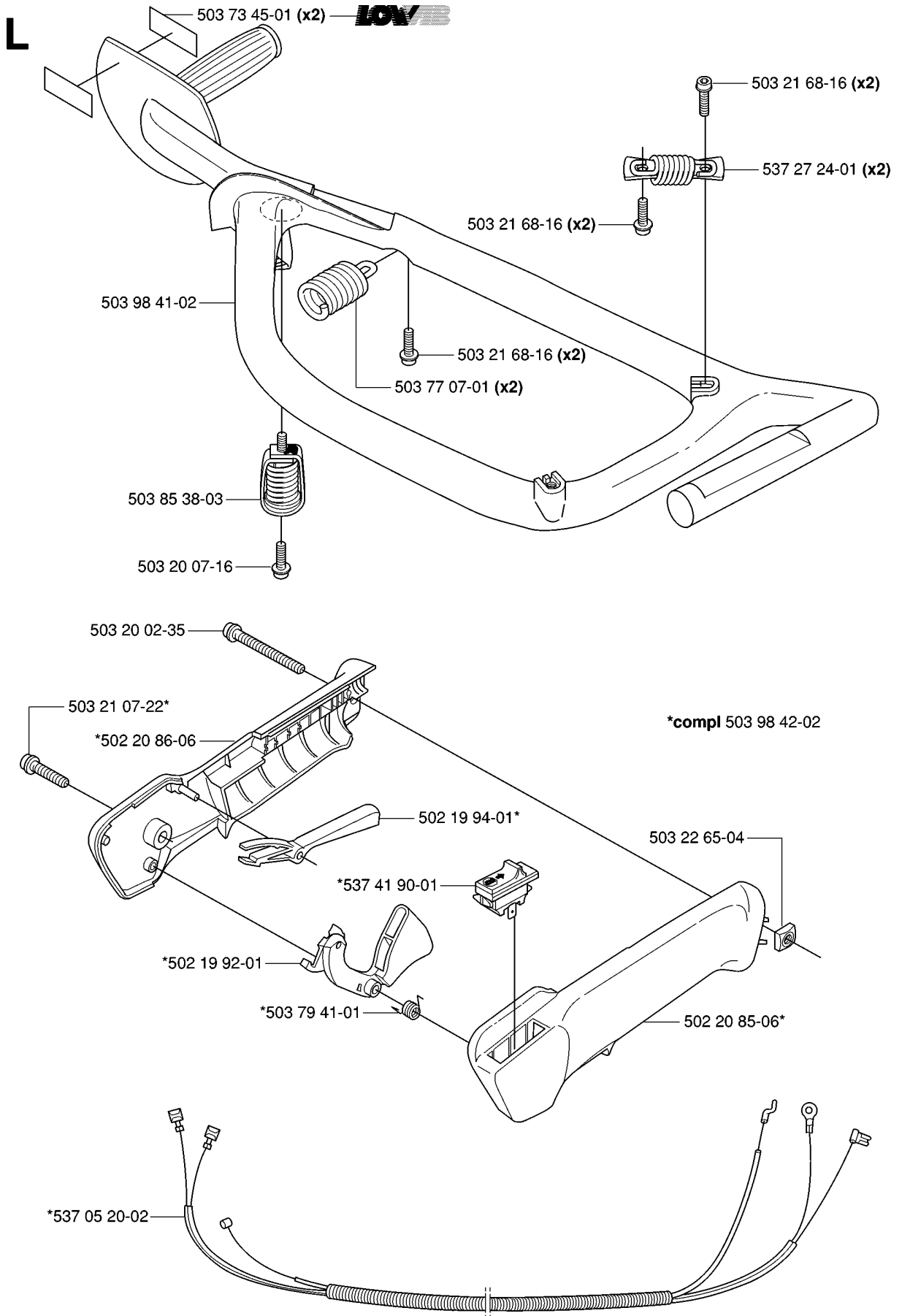

HANDLE & CONTROLS

325 HS99 X-SERIES, 2006-09

Part No	Description	Remark	QTY KIT
502 19 92-01	THROTTLE TRIGGER		1
502 19 94-01	THROTTLE LOCKOUT		1
502 20 85-06	HANDLE HALF		1
502 20 86-06	HANDLE HALF		1
503 20 02-35	SCREW IHSCFM		1
503 20 07-16	SCREW IHSCFM		1
503 21 07-22	SCREW IHCT		1
503 21 68-16	SCREW IHCT		2
503 21 68-16	SCREW IHCT		2
503 21 68-16	SCREW IHCT		2
503 22 65-04	SQUARE NUT		1
503 73 45-01	LABEL		2
503 77 07-01	ANTIVIBRATION ELEMENT		2
503 79 41-01	RECOIL SPRING		1
503 85 38-03	ANTIVIBRATION ELEMENT		1
503 98 41-02	FRAME		1
503 98 42-02	HANDLE		1
537 05 20-02	WIRING ASSY		1
537 27 24-01	ANTIVIBRATION ELEMENT		2
537 41 90-01	SWITCH		1

B *compl 537 41 88-01

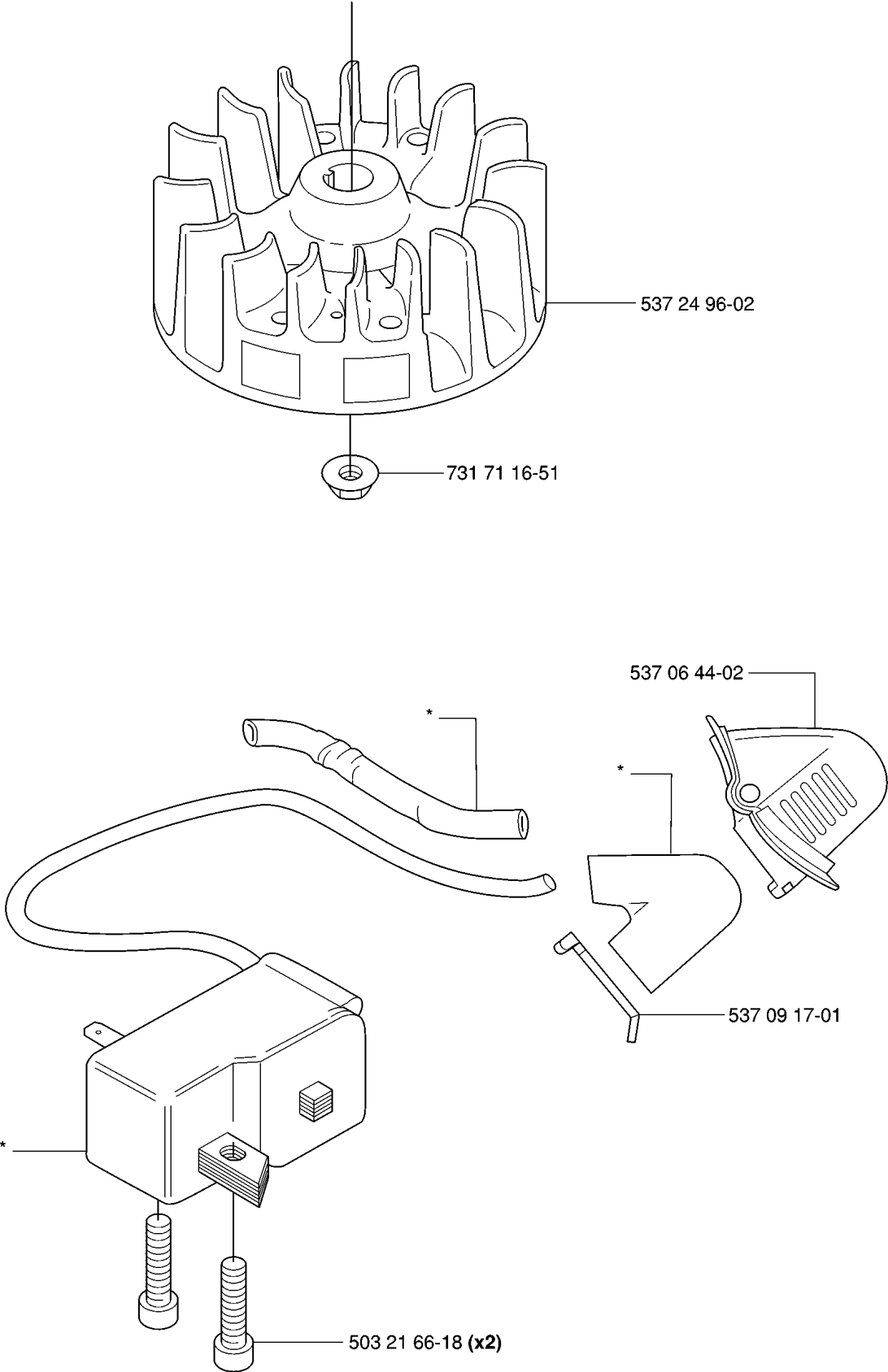

IGNITION SYSTEM

325 HS99 X-SERIES, 2006-09

Part No	Description	Remark	QTY KIT
503 21 66-18	SCREW IH SCT		2
537 06 44-02	COVER		1
537 09 17-01	SECURING PLATE		1
537 24 96-02	FLYWHEEL		1
537 41 88-01	ELECTRONIC MODULE		1
731 71 16-51	HEXAGON NUT FLANGE		1

D *compl 537 04 57-01

**compl 537 03 20-08

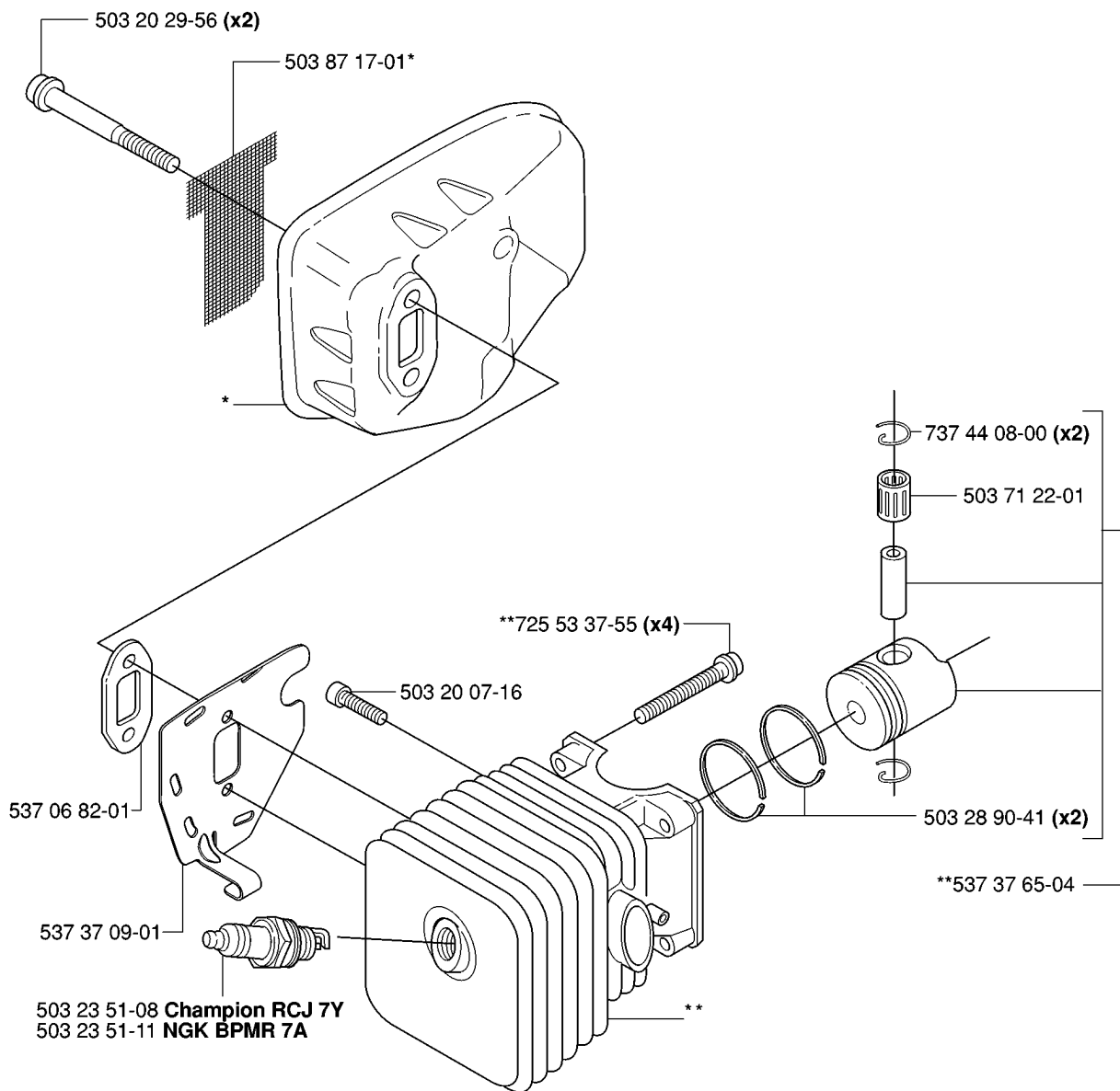

MUFFLER

325 HS99 X-SERIES, 2006-09

Part No	Description	Remark	QTY KIT
503 20 07-16	SCREW IHSCFM		1
503 20 29-56	SCREW IHSCFM		2
503 23 51-08	SPARK PLUG		1
503 23 51-11	SPARK PLUG		1
503 28 90-41	PISTON RING		2
503 71 22-01	BEARING		1
503 87 17-01	SPARK ARRESTER SCREEN		1
537 03 20-08	CYLINDER		1
537 04 57-01	MUFFLER ASSY		1
537 06 82-01	SPACER		1
537 37 09-01	AIR CONDUCTOR		1
537 37 65-04	PISTON		1
725 53 37-55	SCREW IHSCM		4
737 44 08-00	CIRCLIP		2

H *compl 544 00 25-02

****compl 503 87 33-03**

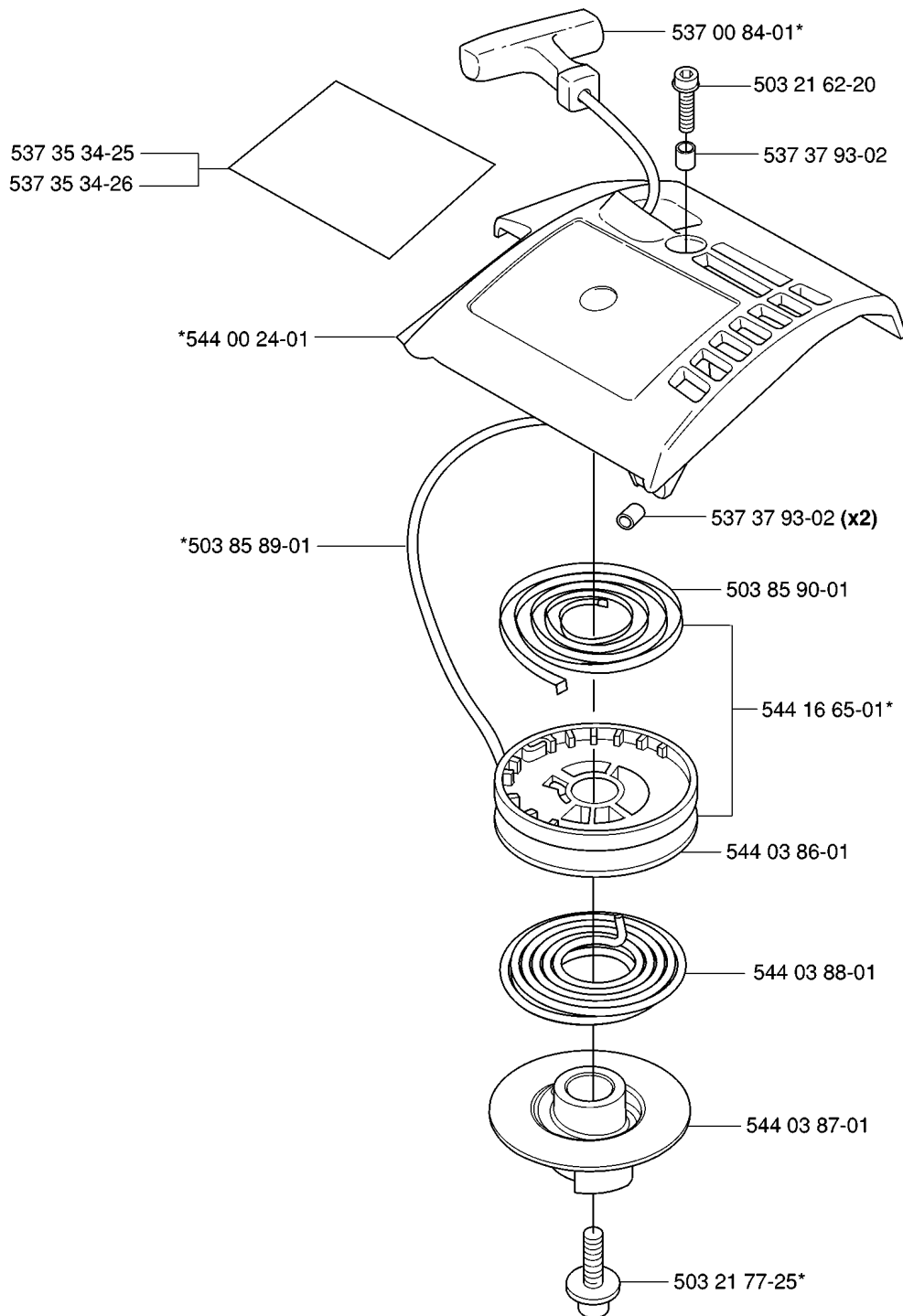
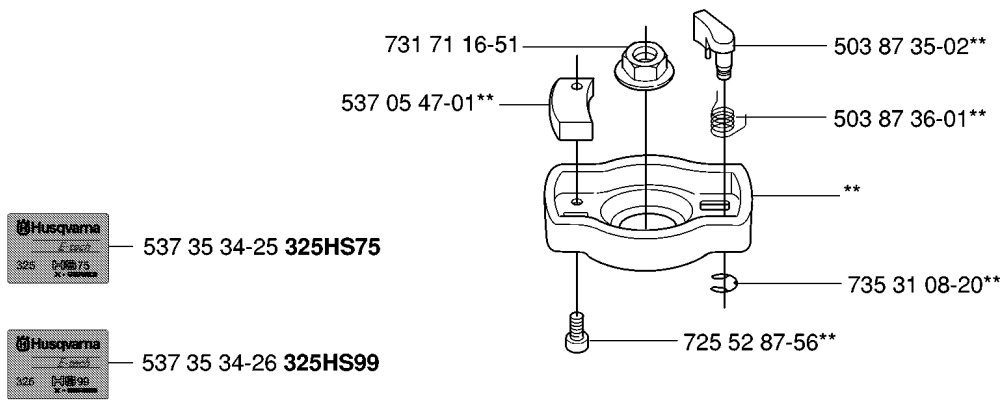

STARTER

325 HS99 X-SERIES, 2006-09

Part No	Description	Remark	QTY KIT
503 21 62-20	SCREW IHSCFT		1
503 21 77-25	SCREW IHSCFT		1
503 85 89-01	STARTER CORD		1
503 85 90-01	RECOIL SPRING		1
503 87 33-03	BRIDGE		1
503 87 35-02	STARTER PAWL		1
503 87 36-01	SPRING		1
537 00 84-01	STARTER HANDLE		1
537 05 47-01	COUNTERWEIGHT		1
537 35 34-25	LABEL		1
537 35 34-25	LABEL		1
537 35 34-26	LABEL		1
537 35 34-26	LABEL		1
537 37 93-02	SPACING SLEEVE		2
537 37 93-02	SPACING SLEEVE		1
544 00 24-01	STARTER HOUSING		1
544 00 25-02	STARTER ASSY		1
544 03 86-01	STARTER PULLEY		1
544 03 87-01	DRIVER		1
544 03 88-01	SPRING		1
544 16 65-01	STARTER PULLEY ASSY		1
725 52 87-56	SCREW IHSCM		1
731 71 16-51	HEXAGON NUT FLANGE		1
735 31 08-20	E-CLIP		1