

# LT151

**Spare parts**  
**Ersatzteile**  
**Pièces détachées**  
**Reserve onderdelen**  
**Repuestos**  
**Reservdelar**

# ILLUSTRATED PARTS LIST

**MODEL NO. 96011011000**  
**CUSTOMER CATALOG NO. LT151**  
**PRODUCT NO. 960 11 01-10**

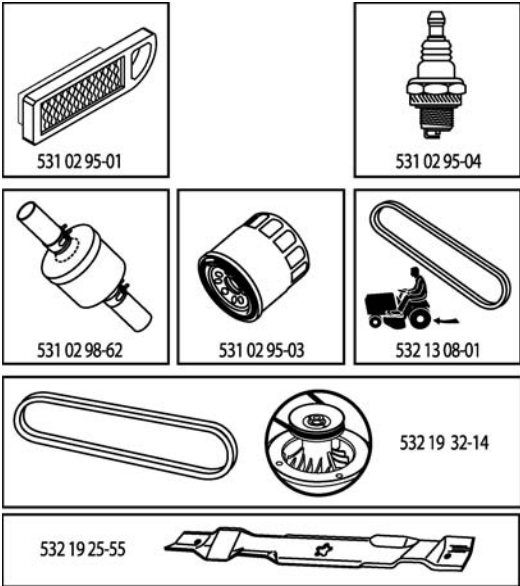

400418

# TRACTOR - MODEL NO. LT151 (96011011000), PRODUCT NO. 960 11 01-10 SCHEMATIC

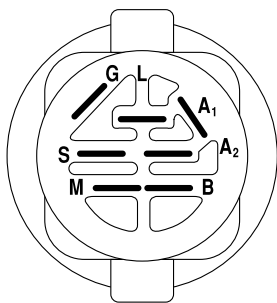
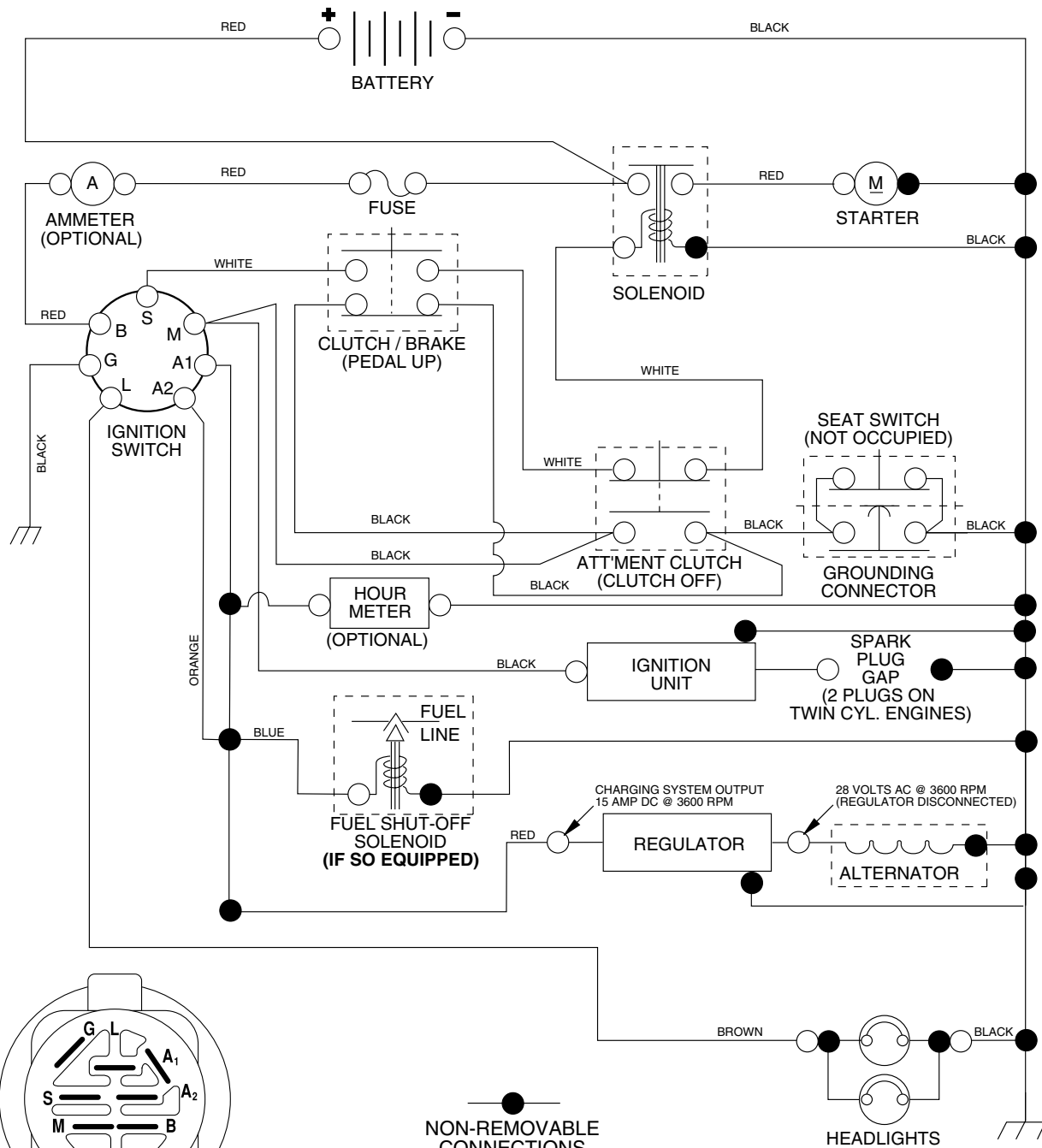

**IGNITION SWITCH**

POSITION	CIRCUIT	"MAKE"
OFF	M+G+A1	NONE
RUN/LIGHT	B+A1	A2+L
RUN	B+A1	NONE
START	B + S + A1	NONE

●  
NON-REMOVABLE CONNECTIONS

○  
REMOVABLE CONNECTIONS

**WIRING INSULATED CLIPS**

**NOTE:** IF WIRING INSULATED CLIPS WERE REMOVED FOR SERVICING OF UNIT, THEY SHOULD BE REPLACED TO PROPERLY SECURE YOUR WIRING.

# REPAIR PARTS

TRACTOR - MODEL NO. LT151 (96011011000), PRODUCT NO. 960 11 01-10  
ELECTRICAL

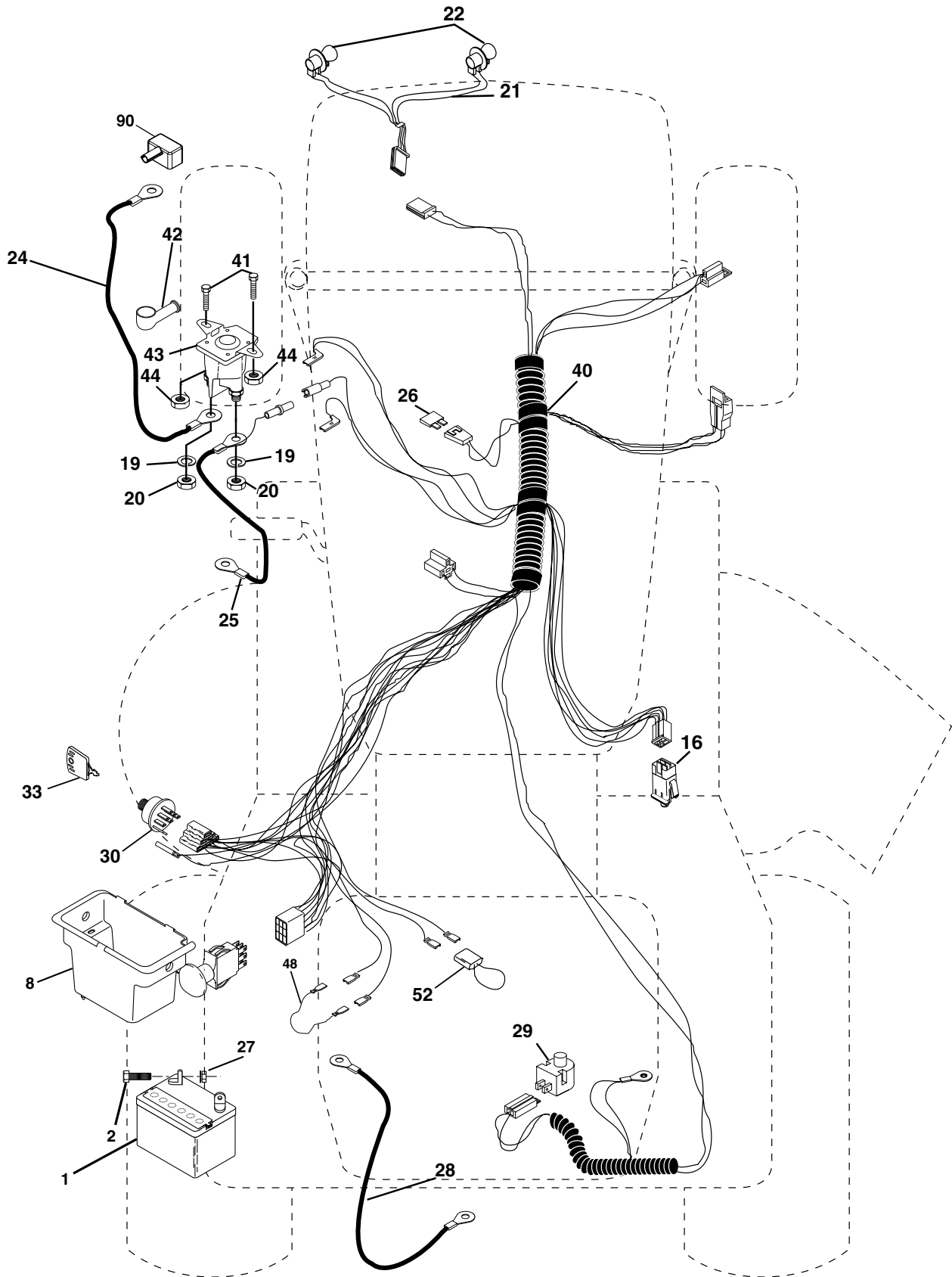

# REPAIR PARTS

TRACTOR - MODEL NO. LT151 (96011011000), PRODUCT NO. 960 11 01-10  
ELECTRICAL

KEY NO.	PART NO.	DESCRIPTION
1	532 14 49-27	Battery
2	874 76 04-12	Bolt Hex Hd 1/4-20 unc x 3/4
8	532 17 66-89	Case Battery Mech Hinge
16	532 17 61-38	Switch Interlock
21	532 17 56-88	Harness Asm Light W/4152j
22	532 00 41-52	Bulb Light #1156
24	532 12 47-80	Cable Battery 6 Ga. 11" red
25	532 14 61-47	Cable Battery 6 Ga. 44" red w/16 wire
26	532 17 51-58	Fuse 20 AMP
27	873 51 04-00	Nut Keps Hex 1/4-20 unc
28	532 12 47-73	Cable Ground 6 Ga. 12" black
29	532 19 27-49	Switch Seat
30	532 19 33-50	Switch Ign
33	532 14 04-01	Key Ign Molded Generic
34	532 11 07-12	Switch Light
40	532 17 94-28	Harness Ign.
41	871 11 04-08	Bolt Blk Fin Hex 1/4 - 20 x 1/2
42	532 13 15-63	Cover Terminal Red
43	532 19 25-07	Solenoid
48	532 14 08-44	Adapter Ammeter Rectangular
52	532 14 19-40	Protection Wire Loop
90	532 18 04-49	Cover Terminal Battery
92	532 19 66-15	Harness Pigtail
93	532 19 25-40	Screw Plastite 10-24-24 x 2.0
94	532 19 18-34	Module Reverse

**NOTE:** All component dimensions given in U.S. inches.  
1 inch = 25.4 mm.

# REPAIR PARTS

TRACTOR - MODEL NO. LT151 (96011011000), PRODUCT NO. 960 11 01-10  
CHASSIS AND ENCLOSURES

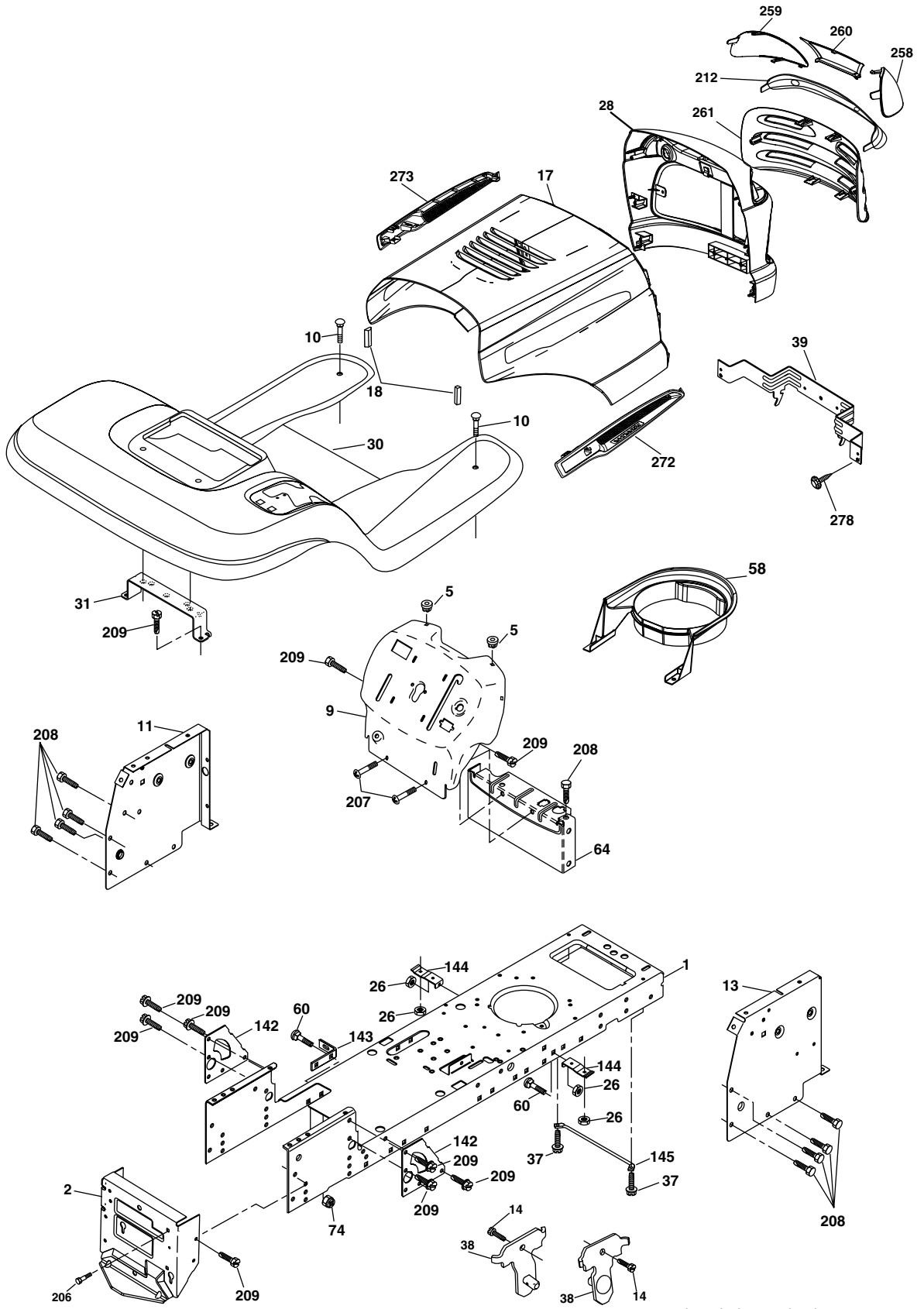

# REPAIR PARTS

TRACTOR - MODEL NO. LT151 (96011011000), PRODUCT NO. 960 11 01-10  
CHASSIS AND ENCLOSURES

KEY NO.	PART NO.	DESCRIPTION
1	532 17 46-19	Chassis Stamping
2	532 17 65-54	Drawbar
5	532 15 52-72	Bumper Hood/Dash
9	532 19 39-37	Dash P/L
10	872 14 06-08	Bolt Carriage 3/8-16 x 1
11	532 17 49-96	Panel Dash Lh
13	532 18 17-19	Panel Dash Rh
14	817 49 06-08	Screw thdrol 3/8-16 x 1/2
17	532 18 88-93	Hood
18	532 18 49-21	Bumper Hood
26	873 80 06-00	Nut Lock Hex W/Ins 3/8-16 unc
28	532 18 35-38	Grille/Len Asm
30	532 19 39-38	Fender Footrest STLT Pnt
31	532 13 99-76	Bracket Support Fender
37	817 49 05-08	Screw Thdrol 6/16-18 x 1/2 TYT
38	532 17 57-10	Bracket, Asm. Pivot, Mower Rear
39	532 17 47-14	Bracket Pivot Laser
58	532 18 71-54	Duct Air
60	872 14 06-06	Bolt Rdhd Sqnk 3/8-16 unc x 3/4
64	532 15 47-98	Dash Lower STLT
74	873 68 06-00	Nut Crownlock 3/8-16 unc
142	532 17 57-02	Plate Reinforcement STLT
143	532 18 66-89	Bracket Swaybar Chassis
144	532 17 55-82	Bracket Pnt Footrest STLT
145	532 15 65-24	Rod Pivot Chassis/Hood
206	532 17 01-65	Bolt Shoulder 5/16-18 TT
207	817 67 05-08	Screw Thdrol 5/16-18 x 1/2
208	817 67 06-08	Screw Thdrol 3/8-16 x 1/2
209	817 00 06-12	Screw Hex Wsh Thdrol 3/8-16- x 3/4
212	532 18 35-48	Insert Lens Reflect
258	532 18 52-14	Lens RH
259	532 18 52-13	Lens LH
260	532 18 52-16	Cover Lens
261	532 18 52-12	Insert Grille
272	532 18 88-96	Vent Hood RH
273	532 18 88-95	Vent Hood LH
278	532 19 16-11	Screw 10 3/4 Single Lead-Hex
--	532 00 54-79	Plug
--	532 18 78-01	Dome Plug Plastic (choke hole)

**NOTE:** All component dimensions given in U.S. inches.  
1 inch = 25.4 mm.

# REPAIR PARTS

TRACTOR - MODEL NO. LT151 (96011011000), PRODUCT NO. 960 11 01-10  
DRIVE

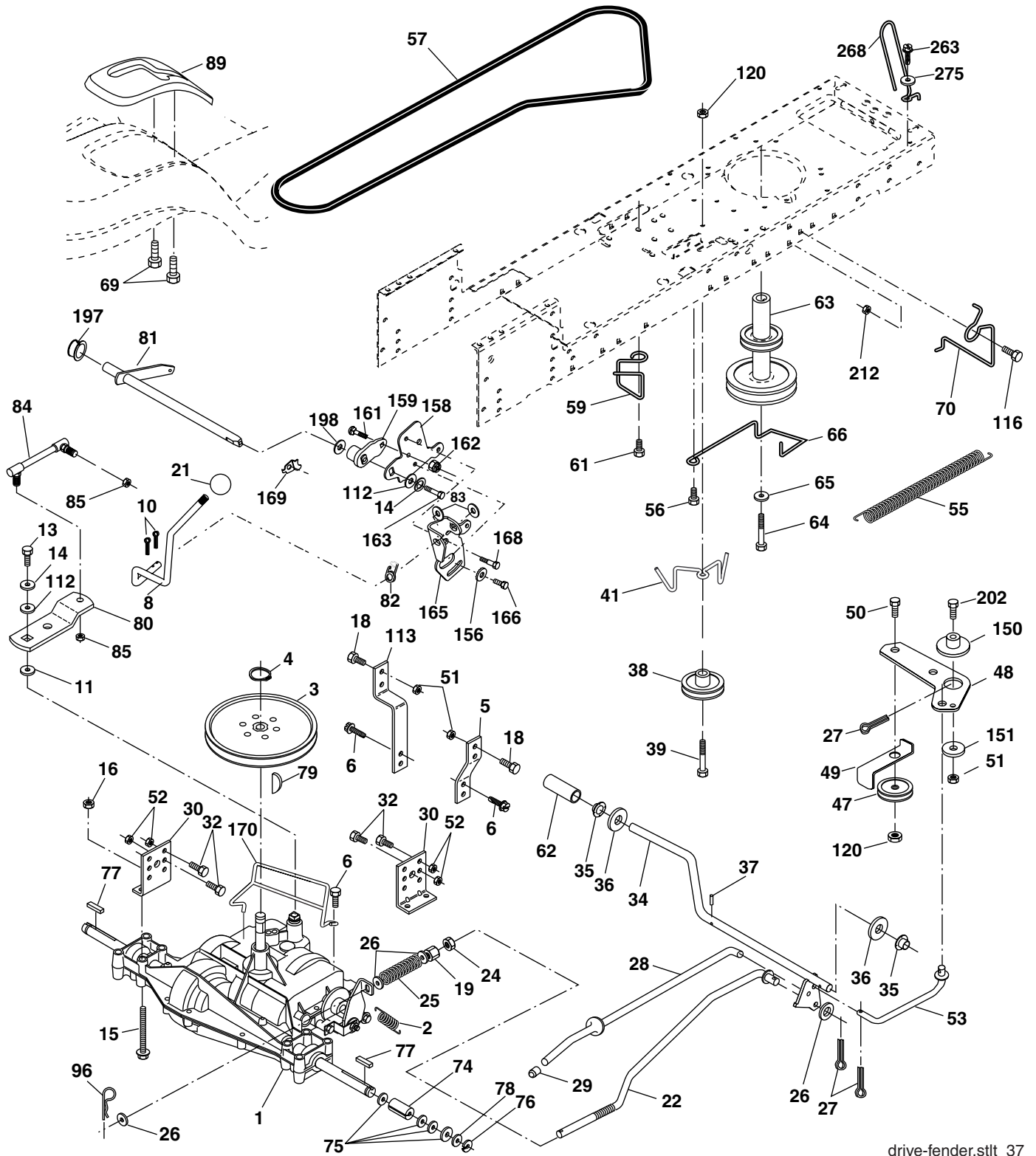



# REPAIR PARTS

**TRACTOR - MODEL NO. LT151 (96011011000), PRODUCT NO. 960 11 01-10  
DRIVE**

KEY PART NO. NO.	DESCRIPTION	KEY PART NO. NO.	DESCRIPTION
1	----- Transaxle, Peerless 206-545C (Order Parts From Transaxle Manufacturer)	64	532 17 39-37 Bolt Hex
2	532 14 66-82 Spring Return Brake T/a Zinc	65	810 04 07-00 Washer Lock Hvy Hlcl Spr 7/16
3	532 12 36-66 Pulley Transaxle 18" tires	66	532 15 47-78 Keeper Belt Engine Foolproof
4	812 00 00-28 Ring Retainer # 5100-62	69	532 14 24-32 Screw Hex Wsh. Hi-Lo 1/4 x 1/2 unc
5	532 12 15-20 Strap Torque 30 Degrees	70	<b>532 13 46-83</b> Guide Belt Mower Drive RH
6	817 06 05-12 Screw Thdrol 5/16-18 x 3/4 TYT	74	532 13 70-57 Spacer Axle
8	532 19 25-02 Rod Shift Fender Adjust STLT	75	532 12 17-49 Washer 25/32 x 1 1/4 x 16 Ga.
10	876 02 04-16 Pin Cotter 1/8 x 1 Cad	76	812 00 00-01 E-ring #5133-75
11	532 10 57-01 Washer Plate Shf 388 Sq Hole	77	532 12 35-83 Key Square 2 0 x 1845/ 1865
13	874 55 04-12 Bolt 1/4-28 unf Gr. 8 W/Patch	78	532 12 17-48 Washer 25/32 x 1-5/8 x 16 Ga.
14	810 04 04-00 Washer Lock Hvy Helical 1/4	79	532 12 50-96 Key Woodruff #9 3/16 x 3/4
15	874 49 05-44 Bolt 5/16-18 Gr. 5	80	532 13 14-86 Arm Shift
16	873 80 05-00 Nut Lock Hx W/Ins 5/16-18 unc Pl	81	532 16 55-94 Shaft Asm Cross Tapered DA/PR 18"
18	874 78 06-16 Bolt, Fin Hex 3/8-16 unc x 1 Gr. 5	82	532 16 57-11 Spring Torsion T/a
19	873 80 06-00 Nut Lock 3/8-16 unc	83	819 17 12-16 Washer 17/32 x 3/4 x 16 Ga.
21	532 12 12-74 Knob	84	532 16 62-28 Transaxle Link
22	532 13 08-04 Rod Brake Blk Zinc 26 840	85	532 15 03-60 Nut Lock Center 1/4 - 28 FNTHD
24	873 35 06-00 Nut Hex Jam 3/8-16 unc	89	532 19 57-20 Console Shift STLT
25	532 10 68-88 Spring Rod Brake 2 00 Zinc	96	532 12 47-88 Retainer Spring 1"
26	819 13 13-16 Washer 13/32 x 13/16 x 16 Ga	112	819 09 12-10 Washer 9/32 x 3/4 x 10 Ga.
27	876 02 04-12 Pin Cotter 1/8 x 3/4 Cad	113	532 12 72-85 Strap Torque LT
28	532 17 57-65 Rod Brake Parking LT/YT	116	872 14 06-08 Bolt Rdhd Sq Neck 3/8-16 x 1
29	532 07 16-73 Cap Brake Parking Black	120	873 90 06-00 Nut Lock Flg. 3/8-16
30	532 17 49-73 Bracket Mtg Transaxle	150	532 17 54-56 Spacer Retainer
32	874 76 05-12 Bolt Hex Hd 5/16-18 unc x 3/4	151	819 13 32-10 Washer 13/32 x 2 x 10 Ga.
34	532 17 55-78 Shaft Asm Pedal Foot	156	532 16 60-02 Washer Srrted 5/16 ID x 1.125
35	532 12 01-83 Bearing Nylon Blk 629 Id	158	532 16 55-89 Bracket Shift Mount
36	819 21 16-16 Washer 21/32 x 1 x 16 Ga	159	532 18 39-00 Hub Shift
37	532 12 49-63 Pin Roll 3/16 x 1"	161	872 14 04-06 Bolt Rdhd Sqnk 1/4-20 x 3/4 Gr. 5
38	532 17 91-14 Pulley Composite	162	873 68 04-00 Nut Crownlock 1/4-20 unc
39	872 11 06-22 Bolt Rdhd 3/8-16 x 2-3/4 Gr. 5	163	874 78 04-16 Bolt Hex Fin 1/4-20 unc x 1 Gr. 5
41	532 17 55-56 Keeper Belt Idler Flat	165	532 16 56-23 Bracket Pivot Lever
47	532 12 77-83 Pulley Idler V Groove Plastic	166	817 49 05-10 Screw 5/16-18 x 5/8
48	532 15 44-07 Bellcrank Clutch Grnd Drv Stl	168	532 16 54-92 Bolt Shoulder 5/16-18 x .561
49	532 12 32-05 Retainer Belt Style Spring	169	532 16 55-80 Plate Fastening STLT/CRD
50	872 11 06-12 Bolt Carr. sh 3/8-16 x 1-1/2 Gr. 5	170	532 18 74-14 Keeper Belt T/A
51	873 68 06-00 Nut Crownlock 3/8-16 unc	197	532 16 96-13 Nyliner Snap-In 5/8" ID
52	873 68 05-00 Nut Crownlock 5/16-18 unc	198	532 16 95-93 Washer Nyl 7/8 Id x .105" Hyd
53	532 19 96-52 Link Clutch	202	872 11 06-14 Bolt 3/8-16 x 1-3/4 Gr. 5
55	532 10 57-09 Spring Return Clutch 6 75	212	532 14 52-12 Nut Hex Flg Lock
56	817 06 06-20 Screw 3/8-16 x 1-1/4	263	<b>817 00 06-12</b> Screw Hexwsh Thdr 3/8-16 x 3/4
57	532 13 82-55 V-Belt Ground Drive	268	<b>532 18 24-02</b> Guard Muffler RH
59	532 16 96-91 Keeper Belt Span Ctr	275	<b>819 13 16-14</b> Washer 13/32 x 1 x 14 Ga.
61	817 12 06-14 Screw 3/8-16 x .875		
62	532 12 48-72 Cover Pedal		
63	<b>532 17 54-10</b> Engine Pulley		

**NOTE:** All component dimensions given in U.S. inches  
1 inch = 25.4 mm

# REPAIR PARTS

TRACTOR - MODEL NO. LT151 (96011011000), PRODUCT NO. 960 11 01-10  
STEERING ASSEMBLY

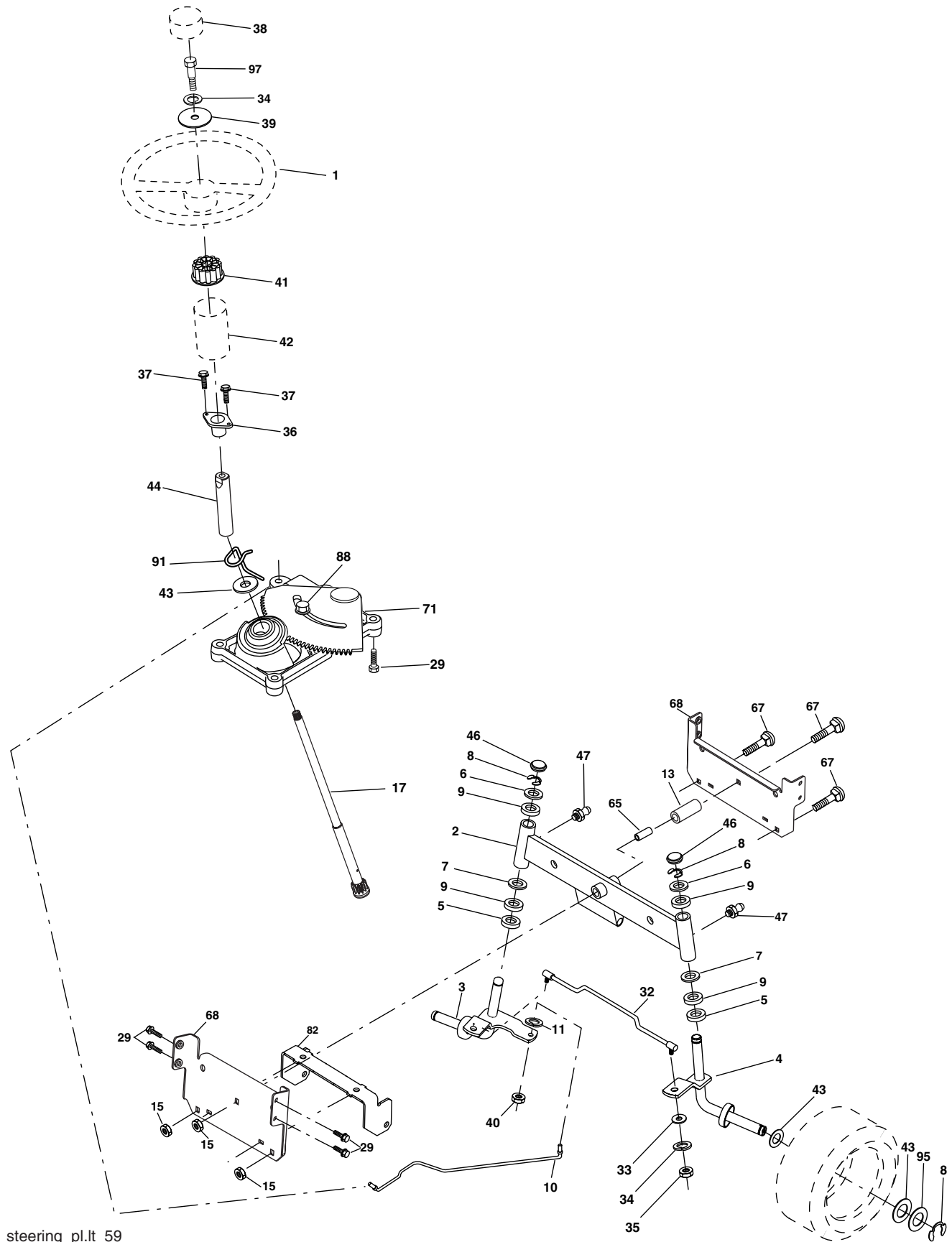

# REPAIR PARTS

TRACTOR - MODEL NO. LT151 (96011011000), PRODUCT NO. 960 11 01-10  
STEERING ASSEMBLY

KEY NO.	PART NO.	DESCRIPTION
1	532 19 39-43	Wheel Steering
2	532 17 51-31	Axle Asm STMP Dropped STL
3	532 16 98-40	Spindle Asm LH
4	532 16 98-39	Spindle Asm RH
5	532 12 49-31	Bearing Race Thrust Harden
6	532 12 17-48	Washer 25/32 x 1-5/8 x 16 Ga.
7	819 27 20-16	Washer 27/32 x 1-1/4 x 16 Ga.
8	812 00 00-29	Ring Klip #t5304-75
9	532 12 49-37	Bearing Col Strg Blk
10	532 17 51-21	Link Drag
11	810 04 06-00	Washer Lock Hvy Hlcl Spr 3/8
13	532 13 65-18	Spacer Brg Axle Front
15	532 14 52-12	Nut Hex Flange Lock
17	532 19 07-53	Shaft Asm Strg
29	817 00 06-12	Screw 3/8-16 x 3/4
32	532 17 18-88	Rod Tie
33	819 11 12-16	Washer 11/32 x 3/4 x 16 Ga.
34	810 04 05-00	Washer Lock 5/16
35	873 54 05-00	Crownlock Nut 5/16-24 unf
36	532 15 50-99	Bushing Strg
37	532 15 29-27	Screw
38	532 19 36-52	Insert Cap Strg Wh
39	819 11 38-12	Washer 11/32 ID x 2 3/8 OD x 12 Ga.
40	873 54 06-00	Nut Crownlock 3/8-24
41	532 18 67-37	Adaptor Wheel Strg
42	532 16 96-34	Boot Steering Shaft
43	532 12 17-49	Washer 25/32 x 1 1/4 x 16 Ga.
44	532 19 07-52	Extension Steering Shaft LR/LT
46	532 12 12-32	Cap Spindle Fr Top Blk
47	532 18 32-26	Fitting Grease
65	532 16 03-67	Spacer Brace Axle
67	872 11 06-18	Bolt, Rdhd Sqnk 3/8-16 x 2-1/4
68	532 16 98-27	Axle, Brace
71	532 17 51-46	Steering Asm.
82	532 19 99-78	Bracket Susp Chassis Front
88	532 17 51-18	Bolt Shoulder 7/16-20
91	532 17 55-53	Clip Steering
95	532 18 89-67	Washer Hardened
97	874 78 05-64	Bolt 5/16-18 UNC x 4 L Gr. 5

**NOTE:** All component dimensions given in U.S. inches.  
1 inch = 25.4 mm.

# REPAIR PARTS

TRACTOR - MODEL NO. LT151 (96011011000), PRODUCT NO. 960 11 01-10  
ENGINE

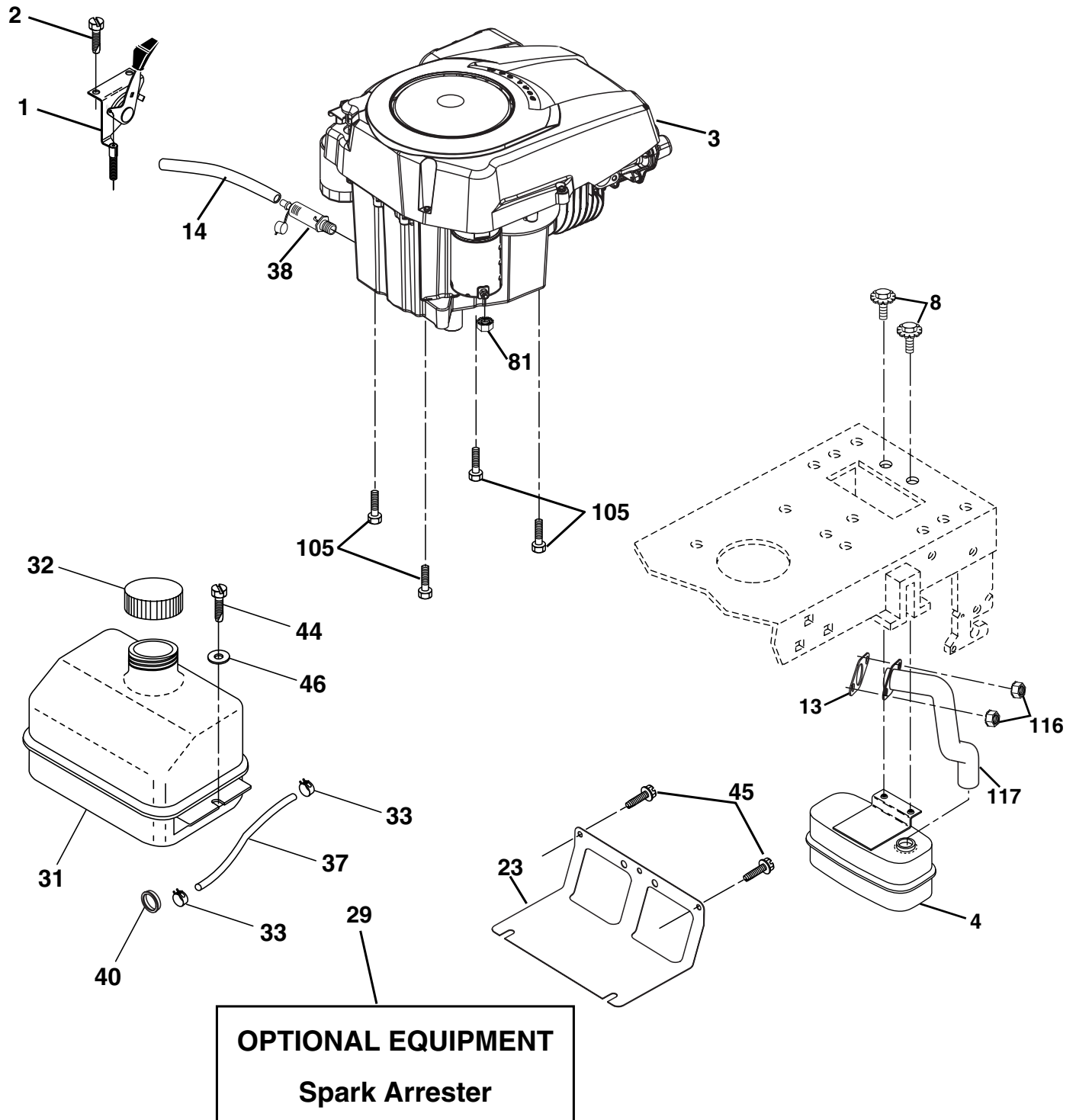

# REPAIR PARTS

TRACTOR - MODEL NO. LT151 (96011011000), PRODUCT NO. 960 11 01-10  
ENGINE

KEY NO.	PART NO.	DESCRIPTION
1	532 17 08-05	Control Th/ch Flag
2	817 72 04-08	Screw Hex Thd Cut 1/4-20 x 5/8 T
3	-----	Engine Kohler Model # SV470 (Order Parts From Engine Manufacturer)
4	532 18 86-55	Muffler
8	532 17 18-77	Bolt 5/16-18 x 3/4
13	532 18 59-09	Gasket Engine
14	532 14 84-56	Tube Drain Oil Easy
23	532 16 98-37	Shield Brn/Dbr Guard
29	532 13 71-80	Kit Spark Arrestor (Flat Scrn)
31	532 18 49-00	Tank Fuel Front
32	532 14 05-27	Cap Asm Fuel W/sym Vented
33	532 12 34-87	Clamp Hose Black
37	532 13 70-40	Line Fuel 20"
38	532 18 16-54	Plug Drain Oil Easy
40	532 12 40-28	Bushing Snap Nyl Blk Fuel Line
44	817 67 04-12	Screw Hexwsh Thdrol 1/4-20 x 3/4
45	817 00 06-12	Screw Hex Wsh Thdrol 3/8-16 x 3/4
46	819 09 14-16	Washer 9/32 x 7/8 X 16 Ga
81	873 51 04-00	Nut 1/4-20
105	817 12 06-16	Screw 3/8-16 x 1
116	532 18 43-62	Nut Hex Flange Toplock M8-1.25
117	532 18 86-54	Tube Exhaust

**NOTE:** All component dimensions given in U.S. inches.  
1 inch = 25.4 mm.

# REPAIR PARTS

TRACTOR - MODEL NO. LT151 (96011011000), PRODUCT NO. 960 11 01-10  
SEAT ASSEMBLY

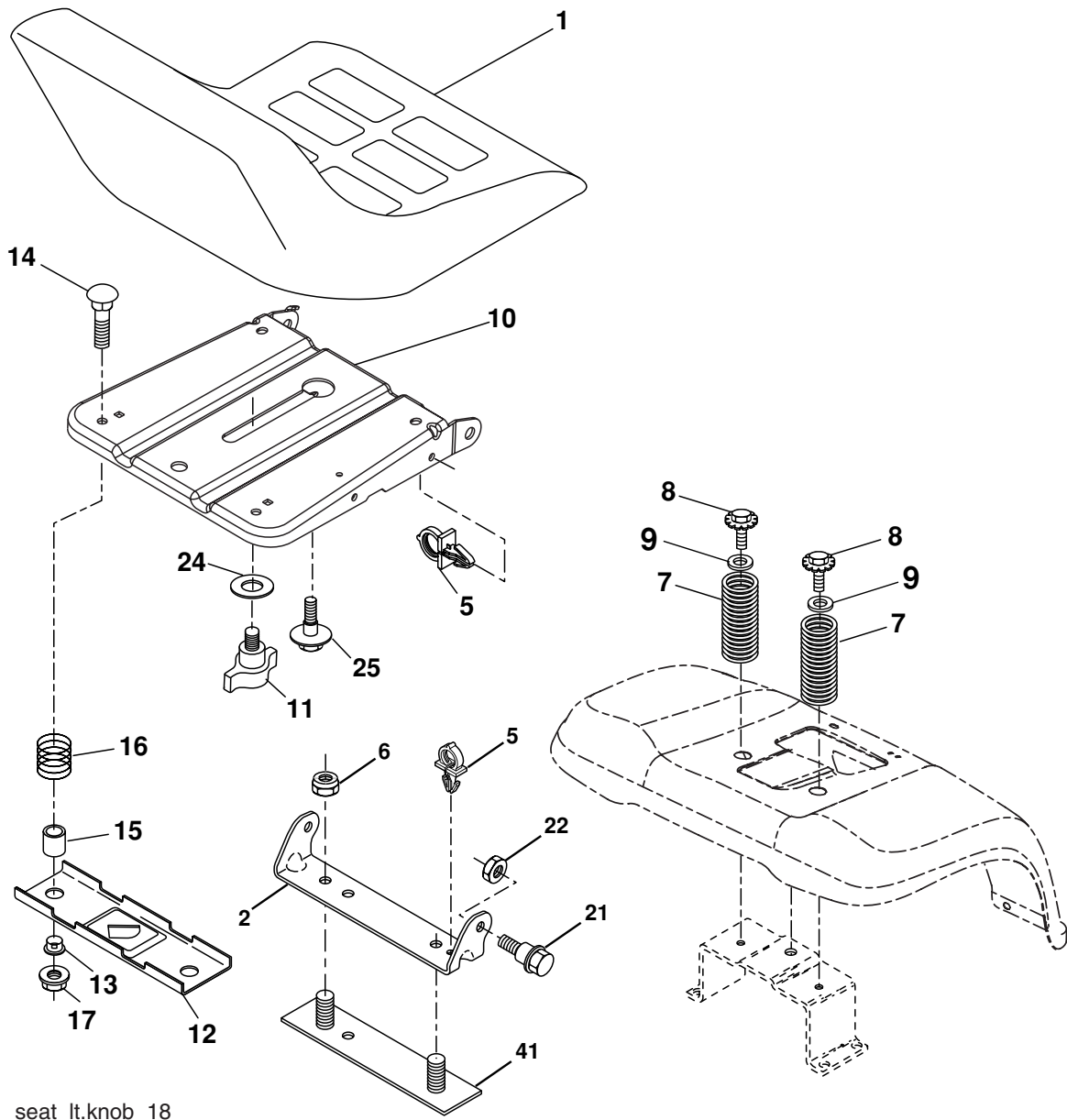

seat\_lt.knob\_18

KEY NO.	PART NO.	DESCRIPTION
1	532 18 49-91	Seat
2	532 14 05-51	Bracket Pivot Seat 8 720
3	871 11 06-16	Bolt Fin Hex 3/8-16 unc x 1
4	819 13 16-10	Washer 13/32 x 1 x 10 Ga.
5	532 14 50-06	Clip Push-In
6	873 80 06-00	Nut Hex w/Ins. 3/8-16 unc
7	532 12 41-81	Spring Seat Cprsn 2 250 Blk Zi
8	817 00 06-16	Screw 3/8-16 x 1-1/2
9	819 13 16-14	Washer 13/32 x 1 x 14 Ga.
10	532 19 55-30	Pan Seat
11	532 16 63-69	Knob Seat
12	532 17 46-48	Bracket Mounting Switch

KEY NO.	PART NO.	DESCRIPTION
13	532 12 12-48	Bushing Snap Blk Nyl 50 Id
14	872 05 04-12	Bolt Rdhd Sqnk 1/4-20 x 1-1/2
15	532 13 43-00	Spacer Split 28 x 96 Yel Zinc
16	532 12 12-50	Spring Cprsn 1 27 Blk Pnt
17	532 12 39-76	Nut Lock 1/4 Lge Flg Gr. 5 Zinc
21	532 17 18-52	Bolt Shoulder 5/16-18 unc
22	873 80 05-00	Nut Hex Lock W/Ins 5/16-18
24	819 17 19-12	Washer 17/32 x 1-3/16 x 12 Ga.
25	532 12 70-18	Bolt Shoulder 5/16-18 x 62
41	532 14 06-75	Strap Asm. Fender

**NOTE:** All component dimensions given in U.S. inches.  
1 inch = 25.4 mm.

# REPAIR PARTS

TRACTOR - MODEL NO. LT151 (96011011000), PRODUCT NO. 960 11 01-10  
DECALS

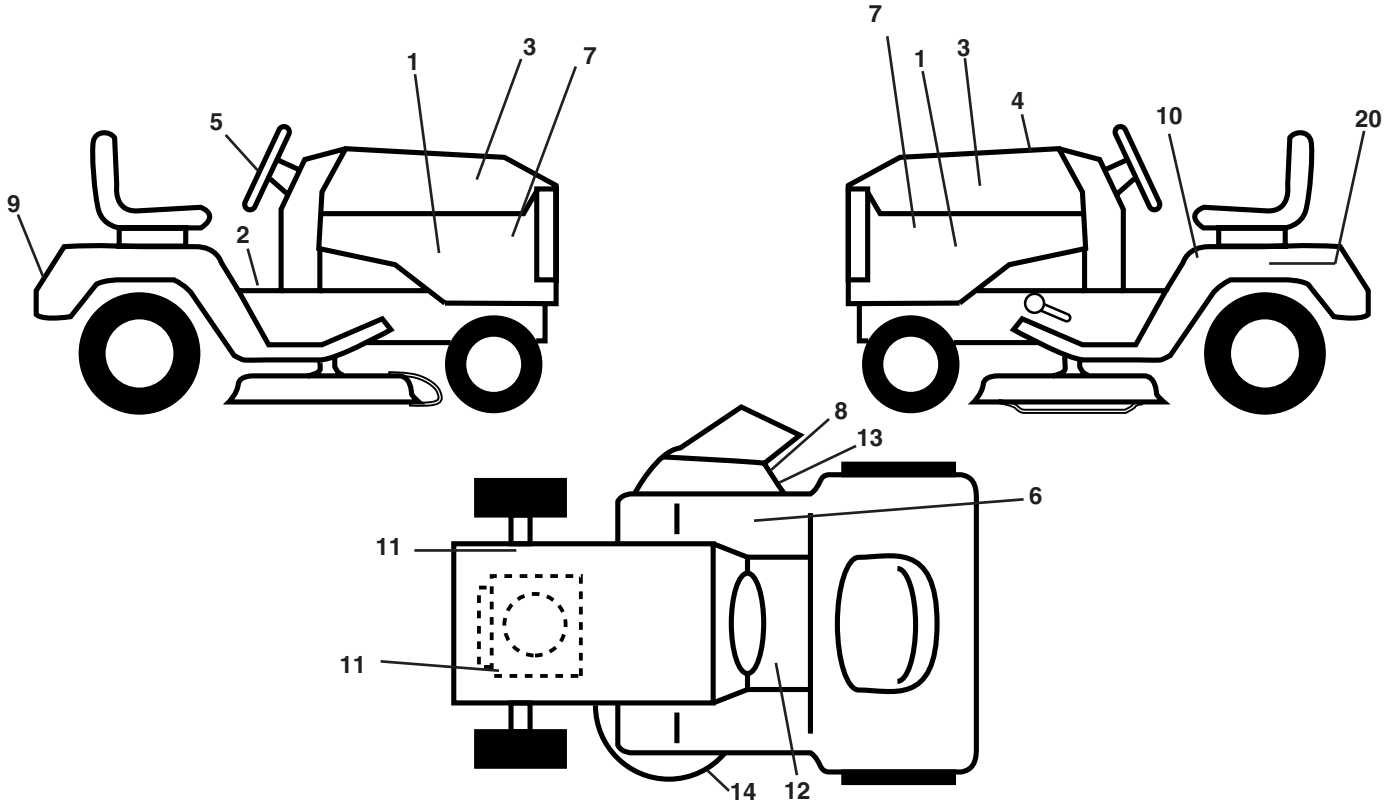

KEY NO.	PART NO.	DESCRIPTION
1	532 19 11-49	Decal Side
2	532 14 08-37	Decal Saddle Brake Parking
3	532 18 89-23	Decal Hood
4	532 40 04-18	Decal Replacement
5	532 18 89-25	Decal Steering
6	532 18 04-32	Decal Fender
7	532 18 89-21	Decal Pnl Side
8	532 18 21-66	Decal Mower Cutting
9	532 18 89-28	Decal Fender
10	532 40 03-89	Decal Read Owner's Manual Syms.
11	532 15 97-36	Decal Chassis Hot Muffler

KEY NO.	PART NO.	DESCRIPTION
12	532 15 97-37	Decal Brake/ Clutch Symbol Lt
13	532 19 63-57	Decal Warning
14	532 19 43-02	Decal V-Belt Schematic
20	532 14 50-05	Decal Bat Dan/Psn
--	532 18 82-52	Pad Footrest LH STLT
--	532 16 25-98	Decal Drawbar
--	532 18 82-53	Pad Footrest RH STLT
--	532 13 83-11	Decal Handle Lift Height Adjust
--	532 40 05-83	Manual Operator's (Euro)
--	532 40 14-56	Manual Operator's (Scan)
--	532 40 14-57	Manual Operator's (Ebloc)
--	532 40 14-58	Manual Operator's (Baltic)

## WHEELS & TIRES

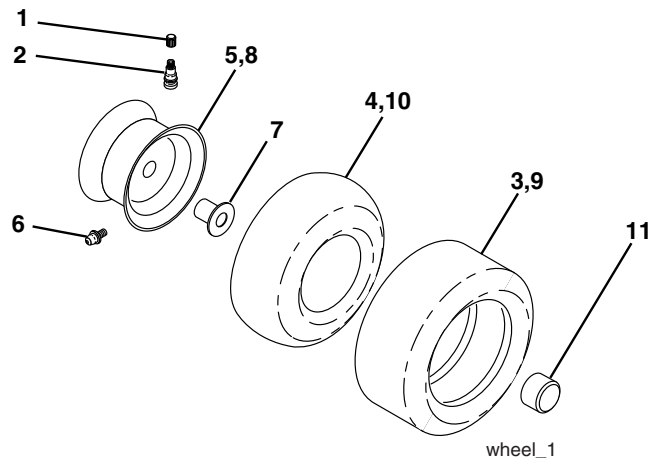

KEY NO.	PART NO.	DESCRIPTION
1	532 05 91-92	Cap Valve Tire
2	532 06 51-39	Stem Valve
3	532 10 62-22	Tire F Ts 15 x 6 0 - 6 Service
4	532 05 99-04	Tube Front (Service Item Only)
5	532 13 83-36	Rim Asm 6" front Silver Service
6	532 12 49-57	Fitting Grease (Front Wheel Only)
7	532 12 49-59	Bearing Flange (Front Wheel Only)
8	532 13 83-37	Rim Asm 8"rear Silver Service
9	532 10 62-68	Tire R Ts 18 x 9 5-8 C Service
10	532 12 49-26	Tube Rear (Service Item Only)
11	532 17 50-39	Cap Axle Blk 1 50 x 1 00
--	532 14 43-34	Sealant, Tire ( 10 oz. Tube)

**NOTE:** All component dimensions given in U.S. inches.  
1 inch = 25.4 mm.



# REPAIR PARTS

TRACTOR - MODEL NO. LT151 (96011011000), PRODUCT NO. 960 11 01-10  
MOWER DECK

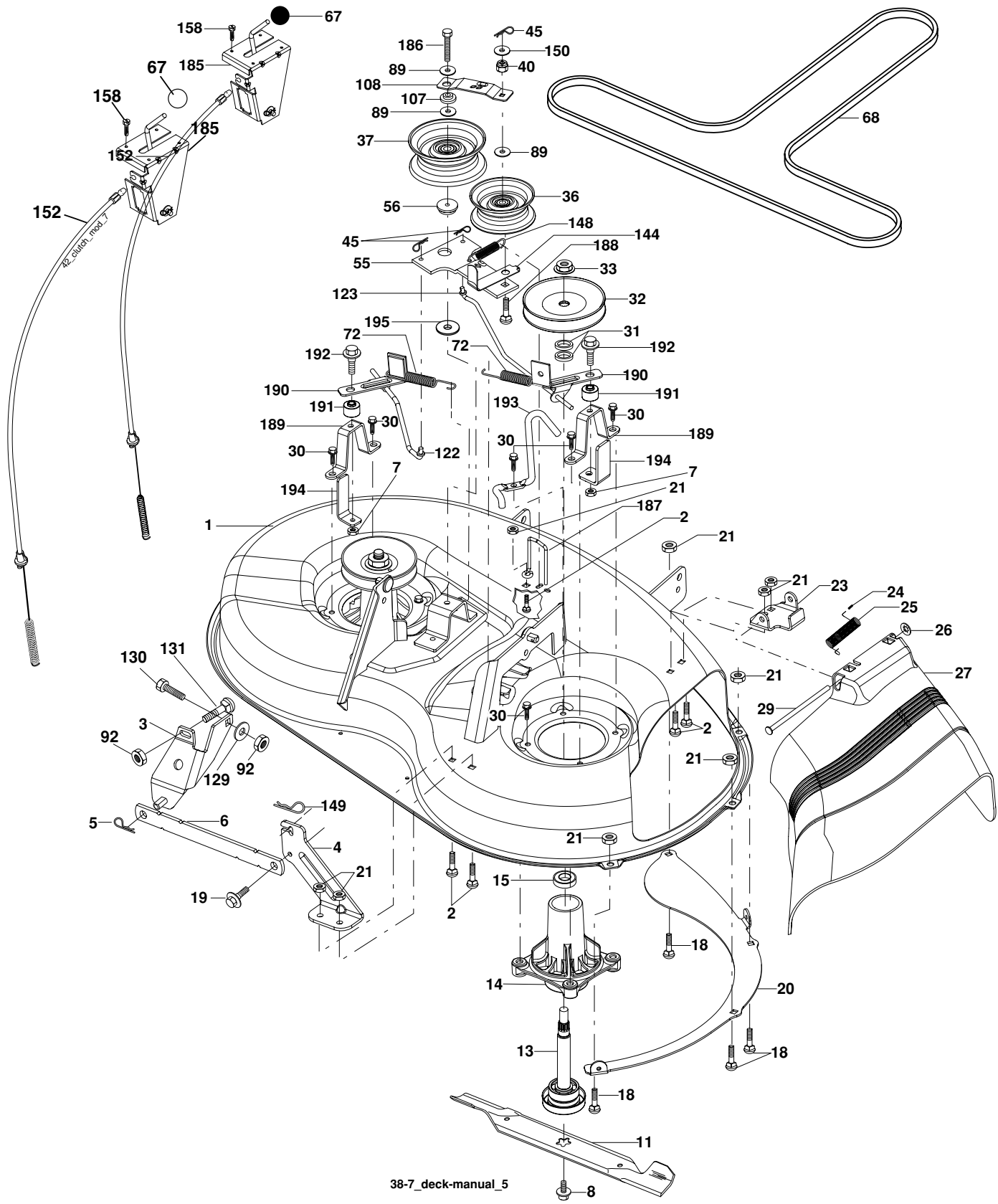



# REPAIR PARTS

TRACTOR - MODEL NO. LT151 (96011011000), PRODUCT NO. 960 11 01-10  
MOWER DECK

KEY NO.	PART NO.	DESCRIPTION	KEY NO.	PART NO.	DESCRIPTION
1	532 19 25-56	Mower Housing Assembly	92	873 80 06-00	Nut Lock Hex w/Ins. 3/8-16 unc
2	872 14 05-06	Bolt Carriage 5/16-18 x 3/4	107	532 13 35-02	Spacer Retainer
3	532 13 80-17	Bracket Asm Fr. Sway Bar	108	532 13 35-03	Stiffener, Idler Arm
4	532 19 25-68	Bracket Deck Sway Bar 38"/42"	122	532 19 25-75	Rod, Brake LH
5	532 12 46-70	Retainer Spring	123	532 19 25-76	Rod, Brake RH
6	532 17 80-24	Bar Sway Deck	129	819 13 13-12	Washer 13/32 x 3/16 x 12 Ga.
7	873 80 05-00	Nut Lock Hex w/Ins. 5/16-18 unc	130	874 78 06-16	Bolt Fin Hex 3/8-16 unc x 1 Gr. 5
8	532 19 30-03	Bolt 3/8-24 x 1.25 Gr. 8	131	872 14 06-08	Bolt Rdhd Sqnk 3/8-16 unc
11	532 19 39-57	Blade Mower	144	532 19 34-14	Keeper Belt Idler Tension
13	532 19 28-72	Shaft Assembly, Mandrel, Vented	148	532 16 90-22	Spring Return Idler
14	532 18 72-81	Housing, Mandrel, Vented	149	532 16 58-98	Retainer Spring Yellow
15	532 11 04-85	Bearing, Ball, Mandrel	150	819 09 12-10	Washer 9/32 x 3/4 x 10 Ga.
18	872 14 05-05	Bolt Rdhd Sqnk 5/16-18 x 5/8	152	532 19 32-35	Clutch Cable 38"/46"
19	532 13 28-27	Bolt, Shoulder	158	817 72 04-08	Screw Hex Thd Cut 1/4-20 x 1/2
20	532 40 00-95	Baffle Vortex Front	185	532 18 82-34	Head Asm Cable Clutch
21	873 68 05-00	Nut	186	817 49 06-44	Screw Hex Wsh Thdrol 3/8-16 x 2-3/4
23	532 19 25-57	Bracket, Mower Deflector	187	532 19 34-12	Keeper Belt
24	532 10 53-04	Cap, Sleeve	188	532 16 58-91	Bolt Carriage Idler
25	532 19 70-26	Spring, Torsion, Deflector	189	532 19 25-59	Stand, Brake
26	532 11 04-52	Nut, Push	190	532 19 25-60	Arm, Brake
27	532 40 14-72	Shield, Deflector	191	532 19 25-61	Spacer, Brake
29	532 13 14-91	Rod, Hinge	192	532 19 37-82	Bolt/Washer Asm 5/16-18
30	532 17 39-84	Screw Thdrol.	193	532 19 34-13	Keeper Belt Rh Mandrel
31	532 18 76-90	Washer, Spacer	194	532 19 41-05	Guard Brake
32	532 15 35-32	Pulley, Mandrel	195	819 13 32-10	Washer
33	532 40 02-34	Nut, Flange Lock Top	--	532 19 25-58	Brake Assembly (Includes Stand, Arm and Guard Components)
36	532 13 14-94	Pulley, Idler, Flat	--	532 19 28-70	Mandrel Assembly (Includes Housing, Shaft and Shaft Hard- ware Only - Pulley Not Included)
37	532 19 31-98	Pulley Idler Flat	--	532 19 34-72	Replacement Mower, Complete
40	873 68 06-00	Nut, Crownlock 3/8-16 unc			
45	532 12 47-88	Retainer			
55	532 13 38-40	Idler Arm Assembly			
56	532 16 57-23	Spacer, Retainer			
67	532 10 69-32	Knob			
68	532 19 32-14	V-Belt			
72	532 19 32-16	Spring Brake Return			
89	819 13 13-11	Washer 13/32 x 13/16 x 11 Ga.			

**NOTE:** All component dimensions given in U.S. inches.  
1 inch = 25.4 mm.

# REPAIR PARTS

TRACTOR - MODEL NO. LT151 (96011011000), PRODUCT NO. 960 11 01-10  
MOWER LIFT

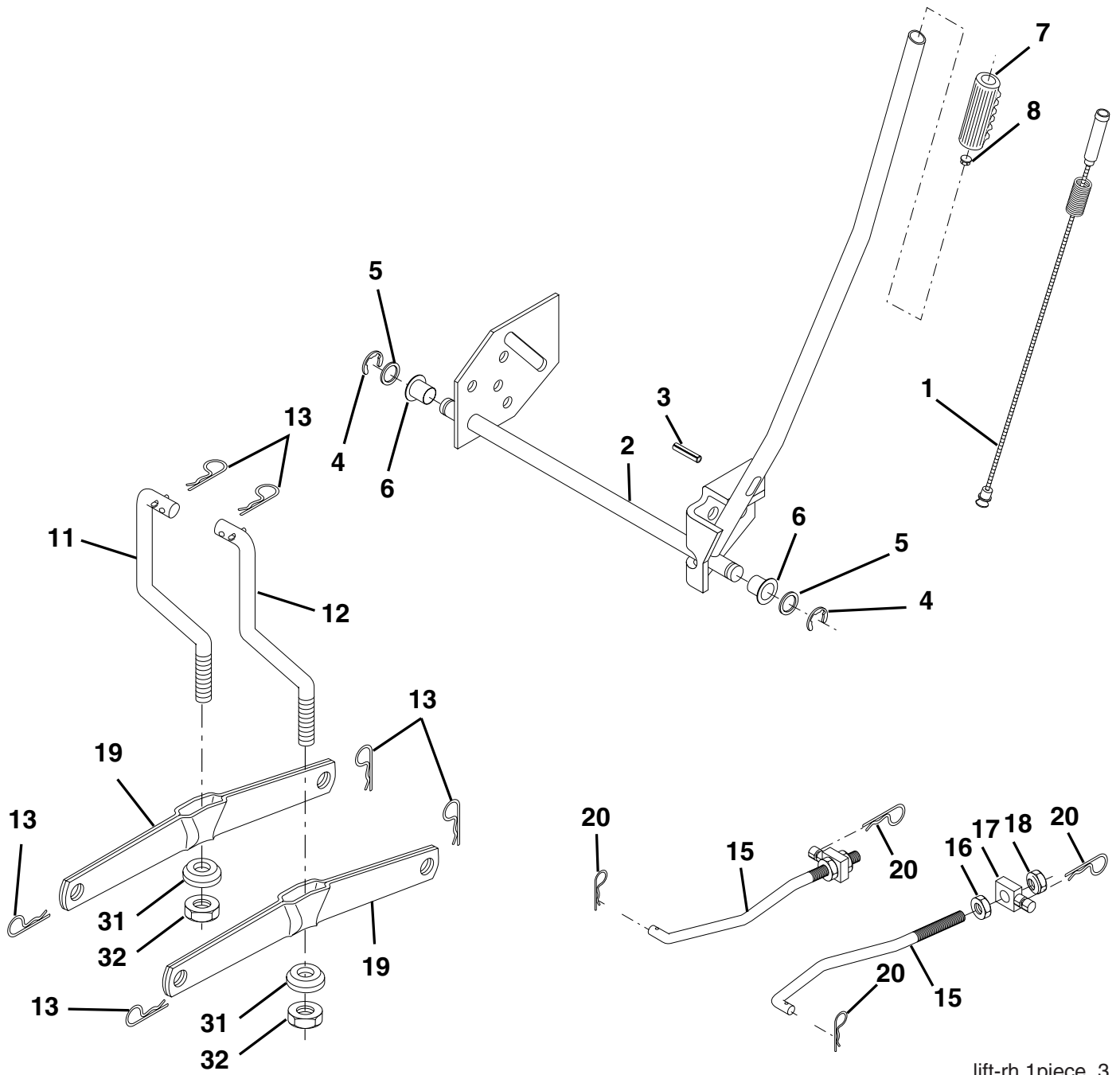

lift-rh.1piece\_3

# REPAIR PARTS

TRACTOR - MODEL NO. LT151 (96011011000), PRODUCT NO. 960 11 01-10  
MOWER LIFT

KEY NO.	PART NO.	DESCRIPTION
1	532 15 94-60	Wire Asm Inner/Spring W/plunger
2	532 15 94-71	Shaft Asm Lift
3	532 10 57-67	Pin Groove
4	812 00 00-02	E Ring #5133-62
5	819 21 16-21	Washer PLTD 21/32 x 1 x 21Ga.
6	532 12 01-83	Bearing Nylon Blk 629 Id
7	532 10 94-13	Grip Handle Bicycle
8	532 12 45-26	Button Plunger Black
11	532 13 98-65	Link Lift LH
12	532 13 98-66	Link Lift RH
13	532 12 46-70	Retainer Spring
15	532 17 32-88	Link Front
16	873 35 08-00	Nut Jam Hex 1/2-13 unc
17	532 17 56-89	Trunnion Blk Zinc
18	873 80 08-00	Nut Lock W/wsh 1/2-13 unc
19	532 13 98-68	Arm Suspension Rear
20	532 16 35-52	Spring, Retainer
31	532 16 98-65	Bearing Pvt. Lift
32	873 54 06-00	Nut Crownlock 3/8-24

**NOTE:** All component dimensions given in U.S. inches.  
1 inch = 25.4 mm.