

CTH150 XP

Spare parts

Ersatzteile

Pièces détachées

Reserve onderdelen

Repuestos

Reservdelar

ILLUSTRATED PARTS LIST

MFG. ID NO. 96061006600

CUSTOMER CATALOG NO. CTH150 XP

PRODUCT NO. 960 61 00-66

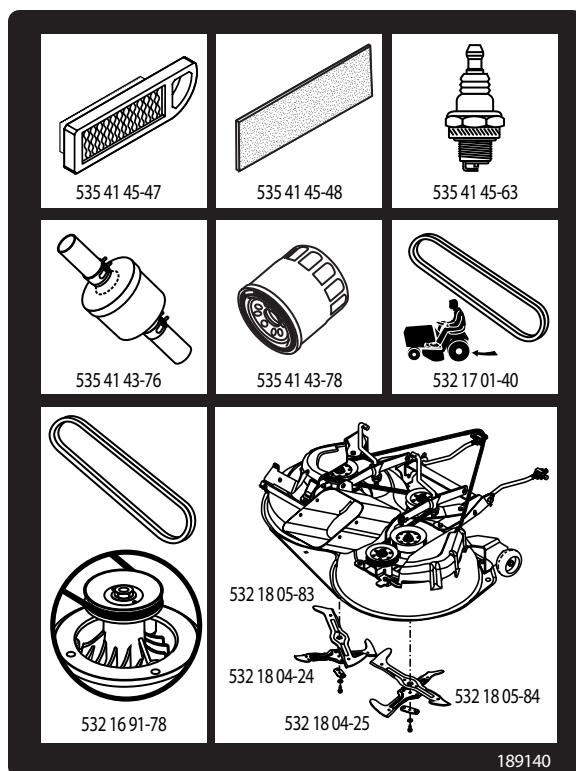

REPAIR PARTS

TRACTOR- -MODEL NO. CTH150 XP (96061006600), PRODUCT NO. 960 61 00-66
DECALS

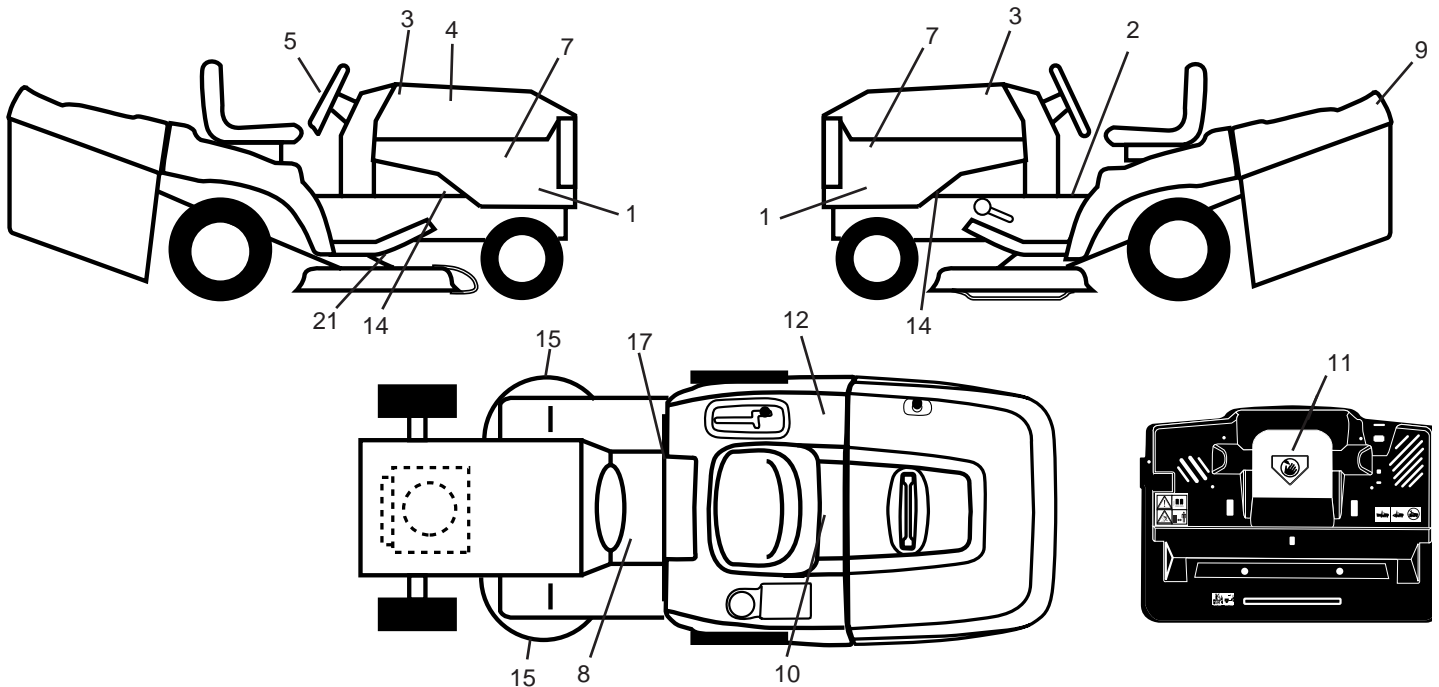

KEY NO.	PART NO.	DESCRIPTION
1	532 19 11-44	Decal Side Panel
2	532 40 03-89	Decal Warning Symbols CE
3	532 18 89-22	Decal Hood
4	532 18 91-40	Decal Replacement
5	532 18 89-25	Decal Wheel Logo
7	532 18 89-21	Decal Hood Rh/LH
8	532 15 97-37	Decal Brake/Clutch Symbol
9	532 18 89-26	Decal Fender Logo
10	532 14 50-05	Decal Bat Dan/Poi P/L Sym Wpn
11	532 18 21-66	Decal Mower Cut Finger Symbol
12	532 18 04-32	Decal Fender 100 DB/CE
14	532 15 97-36	Decal Chassis Hot Muffler

KEY NO.	PART NO.	DESCRIPTION
15	532 19 68-42	Decal Warning Cut Finger
17	532 14 08-37	Decal Saddle Brake Parking
21	532 16 62-86	Decal Deck Sch 92 CRD
--	532 16 69-60	Decal Bypass
--	532 13 83-11	Decal Lift Handle
--	532 18 10-91	Pad Footrest LH
--	532 18 10-90	Pad Footrest RH
--	532 18 04-35	Decal Rear Plate
--	532 40 09-75	Manual Operator's (Euro)
--	532 40 09-76	Manual Operator's (Scan)
--	532 40 14-15	Manual Operator's (E-Bloc)
--	532 40 14-16	Manual Operator's (Baltic)

WHEELS & TIRES

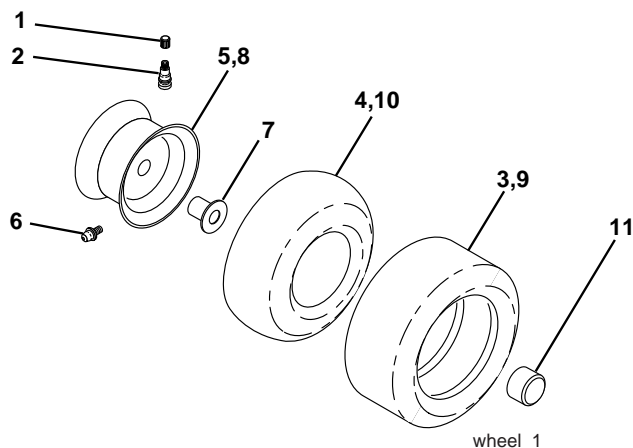

KEY NO.	PART NO.	DESCRIPTION
1	532 05 91-92	Cap Value Tire
2	532 06 51-39	Stem Value
3	532 10 62-22	Tire F Ts 15 x 6 0 - 6 Service
4	532 05 99-04	Tube Inner Front #35060
5	532 13 83-36	Rim Asm 6" front Service
6	532 12 49-57	Fitting Grease
7	532 12 49-59	Bearing Flange
8	532 13 83-37	Rim Asm 8" rear Service
9	532 12 20-82	Tire R Ts 20 x 10-8 Service
10	532 12 49-26	Tube Rear 9 5 x 8 Service
11	532 17 50-39	Cap Axle Blk 1 50 x 1 00
--	532 14 43-34	Sealant, Tire (10 oz. tube)

NOTE: All component dimensions given in U.S. inches.
1 inch = 25.4 mm

TRACTOR- -MODEL NO. CTH150 XP (96061006600), PRODUCT NO. 960 61 00-66 SCHEMATIC

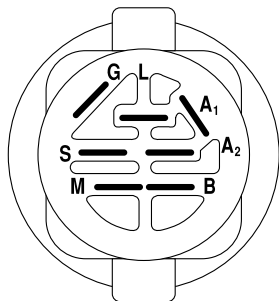
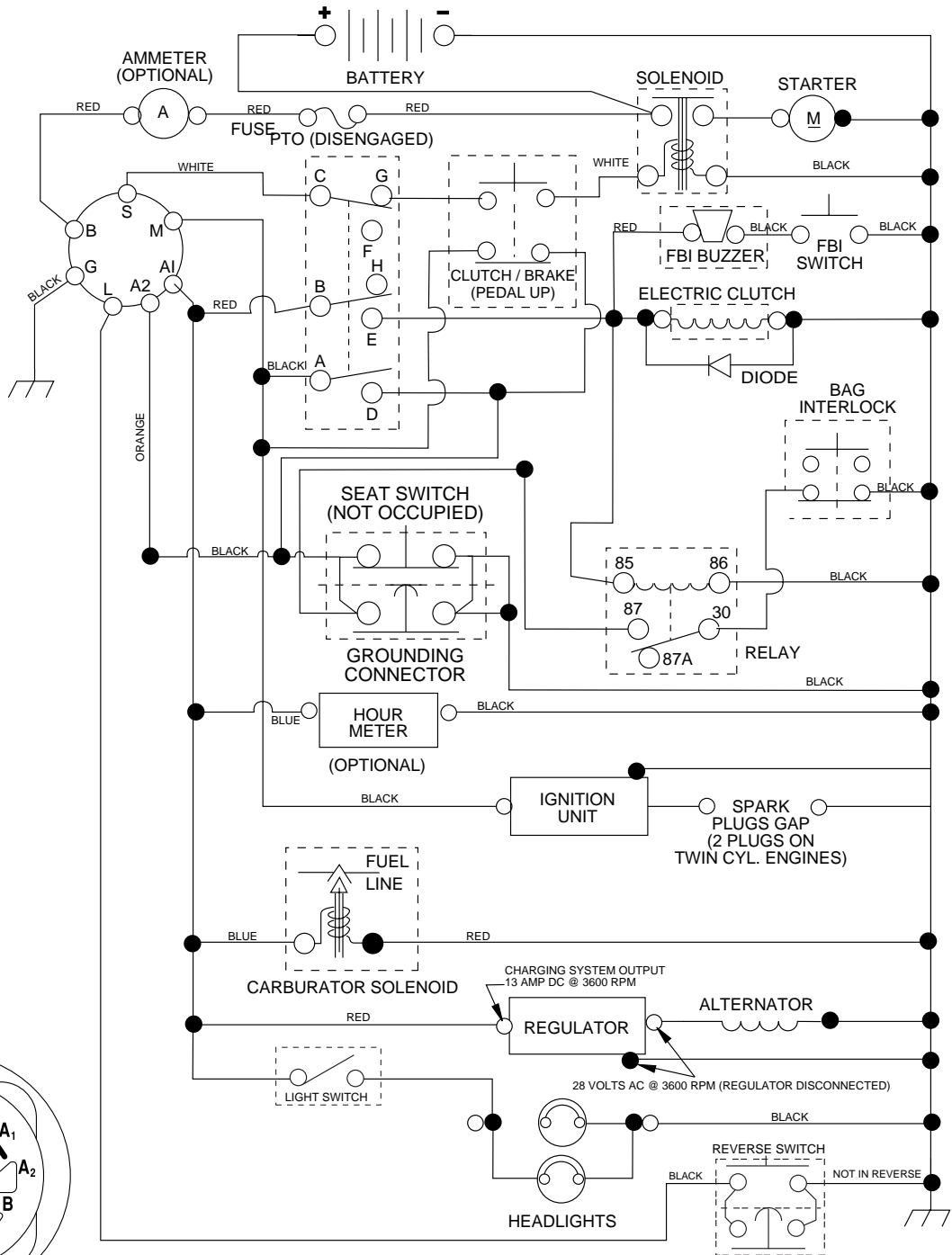

IGNITION SWITCH

POSITION	CIRCUIT	"MAKE"
OFF	M+G+A1	
RUN/OVERRIDE	B+A1	
RUN	B+A1	L+A2
START	B + S + A1	

WIRING INSULATED CLIPS
NOTE: IF WIRING INSULATED CLIPS WERE REMOVED FOR SERVICING OF UNIT, THEY SHOULD BE REPLACED TO PROPERLY SECURE YOUR WIRING.

03047

PTO SWITCH

POSITION	CIRCUIT
OFF	C + G, B + H
ON	C + F, B + E, A + D

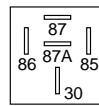

RELAY

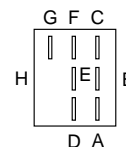

NON-REMOVABLE CONNECTIONS

REMOVABLE CONNECTIONS

REPAIR PARTS

TRACTOR- -MODEL NO. CTH150 XP (96061006600), PRODUCT NO. 960 61 00-66
ELECTRICAL

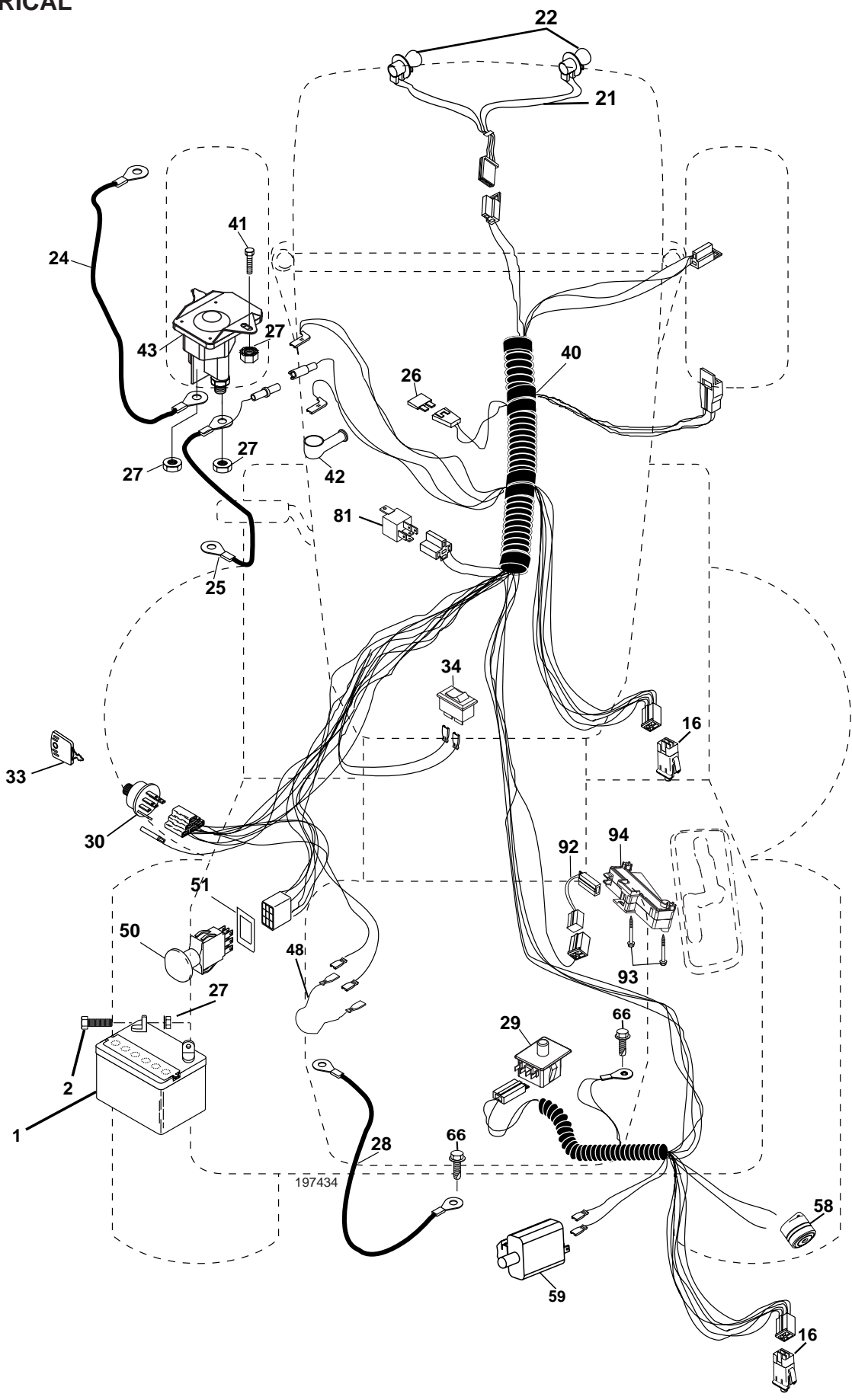

REPAIR PARTS

TRACTOR- -MODEL NO. CTH150 XP (96061006600), PRODUCT NO. 960 61 00-66
ELECTRICAL

KEY NO.	PART NO.	DESCRIPTION
1	532 14 49-27	Battery
2	874 76 04-12	Bolt Hex Hd 1/4-20 unc x 3/4
16	532 17 61-38	Switch Interlock
21	532 17 56-88	Harness Asm Light W/4152J
22	532 00 41-52	Bulb Light #1156
24	532 12 47-80	Cable Starter 6 Ga. 11" Red
25	532 16 59-87	Cable Battery Crd 56" Red
26	532 17 51-58	Fuse
27	873 51 04-00	Nut Keps Hex 1/4-20 unc
28	532 12 77-25	Cable Ground 6 Ga. 18" Black
29	532 19 27-49	Switch Seat
30	532 19 33-50	Switch Ignition
33	532 14 04-01	Key Ign Molded
34	532 11 07-12	Switch Light
40	532 19 74-34	Harness Ign
41	871 11 04-08	Bolt Flk Fin Hex 1/4-20 unc x 1/2
42	532 13 15-63	Cover Terminal Red
43	532 19 25-07	Solenoid
48	532 14 08-44	Adapter Ammeter Rectangular
50	532 17 46-51	Switch PTO
51	532 14 04-05	Ring Retainer
52	532 14 19-40	Protection Wire Loop
58	532 16 94-19	Buzzer Crd
59	532 18 03-79	Switch FBI CRD
66	817 49 06-08	Screw Thdrol 3/8-16 x 1/2 Ty-Tt
81	532 10 97-48	Relay Asm
92	532 19 66-15	Harness Pigtail
93	532 19 25-40	Screw Plastite 10-14 x 2.0
94	532 19 18-34	Module Reverse

NOTE: All component dimensions given in U.S. inches.
1 inch = 25.4 mm.

REPAIR PARTS

**TRACTOR- -MODEL NO. CTH150 XP (96061006600), PRODUCT NO. 960 61 00-66
CHASSIS AND ENCLOSURES**

KEY NO.	PART NO.	DESCRIPTION	KEY NO.	PART NO.	DESCRIPTION
1	532 17 46-20	Chassis	164	532 16 56-05	Support Battery CRD
2	532 18 03-84	Drawbar	165	532 18 11-00	Cover Battery
3	817 06 06-12	Screw 3/8-16 x 3/4	170	532 19 94-88	Backplate CRD
5	532 15 52-72	Bumper Hood/Dash	171	872 14 06-20	Bolt Rdhd Sqnk 3/8-16 x 2-1/2 Gr. 5
6	532 18 44-19	Saddle	172	819 13 20-16	Washer 13/32 x 1-1/4 x 16 Ga.
8	532 12 64-71	Clip Insulator 13/32 Mtg. Hole	173	873 51 06-00	Nut, Keps Hex 3/8-16 unc
9	532 19 45-73	Dash	175	532 18 82-03	Door Trap
10	872 14 06-08	Bolt, Carriage 3/8-16 x 3/4	179	532 18 82-02	Rod Pivot FBI CRD
11	532 17 49-96	Panel, Dash, L.H.	184	532 17 46-62	Bracket Actuator Bagger CRD
13	532 17 21-06	Panel, Asm. Dash R.H.	185	532 18 11-01	Knob Rod Brake Parking
15	874 18 05-12	Screw, Machine, Truss Head 5/16-18 unc x 3/4	186	532 16 07-93	Latch Asm Mulch/Bagger
16	873 51 05-00	Nut	187	532 12 50-04	Nut Weld
17	532 18 88-93	Hood	188	819 06 12-16	Washer #10
18	532 18 49-21	Bumper Hood	189	810 07 10-00	Washer Lock #10
24	874 78 06-16	Bolt	190	871 08 10-10	Screw Pan Hd Phillip 10-24 x 5/8
25	819 13 13-12	Washer 13/32 x 13/16 x 12 Ga.	198	532 16 89-37	Nut, Push
26	873 80 06-00	Nut	205	817 49 06-08	Screw Thdrol 3/8-16 x 1/2
28	532 18 35-38	Grille /Lens Asm (Includes Key Nos. 212, 258 - 261)	207	817 67 05-08	Screw Thdrl. 5/16-18 x 1/2
30	532 19 73-76	Fender	208	817 67 06-08	Screw Thdrol 3/8-16 x 1/2
31	532 16 51-56	Bracket, Fender Support	209	817 00 06-12	Screw Hex Wsh Thdrol 3/8-16
33	532 18 10-57	Footrest, L.H.	212	532 18 35-48	Insert Lens Reflect
34	532 18 10-58	Footrest, R.H.	256	532 18 13-61	Cover Fender Rack
35	872 11 06-06	Bolt	258	532 18 52-14	Lens RH
37	817 49 05-08	Screw Thdrol 5/16-18 x 1/2 TYT	259	532 18 52-13	Lens LH
38	532 18 17-48	Bracket Asm Pivot Mower Rear	260	532 18 52-16	Cover Lens
39	532 17 47-14	Bracket Pivot	261	532 18 52-12	Insert Grille
58	532 18 42-70	Duct Air Engine	265	532 18 57-04	Seal RH Side Bagger
69	532 14 24-32	Screw HxWsh Hi-Lo	266	532 18 57-03	Seal LH Side Bagger
89	532 19 73-77	Console	272	532 18 88-96	Vent Hood RH
145	532 15 65-24	Rod Pivot Chassis/Hood	273	532 18 88-95	Vent Hood LH
162	532 18 03-82	Bracket Exten Chassis Lh CRD	278	532 19 16-11	Screw 10 x 3/4 Single Lead Hex
163	532 18 03-83	Bracket Exten Chassis Rh CRD			

NOTE: All component dimensions given in U.S. inches.
1 inch = 25.4 mm.

REPAIR PARTS

TRACTOR- -MODEL NO. CTH150 XP (96061006600), PRODUCT NO. 960 61 00-66
DRIVE

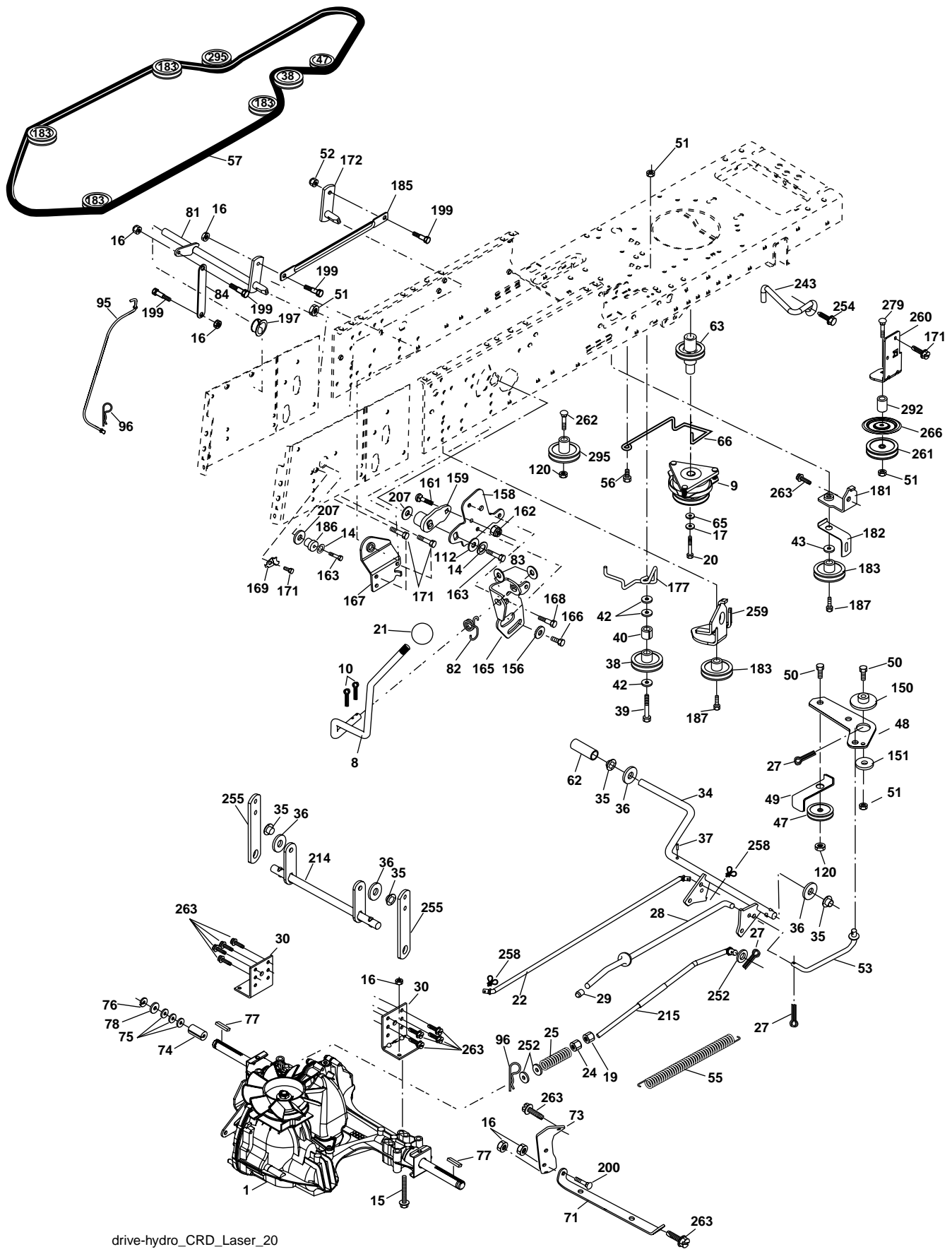

REPAIR PARTS

TRACTOR- -MODEL NO. CTH150 XP (96061006600), PRODUCT NO. 960 61 00-66
DRIVE

KEY NO.	PART NO.	DESCRIPTION	KEY NO.	PART NO.	DESCRIPTION
1	-----	Transaxle Hydro Gear 321-0510 (Order parts from transaxle manufacturer)	83	819 17 12-16	Washer 17/32 x 3/4 x 16 Ga.
8	532 19 27-06	Rod, Shift	84	532 17 00-07	Link, Transaxle
9	532 19 81-43	Clutch Ele	95	532 17 00-15	Control Asm Bypass Hydro
10	876 02 04-16	Pin, Cotter 1/8 x 1	96	532 12 47-88	Spring, Retainer 1"
14	810 04 04-00	Washer, Lock Hvy Helical	112	819 09 12-10	Washer 9/32 x 3/4 x 10 Ga.
15	874 49 05-44	Bolt Hex Flghd. 5/16-18 Gr. 5	120	873 90 06-00	Nut Lock Flg. 3/8-16 unc
16	873 80 05-00	Nut, Lock Hex w/Ins 5/16-18 unc	150	532 16 58-50	Bushing, Bellcrank Grnd Dr.
17	532 12 61-97	Washer 1-1/2 OD x 15/32 ID x .250	151	819 13 32-10	Washer 13/32 x 2 x 10 Ga.
19	873 80 06-00	Nut Lock Hex W/Ins 3/8-16 unc	156	532 16 60-02	Washer Srrted 5/16ID x 1.125
20	532 17 39-37	Bolt, Hex 7/16-20 x 4	158	532 16 55-89	Bracket Shift Mount
21	532 12 12-74	Knob Duckhead 1/4-13 unc Blk	159	532 18 39-00	Hub Shift
22	532 17 56-07	Rod, Brake	161	872 14 04-06	Bolt Rdhd Sqnk 1/4-20 x 3/4 Gr. 5
24	873 35 06-00	Nut	162	873 68 04-00	Nut Crownlock 1/4-20 unc
25	532 19 20-36	Spring, Rod, Brake	163	874 78 04-16	Bolt Hex Fin 1/4-20 unc x 1 Gr. 5
27	876 02 04-12	Pin, Cotter 1/8 x 3/4	165	532 16 56-23	Bracket Pivot Lever
28	532 17 57-65	Rod, Parking Brake	166	817 49 05-10	Screw 5/16-18 x 5/8
29	532 07 16-73	Cap, Parking Brake	167	532 16 55-88	Bracket Support Shift CRD
30	532 16 95-92	Bracket, Mfg. Transaxle	168	532 16 54-92	Bolt Shoulder 5/16-18 x .561
34	532 17 55-78	Shaft, Asm Pedal Foot CRD	169	532 16 55-80	Plate Fastening Lt
35	532 12 01-83	Bearing, Nylon	171	817 49 06-08	Screw Thdrol 3/8-16 x 1/2 Ty-Tt
36	819 21 16-16	Washer 21/32 x 1 x 16 Ga.	172	532 17 02-71	Shaft Asm Shifter Frt CRD
37	532 12 49-63	Pin, Roll 3/16 x 1"	177	532 16 59-32	Keeper Flat Idler 3.06" CRD
38	532 16 59-36	Pulley Flat Composite 3.06"	181	532 18 02-11	Bracket Idler Ground Drive CRD
39	874 76 06-44	Bolt Fin Hex 3/8-16 unc x 2-3/4	182	532 18 26-82	Keeper Belt 2.5" Od V-Idler CRD
40	532 12 49-65	Spacer, Split 395 x 59 Bzp	183	532 18 60-07	Pulley V-Idler 2.50" Od CRD
42	819 13 13-12	Washer 13/32 x 13/16 x 12 Ga.	185	532 17 00-08	Link Shift
43	819 11 10-12	Washer 11/32 x 5/8 x 12 Ga.	186	532 16 56-14	Hub Tapered Round CRD
47	532 12 77-83	Pulley, Idler, V Groove Plasic	187	817 58 05-20	Screw Thdrol 5/16-18 x 1.25
48	532 15 44-07	Bellcrank Clutch Grnd Drv	197	532 16 96-13	Nyliner Snap-In 5/8
49	532 12 32-05	Retainer, Belt Style Spring	199	532 16 96-12	Bolt Shoulder 5/16-18 unc
50	872 11 06-12	Bolt 3/8-16 x 1-1/2 Gr. 5	200	872 14 05-08	Bolt RDHD SQNK 5/16-18 x 1
51	873 68 06-00	Nut, Crownlock 3/8-16 unc	207	532 16 98-45	Washer Nylon Rear
52	873 6805-00	Nut Crownlock 5/16-18	214	532 17 56-09	Shaft Asm. Brake
53	532 19 96-52	Link, Clutch 7.66	215	532 17 56-52	Rod Brake Hydro
55	532 10 57-09	Spring, Return, Clutch	243	532 19 07-36	Bracket Anti-Rotation
56	817 06 06-20	Screw 3/8-16 x 1-1/4	252	819 13 16-16	Washer 13/32 x 1 x 16 Ga.
57	532 17 01-40	V-Belt Kev 112" 0650 CRD	254	817 00 06-16	Screw 3/8-16 x 1 Smgml
62	532 12 35-33	Cover, Pedal	255	532 17 56-08	Brace Shaft Brake Mtg.
63	532 18 03-97	Pulley, Engine	258	532 17 80-62	Clip Retainer
65	810 04 07-00	Washer	259	532 18 02-12	Bracket Pulley IDL Hydro Grd. Dr.
66	532 15 47-78	Keeper, Belt Engine F-Proof	260	532 19 76-07	Bracket Idler Chassis
71	532 16 91-83	Strap, Torque, Lh	261	532 13 14-94	Pulley Idler flat
73	532 16 91-82	Strap, Torque, Rh	262	872 11 06-22	Bolt Rdhd 3/8-16 unc x 2-3/4 Gr. 5
74	532 13 70-57	Spacer, Split	263	817 00 06-12	Screw HXWSH THDROL 3/8-16 x 3/4 Blk
75	532 12 17-49	Washer 25/32 x 1-1/4 x 16 Ga.	266	532 18 20-61	Shield Idler Mower
76	812 00 00-01	Ring, E	279	872 11 06-16	Bolt Rdhd Sqnk 3/8-16 unc x 2
77	532 12 35-83	Key, Square	292	532 40 02-71	Spacer
78	532 12 17-48	Washer 25/32 x 1-5/8 x 16 Ga.	295	532 17 91-14	Pulley Idler Composite
81	532 17 00-06	Asm, Shaft			
82	532 16 57-11	Spring, Torsion			

NOTE: All component dimensions given in U.S. inches
1 inch = 25.4 mm

REPAIR PARTS

TRACTOR- -MODEL NO. CTH150 XP (96061006600), PRODUCT NO. 960 61 00-66
STEERING ASSEMBLY

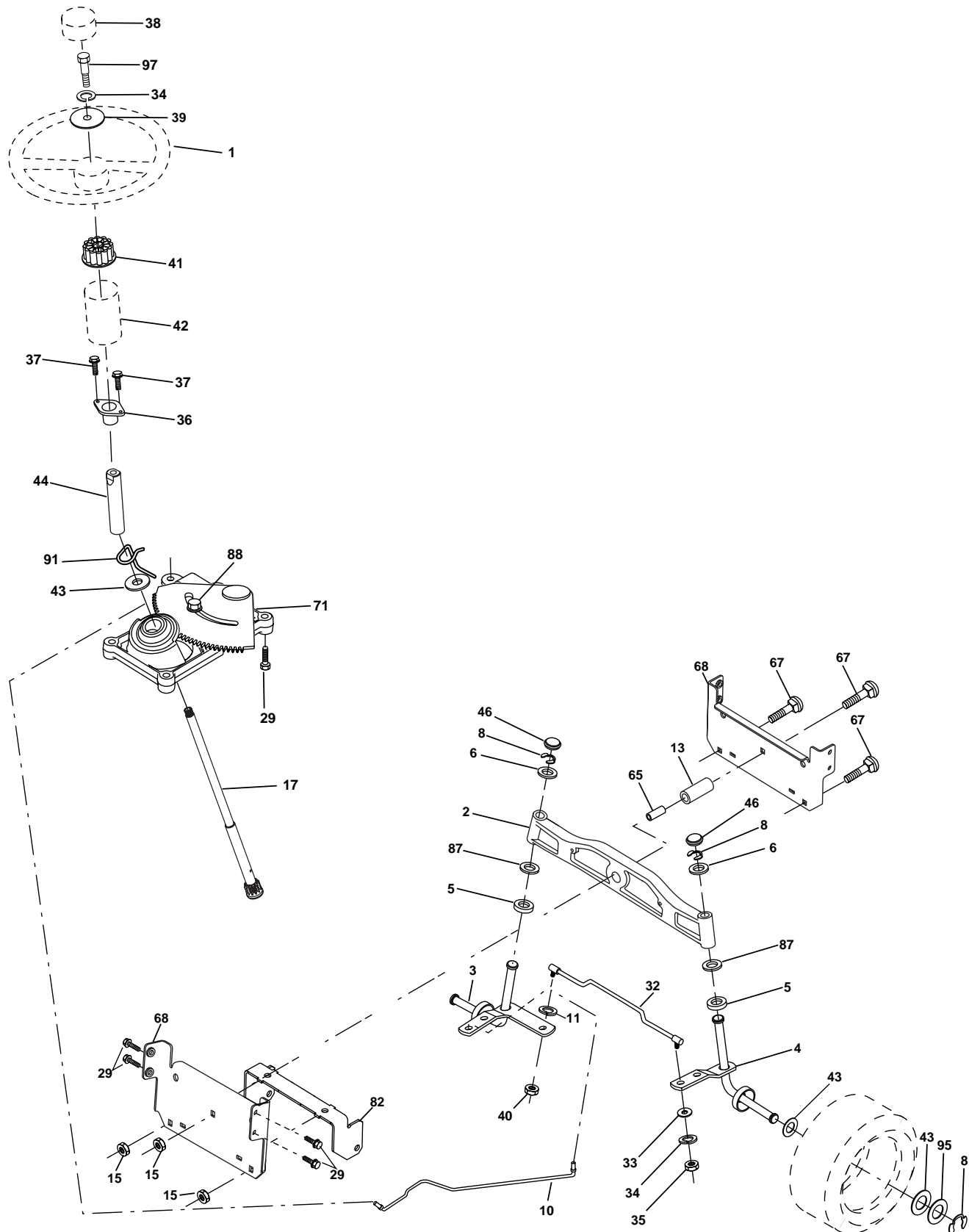

REPAIR PARTS

TRACTOR- -MODEL NO. CTH150 XP (96061006600), PRODUCT NO. 960 61 00-66
STEERING ASSEMBLY

KEY NO.	PART NO.	DESCRIPTION
1	532 19 36-51	Steering Wheel
2	532 18 47-06	Axle Asm Cast Iron Lt
3	532 16 98-40	Spindle Assembly, L.H.
4	532 16 98-39	Spindle Assembly, R.H.
5	532 12 49-31	Bearing, Race, Thrust, Hardened
6	532 12 17-48	Washer 25/32 x 1-5/8 x 16 Ga.
8	812 00 00-29	Ring, Klip
10	532 17 51-21	Link, Drag
11	810 04 06-00	Washer, Lock
13	532 13 65-18	Spacer Brg Axle Front
15	532 14 52-12	Nut Hex Flange Lock
17	532 19 07-53	Shaft, Steering
29	817 00 06-12	Screw 3/8-16 x 3/4
32	532 17 18-88	Rod, Tie
33	819 11 12-16	Washer 11/32 x 3/4 x 16 Ga.
34	810 04 05-00	Washer Lock Hvy Hlcl Spr 5/16
35	873 54 05-00	Crownlock Nut 5/16-24 unf 3847
36	532 15 50-99	Bushing, Steering
37	532 15 29-27	Screw TT #10-32 x 5 x 3/8 Flange
38	532 19 36-52	Cap Wheel Steering
39	819 11 38-12	Washer 11/32 ID x 2- 3/8 OD x 12 Ga.
40	876 54 06-00	Nut Lock 3/8-24
41	532 18 67-37	Adaptor, Steering Wheel
42	532 16 96-34	Boot, Steering Dash P/L Mtl
43	532 12 17-49	Washer 25/32 x 1-1/4 x 16 Ga.
44	532 19 07-52	Extension Steering Shaft
46	532 12 12-32	Cap, Spindle
65	532 16 03-67	Spacer Brace Axle
67	872 11 06-18	Bolt Rdhd Sqnk 3/8-16 x 2-1/4
68	532 16 98-27	Brace Axle
71	532 17 51-46	Steering Asm.
82	532 19 99-78	Bracket Susp Chassis Front
87	532 17 39-66	Washer Flat .781 x 1 1/2 x .14
88	532 17 51-18	Bolt Shoulder 7/16-20 unc
91	532 17 55-53	Clip Steering
95	532 18 89-67	Washer
97	874 78 05-64	Bolt 5/16-18 unc x 4" L. Gr. 5

NOTE: All component dimensions given in U.S. inches.
1 inch = 25.4 mm.

REPAIR PARTS

TRACTOR- -MODEL NO. CTH150 XP (96061006600), PRODUCT NO. 960 61 00-66
ENGINE

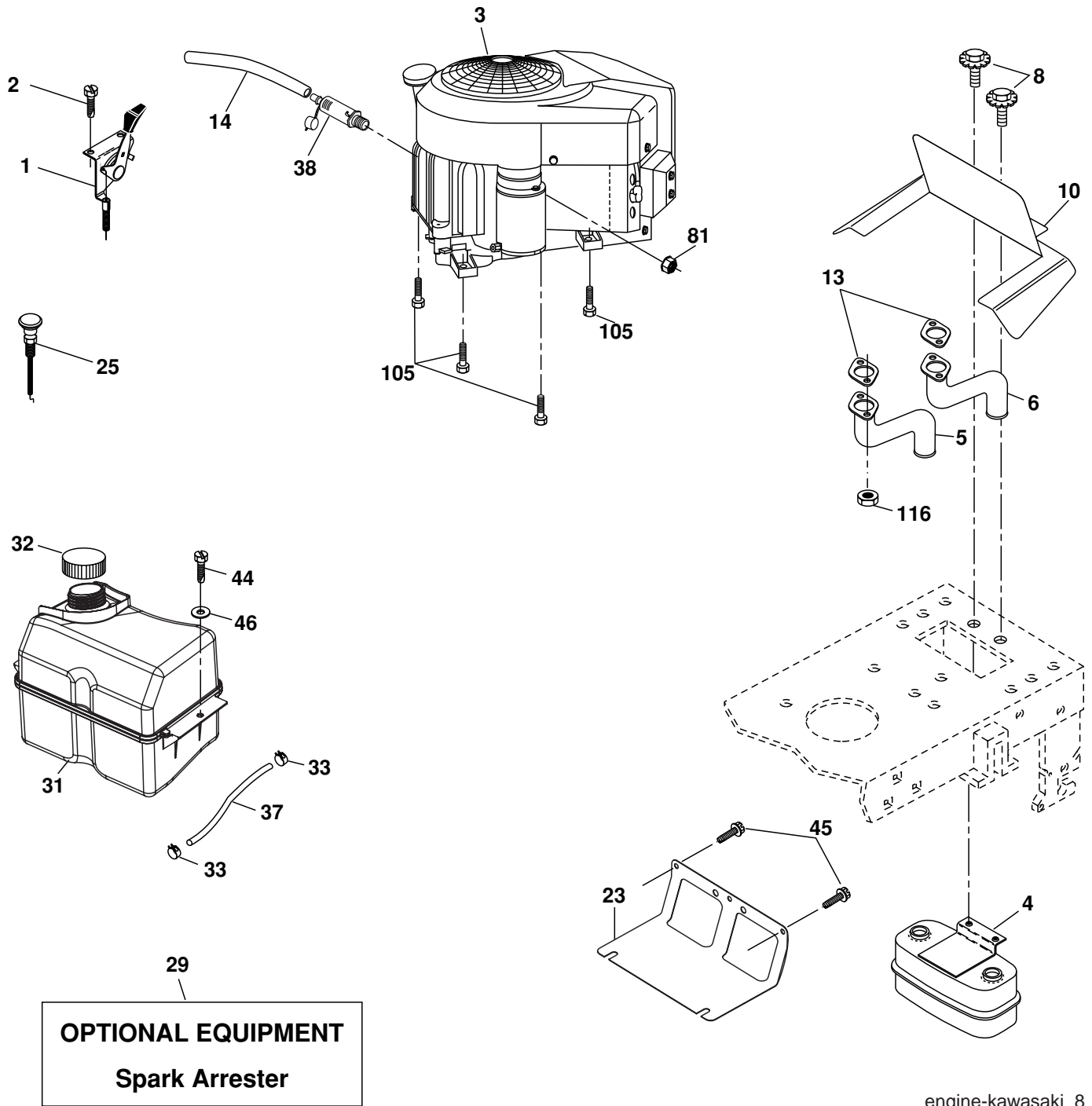

REPAIR PARTS

TRACTOR- -MODEL NO. CTH150 XP (96061006600), PRODUCT NO. 960 61 00-66
ENGINE

KEY NO.	PART NO.	DESCRIPTION
1	532 17 08-03	Control Throt /Ch Flag
2	817 72 04-08	Screw Hex Thd Cut 1/4-20 x 1/2
3	-----	Engine KAWA FH430V (Order Parts from Engine Manufacturer)
4	532 14 97-23	Muffler Exhaust
5	532 18 14-42	Exhaust Tube LH
6	532 18 14-44	Exhaust Tube RH
8	532 17 18-77	Bolt 5/16-18 x 3/4
10	532 14 66-29	Shield Heat Muffler
13	-----	Gasket (Order Parts from Engine Manufacturer)
14	532 14 84-56	Tube Drain Oil Easy
23	532 16 98-37	Shield Browning/Debris Guard
25	532 19 18-12	Control Cable
29	532 13 71-80	Arrestor Spark
31	532 18 55-34	Tank Fuel
32	532 14 05-27	Cap Asm Fule Top Vent N/Lany
33	532 12 34-87	Clamp Hose Blk
37	532 13 70-40	Line Fuel 20"
38	-----	Plug Drain Oil Easy (Order Parts from Engine Manufacturer)
44	817 67 04-12	Screw Hexwsh Thdrol 1/4-20 x 3/4
45	817 00 06-12	Screw Hexwsh Thdr 3/8-16 x 3/4
46	819 09 14-16	Washer 9/32 x 7/8 x 16ga
81	873 51 04-00	Nut Keps 1/4-20 unc
105	817 12 06-16	Screw 3/8-16 x 1
116	532 18 43-62	Nut Hex Flange Toplock M8-1.25

NOTE: All component dimensions given in U.S. inches.
1 inch = 25.4 mm

REPAIR PARTS

TRACTOR- -MODEL NO. CTH150 XP (96061006600), PRODUCT NO. 960 61 00-66
MOWER LIFT

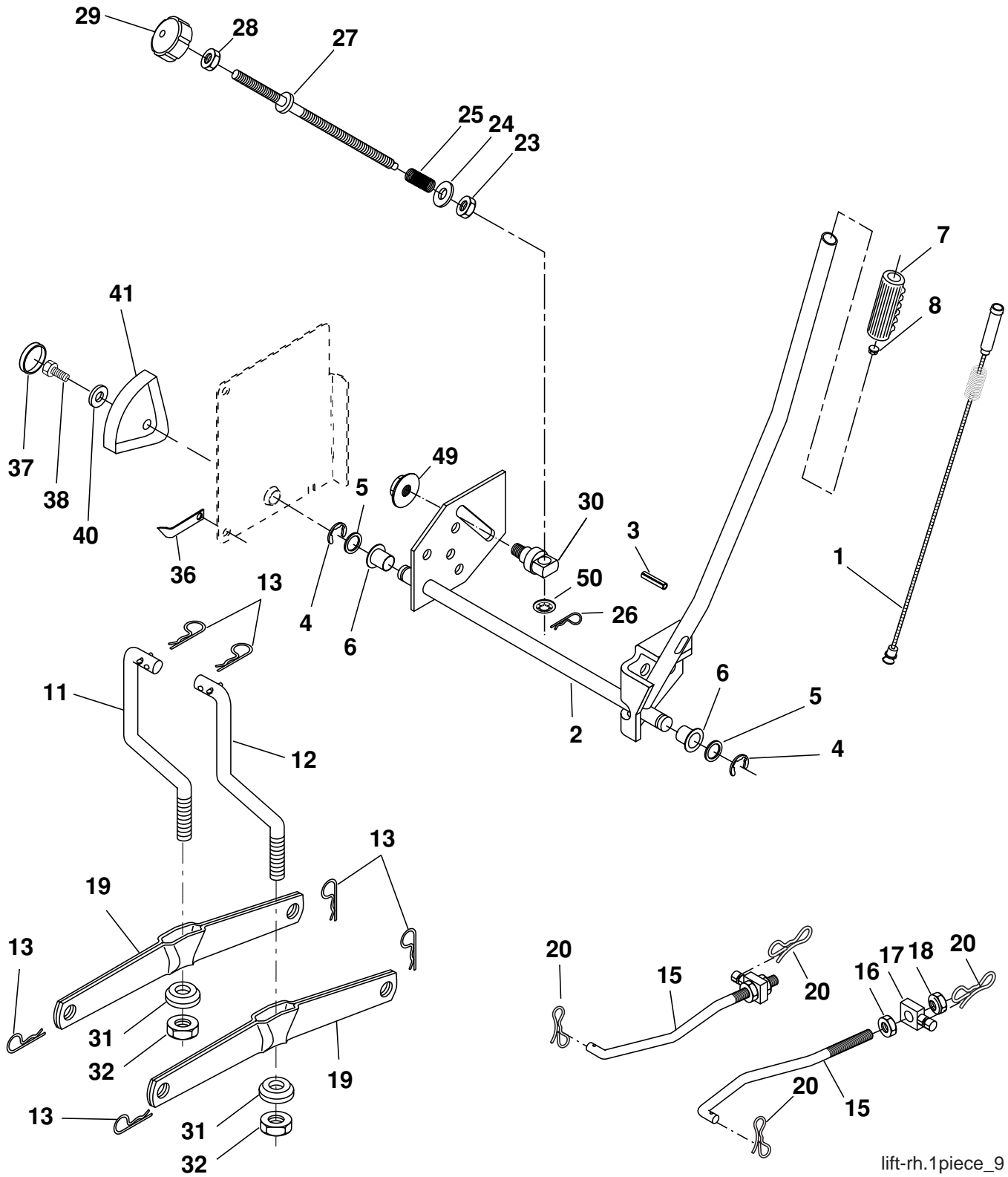

REPAIR PARTS

TRACTOR- -MODEL NO. CTH150 XP (96061006600), PRODUCT NO. 960 61 00-66
MOWER LIFT

KEY NO.	PART NO.	DESCRIPTION
1	532 15 94-60	Washer Asm Inner Spring W/Plunger
2	532 15 94-71	Shaft Asm. Lift
3	532 10 57-67	Pin Groove
4	812 00 00-02	E Ring #5133-62
5	819 21 16-21	Washer 21/32 x 1 x 21 Ga.
6	532 12 01-83	Bearing Nylon
7	532 12 56-31	Grip Handle
8	532 12 45-26	Button Plunger Black
11	532 16 58-29	Link Lift L.H.
12	532 16 58-31	Link Lift R.H.
13	532 12 46-70	Retainer Spring
15	532 17 32-88	Link Front
16	873 35 08-00	Nut Jam Hex 1/2-13 unc
17	532 17 56-89	Trunnion
18	873 80 08-00	Nut Lock W/Wsh 1/2-13 unc
19	532 13 98-68	Arm Suspension Mower
20	532 19 42-09	Pin Cotter 7/16 Bow Tie Lock
23	532 11 08-07	Nut Special
24	819 13 10-16	Washer 13/32 x 5/8 x 16 Ga.
25	532 12 48-74	Spring 2-1/8
26	532 16 94-84	Retainer Clip
27	532 12 69-71	Rod Adj Lift Zinc
28	873 35 06-00	Nut Hex Jam 3/8-16 unc
29	532 13 80-57	Knob Inf 3/8-16 unc
30	532 15 02-33	Trunnion Infin Height
31	532 16 98-65	Bearing, Pvt. Lift.
32	873 54 06-00	Nut Crownlock 3/8-24
36	532 15 50-97	Pointer Height Indicator
37	532 12 39-35	Plug Hole Blk
38	817 06 05-16	Screw 5/16-18 x 1
40	819 11 24-10	Washer 11/32 x 1-1/2 x 10 Ga.
41	532 12 39-34	Scale Ind Height Blk
49	532 14 52-12	Nut Hex flange lock
50	532 11 04-52	Nut Push Phos &Oil

NOTE: All component dimensions given in U.S. inches.
1 inch = 25.4 mm

REPAIR PARTS

TRACTOR- -MODEL NO. CTH150 XP (96061006600), PRODUCT NO. 960 61 00-66
MOWER

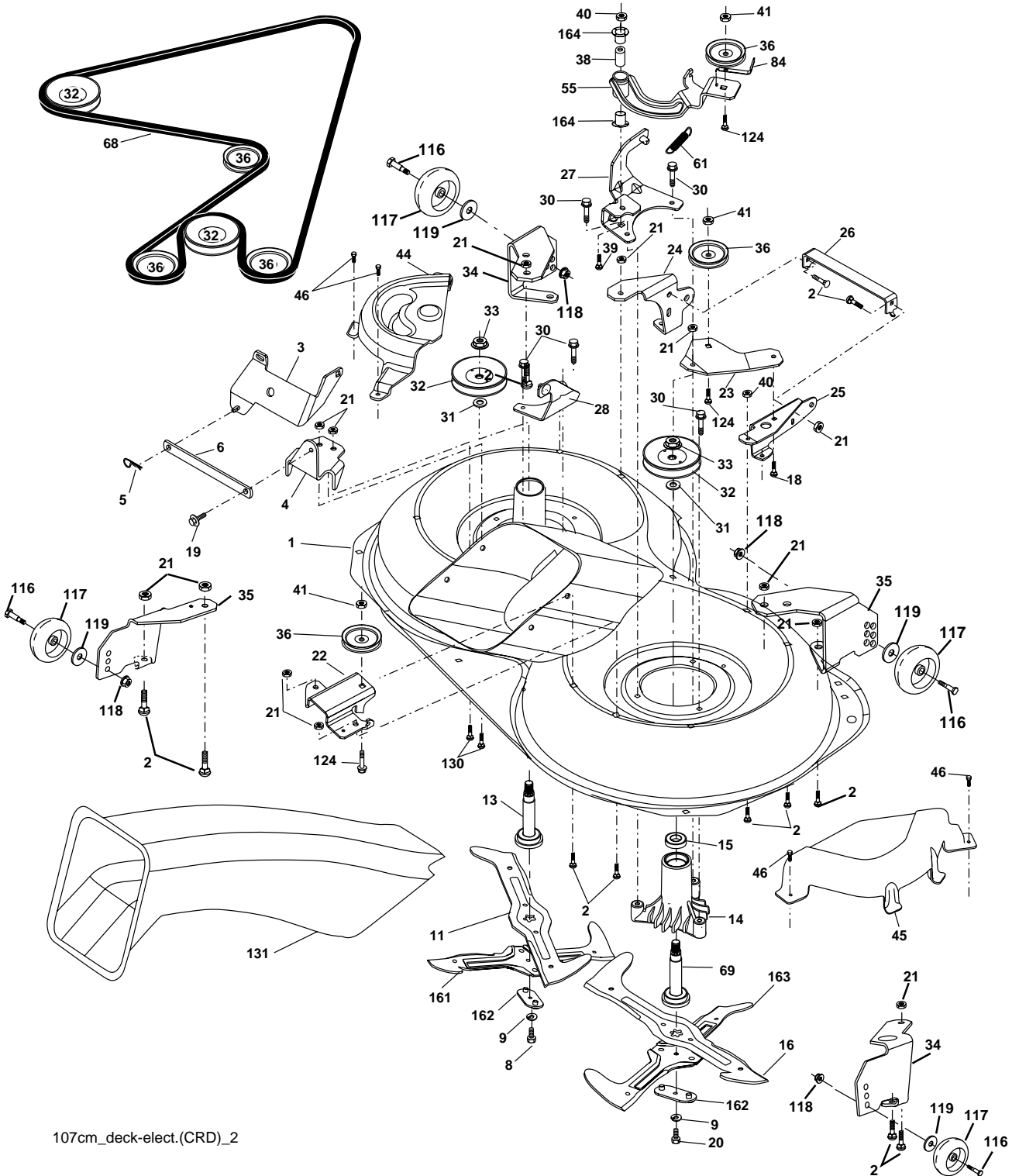

107cm_deck-elect.(CRD)_2

REPAIR PARTS

**TRACTOR- -MODEL NO. CTH150 XP (96061006600), PRODUCT NO. 960 61 00-66
MOWER**

KEY NO.	PART NO.	DESCRIPTION	KEY NO.	PART NO.	DESCRIPTION
1	532 16 91-60	Housing Asm. Mower	38	532 16 98-51	Spacer Hub Arm Idler
2	872 14 05-06	Bolt Rdhd Sqnk 5/16-18 unc x 3/4	39	872 11 06-22	Bolt RhHd 3/8-16 unc x 2-3/4 Gr. 5
3	532 16 55-69	Bracket Asm. S-Bar Chass	40	873 68 06-00	Nut Crownlock 3/8-16 unc
4	532 16 91-67	Bracket Bar Sway Deck	41	873 90 06-00	Nut Flangelock 3/8-16 unc
5	532 12 46-70	Retainer Spring	44	532 17 55-38	Cover Mandrel Lh
6	532 16 55-57	Bar Sway	45	532 17 55-39	Cover Mandrel Rh
8	532 18 17-12	Bolt 3/8-24 x 1.25 Gr. 8 Patched	46	532 13 77-29	Screw Thd Roll 1/4-20 x 5/8
9	810 03 06-00	Washer Lock Hvy 3/8 Unplated	55	532 16 98-49	Arm Idler
11	532 18 05-83	Blade 3-1 Lh	61	532 17 51-59	Spring Tension Belt
13	532 13 76-45	Shaft Asm. W/Lower Bearing	68	532 16 91-78	Hex-Belt Mower
14	532 12 87-74	Housing Mandrel Vented (Machd)	69	532 16 54-82	Shaft Asm W/Lwr Brg Rh Thd CRD
15	532 11 04-85	Bearing Ball Mandrel	84	532 15 60-85	Keeper Belt Idler
16	532 18 05-84	Blade 3-1 Rh	116	532 18 42-19	Bolt Shoulder
18	872 11 06-06	Bolt 3/8-16 x 3/4	117	532 17 48-73	Wheel Gauge
19	532 13 28-27	Bolt Shoulder 5/16-18 Thd Form	118	873 93 06-00	Nut Centerlock 3/8-16 unc
20	532 18 17-13	Bolt 3/8-24 x 1.25 Gr. 8 Ptch Lhthd	119	819 12 14-14	Washer 3/8 x 7/8 x 14 Ga.
21	873 68 05-00	Nut Crown Lock 5/16-18	124	872 11 06-12	Bolt Carr Sh 3/8-16 x 1-1/2 Gr. 5
22	532 16 91-65	Bracket Idler Sprt RR	130	872 11 05-06	Bolt Rdhdsqnk 5/16-18 unc x 3/4
23	532 16 91-66	Bracket Idler Sprt RF	131	532 16 56-61	Chute Bagger CRD 92cm
24	532 16 91-70	Bracket Suspension LF	161	532 18 04-24	Blade Cross LH 107
25	532 40 01-05	Bracket Suspension RF	162	532 18 08-78	Adapter Weldment Blade 107
26	532 40 01-10	Brace Support Susp Frt CRD	163	532 18 04-25	Blade Cross RH 107
27	532 16 91-72	Bracket Asm. Susp RR	164	532 12 49-37	Bearing
28	532 16 91-68	Bracket Asm. Susp LR	--	532 18 18-57	Mandrel Asm Service
30	532 17 39-84	Screw Thd Rolling Dod.PT Hex	--	532 18 18-58	Mandrel Asm CRD Lh Threads VC
31	532 18 76-90	Washer Spacer	--	532 18 17-70	Replacement Mower Complete (Std. Deck-Order separately gauge wheels components key nos. 116-119)
32	532 17 57-07	Mandrel Pulleys			
33	532 40 02-34	Nut Flg Top Lock			
34	532 40 01-03	Bracket Gauge Wheel Lf/Rr			
35	532 40 01-04	Bracket Gauge Wheel Rf/Lr			
36	532 14 67-63	Pulley Idler V-Groove Dim 4.25			

NOTE: All component dimensions given in U.S. inches
1 inch = 25.4 mm

REPAIR PARTS

TRACTOR- -MODEL NO. CTH150 XP (96061006600), PRODUCT NO. 960 61 00-66
BAGGER

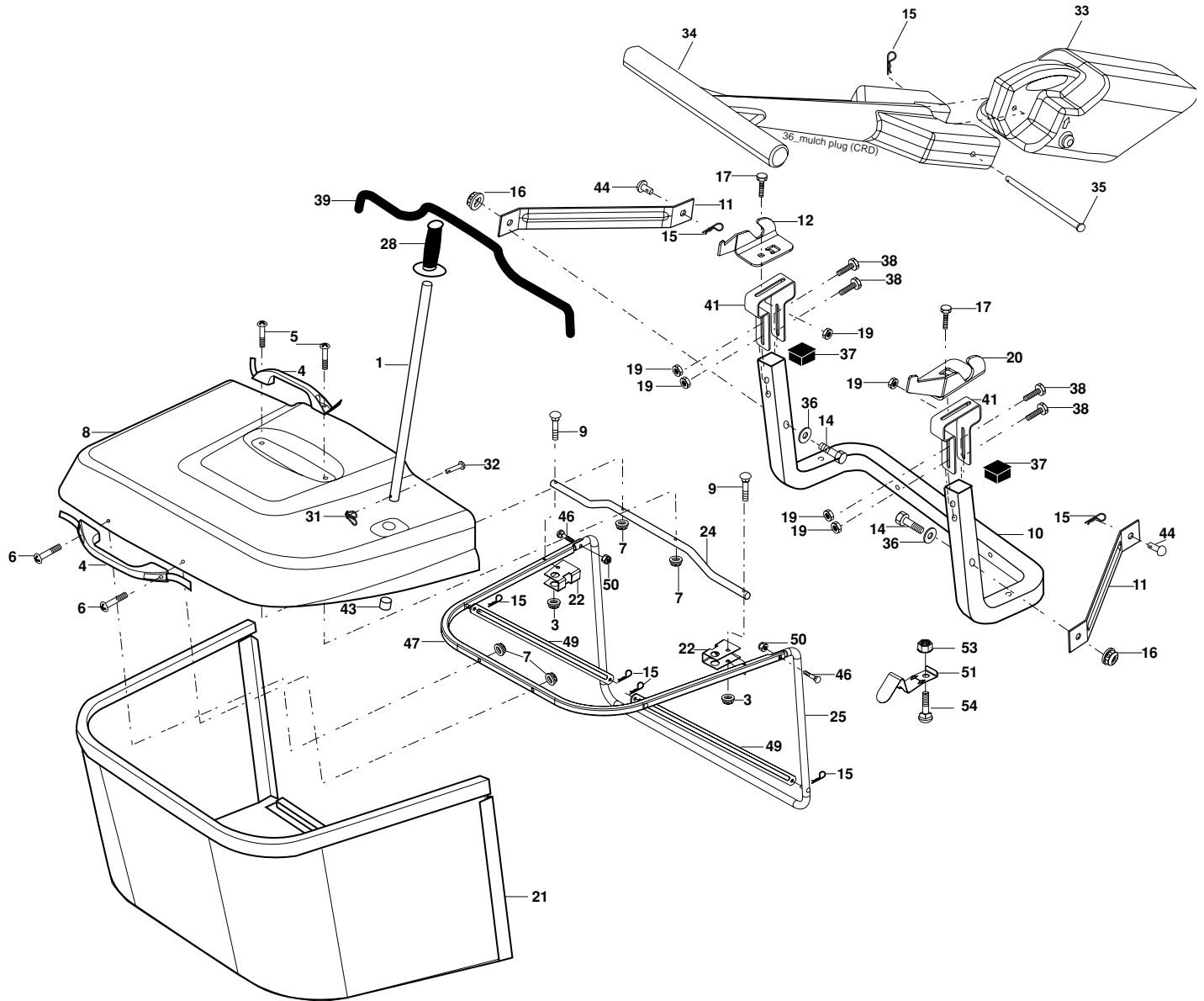

Bagger Asy (CRD)_11

REPAIR PARTS

TRACTOR- -MODEL NO. CTH150 XP (96061006600), PRODUCT NO. 960 61 00-66
BAGGER

KEY NO.	PART NO.	DESCRIPTION
1	532 16 52-49	Tube Handle Bagger CRD
3	532 12 39-76	Nut Lock 1/4 Lge Flg Gr. 5 Zinc
4	532 16 99-16	Handle Bagger w/Lvrs Blk CRD
5	874 98 10-24	Screw Pan Head #10-24 x 1.50 Blk
6	874 98 10-32	Screw Pan Hd
7	873 40 10-00	Nut Wiz Lock Hex Serr/Hd 10-24
8	532 18 10-95	Cover Bagger CRD MS422
9	872 14 04-18	Bolt Carriage 1/4-20 x 2.25d x Gr. 5
10	532 18 12-82	Tube Support Bagger CRD
11	532 16 57-19	Bracket Support Upper Bag CRD
12	532 18 88-48	Bracket Pivotn Lh
14	874 52 06-36	Bolt Carr.
16	873 90 06-00	Nut Lock Flg. 3/8-16 unc
15	532 12 46-70	Retainer Spring
17	872 14 05-06	Bolt Rdhd Sht Sqnk 5/16 -18 unc x 3/4
19	873 90 05-00	Nut Lock Hexflange 5/16-18
20	532 18 88-47	Bracket Pivot Rh
21	532 19 38-38	Bag Asm CRD
22	532 16 57-81	Bracket Side Bagger CRD
24	532 16 57-83	Tube Pivot Bagger CRD
25	532 19 37-05	Tube Front Bagger CRD
28	532 16 57-87	Grip Handle Black
31	532 16 94-84	Retainer Clip
32	532 12 68-75	Rivet Rd Hd Drilled 3/8 Dia
33	532 16 93-80	Plug Mulcher
34	532 16 55-70	Handle Mulcher 92/107 CRD
35	532 16 55-72	Pin Mulcher 92/107 CRD
36	819 13 20-12	Washer 13/32 x 1-1/4 x 12 Ga.
37	532 17 54-01	Plug Support Bagger CRD
38	872 01 05-20	Bolt 5/16-18 x 2-1/2
39	532 18 09-85	Seal 37"
41	532 16 96-83	Bracket Vert Adj Bagger CRD
43	532 17 40-83	Plug Tubing
44	532 19 33-12	Pin Clevis
46	872 11 05-10	Bolt Carr. 5/16-18 x 1-1/4 Gr.5
47	532 19 37-04	Tube Upper Bagger
49	532 19 33-05	Bar Spreader
50	873 80 05-00	Nut Lock Thx w/Ins. 5/16-18 unc
51	532 19 99-03	Latch Spring Bagger
53	873 51 04-00	Nut Keps Hex 1/4-20 unc
54	872 14 04-06	Bolt RDHD SQNK 1/4-20 x 3/4 Gr.5

NOTE: All component dimensions given in U.S. inches
1 inch = 25.4 mm