

LT1597

Spare parts

Ersatzteile

Pièces détachées

Reserve onderdelen

Repuestos

Reservdelar

TRACTOR -- MODEL NUMBER LT1597 (96011022000), PRODUCT NO. 960 11 02-20 SCHEMATIC

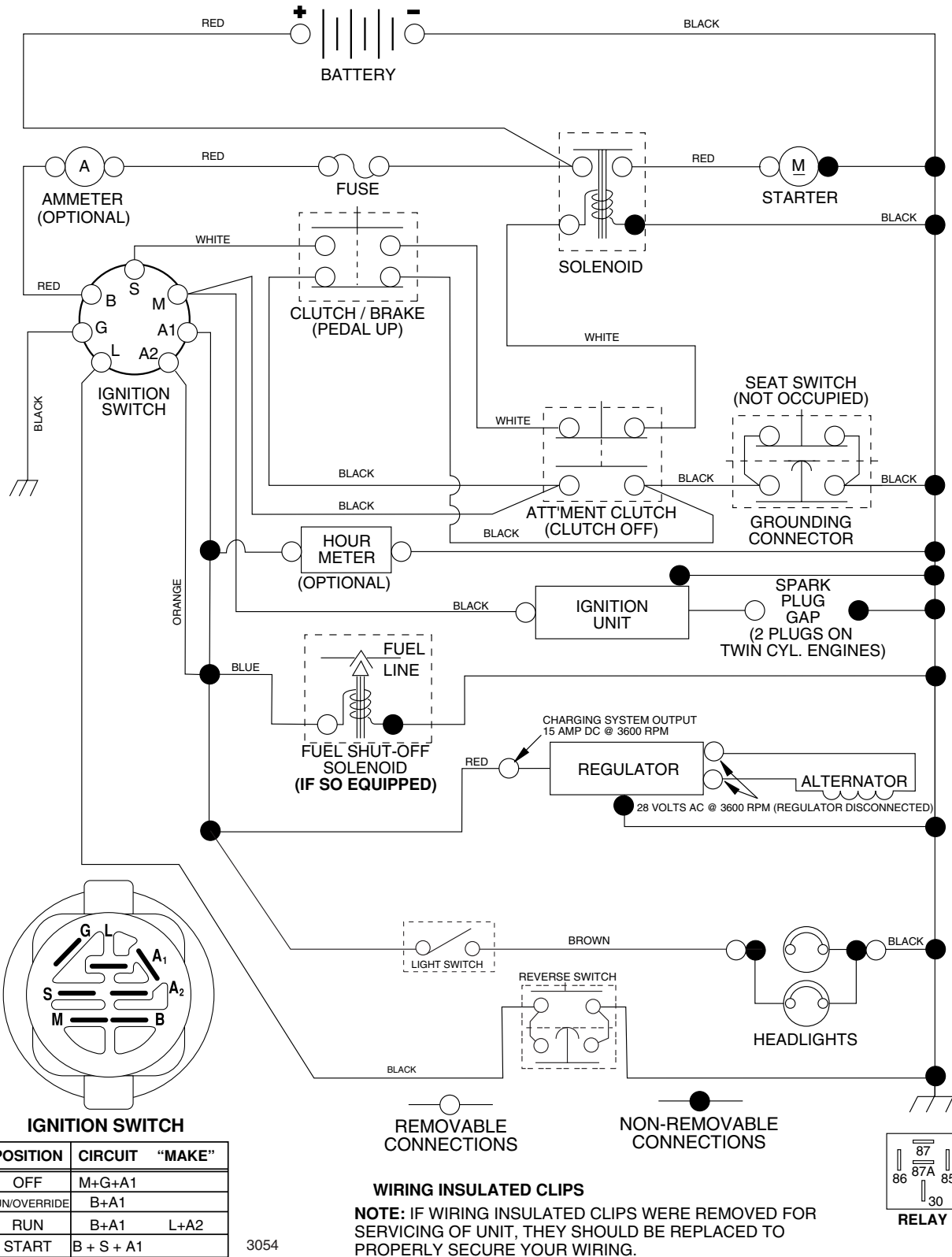

IGNITION SWITCH

POSITION	CIRCUIT	"MAKE"
OFF	M+G+A1	
RUN/OVERRIDE	B+A1	
RUN	B+A1	L+A2
START	B+S+A1	

3054

REPAIR PARTS

TRACTOR -- MODEL NUMBER LT1597 (96011022000), PRODUCT NO. 960 11 02-20
ELECTRICAL

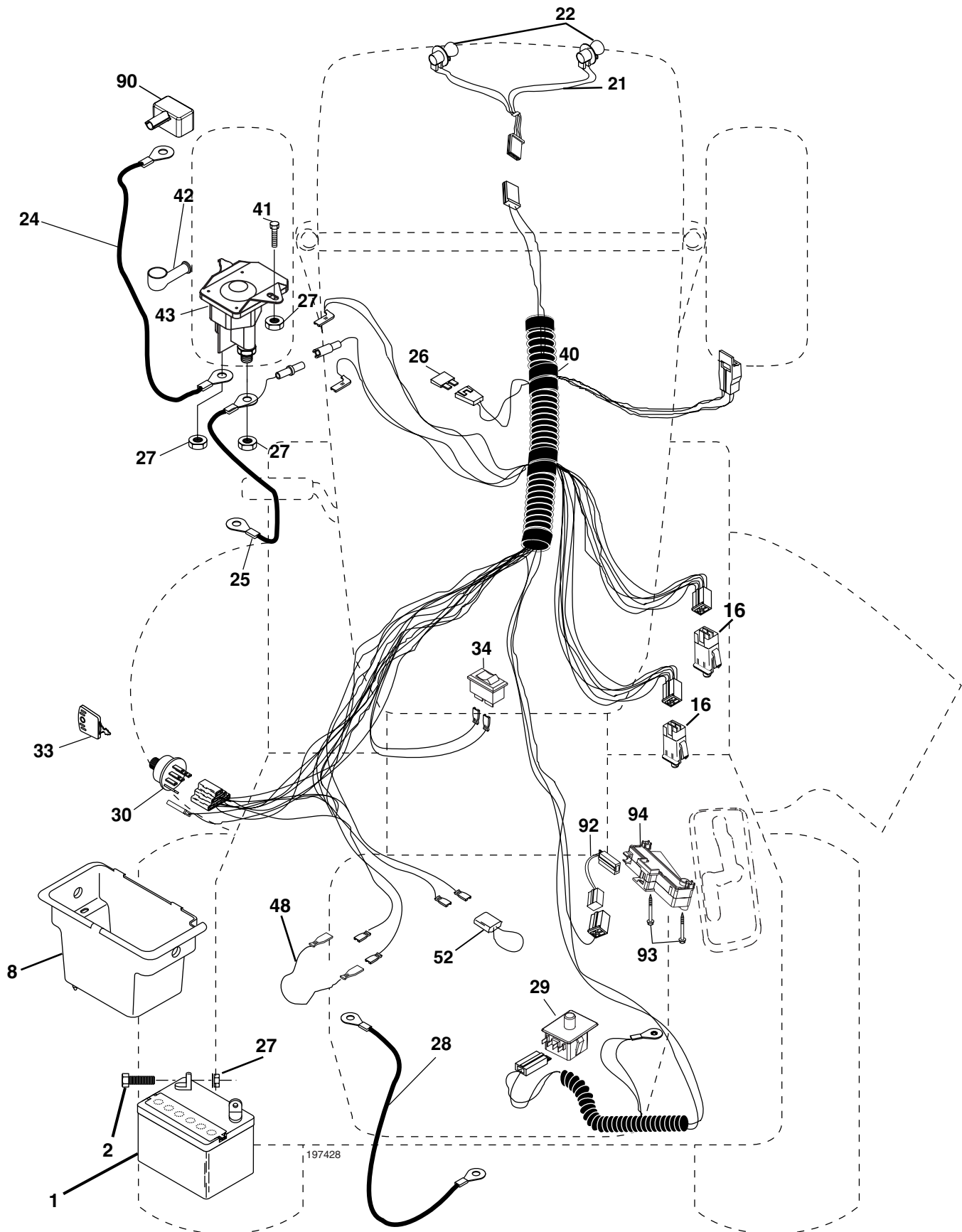

197428

REPAIR PARTS

TRACTOR - - MODEL NUMBER LT1597 (96011022000), PRODUCT NO. 960 11 02-20
ELECTRICAL

KEY NO.	PART NO.	DESCRIPTION
1	532 14 49-27	Battery
2	874 76 04-12	Bolt Hex Hd 1/4-20 unc x 3/4
8	532 17 66-89	Case Battery
16	532 17 61-38	Switch Interlock Push-In
21	532 17 56-88	Harness Asm Light W/4152j
22	532 00 41-52	Bulb Light #1156
24	532 12 47-80	Cable Battery 6 Ga. 11"red
25	532 14 61-47	Cable Battery
26	532 17 51-58	Fuse
27	873 51 04-00	Nut Keps Hex 1/4-20 Unc
28	532 12 47-73	Cable Ground 6 Ga 12"black
29	532 19 27-49	Switch Seat
30	532 19 33-50	Switch Ign
33	532 14 04-01	Key Ign
34	532 11 07-12	Switch Light
40	532 19 74-28	Harness Ign
41	871 11 04-08	Bolt Blk Fin Hex 1/4-20
42	532 13 15-63	Cover Terminal Red
43	532 19 25-07	Solenoid
48	532 14 08-44	Adapter Ammeter
52	532 14 19-40	Protection Wire Loop
90	532 18 04-49	Cover Terminal Battery
92	532 19 66-15	Harness Pigtail
93	532 19 25-40	Screw Plastite 10-14 x 2.0
94	532 19 18-34	Module Reverse

NOTE: All component dimensions given in U. S.
inches 1 inch = 25.4 mm.

REPAIR PARTS

TRACTOR -- MODEL NUMBER LT1597 (96011022000), PRODUCT NO. 960 11 02-20
CHASSIS

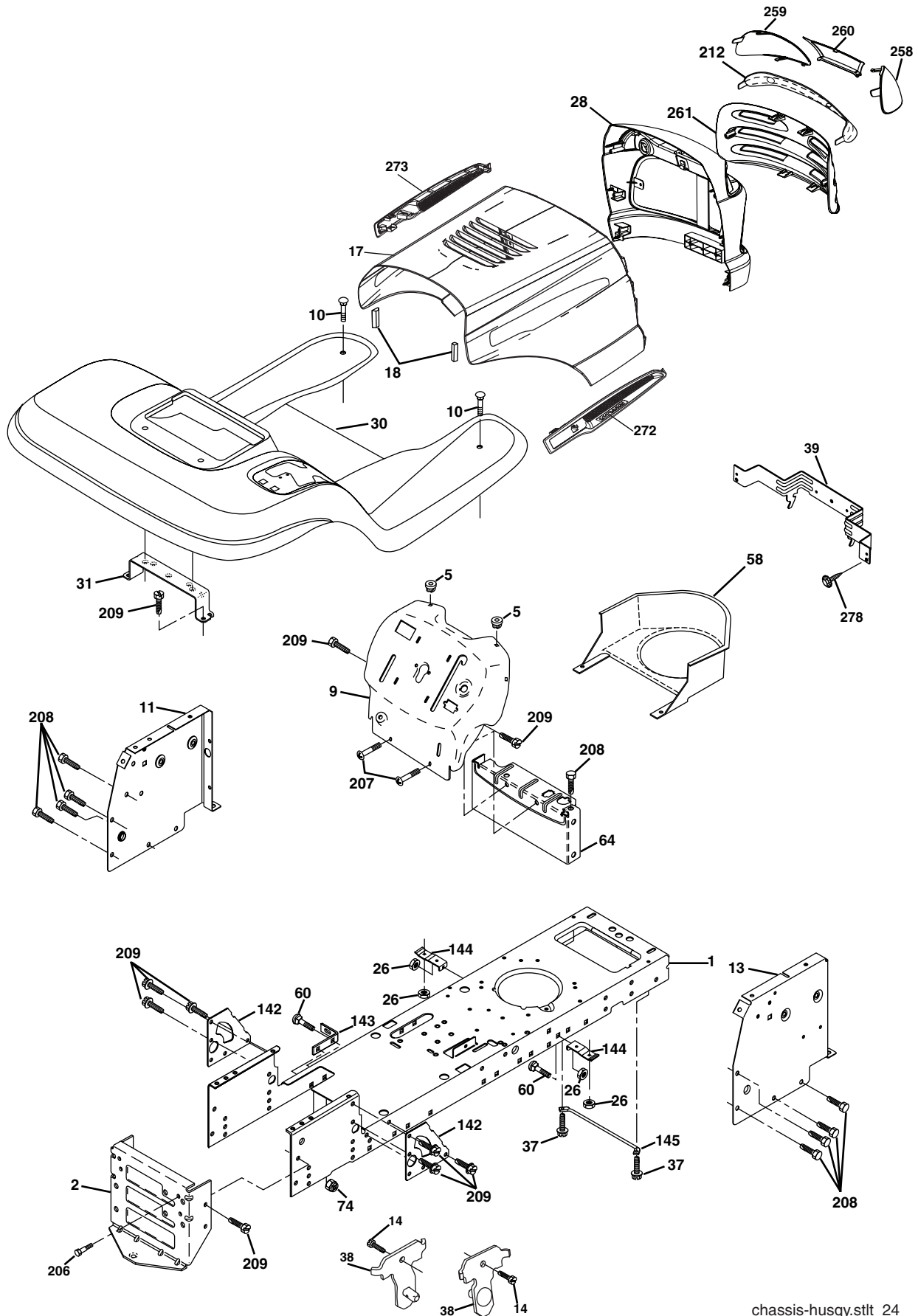

REPAIR PARTS

TRACTOR - - MODEL NUMBER LT1597 (96011022000), PRODUCT NO. 960 11 02-20
CHASSIS

KEY NO.	PART NO.	DESCRIPTION
1	532 17 46-19	Chassis
2	532 17 65-54	Drawbar
5	532 15 52-72	Bumper, Hood/Dash
9	532 19 39-37	Dash
10	872 14 06-08	Bolt, Carriage 3/8-16 x 1
11	532 17 49-96	Panel Dash LH
13	532 18 17-19	Panel Silscr Dash RH
14	817 49 06-08	Screw Thdrol 3/8-16 x 1/2
17	532 18 88-93	Hood
18	532 18 49-21	Bumper Hood
26	873 80 06-00	Nut Lock Hex w/Ins 3/8-16 unc
28	532 18 35-38	Grille/Lens Asm. (Includes key Nos. 212, 258, and, 261)
30	532 19 39-38	Fender
31	532 13 99-76	Bracket Fender
37	817 49 05-08	Screw Thdrol 5/16-18 x 1/2 TYT
38	532 17 57-10	Bracket Asm. Pivot Mower Rear
39	532 17 47-14	Bracket Pivot Laser
58	532 18 71-54	Duct Air
60	872 14 06-06	Bolt RDHD SQNK 3/8-16 unc x 3/4
64	532 15 47-98	Dash Lower
74	873 68 06-00	Nut Crownlock 3/8-16 unc
142	532 17 57-02	Plate Reinforcement
143	532 18 66-89	Bracket Swaybar Chassis
144	532 17 55-82	Bracket Footrest
145	532 15 65-24	Rod Pivot Chassis/Hood
206	532 17 01-65	Bolt Shoulder 5/16-18
207	817 67 05-08	Screw 5/16-18 x 1/2
208	817 67 06-08	Screw Thdrol 3/8-16 x 1/2
209	817 00 06-12	Screw Hex Wsh Thdrol 3/8-16
212	532 18 35-48	Insert Lens Reflective
258	532 18 52-14	Lens RH
259	532 18 52-13	Lens LH
260	532 18 52-16	Cover Lens
261	532 18 52-12	Insert Grille
272	532 18 88-96	Vent Hood RH
273	532 18 88-95	Vent Hood LH
278	532 19 16-11	Screw 10 x 3/4 Single Lead-Hex
- - -	532 00 54-79	Plug Button Blk 359 Dia Choke
- - -	532 18 78-01	Plug Dome Plastic

NOTE: All component dimensions given in U.S. inches
1 inch = 25.4 mm.

REPAIR PARTS

TRACTOR -- MODEL NUMBER LT1597 (96011022000), PRODUCT NO. 960 11 02-20
DRIVE

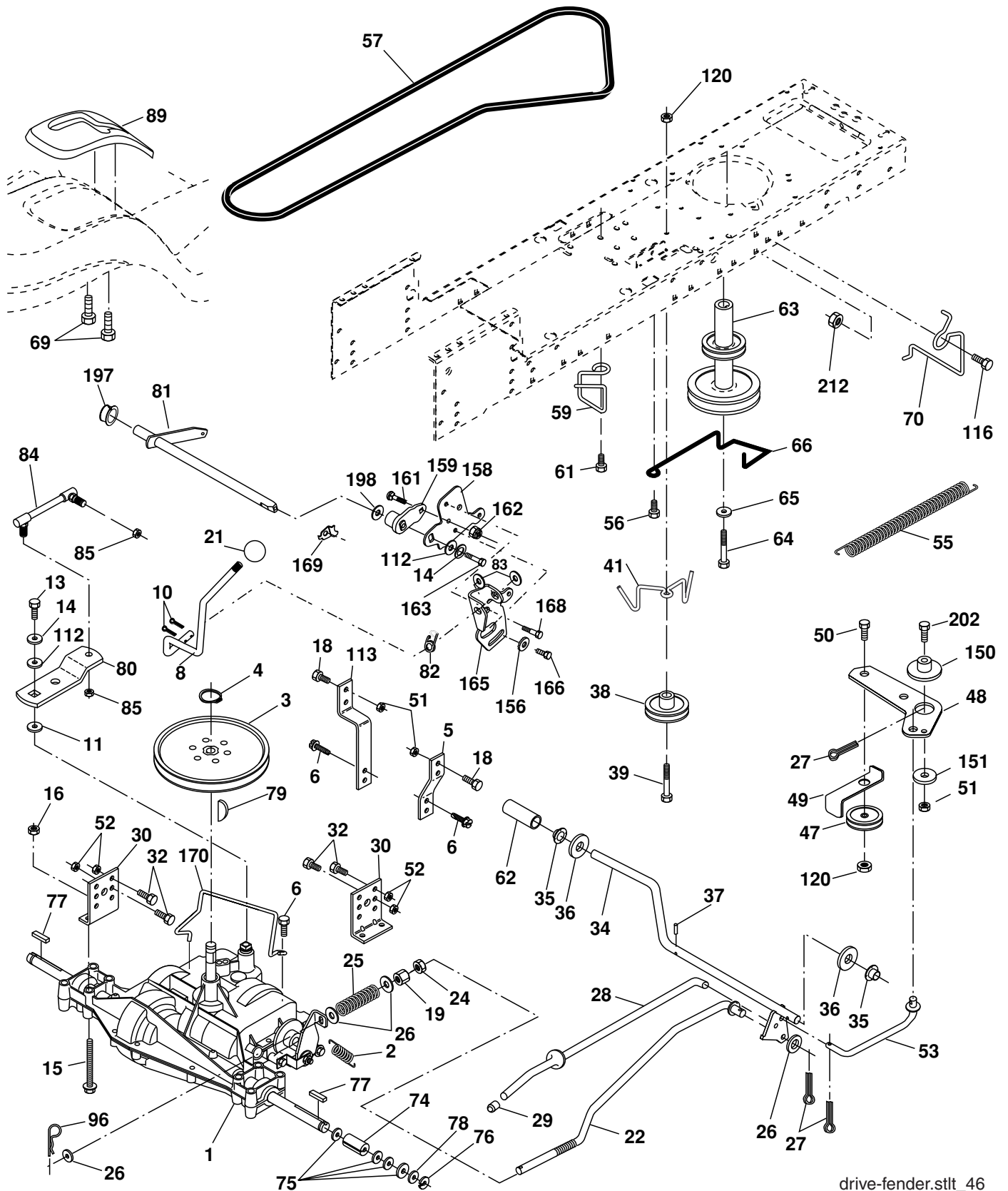

REPAIR PARTS

TRACTOR - - MODEL NUMBER LT1597 (96011022000), PRODUCT NO. 960 11 02-20
DRIVE

KEY NO.	PART NO.	DESCRIPTION	KEY NO.	PART NO.	DESCRIPTION
1	-----	Transaxle, Peerless 206-545C (Order parts from transaxle manufacturer)	62	532 12 48-72	Cover Pedal Blk Round
2	532 14 66-82	Spring Return Brake T/a Zinc	63	532 17 54-10	Engine Pulley
3	532 12 36-66	Pulley Transaxle 18" tires	64	532 17 39-37	Bolt Hex 7/16-20 x 4 x Gr. 5-1.5 THR
4	812 00 00-28	Ring Retainer # 5100-62	65	810 04 07-00	Washer Lock Hvy Hlcl Spr 7/16
5	532 12 15-20	Strap Torque 30 Degrees	66	532 15 47-78	Keeper Belt Engine Foolproof
6	817 06 05-12	Screw 5/16-18 x 3/4	69	532 14 24-32	Screw Hex Wsh Hi-Lo 1/4-1/2 unc
8	532 19 25-02	Rod Shifter Fender	70	532 13 46-83	Guide Belt Mower Drive RH
10	876 02 04-16	Pin Cotter 1/8 x 1 Cad	74	532 13 70-57	Spacer Axle
11	532 10 57-01	Washer Plate Shf 388 Sq Hole	75	532 12 17-49	Washer 25/32 x 1 1/4 x 16 Ga.
13	874 55 04-12	Bolt 1/4-28 unf Gr. 8 W/Patch	76	812 00 00-01	E-ring #5133-75
14	810 04 04-00	Washer Lock Hvy Helical 1/4	77	532 12 35-83	Key Square 2 0 x 1845/ 1865
15	874 49 05-44	Bolt Hex FLGHD 5/16-18 Gr. 5	78	532 12 17-48	Washer 25/32 x 1-5/8 x 16 Ga.
16	873 80 05-00	Nut Lock	79	532 12 50-96	Key Woodruff
18	874 78 06-16	Bolt, Fin Hex 3/8-16 unc x 1 Gr. 5	80	532 13 14-86	Arm Shift
19	873 80 06-00	Nut Lock 3/8-16 Unc	81	532 16 55-94	Shaft Asm Cross Tapered 20"t
21	532 12 12-74	Knob	82	532 16 57-11	Spring Torsion T/a
22	532 13 08-04	Rod Brake	83	819 17 12-16	Washer 17/32 x 3/4 x 16 Ga.
24	873 35 06-00	Nut Hex Jam 3/8-16 unc	84	532 16 62-28	Link Transaxle
25	532 10 68-88	Spring Rod Brake 2 00 Zinc	85	532 15 03-60	Nut Lock Center 1/4 - 28 FNTHD
26	819 13 13-16	Washer 13/32 x 13/16 x 16 Ga.	89	532 19 57-20	Console Shift
27	876 02 04-12	Pin Cotter 1/8 x 3/4 Cad	96	532 12 47-88	Retainer Spring
28	532 17 57-65	Rod Brake Parking	112	819 09 12-10	Washer 9/32 x 3/4 x 10 Ga.
29	532 07 16-73	Cap Brake Parking	113	532 12 72-85	Strap Torque Lh
30	532 17 49-73	Bracket Mtg Transaxle	116	872 14 06-08	Bolt Rdhd Sq Neck 3/8-16 x 1.00
32	874 76 05-12	Bolt Hex Hd 5/16-18 unc x 3/4	120	873 90 06-00	Nut Lock Flg 3/8-16
34	532 17 55-78	Shaft Asm Pedal Foot	150	532 17 54-56	Spacer Retainer
35	532 12 01-83	Bearing Nylon Blk 629 Id	151	819 13 32-10	Washer 13/32 x 2 x 10
36	819 21 16-16	Washer 21/32 x 1 x 16 Ga.	156	532 16 60-02	Washer Srrted 5/16 ID x 1.125
37	532 12 49-63	Pin Roll 3/16 x 1"	158	532 16 55-89	Bracket Shift Mount
38	532 17 91-14	Pulley Idler Composite	159	532 18 39-00	Hub Tapered Flange Shift It
39	872 11 06-22	Bolt RDHD 3/8-16 unc x 2-3/4 Gr. 5	161	872 14 04-06	Bolt Rdhd Sqnk 1/4-20 x 3/4 Gr. 5
41	532 17 55-56	Keeper Belt Retainer Idler	162	873 68 04-00	Nut Crownlock 1/4-20 unc
47	532 12 77-83	Pulley Idler V Groove Plastic	163	874 78 04-16	Bolt Hex Fin 1/4-20 unc x 1 Gr. 5
48	532 15 44-07	Bellcrank Asm	165	532 16 56-23	Bracket Pivot Lever
49	532 12 32-05	Retainer Belt Style Spring	166	817 49 05-10	Screw 5/16-18 x 5/8
50	872 11 06-12	Bolt Carr Sh 3/8-16 x 1-1/2 Gr. 5	168	532 16 54-92	Bolt Shoulder 5/16-18 x .561
51	873 68 06-00	Nut Crownlock 3/8-16 unc	169	532 16 55-80	Plate Fastening Lt
52	873 68 05-00	Nut Crownlock 5/16-18 unc	170	532 18 74-14	Keeper Belt T/A
53	532 19 96-52	Link Clutch	197	532 16 96-13	Nyliner, Snap - in
55	532 10 57-09	Spring Return Clutch 6 75	198	532 16 95-93	Washer, Nyl.
56	817 06 06-20	Screw 3/8-16 x 1-1/4	202	872 11 06-14	Bolt, 3/8 - 16 x 1-3/4 Gr. 5
57	532 13 82-55	V-Belt Ground Drive	212	532 14 52-12	Nut Flange Hex Lock
59	532 16 96-91	Keeper Belt Span Ctr			
61	817 12 06-14	Screw 3/8-16 x .875			

NOTE: All component dimensions given in U.S. inches
1 inch = 25.4 mm

REPAIR PARTS

TRACTOR -- MODEL NUMBER LT1597 (96011022000), PRODUCT NO. 960 11 02-20
STEERING

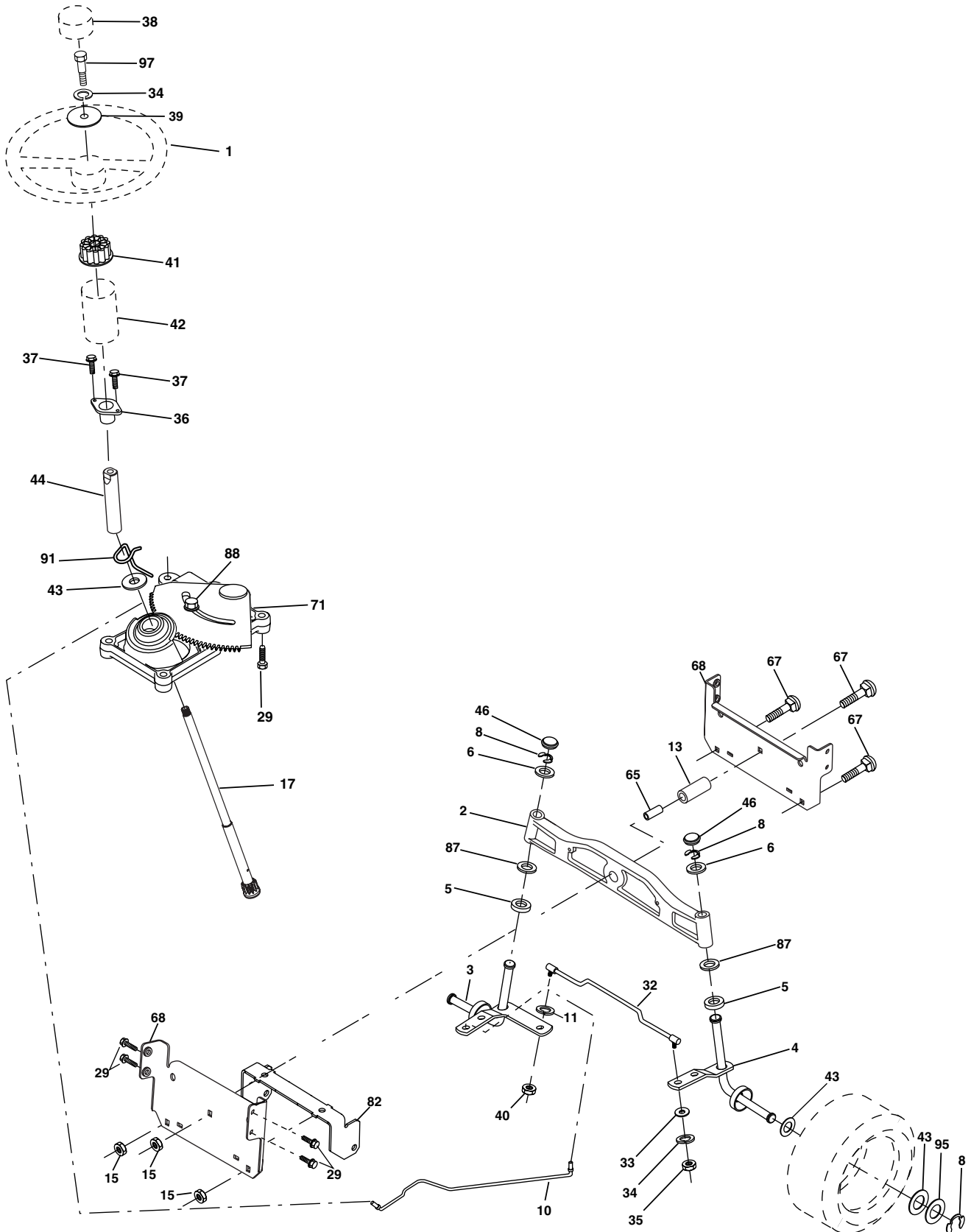

REPAIR PARTS

TRACTOR -- MODEL NUMBER LT1597 (96011022000), PRODUCT NO. 960 11 02-20
STEERING

KEY NO.	PART NO.	DESCRIPTION
1	532 19 39-43	Wheel Steering
2	532 18 47-06	Axle Asm
3	532 16 98-40	Spindle Asm LH
4	532 16 98-39	Spindle Asm RH
5	532 12 49-31	Bearing Race Thrust Harden
6	532 12 17-48	Washer 25/32 x 1-5/8 x 16 Ga.
8	812 00 00-29	Ring Klip #t5304-75
9	532 12 49-37	Bearing Col Strg Blk
10	532 17 51-21	Link Drag
11	810 04 06-00	Washer Lock Hvy Hlcl Spr 3/8
13	532 13 65-18	Spacer Brace Axle
15	532 14 52-12	Nut Hexflange Lock
17	532 19 07-53	Shaft Asm Strg
29	817 00 06-12	Screw 3/8-16 x .75
32	532 17 18-88	Rod Tie
33	819 11 12-16	Washer 11/32 x 3/4 x 16 Ga.
34	810 04 05-00	Washer Lock Hvy HCLC Spr. 5/16
35	873 54 05-00	Crownlock Nut 5/16-24 UNF
36	532 15 50-99	Bushing Strg Nat .623/.618ld
37	532 15 29-27	Screw TT #10-32 x 5 x 3/8 Flange
38	532 19 36-52	Cap Wheel Steer
39	819 11 38-12	Washer 11/32 ID x 2-3/8 OD 12 Ga.
40	873 54 06-00	Nut Crownlock 3/8-24
41	532 18 67-37	Adaptor Wheel Strg
42	532 16 96-34	Boot Shaft Steering
43	532 12 17-49	Washer 25/32 x 1 1/4 x 16 Ga.
44	532 19 07-52	Extension Steering
46	532 12 12-32	Cap Spindle Fr Top Blk
47	532 18 32-26	Fitting Grease
65	532 16 03-67	Spacer Brace Axle
67	872 11 06-18	Bolt RDHD SQ 3/8-16 unc x 2-1/4
68	532 16 98-27	Brace Axle
71	532 17 51-46	Steering Asm.
82	532 19 99-78	Bracket Susp. Chassis Front
87	532 17 39-66	Washer Flat .781 x 1-1/2 x 14
88	532 17 51-18	Bolt Shoulder 7/16-20
91	532 17 55-53	Clip Steering
95	532 18 89-67	Washer Harden .793 x 1.637 x 060
97	874 78 05-64	Bolt 5/16-18 unc x 4"L Gr. 5

NOTE: All component dimensions given in U.S. inches
1 inch = 25.4 mm.

REPAIR PARTS

TRACTOR -- MODEL NUMBER LT1597 (96011022000), PRODUCT NO. 960 11 02-20
ENGINE

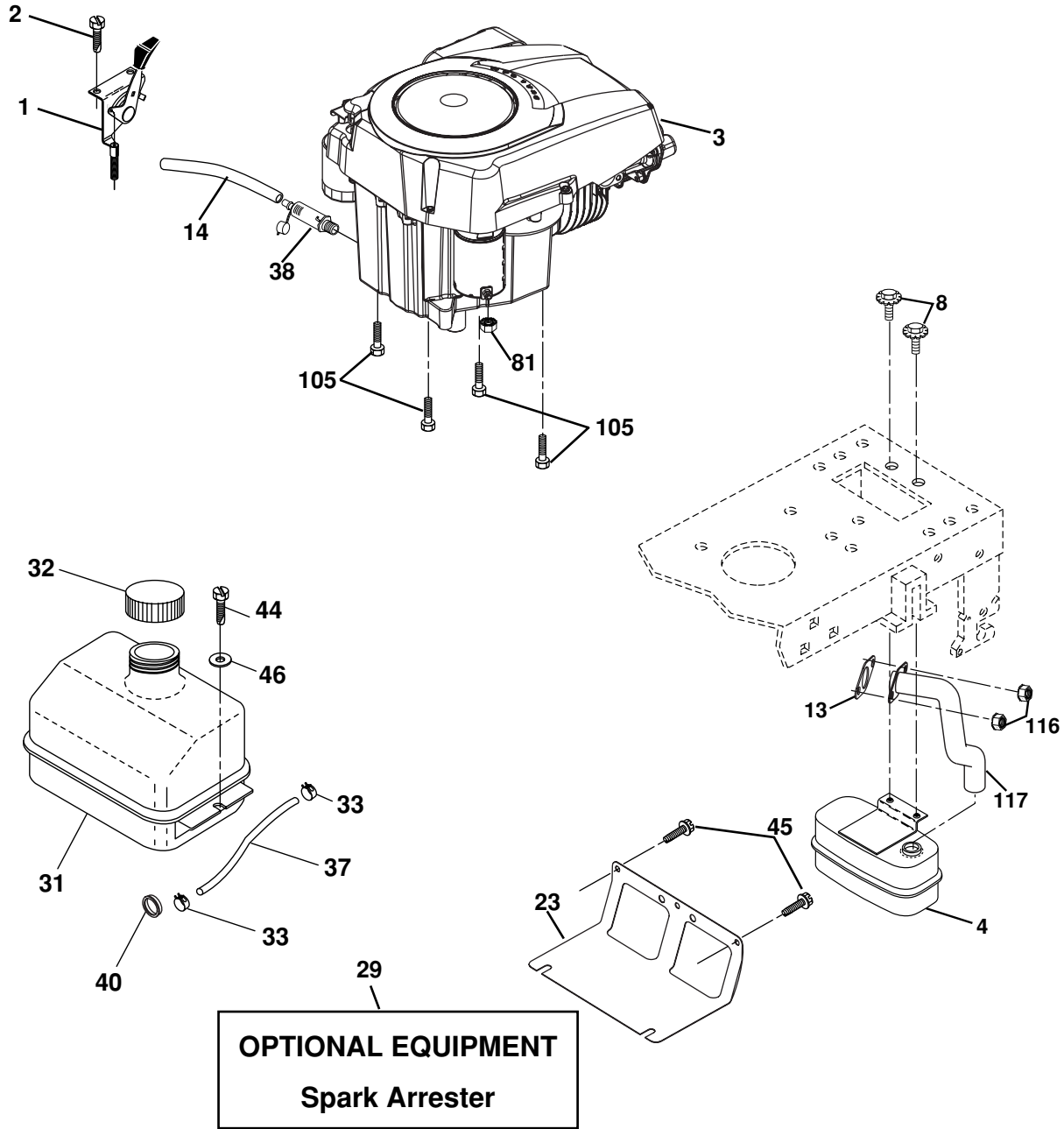

engine-kohler_43

KEY NO.	PART NO.	DESCRIPTION
1	532 17 05-05	Control Throttle
2	817 72 04-08	Screw Hex Thd Cut 1/4-20 x 5/8 T
3	-----	Engine Kohler Model SV470 (Order Parts from Engine Manufacturer)
4	532 18 86-55	Muffler Exhaust
8	532 17 18-77	Bolt 5/16-18 UNC x 3/4 W/Sems
13	532 18 59-09	Gasket
14	532 14 84-56	Tube Drain Oil Easy
23	532 16 98-37	Shield Browning/Debris Guard
29	532 13 71-80	Arrestor Spark
31	532 18 49-00	Tank Fuel
32	532 19 77-25	Cap Asm Fule Top

KEY NO.	PART NO.	DESCRIPTION
33	532 12 34-87	Clamp Hose Blk
37	532 13 70-40	Line Fuel 20"
38	532 18 16-54	Plug Drain Oil Easy
40	532 12 40-28	Bushing Snap
44	817 67 04-12	Screw Hexwsh Thdrol 3/8-16 x 3/4
45	817 00 06-12	Screw 3/8-16 x 3/4
46	819 09 14-16	Washer 9/32 x 7/8 x 16 Ga.
81	873 51 04-00	Nut Keps Hex 1/4-20 unc
105	817 12 06-16	Screw 3/8-16 x 1
116	532 18 43-62	Nut Hex Flange Toplock M8-1.25
117	532 18 86-54	Tube Exhaust

NOTE: All component dimensions given in U.S. inches
1 inch = 25.4 mm

REPAIR PARTS

TRACTOR - - MODEL NUMBER LT1597 (96011022000), PRODUCT NO. 960 11 02-20
SEAT

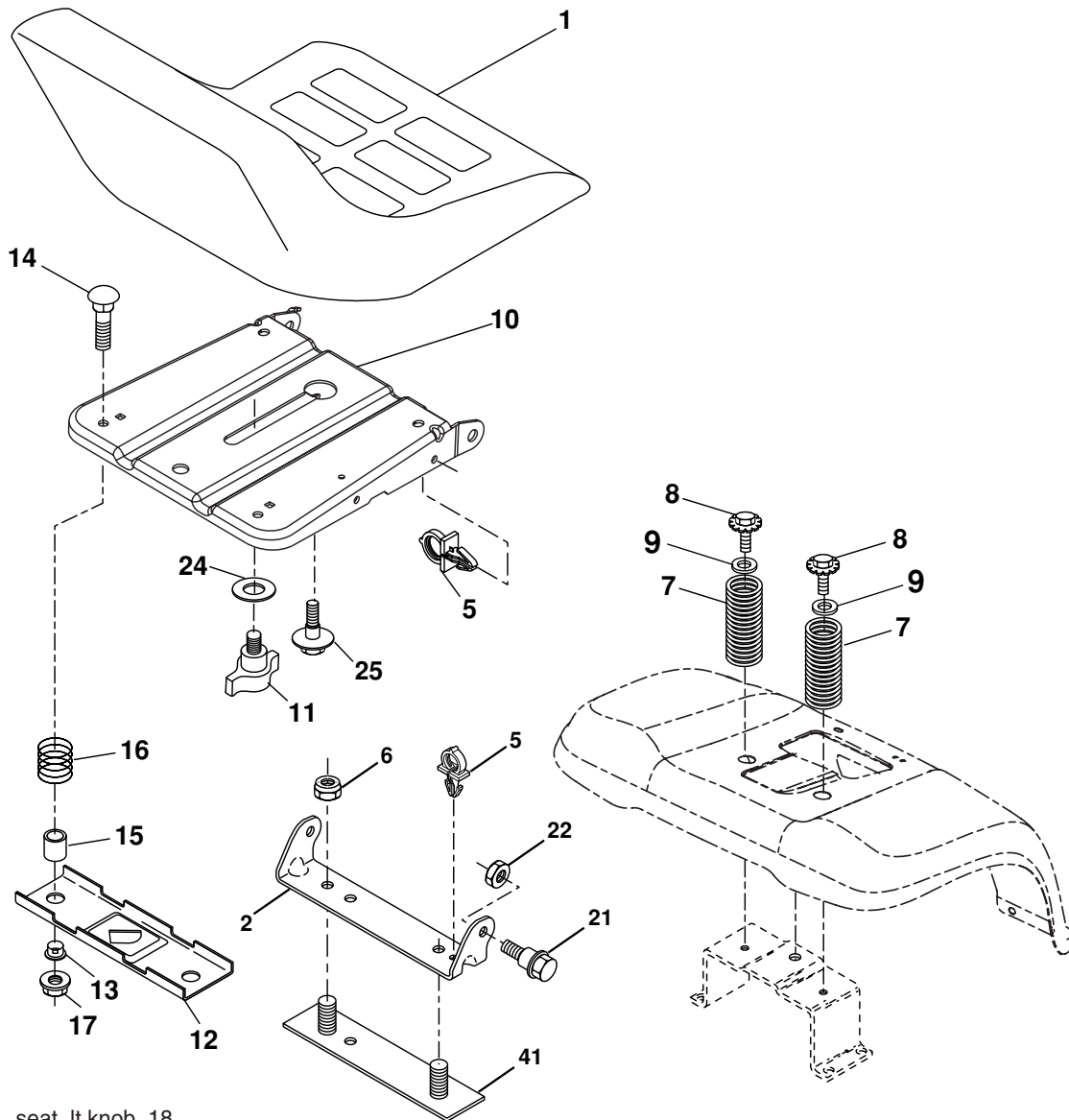

seat_lt.knob_18

KEY NO.	PART NO.	DESCRIPTION
1	532 19 01-20	Seat
2	532 14 05-51	Bracket Pivot
5	532 14 50-06	Clip Push-In
6	873 80 06-00	Nut Lock Hex w/Wsh 3/8-16 unc
7	532 12 41-81	Spring Seat Cprsn 2 250 Blk Zi
8	817 00 06-16	Screw 3/8-16 x 1.5
9	819 13 16-14	Washer 13/32 x 1 x 14 Ga.
10	532 19 55-30	Pan Seat
11	532 16 63-69	Knob Seat
12	532 17 46-48	Bracket Mounting Switch
13	532 12 12-48	Bushing Snap Blk Nyl 50 Id

KEY NO.	PART NO.	DESCRIPTION
14	872 05 04-12	Bolt Rdhd Sht Nk 1/4-20 x 1-1/2
15	532 13 43-00	Spacer Split 28x 96 Yel Zinc
16	532 12 12-50	Spring Cprsn 1 27 Blk Pnt
17	532 12 39-76	Nut Lock 1/4 Lge Flg Gr. 5 Zinc
21	532 17 18-52	Bolt Shoulder 5/16-18 unc -2A
22	873 80 05-00	Nut Lock Hex W/Insert 5/16-18 unc
24	819 17 19-12	Washer 17/32 x 1-3/16 x 12 Ga.
25	532 12 70-18	Bolt Shoulder 5/16-18 x .62
41	532 14 06-75	Strap Asm. Fender

NOTE: All component dimensions given in U.S. inches.
1 inch = 25.4 mm

REPAIR PARTS

TRACTOR -- MODEL NUMBER LT1597 (96011022000), PRODUCT NO. 960 11 02-20
DECALS

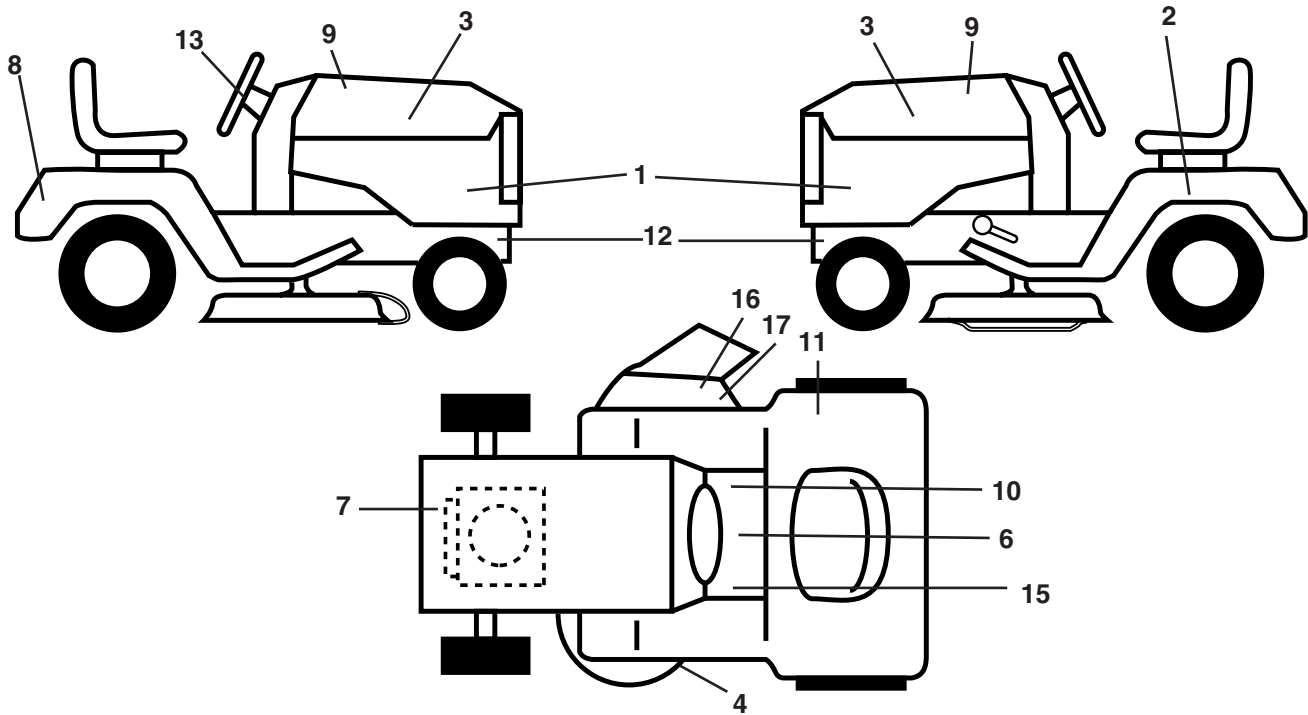

KEY NO.	PART NO.	DESCRIPTION
1	532 40 35-73	Decal, Side Panel
2	532 14 50-05	Decal, Bat Dan/Poi P/L Symbols
3	532 18 89-21	Decal, Hood
4	532 19 43-02	Decal, Schematic
6	532 40 03-89	Decal, Warning/Symbols CE
7	532 19 68-41	Decal, Warning Symbols
8	532 40 35-74	Decal, Fender
9	532 18 89-23	Decal, Hood
10	532 14 08-37	Decal, Brake/Park
11	532 16 88-69	Decal, Fender Tick Mark

KEY NO.	PART NO.	DESCRIPTION
12	532 15 97-36	Decal, Hot Muffler
13	532 18 89-25	Decal, Strg Wheel Cap
15	532 15 97-37	Decal, Brake/Clutch Symbol
16	532 18 21-66	Decal, Cutfinger
17	532 19 63-57	Decal, Warning Symbol
--	532 13 83-11	Decal, Lift Handle (Lift Handle)
--	532 16 25-98	Decal, Load Limit
--	532 18 82-52	Pad Footrest LH
--	53218 82-53	Pad Footrest RH
--	532 40 35-64	Manual Owner's

WHEELS & TIRES

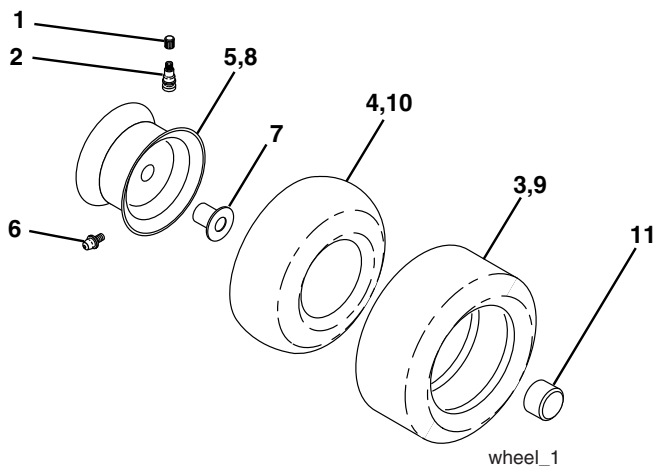

KEY NO.	PART NO.	DESCRIPTION
1	532 05 91-92	Cap Valve Tire
2	532 06 51-39	Stem Valve
3	532 10 62-22	Tire F Ts 15 x 6.0 - 6 Service
4	532 05 99-04	Tube Front (Service Item Only)
5	532 13 83-36	Rim Asm 6" front Service
6	532 12 49-57	Fitting Grease (Front Wheel Only)
7	532 12 49-59	Bearing Flange (Front Wheel Only)
8	532 13 83-37	Rim Asm 8" rear Service
9	532 10 62-68	Tire R Ts 18 x 9.5-8 C. Service
10	532 12 49-26	Tube Rear (Service Item Only)
11	532 17 50-39	Cap Axle Blk 1 50 x 1 00
--	532 14 43-34	Tire, Sealant (10oz. tube)

NOTE: All component dimensions given in U.S. inches
1 inch = 25.4 mm

REPAIR PARTS

TRACTOR - - MODEL NUMBER LT1597 (96011022000), PRODUCT NO. 960 11 02-20
MOWER LIFT

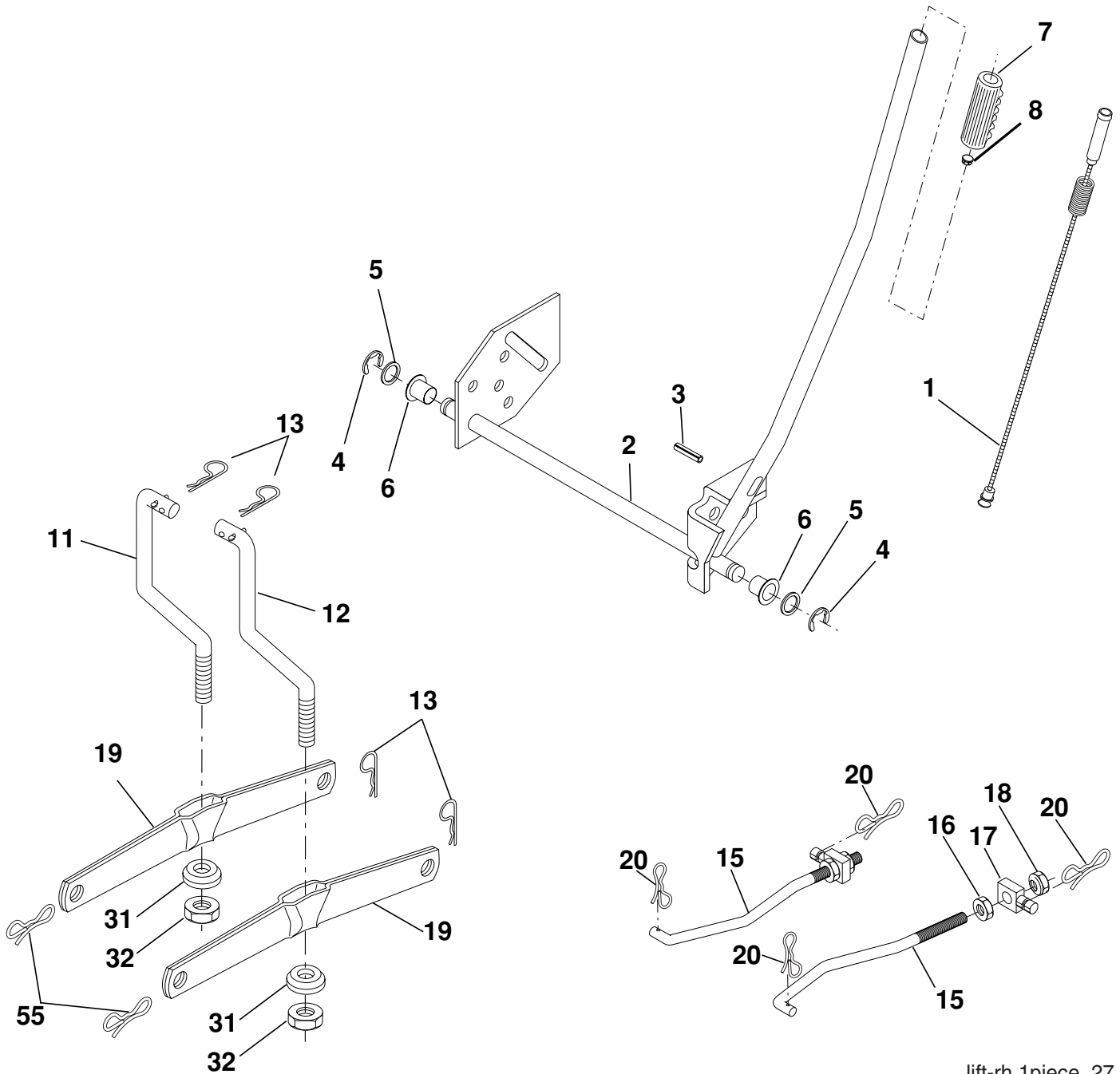

lift-rh.1piece_27

KEY NO.	PART NO.	DESCRIPTION
1	532 15 94-60	Wire Asm Inner W/Plunger
2	532 15 94-71	Shaft Asm Lift
3	532 10 57-67	Pin Groove
4	812 00 00-02	E Ring #5133-62
5	819 21 16-21	Washer PLTD 21/32 x 1 x 21 Ga.
6	532 12 01-83	Bearing Nylon Blk 629 Id
7	532 10 94-13	Grip Handle Bicycle Matte Blk
8	532 12 45-26	Button Plunger Black
11	532 13 98-65	Link Lift LH
12	532 13 98-66	Link Lift RH
13	532 12 46-70	Retainer Spring

KEY NO.	PART NO.	DESCRIPTION
15	532 17 32-88	Link Front
16	873 35 08-00	Nut Jam Hex 1/2-13 unc
17	532 17 56-89	Trunnion
18	873 80 08-00	Nut Lock w/wsh 1/2-13 unc
19	532 13 98-68	Arm Suspension Rear
20	532 19 42-09	Pin Cotter 7/16 Bow Tie Lock
31	532 16 98-65	Bearing Pvt Lift
32	873 54 06-00	Nut Crownlock 3/8-24
55	532 19 42-08	Pin cotter 5/16 Bow Tie Lock

NOTE: All component dimensions given in U.S. inches
1 inch = 25.4 mm

REPAIR PARTS

TRACTOR -- MODEL NUMBER LT1597 (96011022000), PRODUCT NO. 960 11 02-20
MOWER DECK

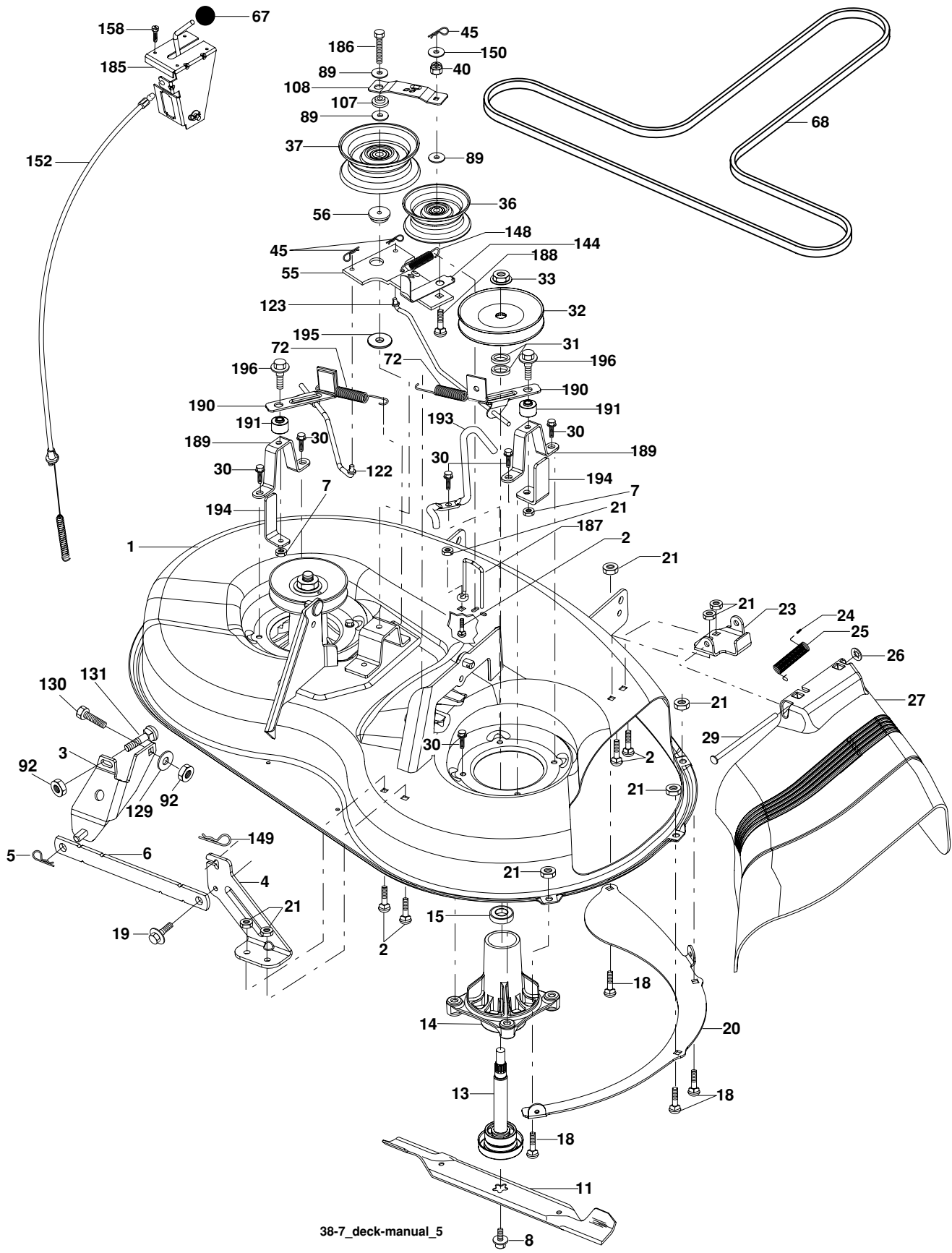

REPAIR PARTS

TRACTOR - - MODEL NUMBER LT1597 (96011022000), PRODUCT NO. 960 11 02-20
MOWER DECK

KEY NO.	PART NO.	DESCRIPTION	KEY NO.	PART NO.	DESCRIPTION
1	532 19 25-56	Mower Housing Assembly	89	819 13 13-11	Washer 13/32 x 13/16 x 11 Ga.
2	872 14 05-06	Bolt Carriage 5/16-18 x 3/4	92	873 80 06-00	Nut Lock Hex W/Ins. 3/8-16 unc
3	532 13 80-17	Bracket Asm Fr. Sway Bar	107	532 13 35-02	Spacer Retainer
4	532 19 25-68	Bracket Deck Sway Bar 38"/42"	108	532 13 35-03	Stiffener, Idler Arm
5	532 12 46-70	Retainer Spring	122	532 19 25-75	Rod, Brake LH
6	532 17 80-24	Bar Sway Deck	123	532 19 25-76	Rod, Brake RH
7	873 80 05-00	Mut Lock Hex W/Ins. 5/16-18 unc	129	819 13 13-12	Washer 13/32 x 13/16 x 12 Ga.
8	532 19 30-03	Bolt 3/8-24 x 1.25 Gr. 8	130	874 78 06-16	Bolt Fin Hex 3/8-16 unc 1 Gr. 5
11	532 19 39-57	Blade Mower	131	872 14 06-08	Bolt RDHD SQNK 3/8-16 unc x 1
13	532 19 28-72	Shaft Assembly, Mandrel, Vented	144	532 19 34-14	Keeper Belt Idler Tension
14	532 18 72-81	Housing, Mandrel, Vented	148	532 16 90-22	Spring Return Idler
15	532 11 04-85	Bearing, Ball, Mandrel	149	532 16 58-98	Retainer Spring Yellow
18	872 14 05-05	Bolt Rdhd Sqnk 5/16-18 x 5/8	150	819 09 12-10	Washer 9/32 x 3/4 x 10 Ga.
19	532 13 28-27	Bolt, Shoulder	152	532 19 32-35	Clutch Cable 38"/46"
20	532 40 00-95	Baffle Vortex Front	158	817 72 04-08	Screw Hex Thd Cut 1/4-20 x 1/2
21	873 68 05-00	Nut	185	532 18 82-34	Head Asm Cable Clutch
23	532 19 25-57	Bracket, Mower Deflector	186	817 49 06-44	Screw Hex Wsh Thdrol 3/8-16 x 2-3/4
24	532 10 53-04	Cap, Sleeve	187	532 19 34-12	Keeper Belt
25	532 19 70-26	Spring, Torsion, Deflector	188	532 16 58-91	Bolt Carriage Idler
26	532 11 04-52	Nut, Push	189	532 19 25-59	Stand, Brake
27	532 40 14-72	Shield, Deflector	190	532 19 25-60	Arm, Brake
29	532 13 14-91	Rod, Hinge	191	532 19 25-61	Spacer, Brake
30	532 17 39-84	Screw Thdrol.	192	532 19 37-82	Bolt/Washer Asm 5/16-18
31	532 18 76-90	Washer, Spacer	193	532 19 34-13	Keeper Belt Rh Mandrel
32	532 15 35-32	Pulley, Mandrel	194	532 19 41-05	Guard Brake
33	532 40 02-34	Nut, Toplock	195	819 13 32-10	Washer
36	532 13 14-94	Pulley, Idler, Flat	--	532 19 25-58	Brake Assembly (Includes Stand, Arm and Guard Components)
37	532 19 31-98	Pulley Idler Flat	--	532 19 28-70	Mandrel Assembly (Includes Hous- ing, Shaft and Shaft Hardware Only - Pulley Not Included)
40	873 68 06-00	Nut, Crownlock 3/8-16 unc	--	532 19 36-46	Replacement Mower, Complete
45	532 12 47-88	Retainer			
46	532 13 77-29	Screw Thd Roll 4/4-20 x 5/8			
55	532 13 38-40	Idler Arm Assembly			
56	532 16 57-23	Spacer, Retainer			
67	532 10 69-32	Knob			
68	532 19 32-14	V-Belt			
72	532 19 32-16	Spring Brake Return			

NOTE: All component dimensions given in U.S. inches
1 inch = 25.4 mm