

# YTH151

**Spare parts**

**Ersatzteile**

**Pièces détachées**

**Reserve onderdelen**

**Repuestos**

**Reservdelar**

# ILLUSTRATED PARTS LIST

**MODEL NO. 96011011600**

**CUSTOMER CATALOG NO. YTH151**

**PRODUCT NO. 960 11 01-16**

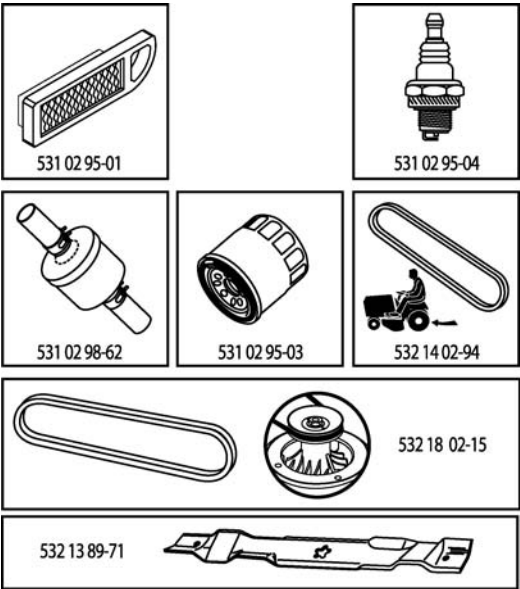

401052

# REPAIR PARTS

TRACTOR - MODEL NO. YTH151 (96011011600), PRODUCT NO. 960 11 01-16  
DECALS

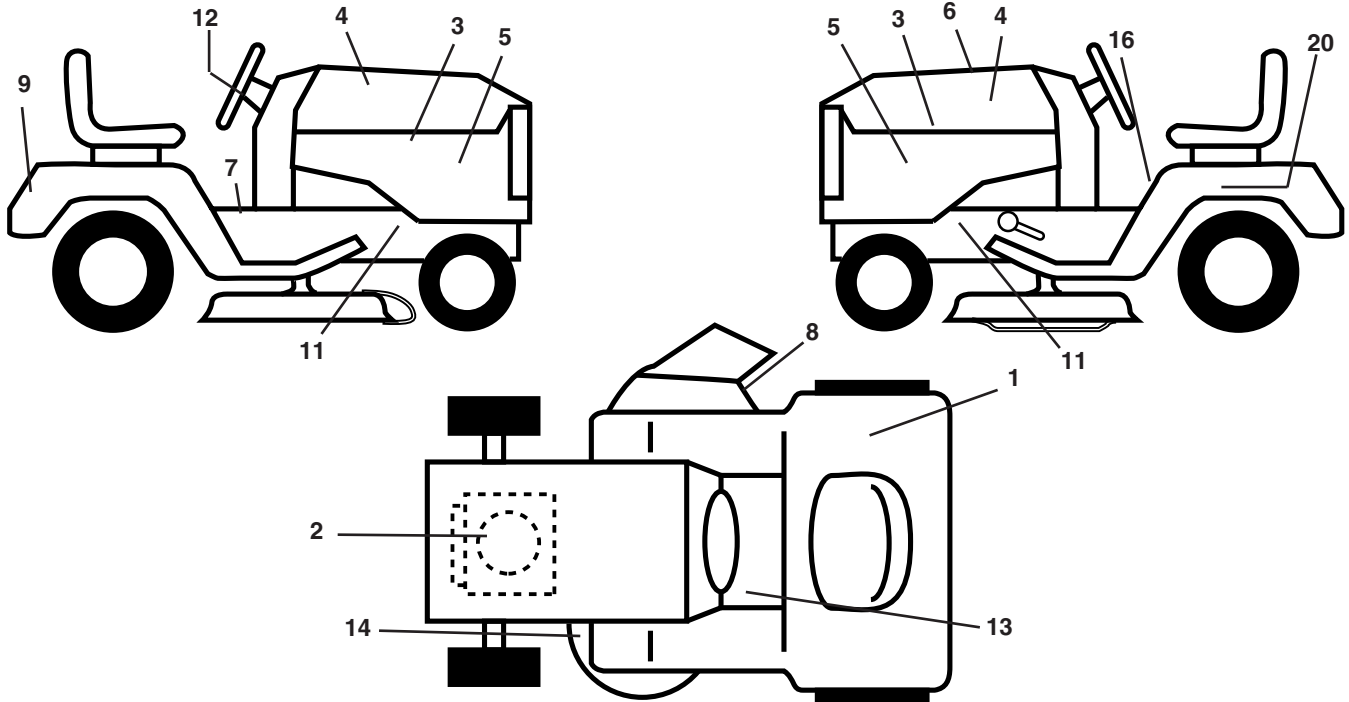

KEY NO.	PART NO.	DESCRIPTION	KEY NO.	PART NO.	DESCRIPTION
1	532 18 04-32	Decal, 100 DB/CE	14	532 16 03-96	Decal, V-Belt Schematic
2	532 19 68-41	Decal, Warning Eng. Syms.	16	532 40 03-89	Decal, Warning
3	532 18 89-21	Decal, Hood	20	532 14 50-05	Decal, Bat Dan/Psn
4	532 18 89-23	Decal, Hood SV Engine	--	532 16 25-98	Decal, Drawbar Load Limit
5	532 19 11-52	Decal, Panel Side	--	532 16 69-60	Decal, By-Pass Lt Hydro
6	532 40 10-52	Decal, Replacement	--	532 13 83-11	Decal, Handle Lft Height Adjust
7	532 14 08-37	Decal, Saddle Brake	--	532 18 82-52	Pad Footrest LH STLT
8	532 18 21-66	Decal, Mower Cutfingng Symbol	--	532 18 82-53	Pad Footrest RH STLT
9	532 18 89-37	Decal, Fender Husq	--	532 40 17-43	Manual Operator's (Euro.)
11	532 15 97-36	Decal, Chassis Hot Muffler	--	532 40 14-86	Manual Operator's (Scand)
12	532 18 89-25	Decal, Wheel Steering	--	532 40 30-45	Manual Operator's (EBloc)
13	532 15 97-37	Decal, Brake/Clutch Symbol LT	--	532 40 30-46	Manual Operator's (Baltic)

## WHEELS & TIRES

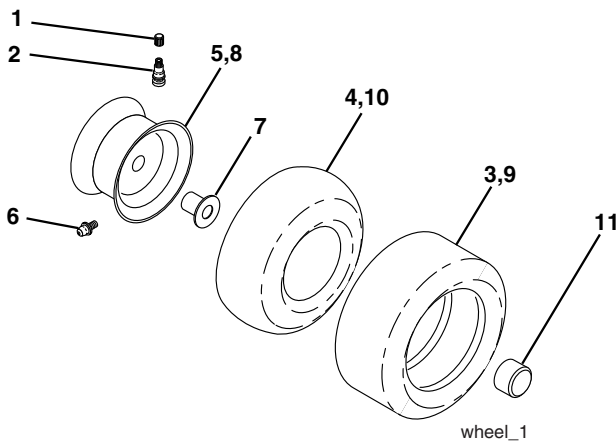

KEY NO.	PART NO.	DESCRIPTION
1	532 05 91-92	Cap Valve Tire
2	532 06 51-39	Stem Valve
3	532 10 62-22	Tire F Ts 15 x 6 0 - 6 Service
4	532 05 99-04	Tube Front (Service Item Only)
5	532 13 83-36	Rim Asm 6" front Silver Service
6	532 12 49-57	Fitting Grease (Front Wheel Only)
7	532 12 49-59	Bearing Flange (Front Wheel Only)
8	532 13 83-37	Rim Asm 8" rear Silver Service
9	532 12 20-82	Tire R Ts 20 x 10-8 C Service
10	532 12 49-26	Tube Rear (Service Item Only)
11	532 17 50-39	Cap Axle Blk 1 50 x 1 00
--	532 14 43-34	Sealant, Tire ( 10 oz. Tube)

**NOTE:** All component dimensions given in U.S. inches  
1 inch = 25.4 mm

# TRACTOR - MODEL NO. YTH151 (96011011600), PRODUCT NO. 960 11 01-16 SCHEMATIC

03054 (197428)

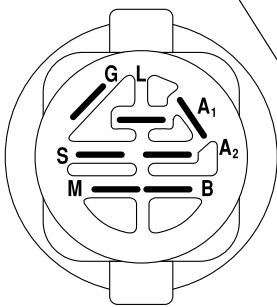
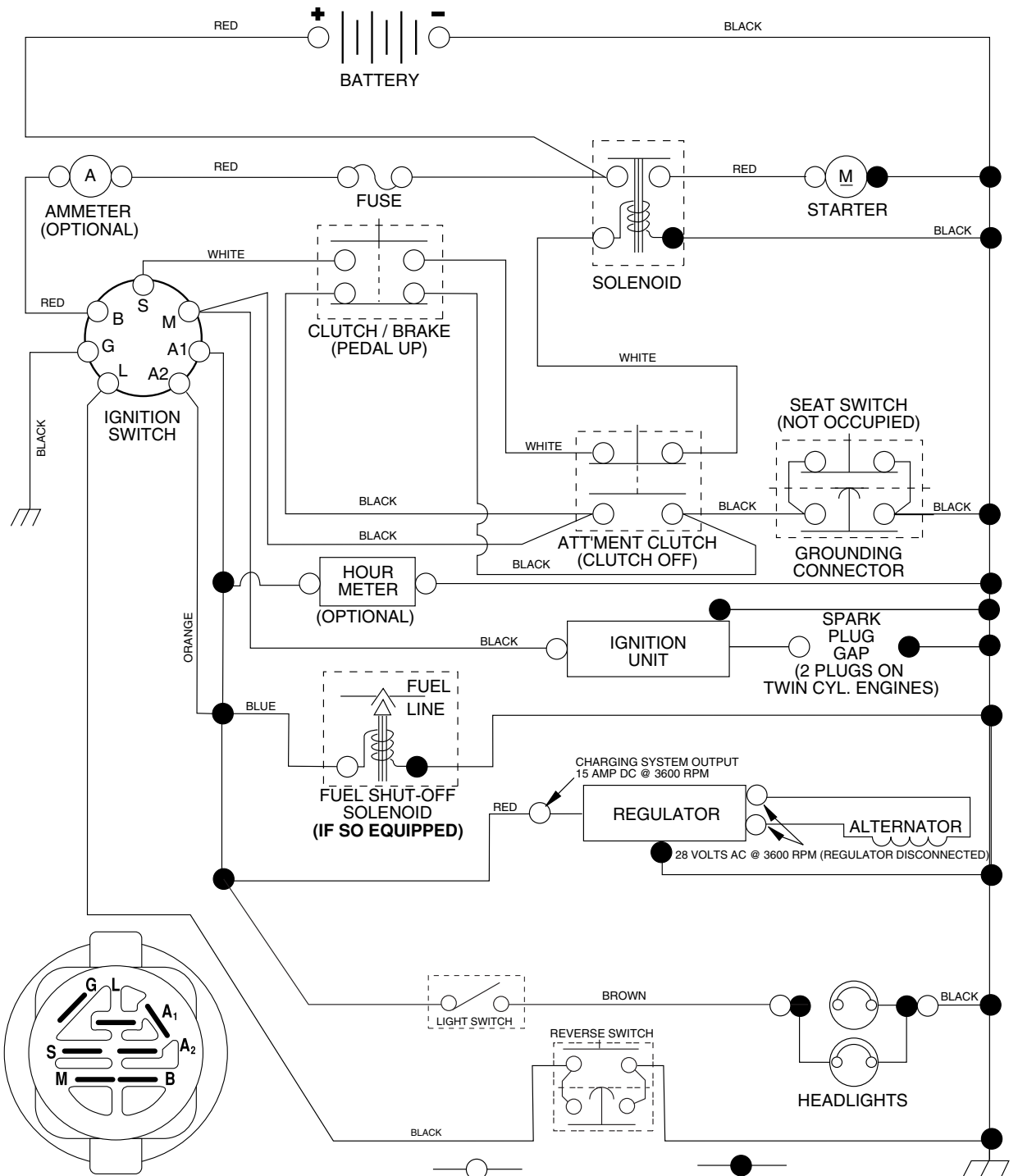

**IGNITION SWITCH**

POSITION	CIRCUIT "MAKE"
OFF	M+G+A1
RUN/OVERRIDE	B+A1
RUN	B+A1 L+A2
START	B + S + A1

3054

REMOVABLE CONNECTIONS

NON-REMOVABLE CONNECTIONS

**WIRING INSULATED CLIPS**

**NOTE:** IF WIRING INSULATED CLIPS WERE REMOVED FOR SERVICING OF UNIT, THEY SHOULD BE REPLACED TO PROPERLY SECURE YOUR WIRING.

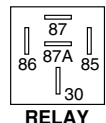

# REPAIR PARTS

TRACTOR - MODEL NO. YTH151 (96011011600), PRODUCT NO. 960 11 01-16  
ELECTRICAL

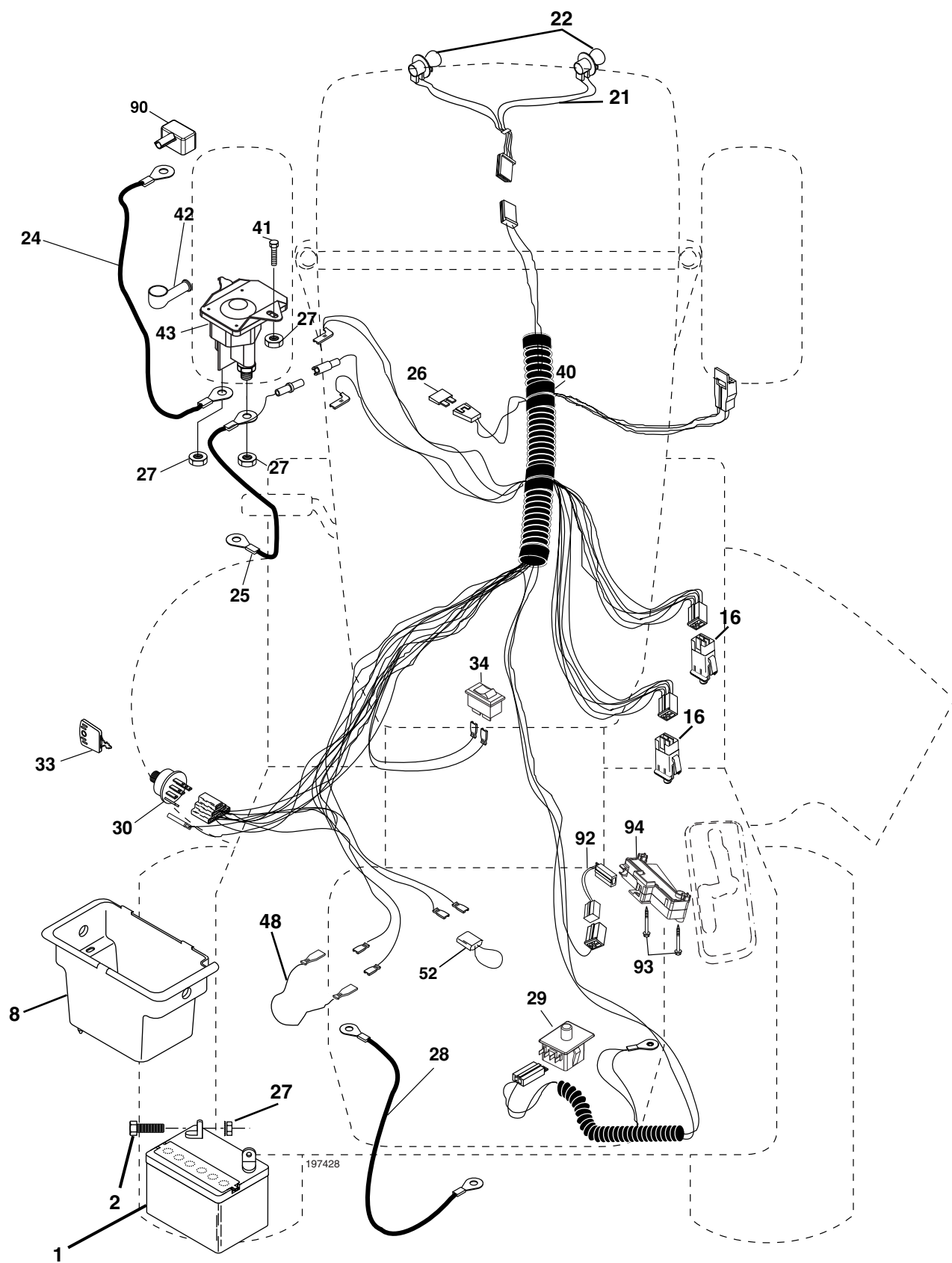

# REPAIR PARTS

TRACTOR - MODEL NO. YTH151 (96011011600), PRODUCT NO. 960 11 01-16  
ELECTRICAL

KEY NO.	PART NO.	DESCRIPTION
1	532 14 49-27	Battery 12 Volt 35 AMP
2	874 76 04-12	Bolt Hex Hd 1/4-20 unc x 3/4
8	532 17 66-89	Box Battery
16	532 17 61-38	Switch Interlock Push-In
21	532 17 56-88	Harness Asm Light W/4152j
22	532 00 41-52	Bulb Light #1156
24	532 12 47-80	Cable Battery 6 Ga. 11" red
25	532 14 61-47	Cable Battery 6 Ga. 44" red w/16 wire
26	532 17 51-58	Fuse 20 AMP
27	873 51 04-00	Nut Keps Hex 1/4-20 unc
28	532 12 47-73	Cable Ground 6 Ga. 12" black
29	532 19 27-49	Switch Seat
30	532 19 33-50	Switch Ignition
33	532 14 04-01	Key Ign Molded Generic
34	532 11 07-12	Switch Light
40	532 19 74-28	Harness Ignition
41	871 11 04-08	Bolt Blk Fin Hex 1/4 - 20 x 1/2
42	532 13 15-63	Cover Terminal Red
43	532 19 25-07	Solenoid
48	532 14 08-44	Adapter Ammeter Rectangular
52	532 14 19-40	Protection Wire Loop
90	532 18 04-49	Cover Terminal Battery
92	532 19 66-15	Harnais Pigtail
93	532 19 25-40	Screw Plastite 10 - 14 x 2.0
94	532 19 18-34	Module Reverse

**NOTE:** All component dimensions given in U.S. inches.  
1 inch = 25.4 mm.

# REPAIR PARTS

TRACTOR - MODEL NO. YTH151 (96011011600), PRODUCT NO. 960 11 01-16  
CHASSIS AND ENCLOSURES

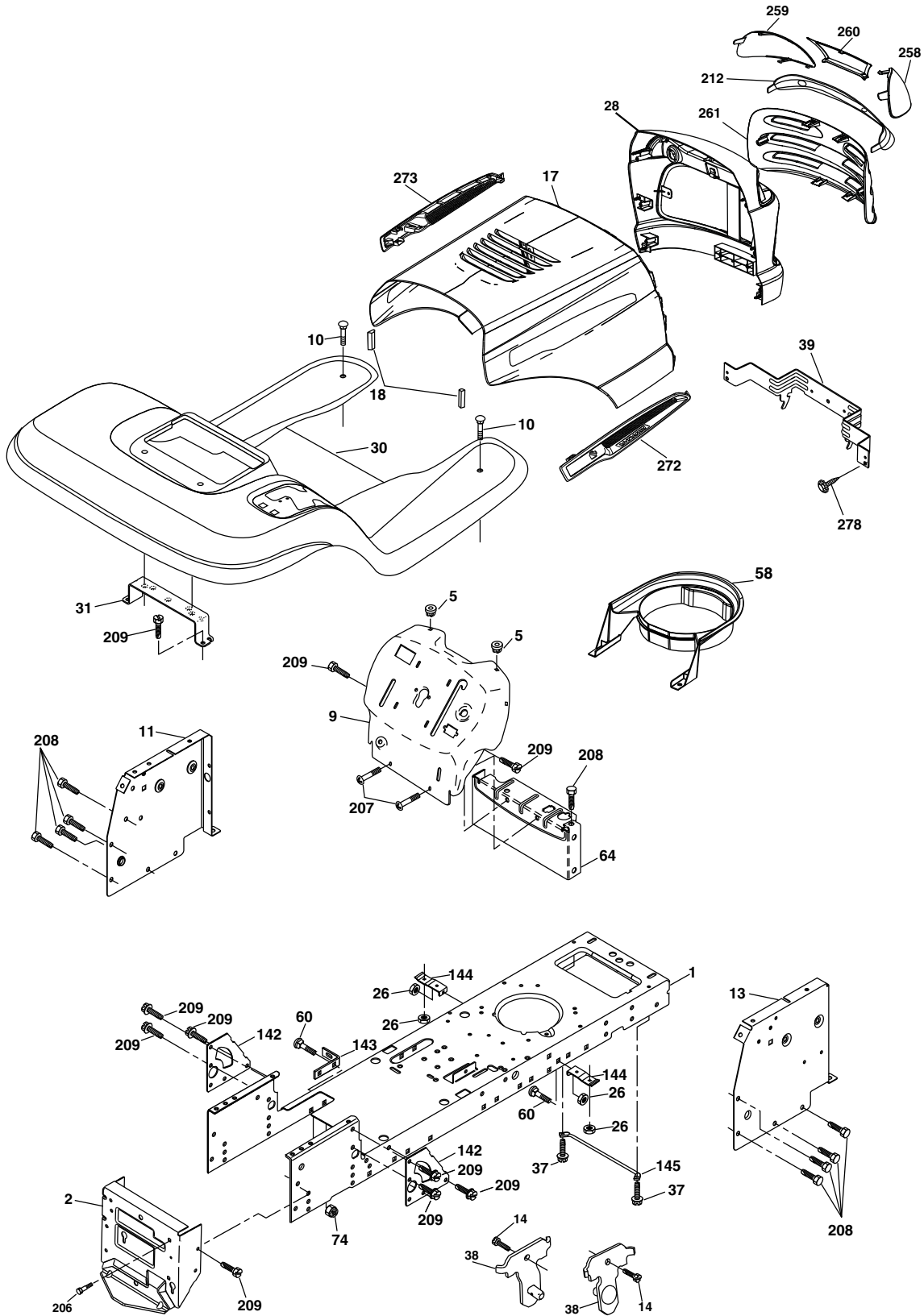

# REPAIR PARTS

## TRACTOR - MODEL NO. YTH151 (96011011600), PRODUCT NO. 960 11 01-16 CHASSIS AND ENCLOSURES

KEY NO.	PART NO.	DESCRIPTION
1	532 17 46-19	Chassis Stamping
2	532 17 65-54	Drawbar
5	532 15 52-72	Bumper Hood/Dash
9	532 19 39-37	Dash P/L M
10	872 14 06-08	Bolt Carriage 3/8-16 x 1
11	532 17 49-96	Panel Dash Lh
13	532 18 17-19	Panel Dash Rh
14	817 49 06-08	Screw 3/8-16 x 1/2
17	532 18 88-93	Hood Laser
18	532 18 49-21	Bumper Hood
26	873 80 06-00	Nut Lock Hex W/Ins 3/8-16 unc
28	532 18 35-38	Grille/Lens Asm. (Includes #'s 212, 258-259)
30	532 19 39-38	Fender Footrest STLT Pnt
31	532 13 99-76	Bracket Support Fender
37	817 49 05-08	Screw Thdrol 5/16-18 x 1/2 TYT
38	532 17 57-10	Bracket Asm Pivot Mower Rear
39	532 17 47-14	Bracket Pivot Laser
58	532 18 71-54	Duct Air
60	872 14 06-06	Bolt Rdhd Sqnk 3/8-16 unc x 3/4
64	532 15 47-98	Dash Lower STLT
74	873 68 06-00	Nut Crownlock 3/8-16 unc
142	532 17 57-02	Plate Reinforcement STLT
143	532 18 66-89	Bracket Swaybar Chassis
144	532 17 55-82	Bracket Pnt Footrest STLT
145	532 15 65-24	Rod Pivot Chassis/Hood
206	532 17 01-65	Bolt Shoulder 5/16-18 TT
207	817 67 05-08	Screw Thdrol 5/16-18 x 1/2 TYTT
208	817 67 06-08	Screw Thdrol 3/8-16 x 1/2 TYT BI
209	817 00 06-12	Screw Thdrol Hexwash 3/8-16 x 3/4
212	532 18 35-48	Insert Lens Reflect
258	532 18 52-14	Lens RH
259	532 18 52-13	Lens LH
260	532 18 52-16	Cover Lens
261	532 18 52-12	Insert Grille
272	532 18 88-96	Vent Hood RH
273	532 18 88-95	Vent Hood LH
278	532 19 16-11	Screw 10 x 34 Single Lead Hex
--	532 00 54-79	Plug Button
--	532 18 78-01	Plug Dome Plastic

**NOTE:** All component dimensions given in U.S. inches  
1 inch = 25.4 mm



# REPAIR PARTS

TRACTOR - MODEL NO. YTH151 (96011011600), PRODUCT NO. 960 11 01-16  
DRIVE

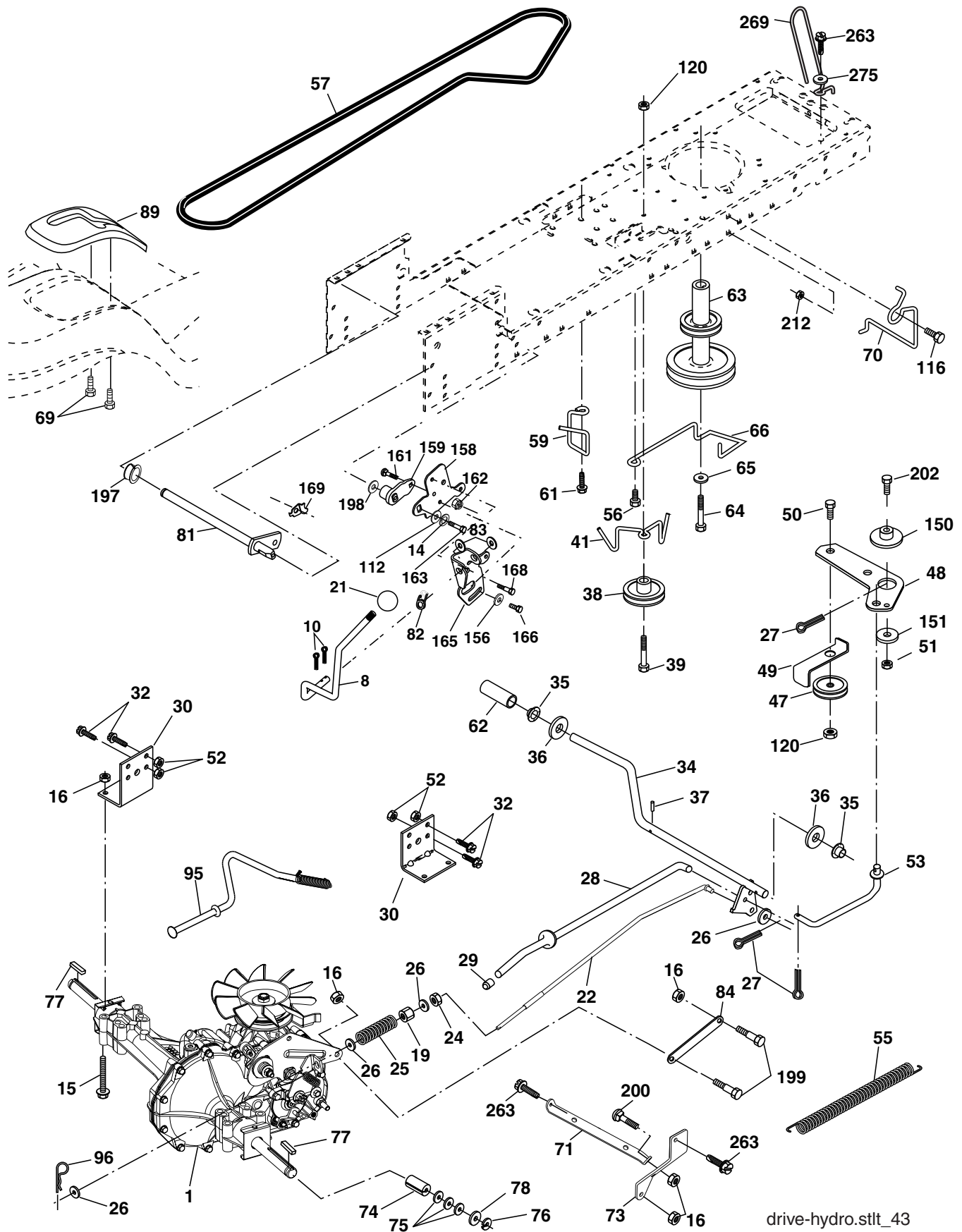

# REPAIR PARTS

TRACTOR - MODEL NO. YTH151 (96011011600), PRODUCT NO. 960 11 01-16  
DRIVE

KEY NO.	PART NO.	DESCRIPTION	KEY NO.	PART NO.	DESCRIPTION
1	-----	Transaxle Hydro Gr 314-0510 (Order parts from transaxle manufacturer)	69	532 14 24-32	Screw Hex Wsh Hi-Lo 1/4 x 1/2 unc
8	532 19 25-02	Rod Shift Fender STLT	70	532 18 02-18	Guide Belt Mower Drive RH
10	876 02 04-16	Pin Cotter 1/8 x 1 CAD	71	532 16 91-83	Strap Torque Lh Hydro
14	810 04 04-00	Washer Lock Hvy Helical 1/4	73	532 16 91-82	Strap Torque Rh Hydro
15	874 49 05-44	Bolt Hex Flg Hd 5/16-18 x Gr.5	74	532 13 70-57	Spacer, Axle
16	873 80 05-00	Nut Lock Hex W/Ins. 5/16-18 unc P	75	532 12 17-49	Washer 25/32 x 1-1/4 x 16 Ga.
19	873 80 06-00	Nut Lock Hex W/Wsh 3/8-16 unc	76	812 00 00-01	E-Ring
21	532 12 12-74	Knob, Duckhead	77	532 12 35-83	Key, Square
22	532 16 94-98	Rod, Brake Hydro	78	532 12 17-48	Washer 25/32 x 1-5/8 x 16 Ga.
24	873 35 06-00	Nut	81	532 16 55-96	Shaft Asm. Cross Hydro
25	532 10 68-88	Spring, Brake Rod	82	532 16 57-11	Spring Torsion T/A
26	819 13 13-16	Washer	83	819 17 12-16	Washer 17/32 x 3/4 x 16 Ga.
27	876 02 04-12	Pin Cotter 1/8 x 3/4 CAD.	84	532 16 95-94	Link Transaxle
28	532 17 57-65	Rod, Parking Brake	89	532 19 48-10	Console, Shift
29	532 07 16-73	Cap, Parking Brake	95	532 17 02-01	Control Asm Bypass Hydro
30	532 16 95-92	Bracket, Transaxle	96	532 12 47-88	Retainer Spring 1" Zinc/Cad
32	874 76 05-12	Bolt Hex Hd 5/16-18 unc x 3/4	112	819 09 12-10	Washer 9/32 x 3/4 x 10 Ga.
34	532 17 55-78	Shaft, Foot Pedal	116	872 14 06-08	Boulon 3/8-16 x 1
35	532 12 01-83	Bearing, Nylon	120	873 90 06-00	Nut Lock 3/8-16
36	819 21 16-16	Washer	150	532 17 54-56	Retainer Spacer
37	532 12 49-63	Pin, Roll	151	819 13 32-10	Washer 13/32 x 2 x 10 Ga.
38	532 17 91-14	Pulley, Idler, Composite	156	532 16 60-02	Washer Srrtd 5/16 ID x 1.0 x .125 Tk
39	872 11 06-22	Bolt Rdhd 3/8-16 unc x 3/4 Gr. 5	158	532 16 55-89	Bracket Shift Mount
41	532 17 55-56	Keeper, Belt Idler	159	532 18 39-00	Hub Tapered Flange Shift LT
47	532 12 77-83	Pulley, Idler, V-Groove	161	872 14 04-06	Bolt Rdhd Sqnk 1/4-20 x 3/4 Gr. 5
48	532 15 44-07	Bellcrank Clutch Grnd Drv Stl	162	873 68 04-00	Nut Crownlock 1/4-20 unc
49	532 12 32-05	Retainer, Belt	163	874 78 04-16	Bolt Hex Fin 1/4-20 unc x 1 Gr. 5
50	872 11 06-12	Bolt Carr SH 3/8-16 unc x 1-1/2 Gr. 5	165	532 16 56-23	Bracket Pivot Lever
51	873 68 06-00	Nut Crownlock 3/8-16	166	817 49 05-10	Screw 5/16-18 x 5/8 TT Yellow
52	873 68 05-00	Nut Crownlock 5/16-18	168	532 16 54-92	Bolt Shoulder 5/16-18 x .561 TT
53	532 19 96-52	Link, Clutch	169	532 16 55-80	Plate Fastening Cross Shf. STLT/ CRD
55	532 10 57-09	Spring, Return, Clutch	197	532 16 96-13	Nyliner Snap-In 5/8" ID
56	817 06 06-20	Screw 3/8-16 x 1-1/4	198	532 16 95-93	Washer Nyl 7/8 ID x .105 HYD CRD
57	532 14 02-94	V-Belt, Ground Drive	199	532 16 96-12	Bolt Shoulder 5/16-18 unc
59	532 16 96-91	Keeper, Center Span	200	872 14 05-08	Bolt Rdhd Sqnk 5/16-18 unc x 1
61	817 12 06-14	Screw 3/8-16 x .875	202	872 11 06-14	Bolt Rdhd 3/8-16 unc x 1-3/4 Gr. 5
62	532 12 35-33	Cover, Pedal	212	532 14 52-12	Nut Hex Flange Lock
63	532 18 02-19	Pulley, Eng	263	817 00 06-12	Screw 3/8-16 x 3/4
64	532 17 39-37	Bolt Hex 7/16-20 x 4 x Gr. 5-1.5 Thr	269	532 18 24-02	Guard Muffler RH
65	810 04 07-00	Washer	275	819 13 16-14	Washer 13/32 x1 x 14 Ga.
66	532 15 47-78	Keeper Belt Engine			

**NOTE:** All component dimensions given in U.S. inches  
1 inch = 25.4 mm

# REPAIR PARTS

TRACTOR - MODEL NO. YTH151 (96011011600), PRODUCT NO. 960 11 01-16  
STEERING ASSEMBLY

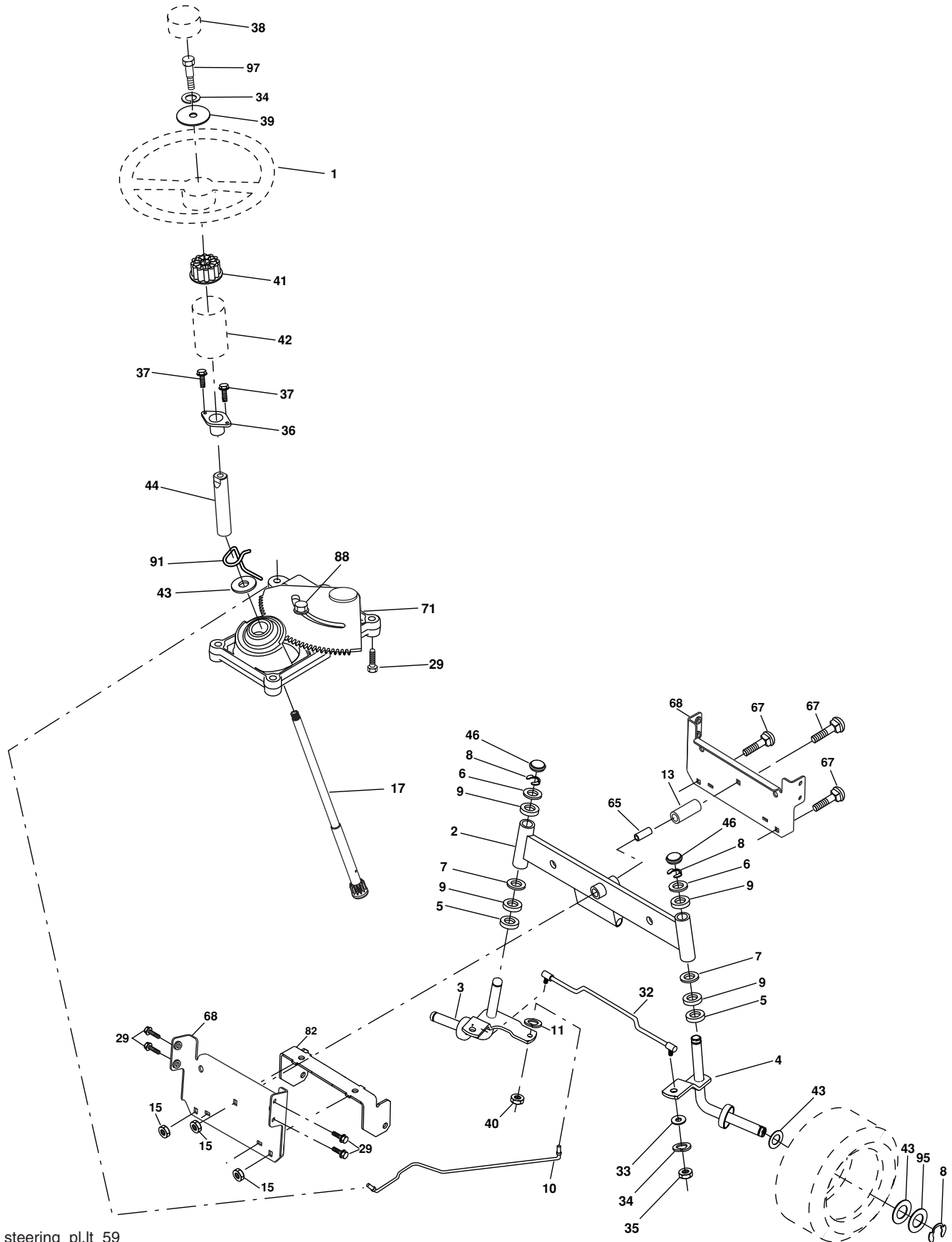

# REPAIR PARTS

TRACTOR - MODEL NO. YTH151 (96011011600), PRODUCT NO. 960 11 01-16  
STEERING ASSEMBLY

KEY NO.	PART NO.	DESCRIPTION
1	532 19 36-51	Wheel Steering
2	532 19 56-73	Axle Asm
3	532 16 98-40	Spindle Asm LH
4	532 16 98-39	Spindle Asm RH
5	532 12 49-31	Bearing Race Thrust Harden
6	532 12 17-48	Washer 25/32 x 1-5/8 x 16 Ga.
7	819 27 20-16	Washer 27/32 x 1-1/4 x 16 Ga.
8	812 00 00-29	Ring Klip #t5304-75
9	532 12 49-37	Bearing Col Strg Blk
10	532 17 51-21	Link Drag
11	810 04 06-00	Washer Lock Hvy Hlcl Spr 3/8
13	532 13 65-18	Spacer Brg Axle Front
15	532 14 52-12	Nut Hexflange Lock
17	532 19 07-53	Shaft Asm Strg
29	817 00 06-12	Screw 3/8-16 x 3/4
32	532 17 18-88	Rod Tie BJ Solid
33	819 11 12-16	Washer 11/32 x 3/4 x 16 Ga.
34	810 04 05-00	Washer Lock 5/16
35	873 54 05-00	Crownlock Nut 5/16-24 unf
36	532 15 50-99	Bushing Strg
37	532 15 29-27	Screw
38	532 19 36-52	Insert Cap Strg Wh
39	819 11 38-12	Washer 11/32 ID x 2/3/8 OD 12 Ga.
40	873 54 06-00	Nut Crownlock 3/8-24
41	532 18 67-37	Adaptor Wheel Strg
42	532 16 96-34	Boot Steering Shaft
43	532 12 17-49	Washer 25/32 x 1 1/4 x 16 Ga.
44	532 19 07-52	Extension Steering Shaft LR/LT
46	532 12 12-32	Cap Spindle Fr Top Blk
65	532 16 03-67	Spacer Brace Axle
67	872 11 06-18	Bolt Rdhd Sqnk 3/8-16 x 2-1/4
68	532 16 98-27	Axle, Brace
71	532 17 51-46	Steering Asm.
82	532 19 99-78	Bracket Susp Chassis Front
88	532 17 51-18	Bolt Shoulder 7/16-20 unc
91	532 17 55-53	Clip Steering
95	532 18 89-67	Washer Harden
97	874 78 05-64	Bolt 5/16-18 unc x 4 " L Gr. 5

**NOTE:** All component dimensions given in U.S. inches.  
1 inch = 25.4 mm.

# REPAIR PARTS

TRACTOR - MODEL NO. YTH151 (96011011600), PRODUCT NO. 960 11 01-16  
ENGINE

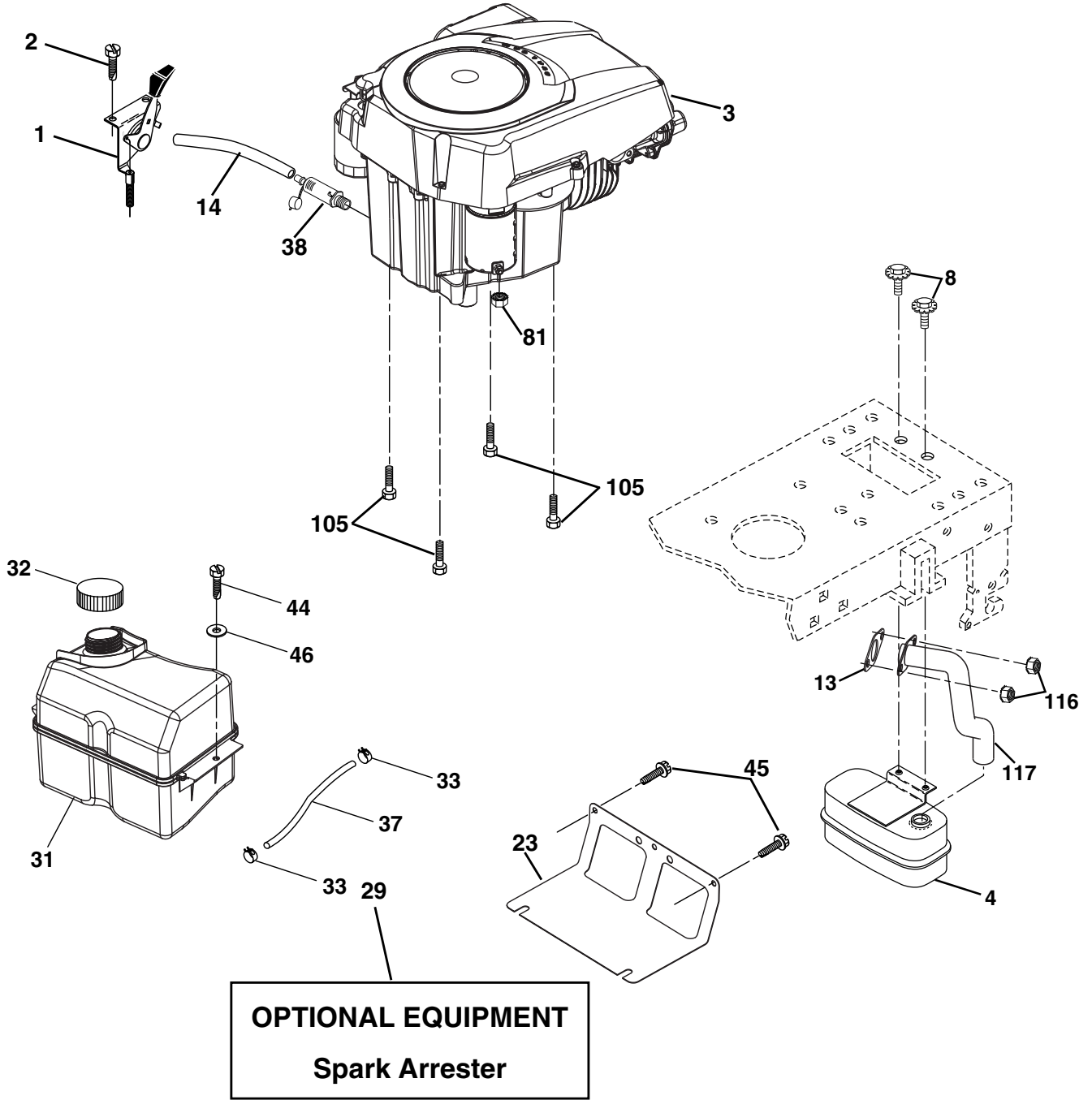

# REPAIR PARTS

TRACTOR - MODEL NO. YTH151 (96011011600), PRODUCT NO. 960 11 01-16  
ENGINE

KEY NO.	PART NO.	DESCRIPTION
1	532 17 08-05	Control Th/ch Flag
2	817 72 04-08	Screw Hex Thd Cut 1/4-20 x 1/2
3	-----	Engine Kohler Model No. SV470 (Order Parts From Engine Manufacturer)
4	532 18 86-55	Muffler
8	532 17 18-77	Bolt 5/16-18 unc x 3/4 w sems
13	532 18 59-09	Gasket Engine
14	532 14 84-56	Tube Drain Oil Easy
23	532 16 98-37	Shield Browning/Debris Guard
29	532 13 71-80	Kit Spark Arrestor (Flat Scrn)
31	532 18 55-34	Tank Fuel Front 2 00
32	532 19 77-25	Cap Asm Fuel Top
33	532 12 34-87	Clamp Hose Black
37	532 13 70-40	Line Fuel 20"
38	532 18 16-54	Plug Drain Oil Easy
44	817 67 04-12	Screw Hexwsh Thdrol 1/4-20 x 3/4
45	817 00 06-12	Screw Hex Wsh Thdr 3/8-16 x 3/4
46	819 09 14-16	Washer 9/32 x 7/8 x 16 Ga.
81	873 51 04-00	Nut Keps Hex 1/4-20 Starter Nut
105	817 12 06-16	Screw 3/8-16 x 1
116	532 18 43-62	Nut Hex Flange Toplock M8-1.25
117	532 18 86-54	Tube Exhaust

**NOTE:** All component dimensions given in U.S. inches  
1 inch = 25.4 mm

# REPAIR PARTS

TRACTOR - MODEL NO. YTH151 (96011011600), PRODUCT NO. 960 11 01-16  
SEAT ASSEMBLY

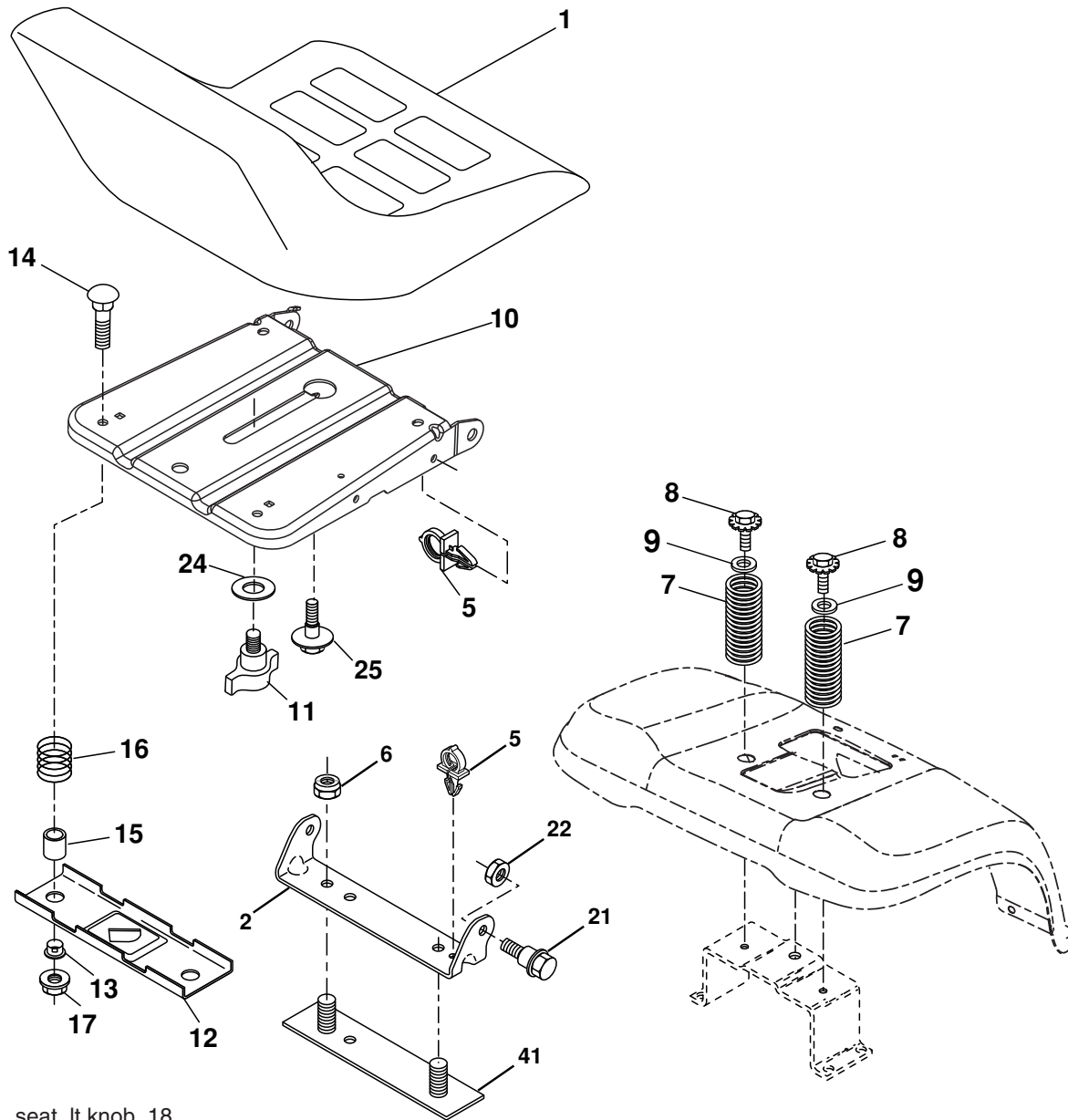

seat\_lt.knob\_18

KEY NO.	PART NO.	DESCRIPTION
1	532 19 01-20	Seat
2	532 14 05-51	Bracket Pivot Seat 8 720
5	532 14 50-06	Clip Push-In
6	873 80 06-00	Nut Hex w/Ins. 3/8-16 unc
7	532 12 41-81	Spring Seat Cprsn 2 250 Blk Zi
8	817 00 06-16	Screw 3/8-16 x 1-1/2 Smgml Tap/R Z
9	819 13 16-14	Washer 13/32 x 1 x 14 Ga.
10	532 19 55-30	Pan Seat
11	532 16 63-69	Knob Seat Adj. Wingnut
12	532 17 46-48	Bracket Mounting Switch
13	532 12 12-48	Bushing Snap Blk Nyl 50 Id
14	872 05 04-12	Bolt Rdhd Sqnk 1/4-20 x 1-1/2

KEY NO.	PART NO.	DESCRIPTION
15	532 13 43-00	Spacer Split 28 x 96 Yel Zinc
16	532 12 12-50	Spring Cprsn 1 27 Blk Pnt
17	532 12 39-76	Nut Lock 1/4 Lge Flg Gr. 5 Zinc
21	532 17 18-52	Bolt Shoulder 5/16-18 unc-2a Blk DA
22	873 80 05-00	Nut Hex Lock W/Ins 5/16-18
24	819 17 19-12	Washer 17/32 x 1-3/16 x 12 Ga.
25	532 12 70-18	Bolt Shoulder 5/16-18 x 62
41	532 14 06-75	Strap Asm. Fender

**NOTE:** All component dimensions given in U.S. inches.  
1 inch = 25.4 mm

# REPAIR PARTS

TRACTOR - MODEL NO. YTH151 (96011011600), PRODUCT NO. 960 11 01-16  
MOWER LIFT

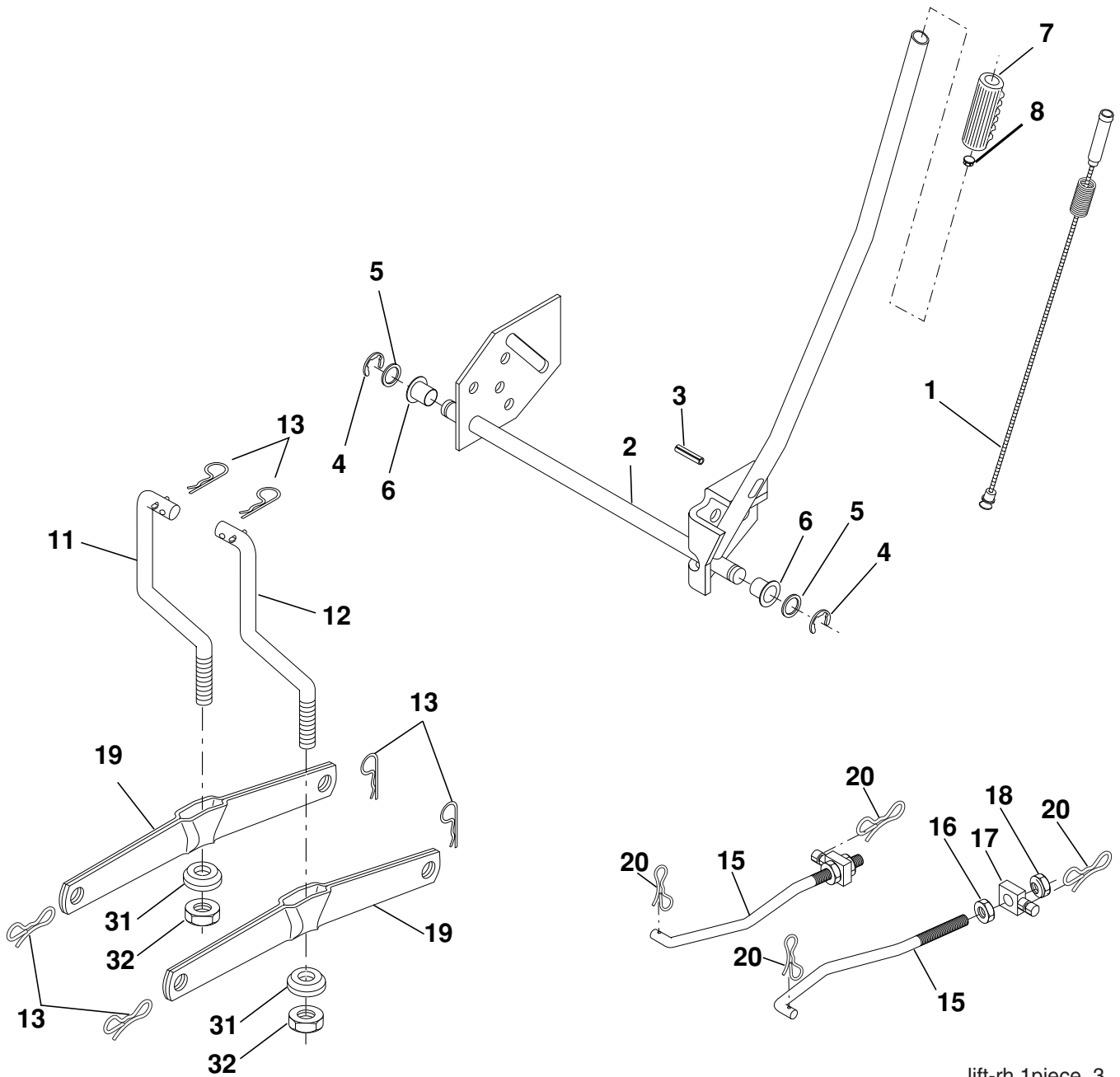

lift-rh.1piece\_3

KEY NO.	PART NO.	DESCRIPTION
1	532 15 94-60	Wire Asm Inner Sprg w/Plunger
2	532 15 94-71	Shaft Asm Lift
3	532 10 57-67	Pin Groove
4	812 00 00-02	E Ring #5133-62
5	819 21 16-21	Washer PLTD 21/32 x 1 x 21 Ga.
6	532 12 01-83	Bearing Nylon Blk 629 Id
7	532 12 56-31	Grip Handle Fluted
8	532 12 45-26	Button Plunger Black
11	532 13 98-65	Link Lift LH
12	532 13 98-66	Link Lift RH
13	532 12 46-70	Retainer Spring

KEY NO.	PART NO.	DESCRIPTION
15	532 17 32-88	Link Front
16	873 35 08-00	Nut Jam Hex 1/2-13 unc
17	532 17 56-89	Trunnion Blk Zinc
18	873 80 08-00	Nut Lock w/wsh 1/2-13 unc
19	532 13 98-68	Arm Suspension Rear
20	532 19 42-09	Pin Cotter 7/16 Bow Tie Lock
31	532 16 98-65	Bearing Pvt. Lift
32	873 54 06-00	Nut Crownlock 3/8-24

**NOTE:** All component dimensions given in U.S. inches  
1 inch = 25.4 mm



# REPAIR PARTS

TRACTOR - MODEL NO. YTH151 (96011011600), PRODUCT NO. 960 11 01-16  
MOWER DECK

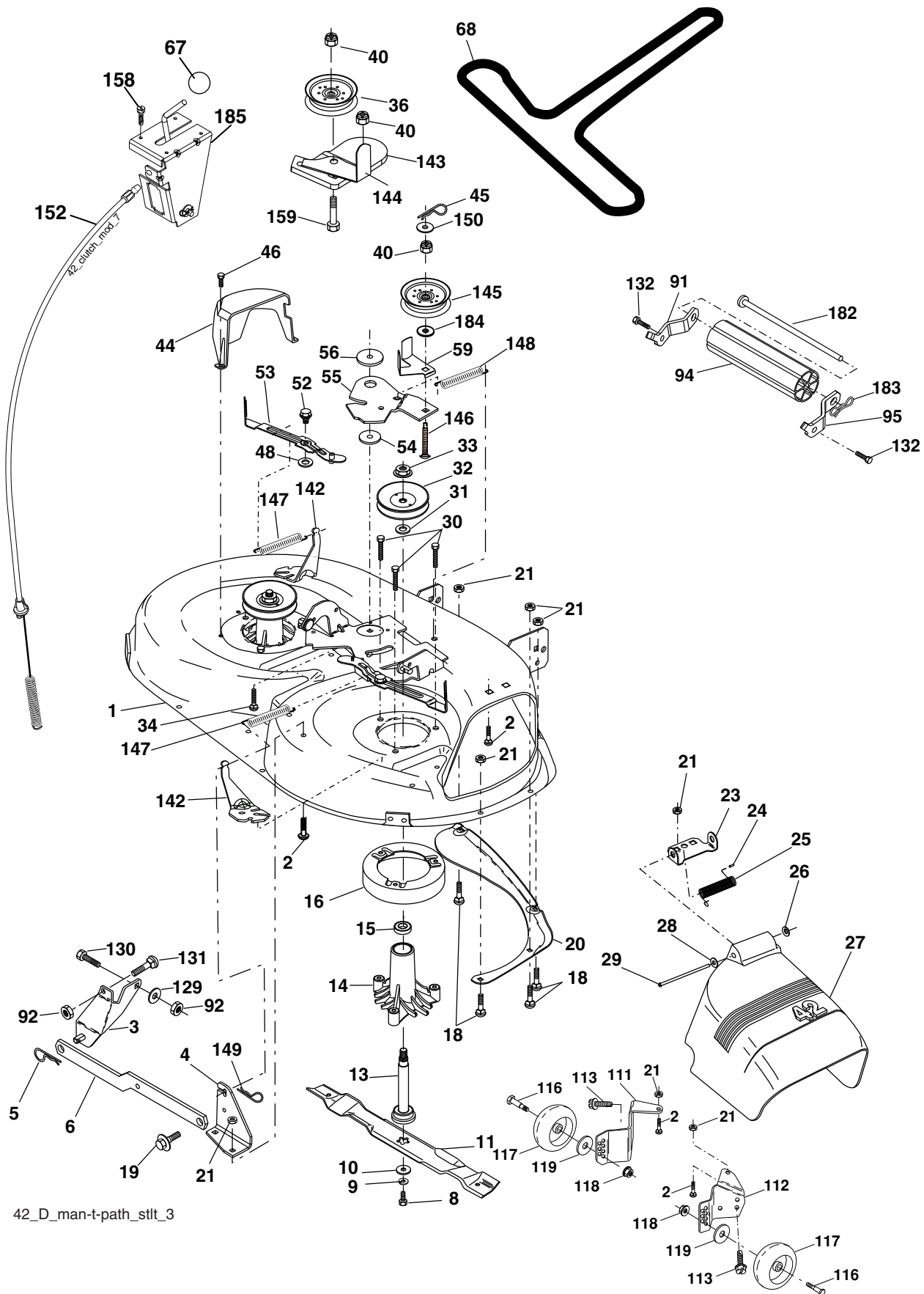

# REPAIR PARTS

**TRACTOR - MODEL NO. YTH151 (96011011600), PRODUCT NO. 960 11 01-16**  
**MOWER DECK**

KEY NO.	PART NO.	DESCRIPTION	KEY NO.	PART NO.	DESCRIPTION
1	532 16 58-92	Deck Asm MWR 42"weldment	68	532 18 02-15	V-Belt Mower 42"
2	872 14 05-06	Bolt Rdhd Sqnk 5/16-18 unc x 3/4	91	532 18 05-32	Bracket Asm Noseroller LH
3	532 13 80-17	Bracket Asm Fr Sway Bar 38/42	92	873 80 06-00	Nut Lock Hex W/Ins 3/8-16 unc
4	532 16 54-60	Bracket Asm Deck 42"sway Bar	94	532 13 22-64	Roller Nose 38 & 42
5	532 12 46-70	Retainer Spring	95	532 18 05-33	Bracket Asm Noseroller RH
6	532 17 80-24	Bar Sway Deck	111	532 17 92-92	Bracket Wheel Gauge LH 42"
8	532 85 08-57	Bolt 3/8-24 x 1.25 Gr. 8	112	532 17 92-93	Bracket Gauge Wheel RH 42"
9	810 03 06-00	Washer Lock Hvy 3/8	113	817 00 05-10	Bolt 5/16-18 Hex Wsh Hd LckSerr
10	532 14 02-96	Washer Hard Blade Mower Vented	116	532 12 48-42	Bolt Shoulder
11	532 13 89-71	Blade Mower 42"	117	532 18 86-06	Wheel Gauge
13	532 13 76-45	Shaft Asm W/lower Bearing	118	873 93 06-00	Nut Centerlock 3/8-16 unc
14	532 12 87-74	Housing Mandrel Vented	119	819 12 14-14	Washer 3/8 x 7/8 x 14 Ga.
15	532 11 04-85	Bearing Ball Mandrel	129	819 13 13-12	Washer 13/32 x 13/16 x 12 Ga.
16	532 17 44-93	Stripper Mower Vented	130	874 78 06-16	Bolt Fin Hex 3/8-16 unc x 1 Gr. 5
18	872 14 05-05	Bolt Rdhd Sqnk 5/16-18 x 5/8	131	872 14 06-08	Bolt Rdhd Sqnk 3/8-16 x 1
19	532 13 28-27	Bolt Shoulder	132	817 00 06-12	Screw 3/8-16 x .75
20	532 15 97-70	Baffle Vortex 42	142	532 16 58-90	Anchor Spring Brake Mower
21	873 68 05-00	Nut Crownlock 5/16-18 unc	143	532 15 71-09	Bracket Arm Idler 42"
23	532 17 75-63	Bracket Deflector Mower 42"	144	532 15 86-34	Keeper Belt 42" Clutch Idler
24	532 10 53-04	Cap Sleeve 80 x 112 Blk Mower	145	532 16 58-88	Pulley Idler Flat
25	532 12 37-13	Spring Torsion Deflector 2 52	146	532 17 19-77	Bolt Carriage Idler
26	532 11 04-52	Nut Push Phos & Oil	147	532 17 97-48	Spring Extension
27	532 17 18-59	Shield Deflector Mower 42" Blk	148	532 16 90-22	Spring Return Idler
28	819 11 10-16	Washer 11/32 x 5/8 x 16 Ga.	149	532 16 58-98	Retainer Spring Yellow
29	532 13 14-91	Rod Hinge 42" 6 75 Wlg	150	819 09 12-10	Washer 9/32 x 3/4 x 10 Ga.
30	532 17 39-84	Screw Thd Rolling	152	532 18 15-55	Clutch Cable 42"
31	532 18 76-90	Washer Spacer	158	817 72 04-08	Screw Hex Thd Cut 1/4-20 x 1/2
32	532 15 35-35	Pulley Mandrel 42"	159	872 14 06-14	Bolt Rdhd Sqn 3/8-16 unc x 1-3/4
33	532 40 02-34	Nut Toplock Flng	182	532 17 91-26	Rod Roller Nose Standard
34	872 11 06-12	Bolt Carr S.h 3/8-16 x 1-1/2 Gr. 5	183	532 19 42-09	Pin Cotter 7/16 Bow Tie Lock
36	532 13 14-94	Pulley Idler Flat 3 060	184	819 13 14-10	Washer 13/32 x 7/8 x 10 Ga.
40	873 90 06-00	Nut Lock Flg 3/8-16 unc	185	532 18 82-34	Head Asm Cable Clutch
44	532 14 00-88	Guard Mandrel LH Black	--	532 13 07-94	Mandrel Asm Service (Includes Housing, Shaft and Shaft Hardware Only - Pulley Not Included)
45	532 12 47-88	Spring Retainer 1" Zinc/cad	--	532 18 13-85	Replacement Deck, Complete (Std. Deck - Order separately nose roller and gauge wheel components key nos. 91, 94, 95, 132, 182, 183 and 116-119)
46	532 13 77-29	Screw Hex Thd Cut 1/4-20 x 5/8 T			
48	532 13 39-44	Washer Hardened Smaller			
52	532 13 98-88	Bolt Shoulder 5/16-18 unc Blkz			
53	532 18 49-07	Arm Asm Pad Brake			
54	532 17 85-15	Washer Hardened			
55	532 15 50-46	Arm Idler 42"mower LT/YT			
56	532 16 57-23	Spacer Retainer Mower			
59	532 14 10-43	Guard TUV Idler			
67	532 10 69-32	Knob Rd			

**NOTE:** All component dimensions given in U.S. inches  
1 inch = 25.4 mm