

CT151

Spare parts

Ersatzteile

Pièces détachées

Reserve onderdelen

Repuestos

Reservdelar

ILLUSTRATED PARTS LIST

MFG. ID NO. 96061006400

CUSTOMER CATALOG NO. CT151

PRODUCT NO. 960 61 00-64

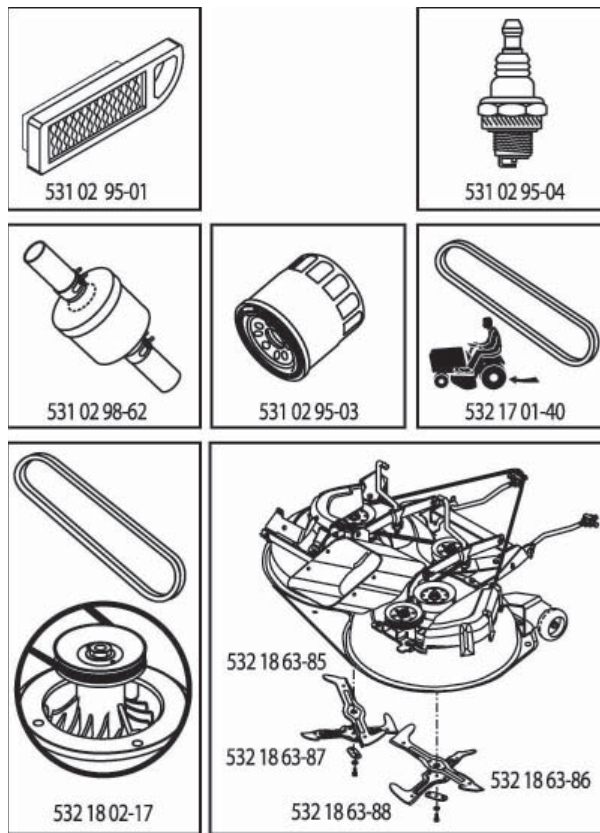

401024

TRACTOR- -MODEL NO. CT151 (96061006400) PRODUCT NO. 960 61 00-64 SCHEMATIC

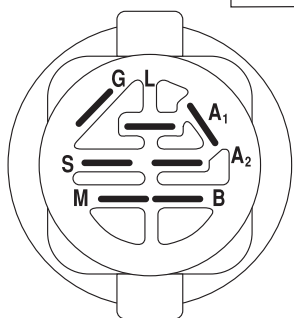
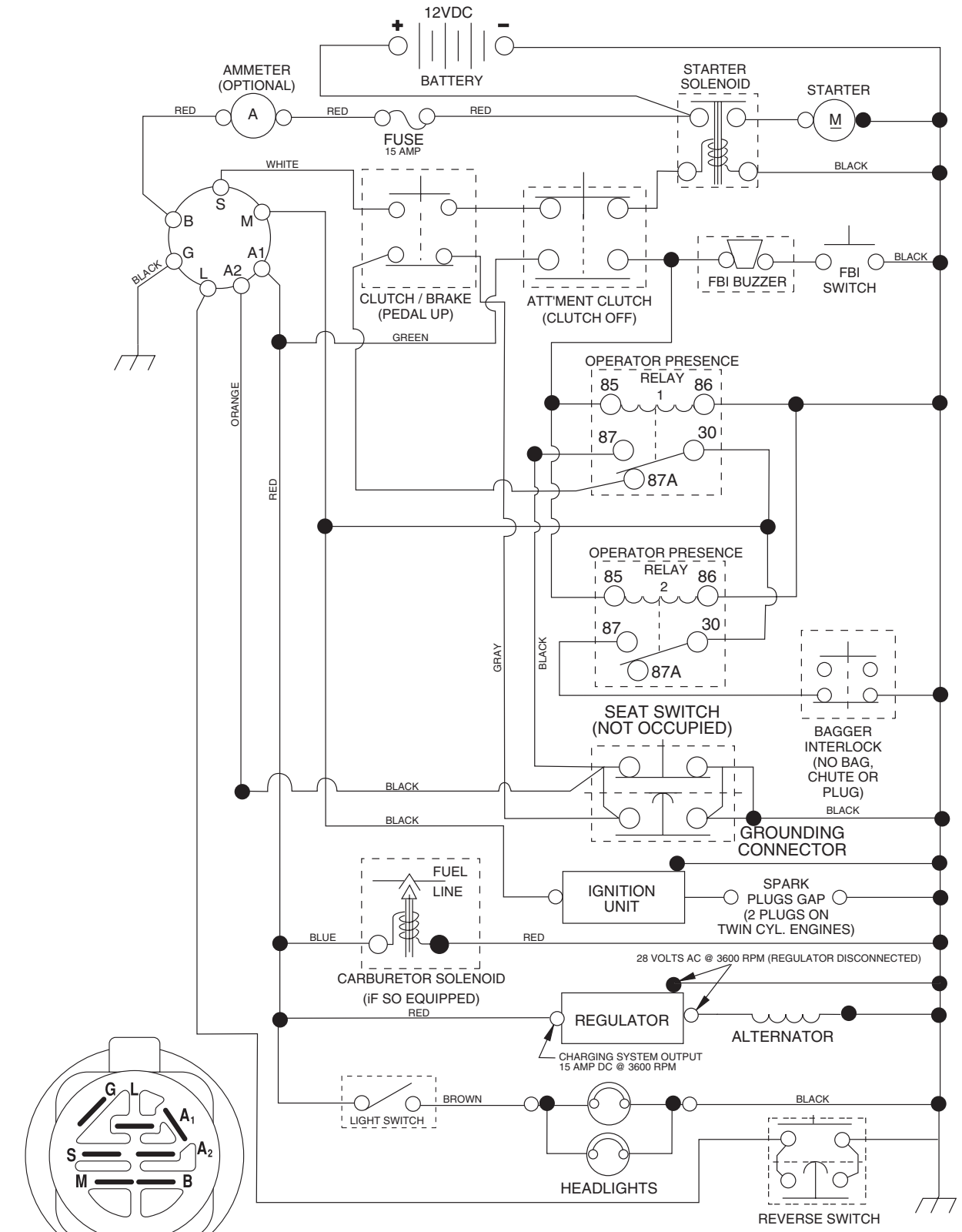

IGNITION SWITCH

POSITION	CIRCUIT "MAKE"
OFF	M+G+A1
RUN/OVERRIDE	B+A1
RUN	B+A1 L+A2
START	B + S + A1

WIRING INSULATED CLIPS

NOTE: IF WIRING INSULATED CLIPS WERE REMOVED FOR SERVICING OF UNIT, THEY SHOULD BE REPLACED TO PROPERLY SECURE YOUR WIRING.

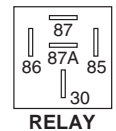

REPAIR PARTS

TRACTOR- -MODEL NO. CT151 (96061006400) PRODUCT NO. 960 61 00-64
DECALS

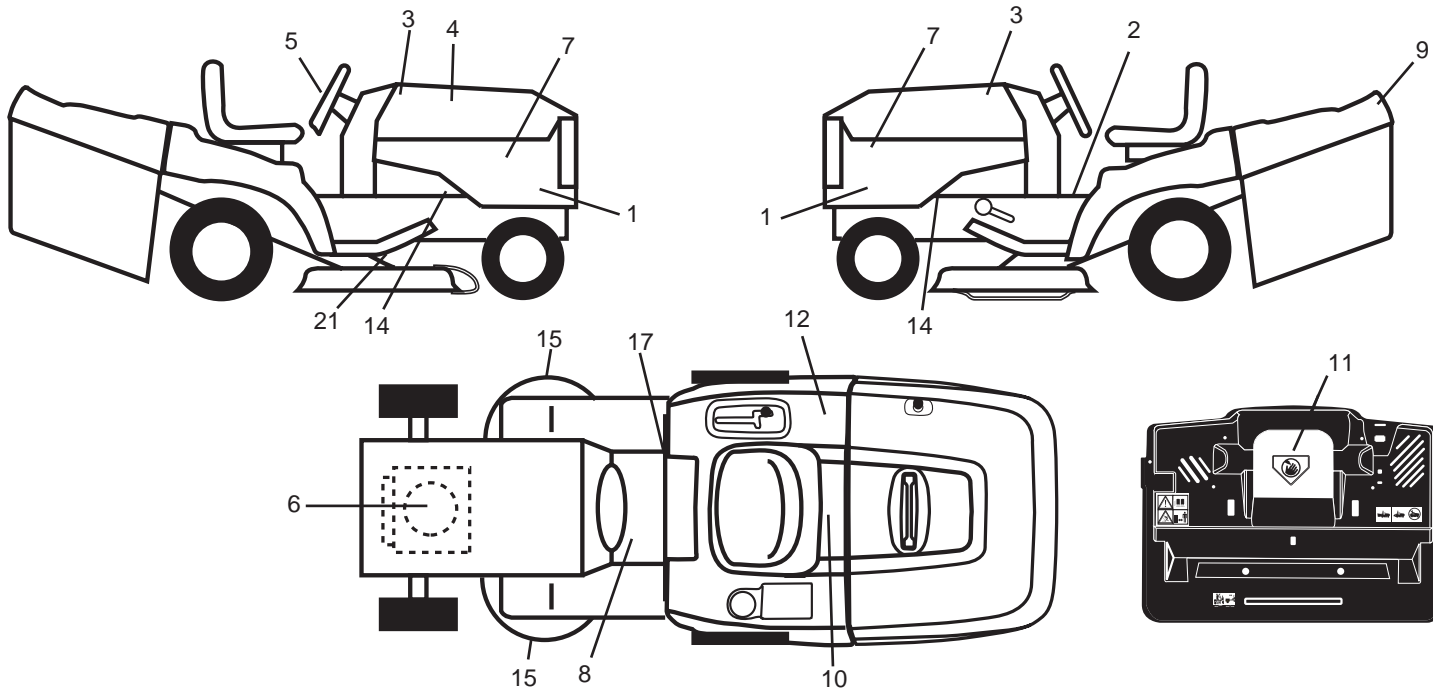

KEY NO.	PART NO.	DESCRIPTION
1	532 19 11-43	Decal Side Panel
2	532 40 03-89	Decal Warning Symbols CE
3	532 18 89-23	Decal Hood
4	532 40 10-24	Decal Replacement
5	532 18 89-25	Decal Wheel Logo
6	532 19 68-41	Decal Warning Engine Symbols
7	532 18 89-21	Decal Hood Rh/LH
8	532 15 97-37	Decal Brake/Clutch Symbol
9	532 18 89-29	Decal Fender Logo
10	532 14 50-05	Decal Bat Dan/Poi P/L Sym Wpn
11	532 18 21-66	Decal Mower Cut Finger Symbol
12	532 18 04-32	Decal Fender 100 DB/CE

KEY NO.	PART NO.	DESCRIPTION
14	532 15 97-36	Decal Chassis Hot Muffler
15	532 19 68-42	Decal Warning Cut Finger
17	532 14 08-37	Decal Saddle Brake Parking
21	532 16 62-86	Decal Deck Sch 92 CRD
--	532 13 83-11	Decal Lift Handle
--	532 18 10-91	Pad Footrest LH
--	532 18 10-90	Pad Footrest RH
--	532 40 03-79	Manual Operator's (Euro)
--	532 40 03-81	Manual Operator's (Scan)
--	532 40 14-13	Manual Operator's (EBloc)
--	532 40 14-14	Manual Operator's (Baltic)

WHEELS & TIRES

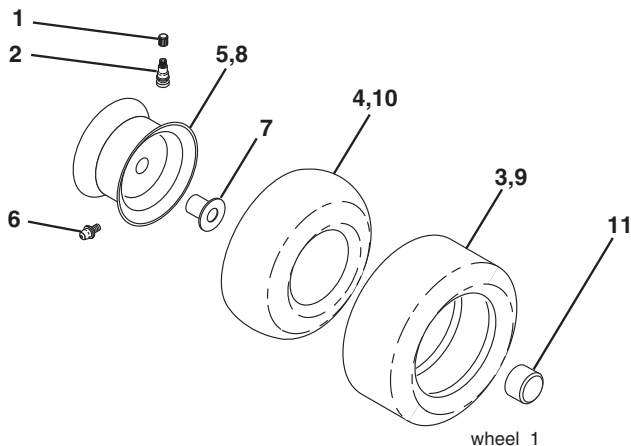

KEY NO.	PART NO.	DESCRIPTION
1	532 05 91-92	Cap Valve Tire
2	532 06 51-39	Stem Valve
3	532 10 62-22	Tire F Ts 15 x 6 0 - 6 Service
4	532 05 99-04	Tube Inner Front #35060
5	532 13 83-36	Rim Asm 6" front Service
6	532 12 49-57	Fitting Grease
7	532 12 49-59	Bearing Flange
8	532 13 83-37	Rim Asm 8" rear Service
9	532 10 62-68	Tire R Ts 18 x 9.5-8 Service
10	532 12 49-26	Tube Rear 9 5 x 8 Service
11	532 17 50-39	Cap Axle Blk 1 50 x 1 00
--	532 14 43-34	Sealant, Tire (10 oz. tube)

NOTE: All component dimensions given in U.S. inches.
1 inch = 25.4 mm

REPAIR PARTS

TRACTOR- -MODEL NO. CT151 (96061006400) PRODUCT NO. 960 61 00-64
ELECTRICAL

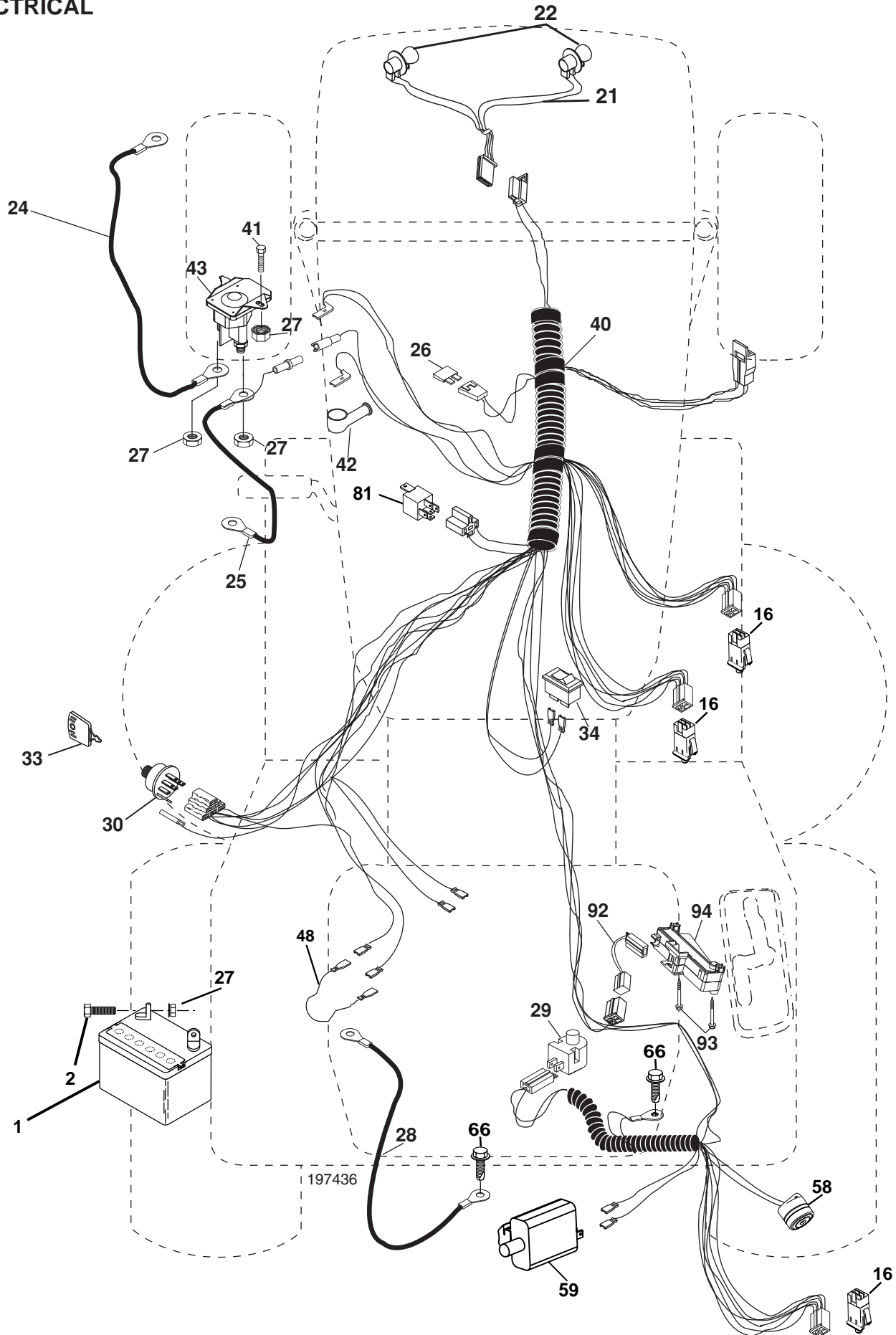

REPAIR PARTS

TRACTOR- -MODEL NO. CT151 (96061006400) PRODUCT NO. 960 61 00-64
ELECTRICAL

KEY NO.	PART NO.	DESCRIPTION
1	532 14 49-27	Battery
2	874 76 04-12	Bolt Hex Hd 1/4-20 unc x 3/4
16	532 17 61-38	Switch Interlock
21	532 17 56-88	Harness Asm Light W/4152J
22	532 00 41-52	Bulb Light #1156
24	532 12 47-80	Cable Starter 6 Ga. 11" Red
25	532 16 59-87	Cable Battery Crd 56" Red
26	532 17 51-58	Fuse
27	873 51 04-00	Nut Keps Hex 1/4-20 unc
28	532 12 77-25	Cable Ground 6 Ga. 18" Black
29	532 19 27-49	Switch Seat
30	532 19 33-50	Switch Ignition
33	532 14 04-01	Key Ign Molded
34	532 11 07-12	Switch Light
40	532 19 74-36	Harness Ign
41	871 11 04-08	Bolt Flk Fin Hex 1/4-20 unc x 1/2
42	532 13 15-63	Cover Terminal Red
43	532 19 25-07	Solenoid
48	532 14 08-44	Adapter Ammeter Rectangular
58	532 16 94-19	Buzzer Crd
59	532 18 03-79	Switch FBI CRD
66	817 49 06-08	Screw Thdrol 3/8-16 x 1/2 Ty-Tt
81	532 10 97-48	Relay Asm
92	532 19 66-15	Harness Pigtail
93	532 19 25-40	Screw Plastite 10-14 x 2.0
94	532 19 18-34	Module Reverse

NOTE: All component dimensions given in U.S. inches.
1 inch = 25.4 mm.

REPAIR PARTS

TRACTOR- -MODEL NO. CT151 (96061006400) PRODUCT NO. 960 61 00-64
CHASSIS AND ENCLOSURES

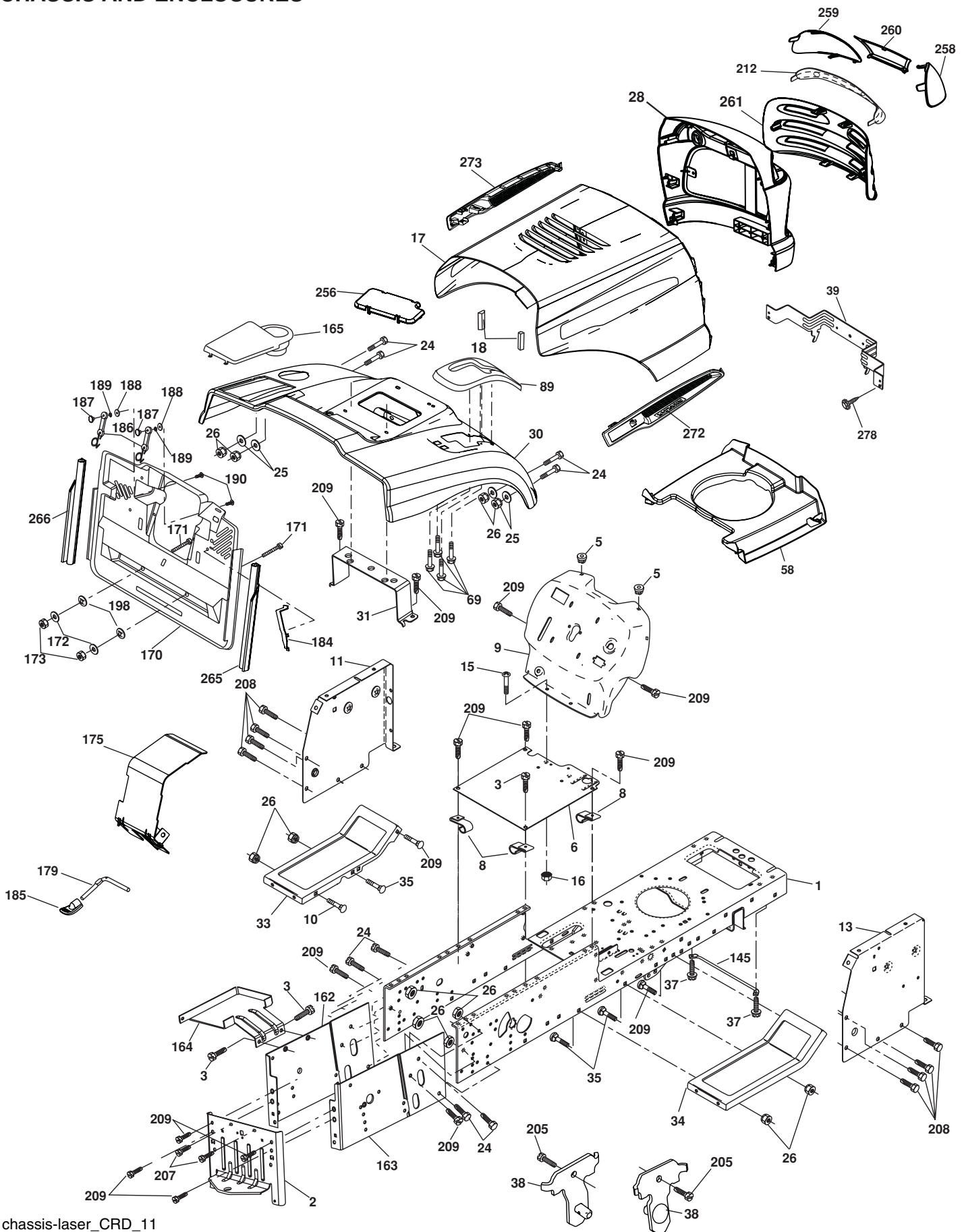

REPAIR PARTS

TRACTOR- -MODEL NO. CT151 (96061006400) PRODUCT NO. 960 61 00-64 CHASSIS AND ENCLOSURES

KEY NO.	PART NO.	DESCRIPTION	KEY NO.	PART NO.	DESCRIPTION
1	532 17 46-20	Chassis	170	532 19 94-88	Backplate CRD
2	532 18 03-84	Drawbar	171	872 14 06-20	Bolt Rdhd Sqnk 3/8-16 x 2-1/2 Gr. 5
3	817 06 06-12	Screw 3/8-16 x 3/4	172	819 13 20-16	Washer 13/32 x 1-1/4 x 16 Ga.
5	532 15 52-72	Bumper Hood/Dash	173	873 51 06-00	Nut, Keps Hex 3/8-16 unc
6	532 18 44-19	Saddle	175	532 18 82-03	Door Trap
8	532 12 64-71	Clip Insulator 13/32 Mtg. Hole	179	532 18 82-02	Rod Pivot FBI CRD
9	532 19 42-89	Dash	184	532 17 46-62	Bracket Actuator Bagger CRD
10	872 14 06-08	Bolt, Carriage 3/8-16 x 3/4	185	532 18 11-01	Knob Rod Brake Parking
11	532 17 49-96	Panel, Dash, L.H.	186	532 16 07-93	Latch Asm Mulch/Bagger
13	532 17 21-06	Panel, Asm. Dash R.H.	187	532 12 50-04	Nut Weld
15	874 18 05-12	Screw, Machine, Truss Head 5/16-18 unc x 3/4	188	819 06 12-16	Washer #10
16	873 51 05-00	Nut	189	810 07 10-00	Washer Lock #10
17	532 18 88-93	Hood	190	871 08 10-10	Screw Pan Hd Phillip 10-24 x 5/8
18	532 18 49-21	Bumper Hood	198	532 16 89-37	Nut, Push
24	874 78 06-16	Bolt	205	817 49 06-08	Screw Thdrol 3/8-16 x 1/2
25	819 13 13-12	Washer 13/32 x 13/16 x 12 Ga.	207	817 67 05-08	Screw Thdrl. 5/16-18 x 1/2
26	873 80 06-00	Nut	208	817 67 06-08	Screw Thdrol 3/8-16 x 1/2
28	532 18 35-38	Grille /Lens Asm (Includes Key Nos. 212, 258 - 261)	209	817 00 06-12	Screw Hex Wsh Thdrol 3/8-16
30	532 19 73-76	Fender	212	532 18 35-48	Insert Lens Reflect
31	532 16 51-56	Bracket, Fender Support	256	532 18 13-61	Cover Fender Rack
33	532 18 10-57	Footrest, L.H.	258	532 18 52-14	Lens RH
34	532 18 10-58	Footrest, R.H.	259	532 18 52-13	Lens LH
35	872 11 06-06	Bolt	260	532 18 52-16	Cover Lens
37	817 49 05-08	Screw Thdrol 5/16-18 x 1/2 TYT	261	532 18 52-12	Insert Grille
38	532 18 17-48	Bracket Asm Pivot Mower Rear	265	532 18 57-04	Seal RH Side Bagger
39	532 17 47-14	Bracket Pivot	266	532 18 57-03	Seal LH Side Bagger
58	532 18 71-54	Duct Air Engine	272	532 18 88-96	Vent Hood RH
69	532 14 24-32	Screw HxWsh Hi-Lo	273	532 18 88-95	Vent Hood LH
89	532 19 74-07	Console CRD 6 Sp. 418	278	532 19 16-11	Screw 10 x 3/4 Single Lead Hex
145	532 15 65-24	Rod Pivot Chassis/Hood	--	532 18 78-01	Plug Dome Plastic
162	532 18 03-82	Bracket Exten Chassis Lh CRD			
163	532 18 03-83	Bracket Exten Chassis Rh CRD			
164	532 16 56-05	Support Battery CRD			
165	532 18 11-00	Cover Battery			

NOTE: All component dimensions given in U.S. inches.
1 inch = 25.4 mm.

REPAIR PARTS

TRACTOR- -MODEL NO. CT151 (96061006400) PRODUCT NO. 960 61 00-64
DRIVE

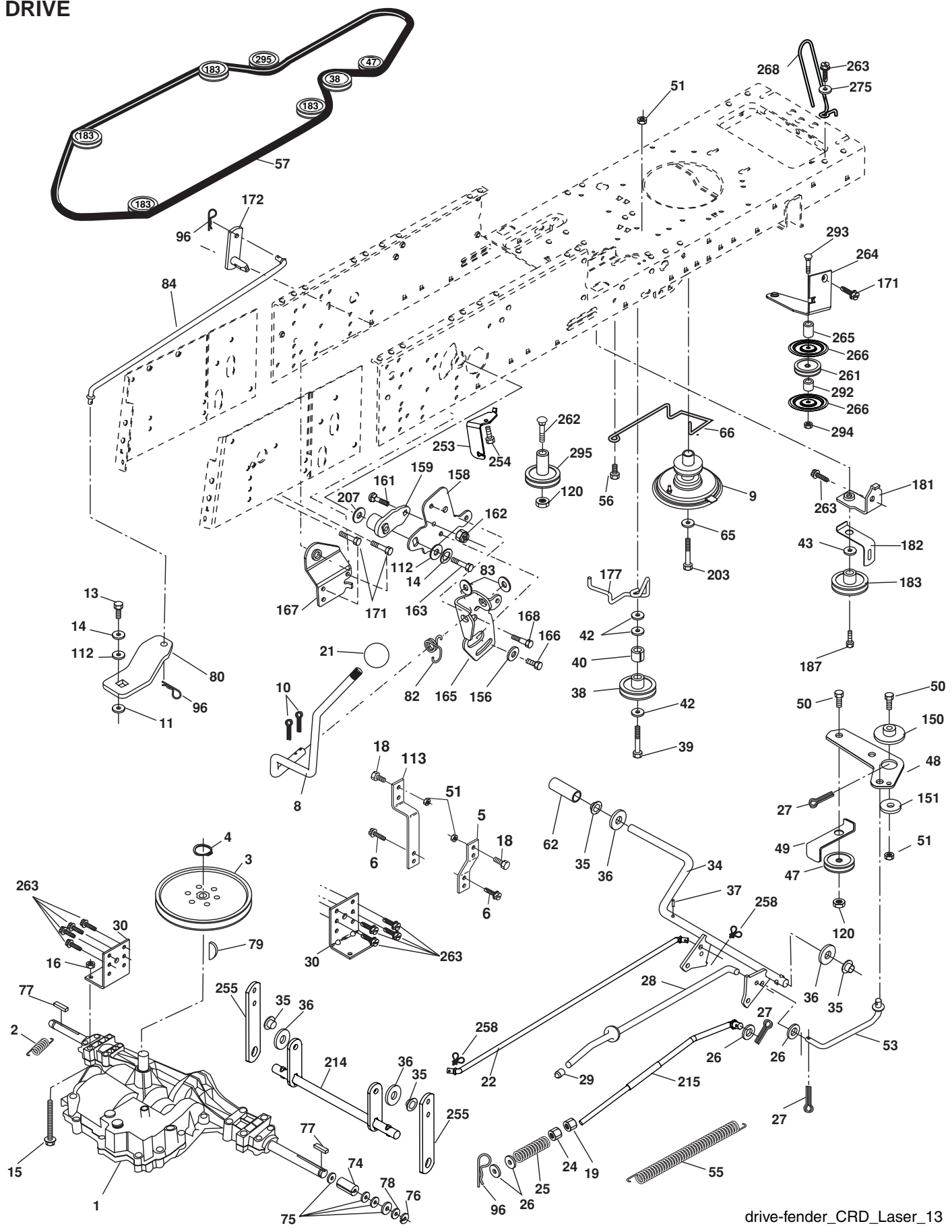

REPAIR PARTS

TRACTOR- -MODEL NO. CT151 (96061006400) PRODUCT NO. 960 61 00-64
DRIVE

KEY NO.	PART NO.	DESCRIPTION	KEY NO.	PART NO.	DESCRIPTION
1	-----	Transaxle Peerless 206-546 (Order parts from transaxle manufacturer)	78	532 12 17-48	Washer 25/32 x 1-5/8 x 16 Ga.
2	532 14 66-82	Spring Brake Return	79	532 12 50-96	Key Woodruff
3	532 16 59-99	Pulley Transaxle	80	532 14 50-90	Arm Shift PMST 20" Tires
4	812 00 00-28	Ring Retainer #5100-62	82	532 16 57-11	Spring, Torsion
5	532 12 15-20	Strap torque 30 degrees	83	819 17 12-16	Washer 17/32 x 3/4 x 16 Ga.
6	817 06 05-12	Screw 5/16-18 x 3/4	84	532 16 56-21	Link Shift CRD Pmst 18" Tires
8	532 19 27-06	Rod Shift	96	532 12 47-88	Spring, Retainer 1"
9	532 19 81-44	Clutch Noram	112	819 09 12-10	Washer 9/32 x 3/4 x 10 Ga.
10	876 02 04-16	Pin, Cotter 1/8 x 1	120	873 90 06-00	Nut Lock Flg. 3/8-16 unc
11	532 10 57-01	Washer Plate Shf .3888 sq hole	150	532 16 58-50	Bushing, Bellcrank Grnd Dr
13	874 55 04-12	Bolt 1/4-28 unf Gr. 8 w/patch	151	819 13 32-10	Washer 13/32 x 2 x 10 Ga.
14	810 04 04-00	Washer, Lock Hvy Helical	156	532 16 60-02	Washer Srrd 5/16 ID x 1.125
15	874 49 05-44	Bolt Hex Flghd 5/16-18 Gr. 5	158	532 16 55-89	Bracket Shift Mount
16	873 80 05-00	Nut, Lock Hex w/lms 5/16-18 unc	159	532 18 39-00	Hub Shift
18	874 78 06-16	Bolt Hex 3/8-16 unc x 1 Gr. 5	161	872 14 04-06	Bolt Rdhd Sqnk 1/4-20 x 3/4 Gr 5
19	873 80 06-00	Nut, Lock Hex w/Wsh 3/8-16 unc	162	873 68 04-00	Nut Crownlock 1/4-20 unc
21	532 12 12-74	Knob Duckhead	163	874 78 04-16	Bolt Hex Fin 1/4-20 unc x 1 Gr 5
22	532 17 56-07	Rod, Brake CRD	165	532 16 56-23	Bracket Pivot Lever
24	873 35 06-00	Nut	166	817 49 05-10	Screw 5/16-18 x 5/8
25	532 10 68-88	Spring, Rod, Brake	167	532 16 55-88	Bracket Support Shift CRD
26	819 13 13-16	Washer 13/32 x 13/16 x 16 Ga.	168	532 16 54-92	Bolt Shoulder 5/16-18 x .561
27	876 02 04-12	Pin, Cotter 1/8 x 3/4	171	817 49 06-08	Screw Thdrol 3/8-16 x 1/2 Ty-Tt
28	532 17 57-65	Rod, Parking Brake	172	532 16 56-35	Shaft Asm Shift Front CRD PMST
29	532 07 16-73	Cap Brake Parking	177	532 16 59-32	Keeper Flat Idler 3.06" CRD
30	532 17 49-73	Bracket, Mfg. Transaxle	181	532 18 02-11	Bracket Idler Ground Drive CRD
34	532 17 55-78	Shaft, Asm Pedal Foot	182	532 18 26-82	Keeper Belt 2.5" Od V-Idler CRD
35	532 12 01-83	Bearing, Nylon	183	532 19 95-32	Pulley V-Idler
36	819 21 16-16	Washer 21/32 x 1 x 16 Ga.	187	817 58 05-20	Screw 5/16-18 x 1.25
37	532 12 49-63	Pin, Roll 3/16 x 1"	203	871 17 07-80	Bolt Hex 7/16-20 x 5
38	532 16 59-36	Pulley, Flat	207	532 16 98-45	Washer Nylon Rear
39	874 76 06-44	Bolt Fin Hex 3/8-16 unc x 2-3/4	214	532 17 56-09	Shaft Asm Blade
40	532 12 49-65	Spacer, Split 395 x 59 Bzp	215	532 19 95-80	Rod Brake Secondary
42	819 13 13-12	Washer 13/32 x 13/16 x 12 Ga.	253	532 17 50-28	Bracket Cable Chassis
43	819 11 10-12	Washer 11/32 x 5/8 x 12 Ga.	254	817 00 06-16	Screw 3/8-16 x 1
47	532 12 77-83	Pulley, Idler, V Groove Plasitc	255	532 17 56-08	Brace Shaft Brake Mtg.
48	532 15 44-07	Bellcrank Clutch Grnd Drv	258	532 17 80-62	Clip Retainer
49	532 12 32-05	Retainer, Belt Style Spring	261	532 13 14-94	Pulley Idler
50	872 11 06-12	Bolt 3/8-16 unc x 1-1/2	263	817 00 06-12	Screw 3/8-16 x 3/4
51	873 68 06-00	Nut, Crownlock 3/8-16 unc	262	872 11 06-22	Bolt Rdhd 3/8-16 unc x 2-3/4 Gr.5
53	532 19 96-52	Link, Clutch 7.66	264	532 17 76-08	Bracket Clutch Mtg.
55	532 10 57-09	Spring, Return, Clutch	265	532 18 20-13	Spacer Idler Chassis
56	817 06 06-20	Screw 3/8-16 x 1-1/4	266	532 18 20-61	Shield Idler Mower
57	532 16 56-31	V-Belt Kev PMST CRD	268	532 18 24-02	Guard Muffler RH
62	532 12 35-33	Cover, Pedal	275	819 13 16-14	Washer 13/32 x 1 x 14 Ga.
65	810 04 07-00	Washer	292	532 40 02-71	Spacer
66	532 15 47-78	Keeper, Belt Engine F-Proof	293	872 14 06-28	Bolt Rdhd Sqnk 3/8-16 x 3-1/2
74	532 13 70-57	Spacer Axle	294	532 19 70-33	Nut Jam 3/8-16
75	532 12 17-49	Washer 25/32 x 1-1/4 x 16 Ga.	295	532 17 91-14	Pulley Idler
76	812 00 00-01	Ring, E			
77	532 12 35-83	Key, Square			

NOTE: All component dimensions given in U.S. inches
1 inch = 25.4 mm

REPAIR PARTS

TRACTOR- -MODEL NO. CT151 (96061006400) PRODUCT NO. 960 61 00-64
STEERING ASSEMBLY

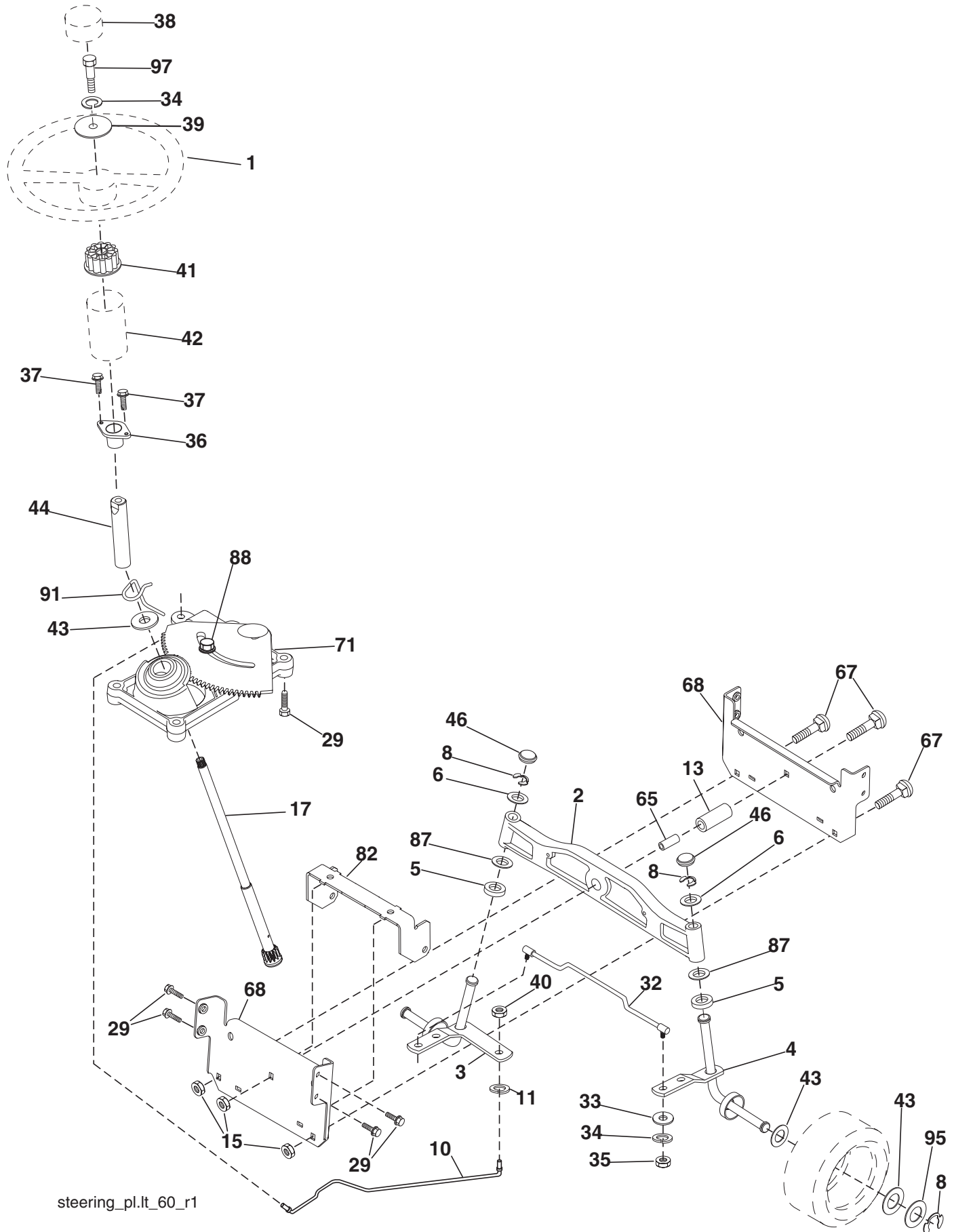

REPAIR PARTS

TRACTOR- -MODEL NO. CT151 (96061006400) PRODUCT NO. 960 61 00-64
STEERING ASSEMBLY

KEY NO.	PART NO.	DESCRIPTION
1	532 19 36-51	Steering Wheel
2	532 18 47-06	Axle Asm Cast Iron Lt
3	532 16 98-40	Spindle Assembly, L.H.
4	532 16 98-39	Spindle Assembly, R.H.
5	532 12 49-31	Bearing, Race, Thrust, Hardened
6	532 12 17-48	Washer 25/32 x 1-5/8 x 16 Ga.
8	812 00 00-29	Ring, Klip
10	532 17 51-21	Link, Drag
11	810 04 06-00	Washer, Lock
13	532 13 65-18	Spacer Brg Axle Front
15	532 14 52-12	Nut Hex Flange Lock
17	532 19 07-53	Shaft, Steering
29	817 00 06-12	Screw 3/8-16 x 3/4
32	532 17 01-62	Rod, Tie
33	819 11 12-16	Washer 11/32 x 3/4 x 16 Ga.
34	810 04 05-00	Washer Lock Hvy Hlcl Spr 5/16
35	873 54 05-00	Crownlock Nut 5/16-24 unf 3847
36	532 15 50-99	Bushing, Steering
37	532 15 29-27	Screw TT #10-32 x 5 x 3/8 Flange
38	532 19 36-52	Cap Wheel Steering
39	819 11 38-12	Washer 11/32 ID x 2- 3/8 OD x 12 Ga.
40	873 54 06-00	Nut Lock 3/8-24
41	532 18 67-37	Adaptor, Steering Wheel
42	532 16 96-34	Boot, Steering Dash P/L Mtl
43	532 12 17-49	Washer 25/32 x 1-1/4 x 16 Ga.
44	532 19 07-52	Extension Steering Shaft
46	532 12 12-32	Cap, Spindle
65	532 16 03-67	Spacer Brace Axle
67	872 11 06-18	Bolt Rdhd Sqnk 3/8-16 x 2-1/4
68	532 16 98-27	Brace Axle
71	532 17 51-46	Steering Asm.
82	532 19 99-78	Bracket Susp Chassis Front
87	532 17 39-66	Washer Flat .781 x 1 1/2 x .14
88	532 17 51-18	Bolt Shoulder 7/16-20 unc
91	532 17 55-53	Clip Steering
95	532 18 89-67	Washer
97	874 78 05-64	Bolt 5/16-18 unc x 4" L. Gr. 5

NOTE: All component dimensions given in U.S. inches.
1 inch = 25.4 mm.

REPAIR PARTS

TRACTOR- -MODEL NO. CT151 (96061006400) PRODUCT NO. 960 61 00-64
ENGINE

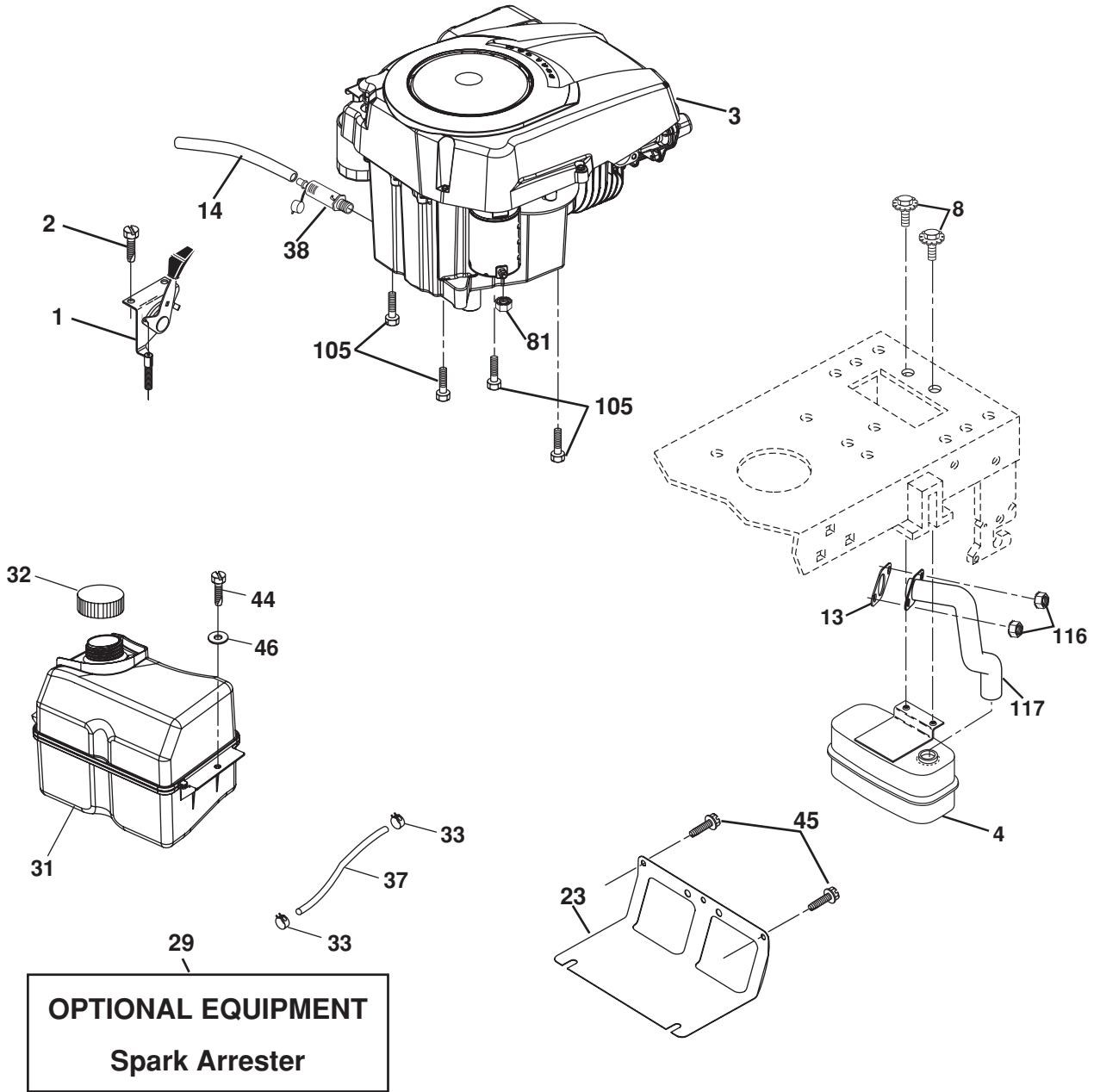

engine-kohler_42

KEY NO.	PART NO.	DESCRIPTION
1	532 17 08-05	Control Throt /Ch Flag
2	817 72 04-08	Screw Hex Thd Cut 1/4-20 x 1/2
3	-----	Engine Kohler SV470 (Order Parts from Engine Manufacturer)
4	532 18 86-55	Muffler Exhaust
8	532 17 18-77	Bolt 5/16-18 x 3/4
13	532 18 59-09	Gasket
14	532 14 84-56	Tube Drain Oil Easy
23	532 16 98-37	Shield Browning/Debris Guard
29	532 13 71-80	Arrestor Spark
31	532 18 55-34	Tank Fuel
32	532 19 77-25	Cap Asm Fule Top
33	532 12 34-87	Clamp Hose Blk

KEY NO.	PART NO.	DESCRIPTION
37	532 13 70-40	Line Fuel 20"
38	532 18 16-54	Plug Drain Oil Easy
44	817 67 04-12	Screw Hexwsh Thdrol 1/4-20 x 3/4
45	817 00 06-12	Screw Hexwsh Thdr 3/8-16 x 3/4
46	819 09 14-16	Washer 9/32 x 7/8 x 16ga
81	873 51 04-00	Nut Keps 1/4-20 unc
105	817 12 06-16	Screw 3/8-16 x 1
116	532 18 43-62	Nut Hex Flange Toplock M8-1.25
117	532 18 86-54	Tube Exhaust

NOTE: All component dimensions given in U.S. inches.
1 inch = 25.4 mm

REPAIR PARTS

TRACTOR- -MODEL NO. CT151 (96061006400) PRODUCT NO. 960 61 00-64
SEAT ASSEMBLY

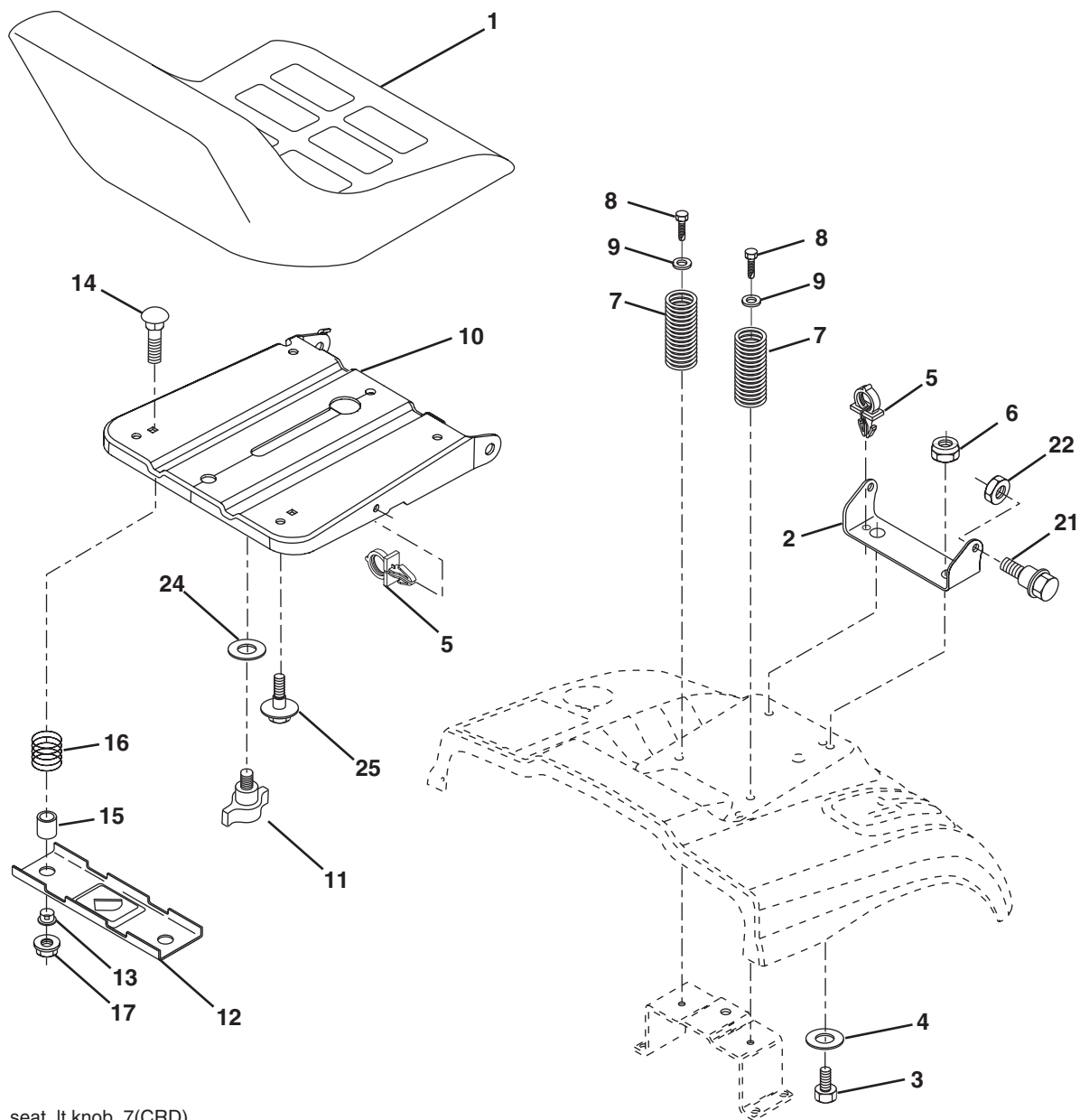

seat_lt.knob_7(CRD)

KEY NO.	PART NO.	DESCRIPTION	KEY NO.	PART NO.	DESCRIPTION
1	532 19 01-20	Seat	13	532 12 12-48	Bushing Snap Blk Nyl 50 Id
2	532 14 05-51	Bracket Pnt Pivot Seat (blk)	14	872 05 04-12	Bolt Rdhd Sht Nk 1/4-20 x 1-1/2
3	871 11 06-16	Bolt Fin Hex 3/8-16 x 1	15	532 13 43-00	Spacer Split
4	819 13 16-10	Washer Flat 13/32 x 1 x 10 Ga.	16	532 12 12-50	Spring Cprsn Plate SW 1.310 Ga.
5	532 14 50-06	Clip Push In Hinged	17	532 12 39-76	Nut Lock 1/4 Lge Flg Gr 5 Zinc
6	873 80 06-00	Nut Lock Hx w/Ins. 3/8-16	21	532 17 18-52	Bolt Shoulder 5/16-18 unc-2A
7	532 12 41-81	Spring Seat Cprsn 2 250 Blk Zi	22	873 80 05-00	Nut Hex Lock w/Ins 5/16-18
8	817 00 06-16	Screw 3/8-16 x 1-1/2	24	819 17 19-12	Washer 17/32 x 1-3/16 x 12 Ga.
9	819 13 16-14	Washer 13/32 x 1 x 14 Ga.	25	532 12 70-18	Bolt Shoulder 5/16-18 x 62
10	532 19 55-30	Pan Pnt Seat			
11	532 16 63-69	Knob Seat Adj. Wingnut			
12	532 17 46-48	Bracket Pnt Mounting Switch			

NOTE: All component dimensions given in U.S. inches.
1 inch = 25.4 mm

REPAIR PARTS

TRACTOR- -MODEL NO. CT151 (96061006400) PRODUCT NO. 960 61 00-64
MOWER LIFT

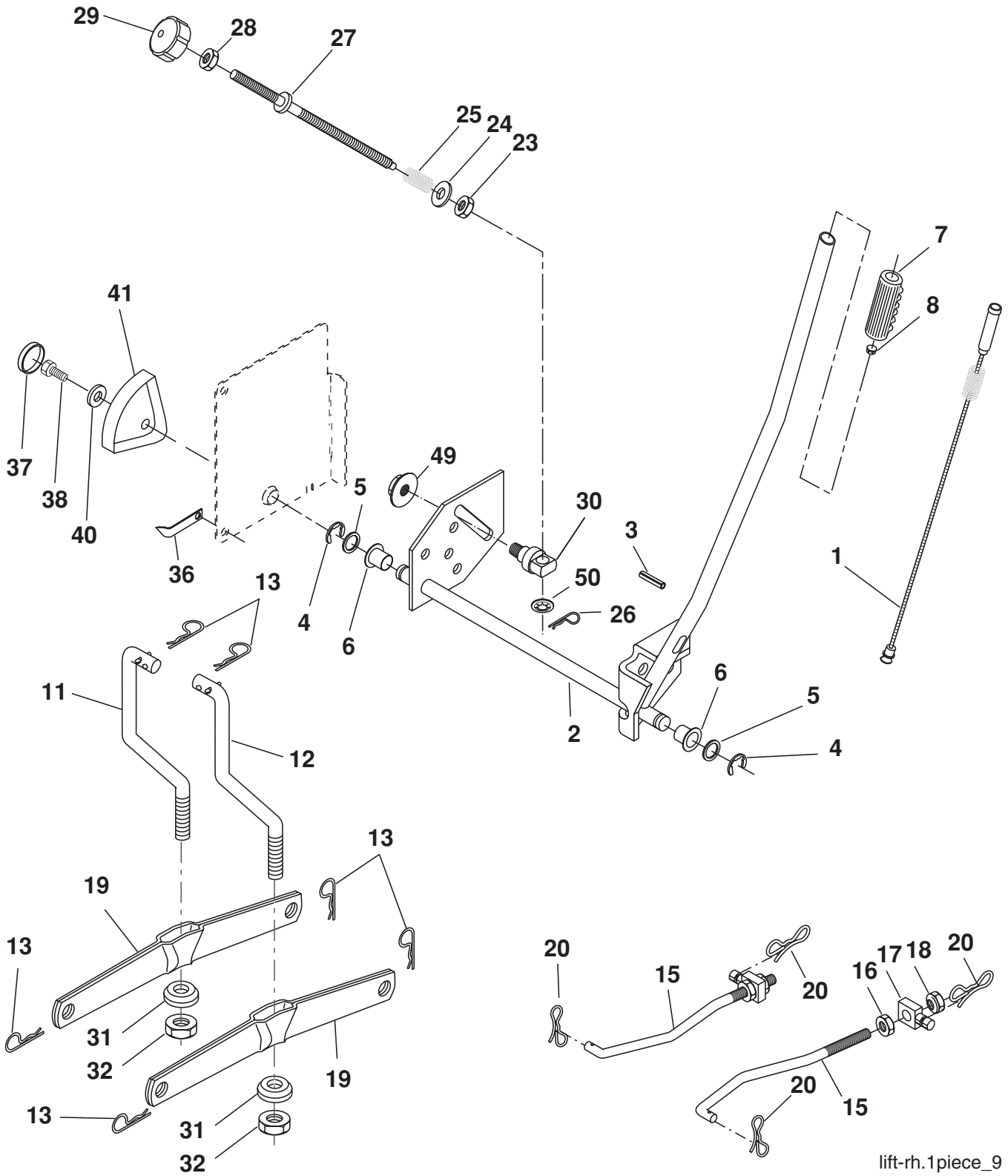

lift-rh.1piece_9

REPAIR PARTS

TRACTOR- -MODEL NO. CT151 (96061006400) PRODUCT NO. 960 61 00-64
MOWER LIFT

KEY NO.	PART NO.	DESCRIPTION
1	532 15 94-60	Washer Asm Inner Spring W/Plunger
2	532 15 94-71	Shaft Asm. Lift
3	532 10 57-67	Pin Groove
4	812 00 00-02	E Ring #5133-62
5	819 21 16-21	Washer 21/32 x 1 x 21 Ga.
6	532 12 01-83	Bearing Nylon
7	532 12 56-31	Grip Handle
8	532 12 45-26	Button Plunger Black
11	532 16 58-29	Link Lift L.H.
12	532 16 58-31	Link Lift R.H.
13	532 12 46-70	Retainer Spring
15	532 17 32-88	Link Front
16	873 35 08-00	Nut Jam Hex 1/2-13 unc
17	532 17 56-89	Trunnion
18	873 80 08-00	Nut Lock W/Wsh 1/2-13 unc
19	532 13 98-68	Arm Suspension Mower
20	532 19 42-09	Pin Cotter 7/16 Bow Tie Lock
23	532 11 08-07	Nut Special
24	819 13 10-16	Washer 13/32 x 5/8 x 16 Ga.
25	532 12 48-74	Spring 2-1/8
26	532 16 94-84	Retainer Clip
27	532 12 69-71	Rod Adj Lift Zinc
28	873 35 06-00	Nut Hex Jam 3/8-16 unc
29	532 13 80-57	Knob Inf 3/8-16 unc
30	532 15 02-33	Trunnion Infin Height
31	532 16 98-65	Bearing, Pvt. Lift.
32	873 54 06-00	Nut Crownlock 3/8-24
36	532 15 50-97	Pointer Height Indicator
37	532 12 39-35	Plug Hole Blk
38	817 06 05-16	Screw 5/16-18 x 1
40	819 11 24-10	Washer 11/32 x 1-1/2 x 10 Ga.
41	532 12 39-34	Scale Ind Height Blk
49	532 14 52-12	Nut Hex flange lock
50	532 11 04-52	Nut Push Phos &Oil

NOTE: All component dimensions given in U.S. inches.
1 inch = 25.4 mm

REPAIR PARTS

TRACTOR- -MODEL NO. CT151 (96061006400) PRODUCT NO. 960 61 00-64
MOWER

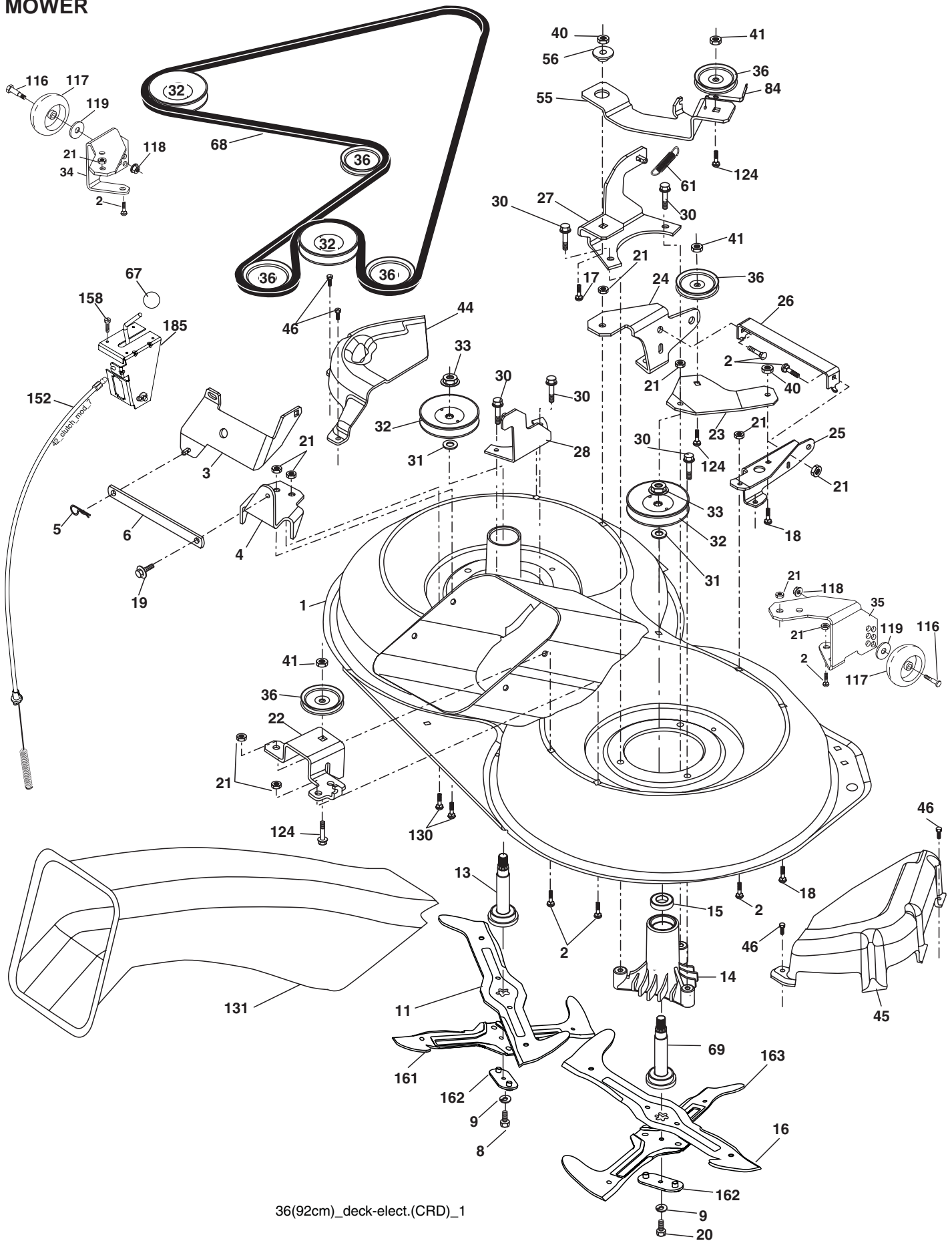

REPAIR PARTS

TRACTOR- -MODEL NO. CT151 (96061006400) PRODUCT NO. 960 61 00-64
MOWER

KEY NO.	PART NO.	DESCRIPTION	KEY NO.	PART NO.	DESCRIPTION
1	532 40 01-08	Housing Asm. Mower 92 CRD	41	873 90 06-00	Nut Lock Flg. 3/8-16 unc
2	872 14 05-06	Bolt Rdhd Sqnk 5/16-18 unc x 3/4	44	532 17 55-38	Cover Mandrel Lh 92 CRD
3	532 16 55-69	Bracket Asm. S-Bar Chass 92 CRD	45	532 17 55-39	Cover Mandrel Rh 92 CRD
4	532 16 55-58	Bracket Bar Sway Deck 92 CRD	46	532 13 77-29	Screw Thd Roll 1/4-20 x 5/8
5	532 12 46-70	Retainer Spring	55	532 19 94-98	Arm Idler 92 CRD
6	532 16 55-57	Bar Sway 92 CRD	56	532 16 57-23	Spacer Retainer Mower
8	532 18 17-12	Bolt 3/8-24 x 1.25 Gr. 8 Patched	61	532 19 94-86	Spring Tension Belt
9	810 03 06-00	Washer Lock Hvy 3/8 Unplated	67	532 10 69-32	Knob Rd 3/8-16 Plstc Thds Blk
11	532 18 63-85	Blade 3-1 Lh 92 CRD	68	532 40 20-08	Hex-Belt 92 Mower
13	532 13 76-45	Shaft Asm. W/Lower Bearing	69	532 16 54-82	Shaft Asm W/Lwr Brg Rh Thd CRD
14	532 12 87-74	Housing Mandrel Vented (Machd)	84	532 15 60-85	Keeper Belt Idler
15	532 11 04-85	Bearing Ball Mandrel	116	532 18 42-19	Bolt Shoulder
16	532 18 63-86	Blade 3-1 Rh 92 CRD	117	532 17 48-73	Wheel Gage
17	872 14 06-10	Bolt Carriage 3/8-16 x 1-1/4	118	873 93 06-00	Nut Centerlock 3/8-16 unc
18	872 11 06-06	Bolt Rdhd Sqnk 3/8-16 x 3/4	119	819 12 14-14	Washer 3/8 x 7/8 x 14 Ga.
19	532 13 28-27	Bolt Shoulder 5/16-18 Thd Form	124	872 11 06-12	Bolt Carr Sh 3/8-16 x 1-1/2 Gr. 5
20	532 18 17-13	Bolt 3/8-24 x 1.25 Gr. 8 Pch Lhthd	130	872 11 05-06	Bolt Rdhdsqnk 5/16-18 unc x 3/4
21	873 68 05-00	Nut Crown Lock 5/16-18	131	532 16 56-61	Chute Bagger CRD 92cm
22	532 19 95-90	Bracket Idler Sprt 92 CRD	152	532 17 60-74	Cable Clutch CRD
23	532 16 54-46	Bracket Idler Sprt RF 92 CRD	158	817 72 04-08	Screw Hex Thd Cut 1/4-20 x 1/2
24	532 16 52-42	Bracket Suspension LF 92 CRD	161	532 18 63-87	Blade Cross LH 92
25	532 16 52-44	Bracket Suspension RF 92 CRD	162	532 18 08-78	Adapter Blade Cross
26	532 40 01-10	Brace Susp Frt CRD	163	532 18 63-88	Blade Cross RH 92
27	532 16 55-68	Bracket Asm. Susp RR 92 CRD	185	532 18 82-34	Head Asm. Cable Clutch
28	532 16 55-67	Bracket Asm. Susp LR 92 CRD	--	532 18 18-57	Mandrel Asm Service
30	532 17 39-84	Screw Thd Rolling	--	532 18 18-58	Mandrel Asm CRD Lh Threads SVC
31	532 18 76-90	Washer Spacer Mower Vented	--	532 40 03-11	Replacement Mower, Complete (Std. Deck - Order separately guage wheel components key nos. 116 - 119)
32	532 17 57-07	Mandrel Pulleys			
33	532 40 02-34	Nut Flg Top Lock			
34	532 40 01-07	Bracket Gauge Wheel Lf 92 CRD			
35	532 40 01-06	Bracket Gauge Wheel Rf 92 CRD			
36	532 14 67-63	Pulley Idler V-Groove Dim 4.25			
40	873 68 06-00	Nut Crownlock 3/8-16 unc			

NOTE: All component dimensions given in U.S. inches
1 inch = 25.4 mm

REPAIR PARTS

TRACTOR- -MODEL NO. CT151 (96061006400) PRODUCT NO. 960 61 00-64
BAGGER

KEY NO.	PART NO.	DESCRIPTION
1	532 16 52-49	Tube Handle Bagger CRD
3	532 12 39-76	Nut Lock 1/4 Lge Flg Gr. 5 Zinc
4	532 16 99-16	Handle Bagger w/Lvrs Blk CRD
5	874 98 10-24	Screw Pan Head #10-24 x 1.50 Blk
6	874 98 10-32	Screw Pan Hd
7	873 40 10-00	Nut Wiz Lock Hex Serr/Hd 10-24
8	532 18 10-95	Cover Bagger CRD MS422
9	872 14 04-18	Bolt Carriage 1/4-20 x 2.25d x Gr. 5
10	532 18 12-82	Tube Support Bagger CRD
11	532 16 57-19	Bracket Support Upper Bag CRD
12	532 18 88-48	Bracket Pivotn Lh
14	874 52 06-36	Bolt Carr.
16	873 90 06-00	Nut Lock Flg. 3/8-16 unc
15	532 12 46-70	Retainer Spring
17	872 14 05-06	Bolt Rdhd Sht Sqnk 5/16 -18 unc x 3/4
19	873 90 05-00	Nut Lock Hexflange 5/16-18
20	532 18 88-47	Bracket Pivot Rh
21	532 19 38-38	Bag Asm CRD
22	532 16 57-81	Bracket Side Bagger CRD
24	532 16 57-83	Tube Pivot Bagger CRD
25	532 19 37-05	Tube Front Bagger CRD
28	532 16 57-87	Grip Handle Black
31	532 16 94-84	Retainer Clip
32	532 12 68-75	Rivet Rd Hd Drilled 3/8 Dia
33	532 16 55-71	Plug Mulcher 92 CRD
34	532 16 55-70	Handle Mulcher 92/107 CRD
35	532 16 55-72	Pin Mulcher 92/107 CRD
36	819 13 20-12	Washer 13/32 x 1-1/4 x 12 Ga.
37	532 17 54-01	Plug Support Bagger CRD
38	872 01 05-20	Bolt 5/16-18 x 2-1/2
39	532 18 09-85	Seal 37"
41	532 16 96-83	Bracket Vert Adj Bagger CRD
43	532 17 40-83	Plug Tubing
44	532 19 33-12	Pin Clevis
46	872 11 05-10	Bolt Carr. 5/16-18 x 1-1/4 Gr.5
47	532 19 37-04	Tube Upper Bagger
49	532 19 33-05	Bar Spreader
50	873 80 05-00	Nut Lock Thx w/Ins. 5/16-18 unc
51	532 19 99-03	Latch Spring Bagger
53	873 51 04-00	Nut Keps Hex 1/4-20 unc
54	872 14 04-06	Bolt Rdhd Sqnk 1/4-20 x 3/4 Gr. 5

NOTE: All component dimensions given in U.S. inches
1 inch = 25.4 mm