

Ride Mower

YTH2454T

917.279220

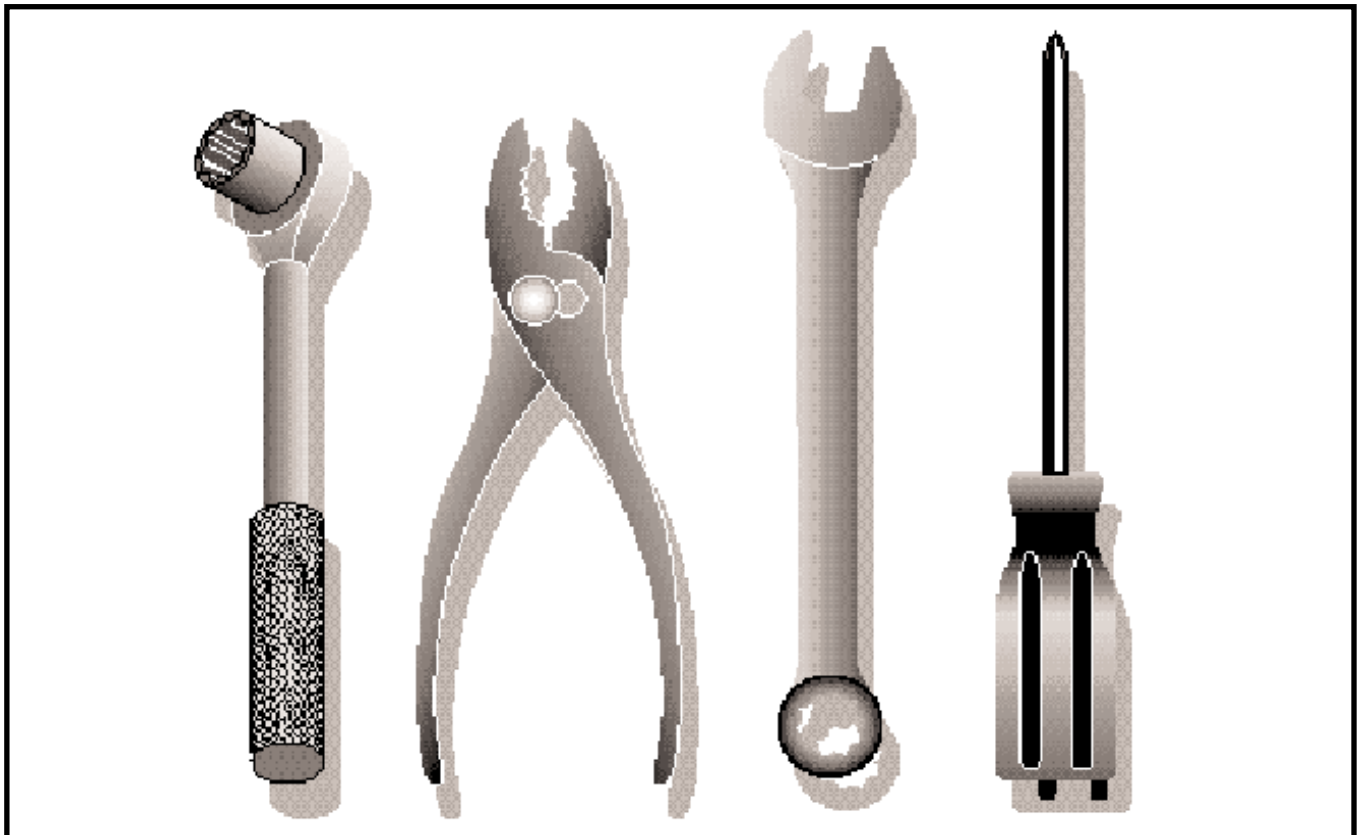

TRACTOR - MODEL NO. 917.279220 (YTH2454T)

SCHEMATIC

02929-194276_Regulated-TEX

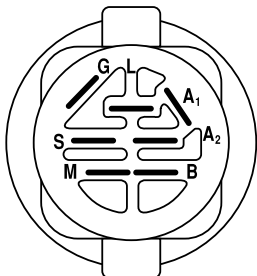
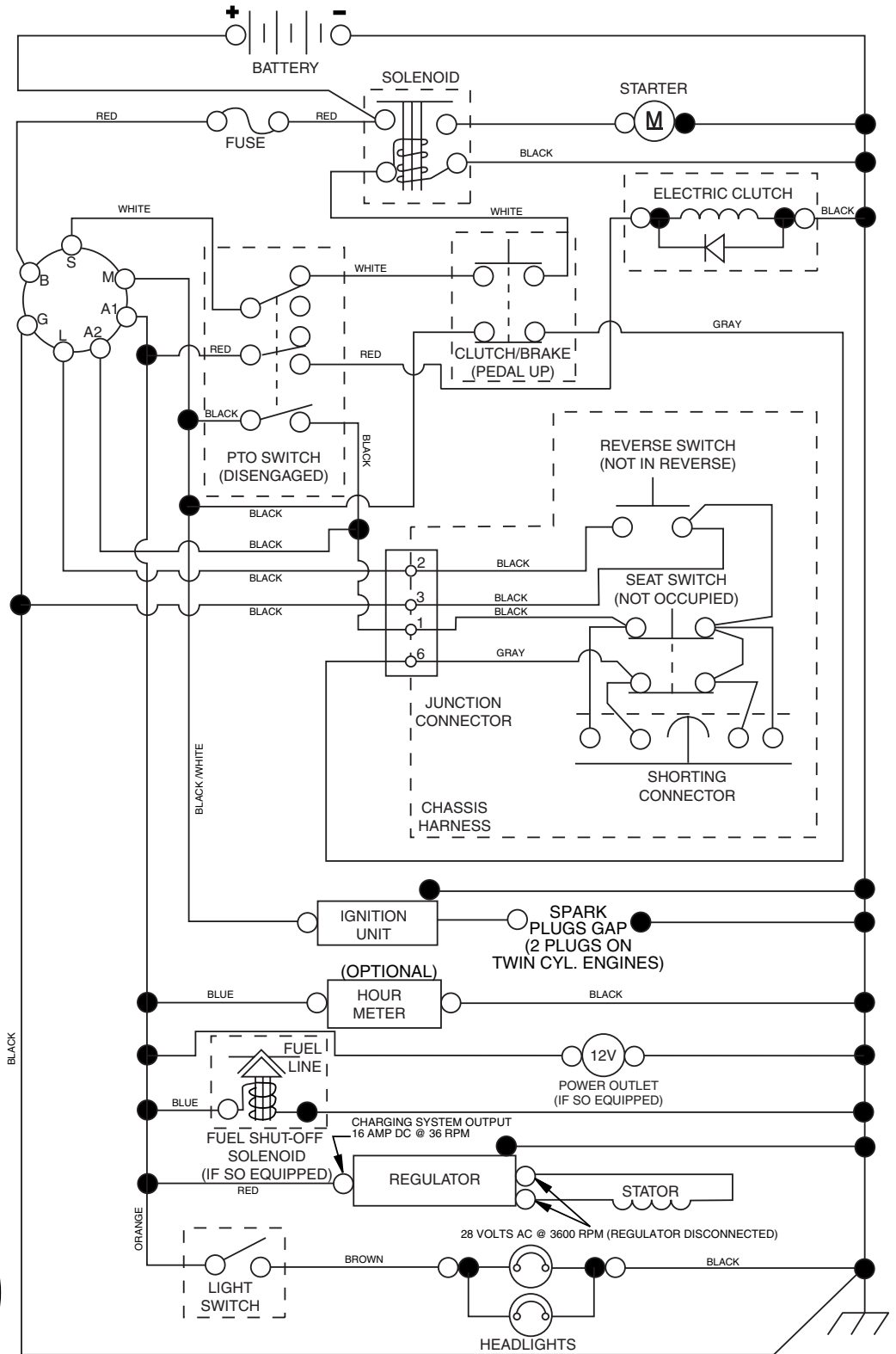

IGNITION SWITCH

POSITION	CIRCUIT	"MAKE"
OFF	M+G+A1	
RUN/OVERRIDE	B+A1	
RUN	B+A1	L+A2
START	B + S + A1	

02929

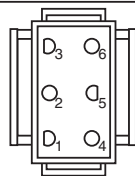

CHASSIS HARNESS CONNECTOR (MATING SIDE)

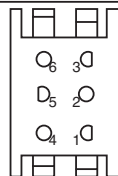

DASH HARNESS CONNECTOR (MATING SIDE)

WIRING INSULATED CLIPS

NOTE: IF WIRING INSULATED CLIPS WERE REMOVED FOR SERVICING OF UNIT, THEY SHOULD BE REPLACED TO PROPERLY SECURE YOUR WIRING.

●
NON-REMOVABLE CONNECTIONS

○
REMOVABLE CONNECTIONS

TRACTOR - MODEL NO. 917.279220 (YTH2454T)

ELECTRICAL

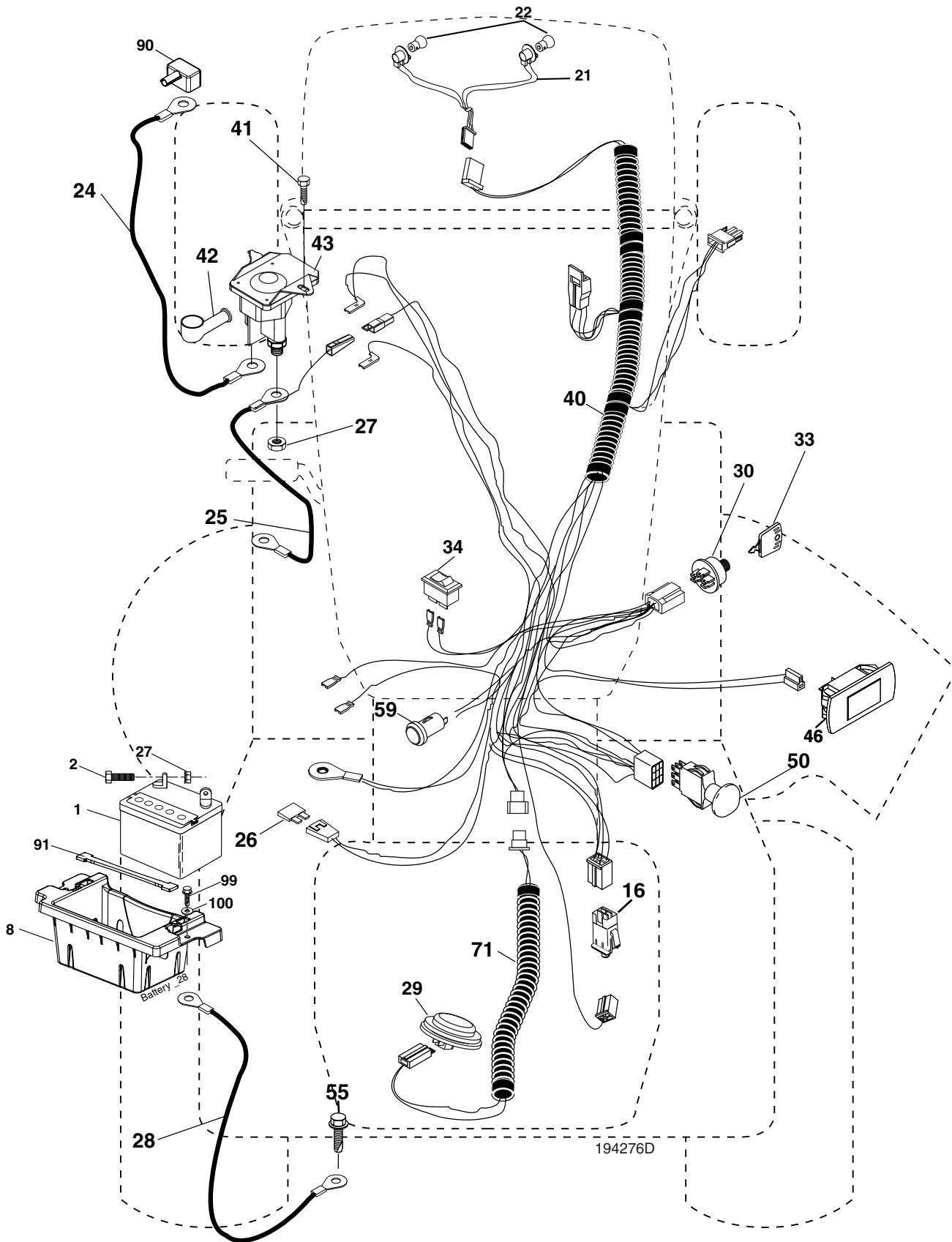

TRACTOR - MODEL NO. 917.279220 (YTH2454T)

ELECTRICAL

KEY NO.	PART NO.	DESCRIPTION
1	532 14 49-27	Battery
2	874 76 04-12	Bolt Hex Hd 1/4-20 unc x 3/4
8	532 18 64-91	Battery Box
16	532 17 61-38	Switch Interlock
21	532 18 37-59	Harness Socket Light
22	532 00 41-52	Bulb, Light # 1156
24	532 40 02-53	Cable Battery
25	532 19 88-93	Cable Starter
26	532 17 51-58	Fuse
27	873 51 04-00	Nut Keps Hex 1/4-20 unc
28	532 14 54-91	Cable Ground 21" Blk 6 Ga.
29	532 40 15-45	Switch Seat
30	532 19 33-50	Switch Ign
33	532 14 04-01	Key Ign Molded Generic
34	532 11 07-12	Switch Light/Reset
40	532 40 11-05	Harness Ign
41	817 72 04-08	Screw Thd Cut 1/4-20 x 1/2
42	532 13 15-63	Cover Terminal Red
43	532 19 25-07	Solenoid
46	532 19 81-38	Gauge Hourmeter
50	532 17 46-51	Switch PTO
55	817 49 05-12	Screw Thdrol 5/16-18 x 3/4
59	532 40 03-03	Outlet 12-Volt
71	532 19 42-76	Harness Ign. Dash
90	532 18 04-49	Cover Terminal Battery
91	532 19 02-70	Strap Battery
99	817 67 04-12	Screw Hexwsh Thdrol 1/4-20 x 3/4
100	819 09 14-16	Washer 9/32 x 7/8 x 16 Ga.

NOTE: All component dimensions given in U.S. inches
1 inch = 25.4 mm

TRACTOR - MODEL NO. 917.279220 (YTH2454T)

CHASSIS

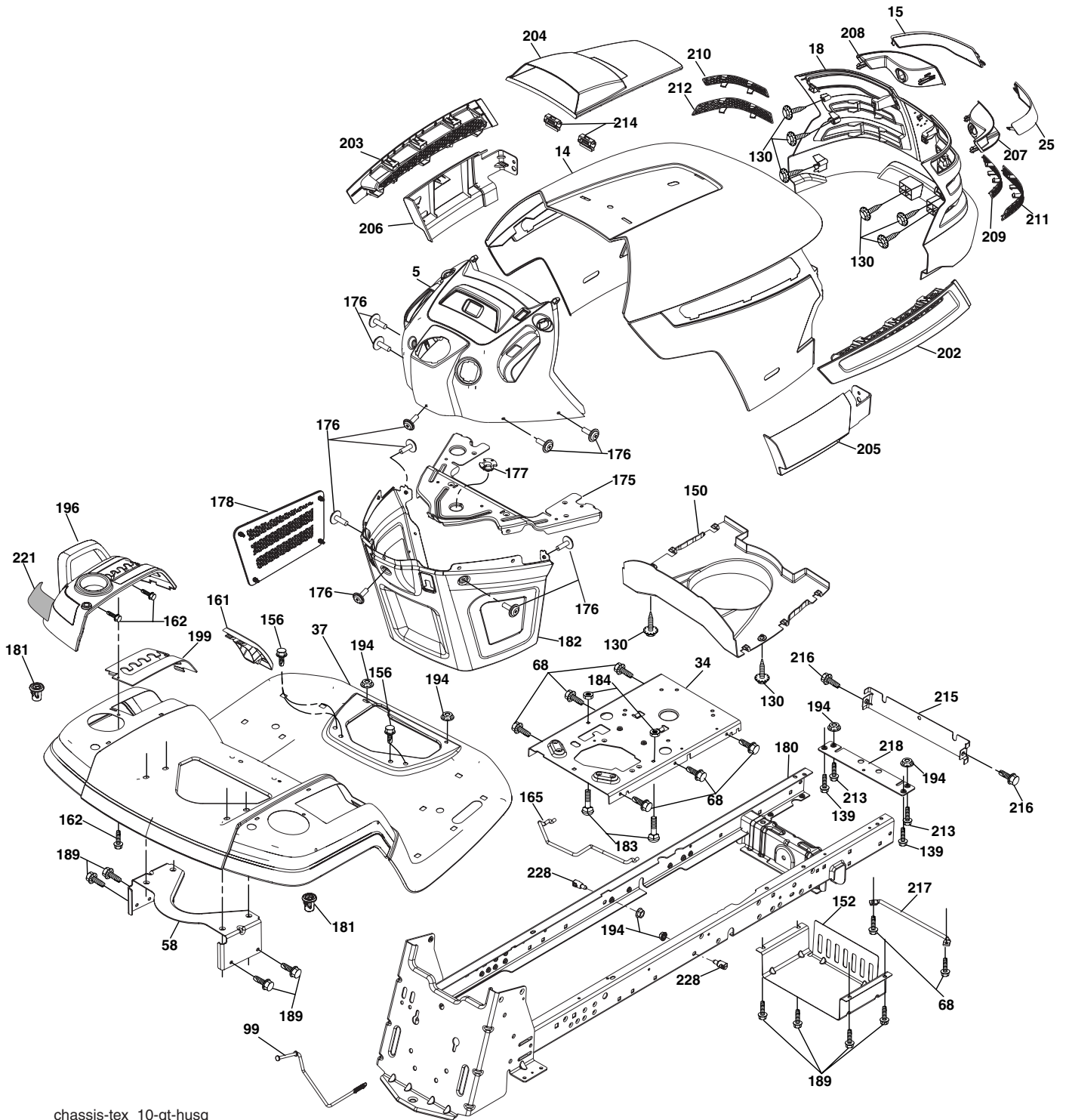

chassis-tex_10-gt-husq

TRACTOR - MODEL NO. 917.279220 (YTH2454T)

CHASSIS

KEY NO.	PART NO.	DESCRIPTION
5	532 40 18-23	Dash
14	532 40 18-24	Hood
15	532 19 89-07	Lens LH
18	532 40 02-97	Grille
25	532 19 89-06	Lens RH
34	532 19 61-25	Plate Engine
37	532 40 18-25	Fender
58	532 19 43-14	Bracket Fender
68	817 49 05-08	Screw 5/16-18 x 1/2
99	532 19 82-53	Rod Bypass Asm.
130	532 19 16-11	Screw 10 x 3/4 Single Lead Hex
139	532 17 18-73	Bolt Shoulder 5/16-18
150	532 19 85-13	Duct Heat Hood
152	532 19 63-90	Shield Browning/Debris
156	817 00 05-12	Screw 5/16-18 x 3/4
161	532 40 18-26	Console Fuel Window
162	532 14 24-32	Screw Hex Wsh Hi-Lo 1/4 x 1/2
165	532 19 68-26	Bracket Support Tank
175	532 19 63-04	Crossmember
176	532 40 07-76	Screw 10-24 x 5/8 Rnd Qdrx
177	532 19 52-27	Bushing Steering
178	532 19 97-82	Cargo Asm. Net
180	532 40 15-59	Chassis
181	532 40 30-25	Bushing Mtg. Fender Crgo.
182	532 19 47-87	Dash Lower
184	532 19 57-80	Spacer

KEY NO.	PART NO.	DESCRIPTION
185	872 11 05-10	Bolt Carr. 5/16-18 x 1-1/4 Gr. 5
189	817 00 05-12	Screw 5/16-18 x 3/4
194	873 90 05-00	Nut Lock Hex Flange 5/16-18
196	532 40 02-99	Console Asm. Deck Lift
199	532 19 82-59	Plate Deck Lift
202	532 40 30-48	Vent Side Hood RH
203	532 40 30-76	Vent Side Hood LH
204	532 19 89-04	Vent Asm Hood Top
205	532 40 17-09	Skirt Hood Side RH
206	532 40 17-11	Skirt Hood Side LH
207	532 19 71-98	Bezel RH
208	532 19 71-99	Bezel LH
209	532 19 91-30	Insert Hex Top RH
210	532 19 91-31	Insert Hex Top LH
211	532 19 91-32	Insert Hex Bottom RH
212	532 19 91-33	Insert Hex Bottom LH
213	874 76 05-12	Bolt Hex Hd 5/16-18 unc x 3/4
214	532 19 91-45	Clip Retainer
215	532 19 80-43	Cover Chassis Front
216	817 67 05-08	Screw 5/16-18 x 1/2
217	532 15 65-24	Rod Pivot
218	532 19 63-95	Hood Stop
221	532 19 89-09	Reflector LH
228	532 19 51-61	Stud Fastner

NOTE: All component dimensions given in U.S. inches
1 inch = 25.4 mm

TRACTOR - MODEL NO. 917.279220 (YTH2454T)

DRIVE

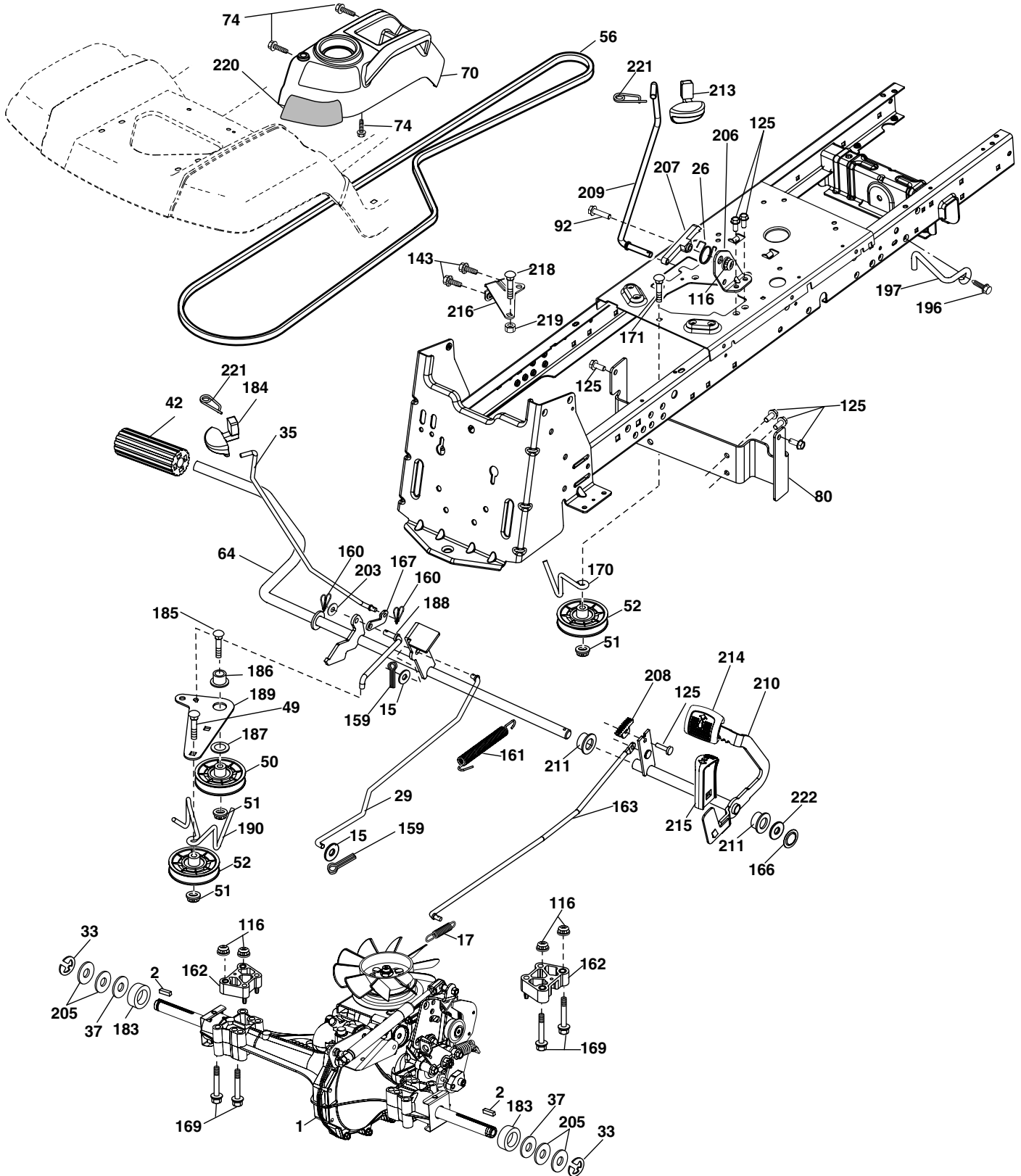

drive-tex_10-husq-hydro-0510

TRACTOR - MODEL NO. 917.279220 (YTH2454T)

DRIVE

KEY NO.	PART NO.	DESCRIPTION	KEY NO.	PART NO.	DESCRIPTION
1	-----	Transaxle, Hydro 354-0510 (See Breakdown)	170	532 19 43-22	Keeper Belt Centerspan
2	532 12 35-83	Key 1/4 x 2.5	171	872 11 06-16	Bolt
15	819 13 13-16	Washer 13/32 x 13/16 x 16 Ga.	183	532 13 70-57	Spacer Split
17	532 19 72-96	Spring, Brake	184	532 40 31-18	Handle Parking Brake
26	532 19 96-79	Spring Return Cruise	185	872 11 06-20	Bolt Rdhd Sqnk 3/8-16 x 2-1/2
29	532 19 94-67	Rod, Brake	186	532 19 43-21	Spacer Retainer
33	812 00 00-01	Ring E	187	819 13 32-10	Washer
35	532 19 95-91	Rod, Brake, Park	188	532 19 43-23	Link Clutch Ground Drive
37	532 12 17-49	Washer	189	532 19 43-17	Bellcrank Ground Drive
42	532 12 48-72	Cover, Foot Pedal	190	532 19 43-18	Keeper Bellcrank Ground Drive
49	872 11 06-14	Bolt	196	817 00 06-16	Screw 3/8-16 x 1
50	532 19 43-27	Pulley Idler Flat	197	532 19 97-69	Bracket Clutch Anti-Rotation
51	873 90 06-00	Lock Nut 3/8-16	203	819 11 11-16	Washer 11/32 x 11/16 x 16 Ga.
52	532 19 43-26	Idler V-Groove 910" Offset	205	532 12 17-48	Washer
56	532 14 02-18	V-Belt, Drive	206	532 19 78-67	Bracket Mount Latch Cruise
64	532 19 78-65	Shaft Asm. Pedal Brake Control	207	532 19 78-68	Latch Control Cruise
70	532 40 05-30	Control Asm.	208	532 19 78-69	Gear Sector Control Cruise
74	532 14 24-32	Screw 1/4 x 1/2	209	532 19 95-92	Rod Control Cruise
80	532 40 05-07	Bracket Strap Torque	210	532 19 78-60	Rocker Asm. Pedal Control
92	874 76 05-20	Bolt Fin Hex 5/16-18 unc x 1.25	211	532 12 01-83	Bearing Nylon
116	873 90 05-00	Nut Lock Hex Flange 5/16-18	213	532 40 31-19	Knob Control Cruise
125	817 00 05-12	Screw 5/16-18 x 3/4	214	532 40 17-22	Pedal Forward
143	817 49 05-08	Screw Thdrol 5/16-18 x 1/2	215	532 40 17-23	Pedal Reverse
148	817 00 06-12	Screw 3/8-16 x 3/4	216	532 19 61-31	Bracket Pulley Idler
159	876 02 04-12	Pin Cotter 1/8 x 3/4	218	874 78 05-20	Bolt Fin Hex 5/16-18 unc x 1-1/4
160	532 16 94-84	Retainer Clip	219	532 19 57-80	Spacer Fender
161	532 19 54-03	Spring, Return, Clutch	220	532 19 89-08	Reflector RH
162	532 19 57-85	Spacer Transaxle	221	532 40 31-87	Retainer Spring Clip Handle
163	532 19 90-00	Rod Pedal Control	222	819 21 20-12	Washer Flat
166	532 19 72-90	Nut Push .625			
167	532 19 62-11	Latch Brake Parking			
169	874 49 05-60	Bolt Hex Flghd 5/16-18 x 3.75			

NOTE: All component dimensions given in U.S. inches
1 inch = 25.4 mm

TRACTOR - MODEL NO. 917.279220 (YTH2454T)

STEERING ASSEMBLY

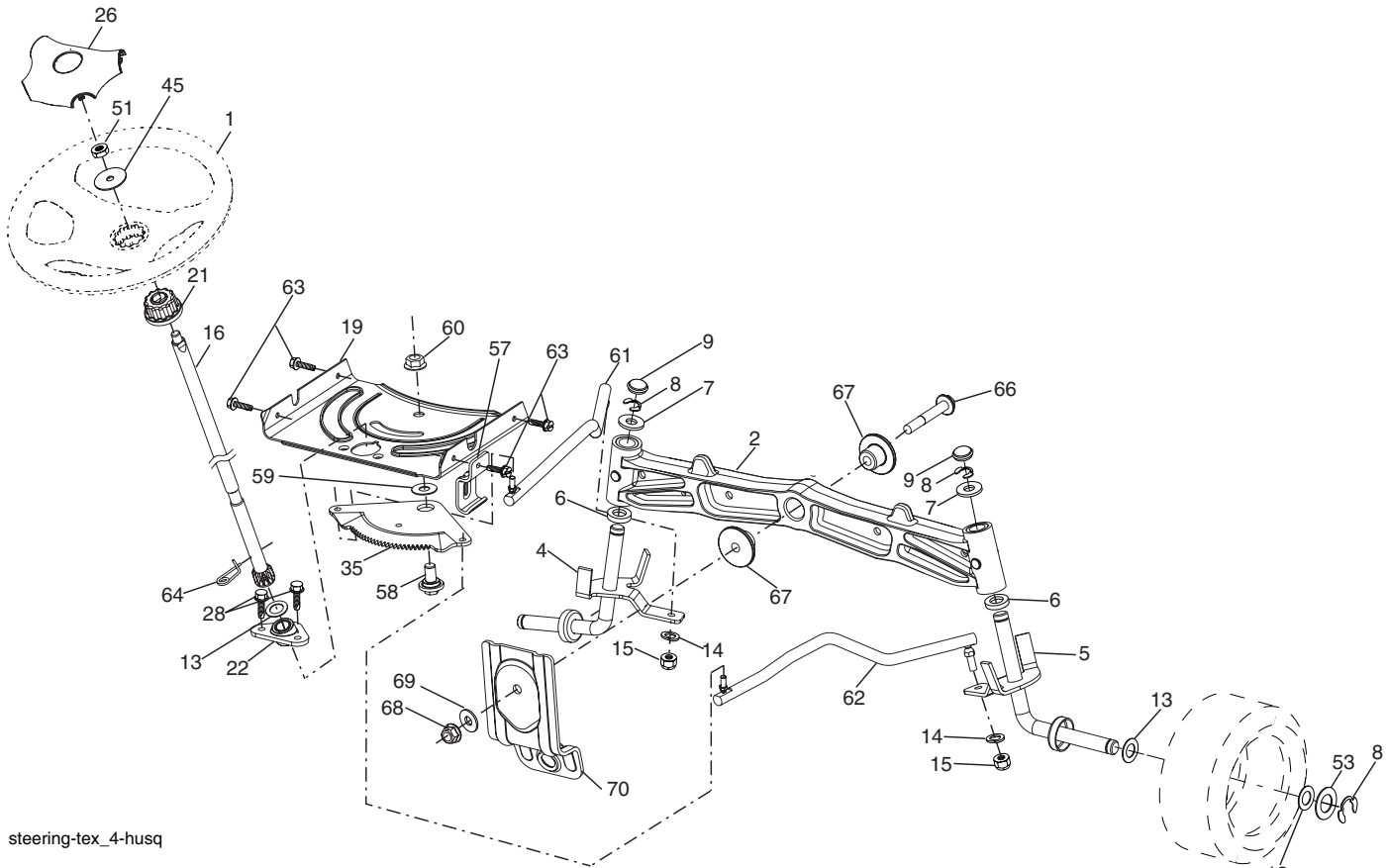

steering-tex_4-husq

KEY NO.	PART NO.	DESCRIPTION
1	532 19 39-43	Wheel, Steering
2	532 19 59-68	Axle Asm., Front
4	532 19 47-43	Spindle Asm., LH
5	532 19 47-44	Spindle Asm., RH
6	532 12 49-31	Bearing, Race Thrust Harden
7	532 12 17-48	Washer 25/32 x 1-5/8 x 16 Ga.
8	812 00 00-29	Ring, Klip #T5304-75
9	532 12 12-32	Cap, Spindle
13	532 12 17-49	Washer 25/32 x 1-1/4 x 16 Ga.
14	810 04 06-00	Washer, Lock Hvy Hlcl Spr 3/8
15	873 54 06-00	Nut, Crown Lock 3/8-24 unf
16	532 19 47-46	Shaft Steering
19	532 19 47-29	Plate Steering
21	532 18 67-37	Adapter, Wheel Steering
22	532 19 48-45	Bushing, Strg. Blk
26	532 19 36-52	Insert, Wheel Steering
28	817 00 06-12	Screw 3/8-16 x 3/4
35	532 19 47-32	Gear, Sector Plate
45	819 18 38-12	Washer 9/16 x 2-3/8 x 12 Ga.

KEY NO.	PART NO.	DESCRIPTION
51	873 94 08-00	Nut Hex Jam Toplock 1/2-20 unf
53	532 18 89-67	Washer Hardened .793 x 1.637 x .060
57	532 19 72-46	Bracket Upstop
58	532 19 47-47	Bolt Shoulder Sector Pivot CFM
59	532 19 47-48	Washer Thrust Sector Steering
60	873 97 10-00	Nut Flange Lock 5/8-11
61	532 19 47-40	Draglink LH
62	532 19 47-41	Draglink, RH
63	817 00 05-12	Screw 5/16-18 x 3/4
64	532 19 98-49	Retainer Clip Spring Steering
66	871 02 07-48	Bolt Hex Fghd 7/16-14 x 3 Serr
67	532 19 47-37	Bushing PM Front Axle
68	873 90 07-00	Nut Lock Flange 7/16-14 Gr. 5
69	532 19 91-62	Washer 1.5 x .505 x .118
70	532 19 61-97	Bracket Deck Susp. Front

NOTE: All component dimensions given in U.S. inches
1 inch = 25.4 mm

TRACTOR - MODEL NO. 917.279220 (YTH2454T)

MOWER LIFT

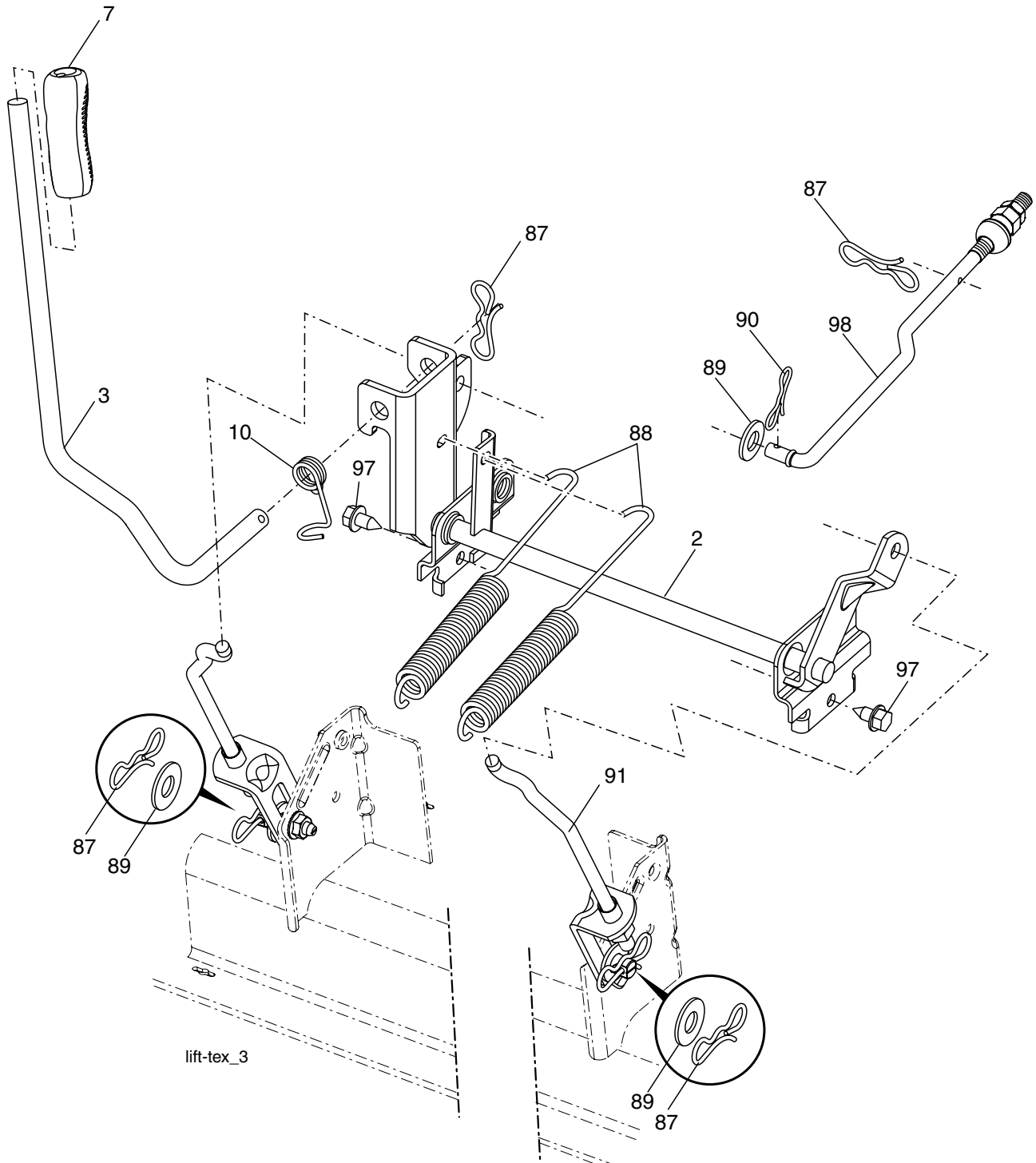

KEY NO.	PART NO.	DESCRIPTION
2	532 19 52-23	Shaft Asm., Lift
3	532 19 52-30	Lever Asm., Lift Rh
7	532 19 64-92	Grip, Lever
10	532 19 63-14	Spring Torsion
87	532 19 42-09	Pin Cotter 7/16 Bow Tie Lock
88	532 19 53-04	Spring Lift Assist
89	819 19 19-12	Washer Clear Zinc

KEY NO.	PART NO.	DESCRIPTION
90	532 19 42-08	Pin Cotter 5/16 Bow Tie Lock
91	532 19 51-81	Link Lift Susp Mower Rear
97	817 06 06-12	Screw 3/8-16 x .75 Smgml Tap/R.Z
98	532 19 52-64	Link Lift Susp. Front Mower

NOTE: All component dimensions given in U.S. inches
1 inch = 25.4 mm

TRACTOR - MODEL NO. 917.279220 (YTH2454T)

SEAT ASSEMBLY

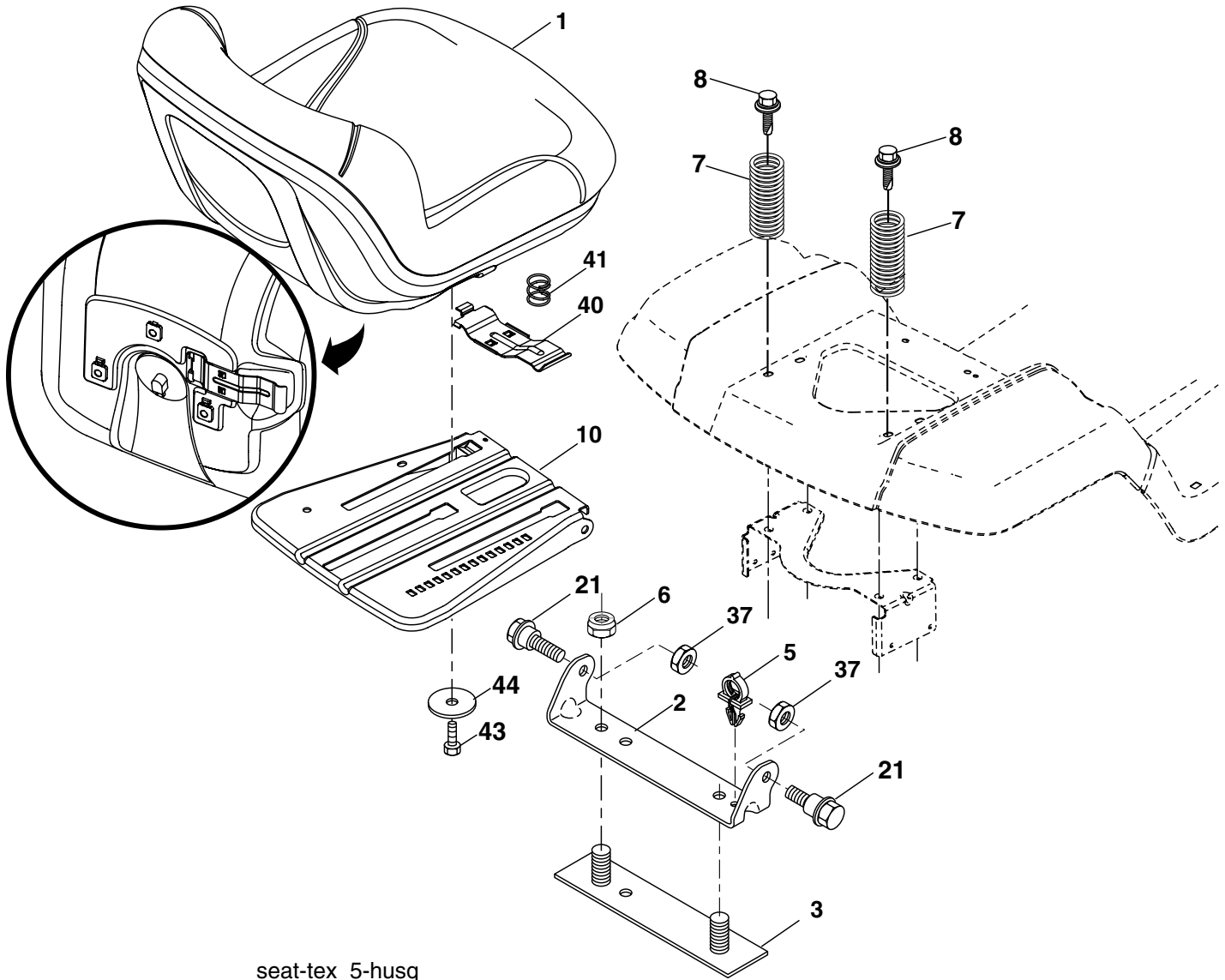

seat-tex_5-husq

KEY NO.	PART NO.	DESCRIPTION
1	532 19 75-26	Seat
2	532 18 01-66	Bracket Pivot Fender
3	532 14 06-75	Strap, Asm Fender
5	532 14 50-06	Clip, Push In, Hinged
6	873 80 06-00	Nut, Lock W/Ins. 3/8-16 unc
7	532 12 41-81	Spring, Seat Cprsn
8	532 17 18-77	Bolt 5/16-18 uncx 3/4 w/Sems
10	532 19 69-77	Pan, Seat
21	532 17 18-52	Bolt, Shoulder 5/16-18

KEY NO.	PART NO.	DESCRIPTION
37	873 80 05-00	Nut, Lock 5/16-18 unc
40	532 19 76-61	Handle Slide Seat
41	532 19 82-00	Spring Latch Seat
43	874 76 06-12	Bolt 3/8-16 x 3/4
44	819 13 38-12	Washer 13/32 x 2-3/8 x 12 Ga.

NOTE: All component dimensions given in U.S. inches
1 inch = 25.4 mm

TRACTOR - MODEL NO. 917.279220 (YTH2454T)

DECALS

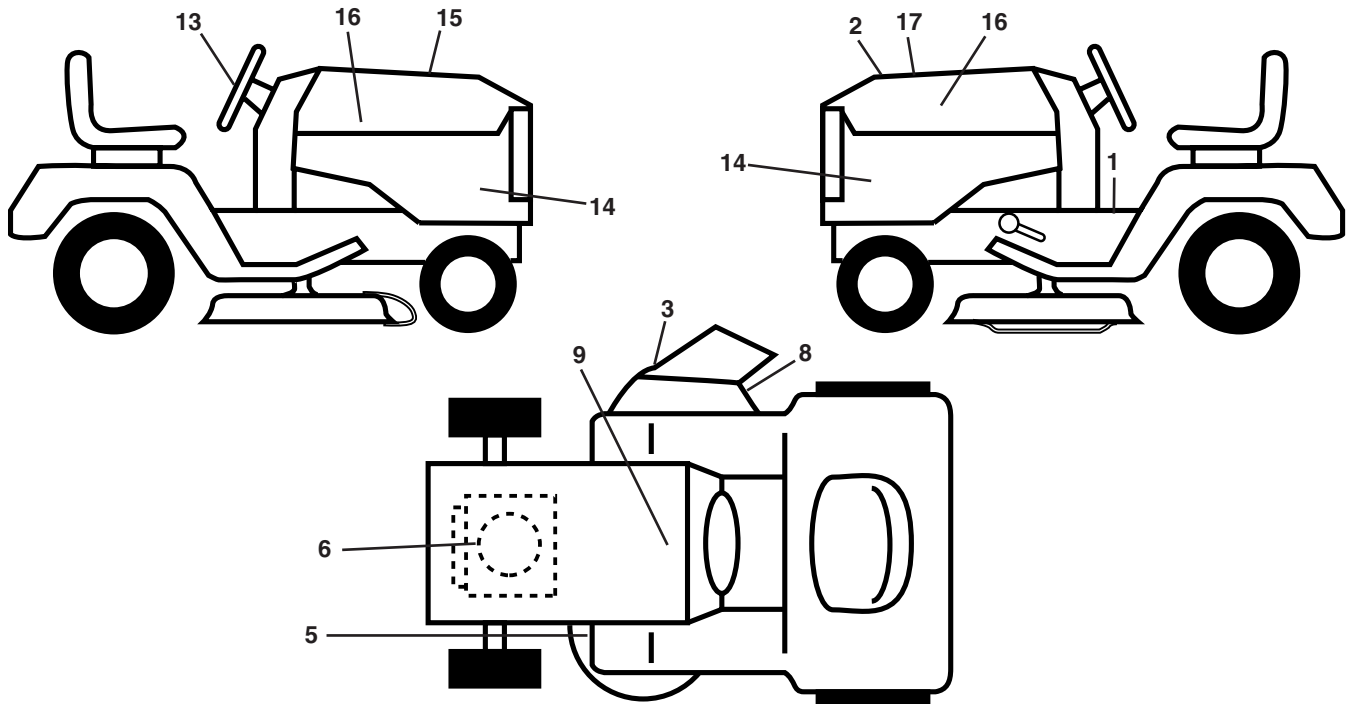

KEY NO.	PART NO.	DESCRIPTION
1	532 40 21-04	Decal, Operator's
2	532 40 21-28	Decal, Hood Insert
3	532 17 05-63	Decal, Warning
5	532 17 85-02	Decal, Caution
6	532 18 96-84	Decal, Eng. HP
8	532 19 87-85	Decal, Mower Sch.
9	532 14 50-05	Decal, Battery Dnge/Poi
13	532 18 89-25	Decal, Steering Whl

KEY NO.	PART NO.	DESCRIPTION
14	532 40 35-28	Decal, Panel Side
15	532 18 09-41	Decal, Cust. Resp.
16	532 40 28-32	Decal, Hood Logo
17	532 40 35-72	Decal, Replacement
--	532 16 69-60	Decal, Bypass
--	532 40 17-71	Pad, Footrest, LH
--	532 40 37-73	Pad, Footrest, RH
--	532 40 34-61	Manual, Owner's (Eng)
--	532 40 34-62	Manual, Owner's (Fr)

WHEELS AND TIRES

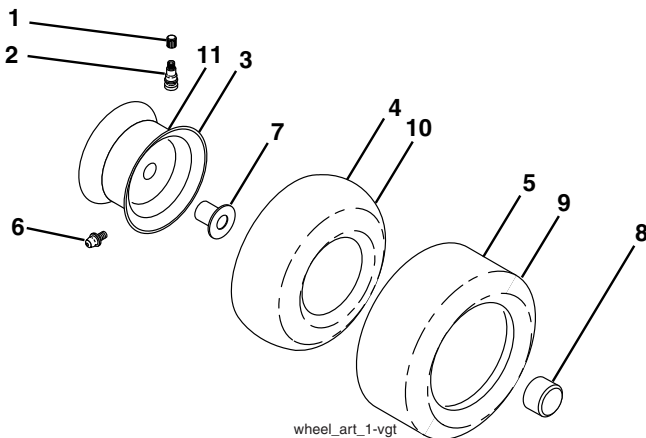

KEY NO.	PART NO.	DESCRIPTION
1	532 05 91-92	Cap, Valve, Tire
2	532 06 51-39	Stem, Valve
3	532 13 83-36	Rim Assembly, Front
4	532 00 81-34	Tube, Front (Service Item Only)
5	532 10 62-22	Tire, Front
6	532 00 02-78	Fitting, Grease (Front Wheel Only)
7	532 00 90-40	Bearing, Flange (Front Wheel Only)
8	532 17 50-39	Cap, Axle (Front Wheel Only)
9	532 12 20-82	Tire, Rear
10	532 00 71-54	Tube, Rear (Service Item Only)
11	532 13 83-37	Rim Assembly, Rear
--	532 14 43-34	Sealant, Tire (10 oz. Tube)

NOTE: All component dimensions given in U.S. inches
1 inch = 25.4 mm

TRACTOR - MODEL NO. 917.279220 (YTH2454T)

MOWER DECK

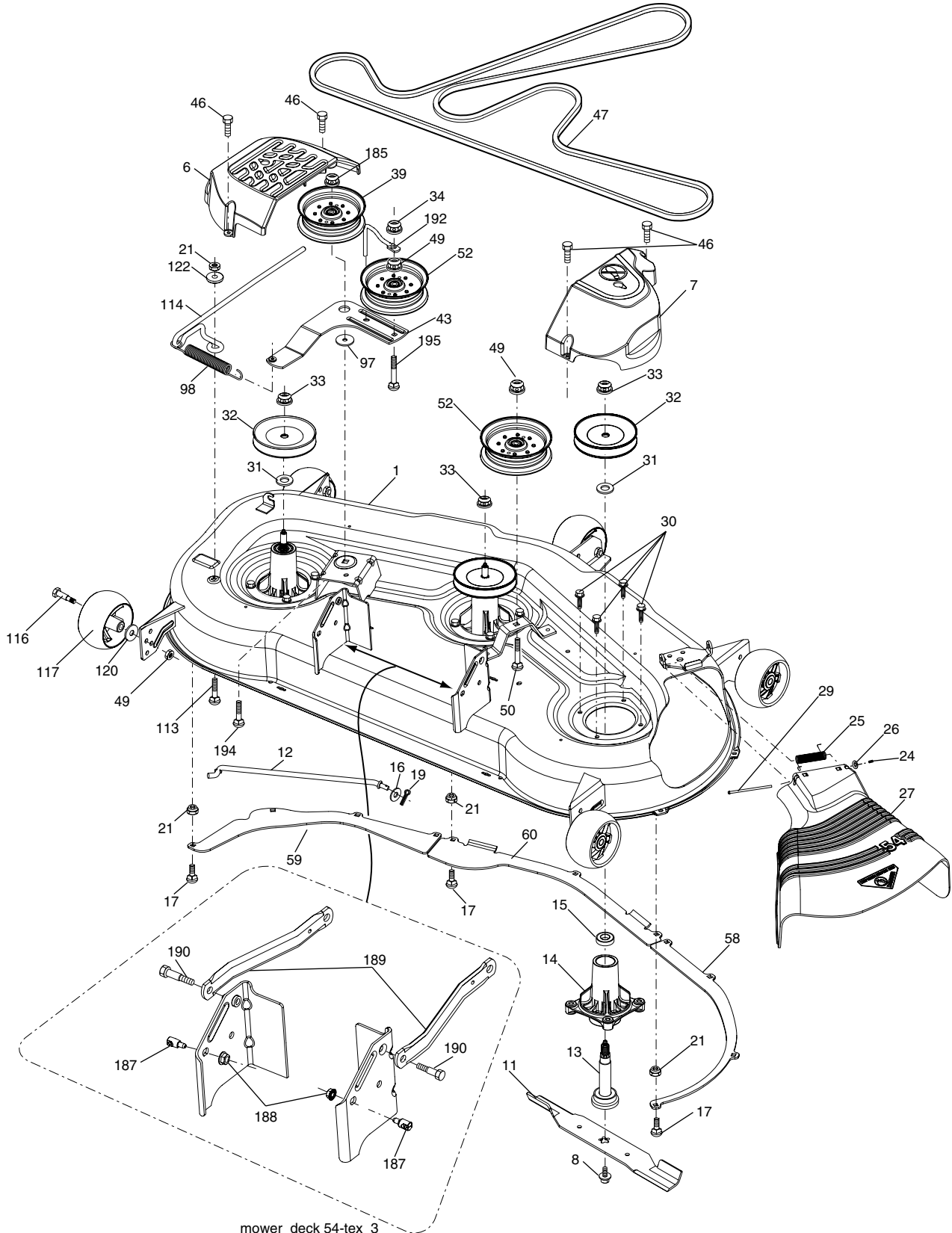

TRACTOR - MODEL NO. 917.279220 (YTH2454T)

MOWER DECK

KEY NO.	PART NO.	DESCRIPTION	KEY NO.	PART NO.	DESCRIPTION
1	532 40 31-25	Deck Weldment Mower	50	872 11 06-16	Bolt Rdhd Sqnk 3/8-16 unc x 2
6	532 19 60-66	Cover Mandrel LH	52	532 19 61-06	Pulley Idler
7	532 19 71-81	Cover Mandrel RH	58	532 18 73-42	Baffle Right
8	532 17 43-65	Bolt 7/16 Asm. Blade	59	532 18 73-44	Baffle Left
11	532 18 72-56	Blade Bagging	60	532 18 76-07	Baffle Center
--	532 18 72-55	Blade Mulching	97	532 17 85-15	Washer Hardened
12	532 40 03-37	Rod Anti-Sway	98	532 19 61-05	Spring Drive
13	532 18 72-91	Shaft Asm. w/Lower Bearing	113	872 11 05-08	Bolt Rdhd Sqnk 5/16-18 x 3/4
14	532 18 72-81	Housing, Mandrel	114	532 18 75-56	Rod Tension Relief
15	532 11 04-85	Bearing, Ball, Mandrel	116	532 19 34-06	Bolt, Shoulder
16	819 13 13-12	Washer 13/32 x 13/16 x 12 Ga.	117	532 17 48-73	Gauge Wheel
17	872 14 05-05	Bolt Rdhd Sqnk 5/16-18 x 5/8	120	819 13 20-12	Washer 13/32 x 1-1/4 x 12 Ga.
19	532 19 42-08	Pin Cotter 5/16 Bow Tie Lock	122	532 18 75-57	Bushing Tension Relief
21	873 68 05-00	Nut, Crownlock 5/16-18 unc	185	873 90 07-00	Nut Lock Flange 7/16-14 Gr. 5
24	532 10 53-04	Cap Sleeve	187	532 19 51-61	Stud Fastener w/"D" Anti-Rotation
25	532 17 81-02	Spring, Torsion	188	873 90 05-00	Nut Lock Hex Flange
26	532 11 04-52	Nut, Push	189	532 19 51-85	Arm Susp. Mower Rear
27	532 18 89-38	Deflector Shield	190	532 19 65-39	Bolt Shoulder
29	532 13 14-91	Rod, Hinge	192	532 19 84-68	Keeper Belt Idler
30	532 17 39-84	Screw, Thdroll Washer Head	194	872 14 07-16	Bolt Carr Sqnk 7/16-24 x 2
31	532 18 76-90	Washer, Spacer Mower Vented	195	872 14 06-20	Bolt Rdhd Sqnk 3/8-16 x 2-1/2 Gr. 5
32	532 17 34-35	Pulley, Mandrel	--	532 18 72-92	Mandrel Asm. Service (Includes Key Nos. 13-15 and 33)
33	532 40 02-34	Nut, Fig. Top Lock	--	532 19 93-00	Replacement Mower, Complete
34	873 68 06-00	Nut Crownlock 3/8-16 unc			
39	532 19 61-04	Pulley, Idler, Stationary LH			
43	532 19 60-65	Arm, Idler			
46	532 13 77-29	Screw, Thdroll. 1/4-20 x 5/8			
47	532 19 61-03	Belt Deck Drive			
49	873 90 06-00	Nut, Lock Flg. 3/8-16 unc			

NOTE: All component dimensions given in U.S. inches
1 inch = 25.4 mm

TRACTOR - MODEL NO. 917.279220 (YTH2454T)

ENGINE

KEY NO.	PART NO.	DESCRIPTION
1	-----	Engine Briggs Model No. 445677-0413-E1 (See Breakdown)
2	532 14 97-23	Muffler
9	532 19 43-19	Keeper Belt Engine
11	532 17 93-34	Clutch Electric
12	532 40 29-80	Pulley Engine
15	532 19 34-99	Tank Fuel 4.0
18	532 19 42-67	Cap Asm
20	532 17 83-85	Control Throttle
21	532 19 16-11	Screw 10 x 3/4 Single Lead Hex
22	532 19 15-96	Control Choke
28	532 40 11-35	Fuel Line
29	532 13 71-80	Spark Arrester Kit
31	532 14 50-06	Clip Push-In
37	532 12 34-87	Clamp Hose
41	532 12 61-97	Washer 1-1/2 OD x 15/32 ID x .250
42	810 04 07-00	Washer Lock 7/16
43	532 15 02-80	Bolt Hex 7/16-20 x 4-1/4 Gr. 5
45	873 51 04-00	Nut Keps Hex 1/4-20 unc
62	532 14 66-29	Shield Heat Muffler
69	532 16 53-91	Gasket
70	532 15 99-55	Tube Exhaust LH
71	532 16 05-89	Tube Exhaust RH
79	532 18 39-06	Screw Socket Head 5/16-18 x 1
81	532 14 84-56	Tube Drain Oil Easy
82	532 18 16-54	Plug Drain Oil
84	817 06 06-24	Screw 3/8-16 x 1/2
87	532 19 82-39	Bolt 5/16-18 unc x 1 w/Sems
90	817 00 06-16	Screw 3/8-16 x 1
91	532 18 74-95	Bushing

NOTE: All component dimensions given in U.S. inches
1 inch = 25.4 mm

TRACTOR - MODEL NO. 917.279220 (YTH2454T)

HYDRO TRANSAXLE - - MODEL NUMBER 354-0510

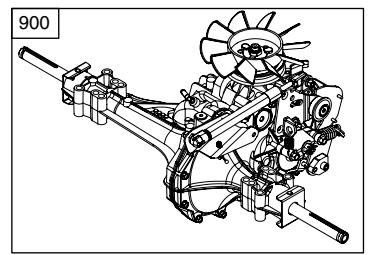
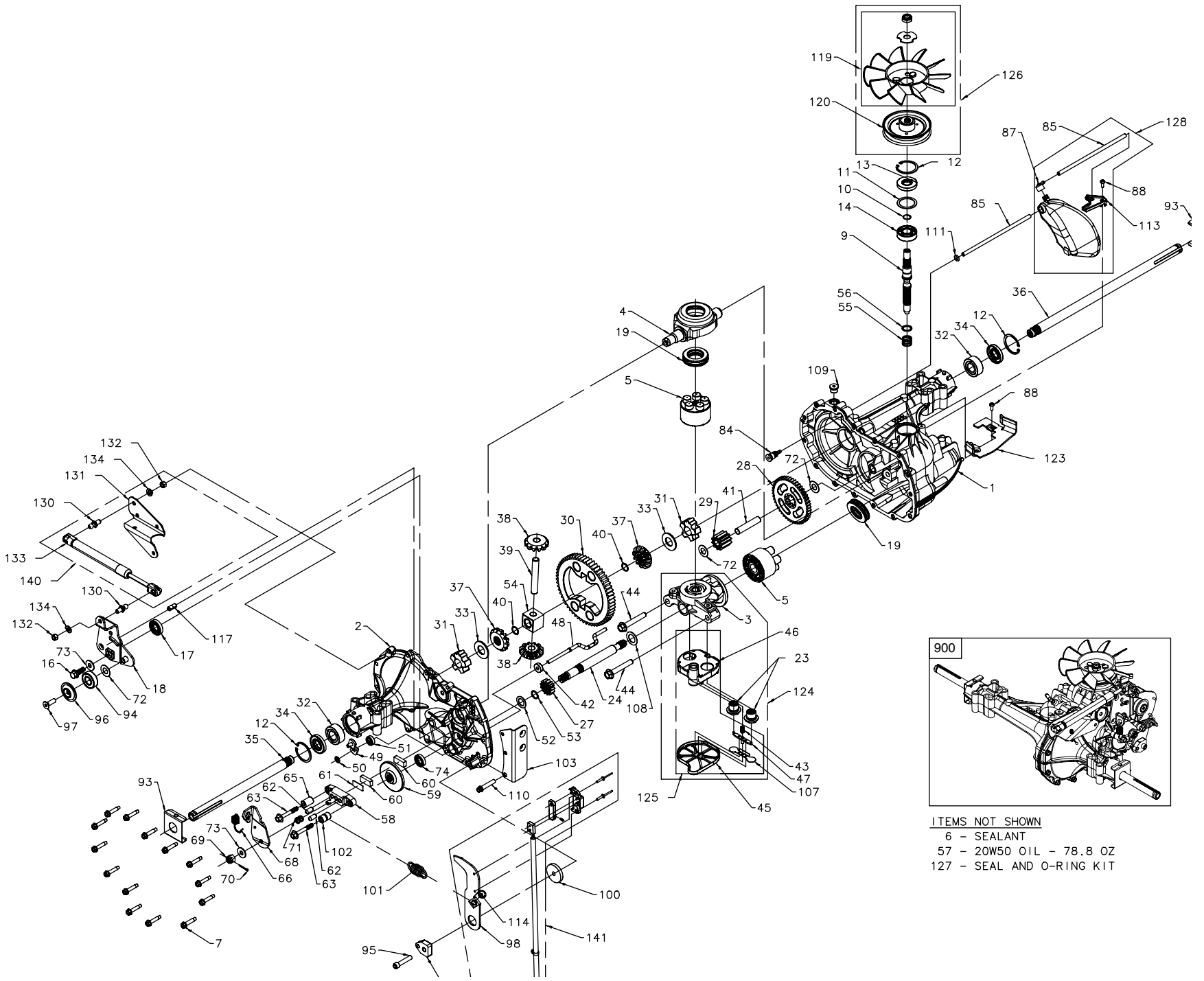

- ITEMS NOT SHOWN
 6 - SEALANT
 57 - 20W50 OIL - 78.8 OZ
 127 - SEAL AND O-RING KIT

TRACTOR - MODEL NO. 917.279220 (YTH2454T)

HYDRO TRANSAXLE - - MODEL NUMBER 354-0510

KEY NO.	PART NO.	DESCRIPTION	KEY NO.	PART NO.	DESCRIPTION
1	170351	Kit, main housing Main housing, machined	72	170418	Washer (310-0750)
		Bushing .865 X.985 X.790	73	142884	Washer, flat
2	170352	Kit, side housing	74	170419	Seal, oil
		Side housing, machined	84	170425	Fitting, 5/16 x sae 5/32 tube
		Bushing .865 X.985 X.790	85	170426	Hose, expansion tank
		Bushing .624 X.719	87	401264	Cap, barbed vent
		X.562	88	178334	Bolt, self tapping (BDR)
3	170353	Kit, center section Center section, machined	93	170431	Spring clip, housing
		Bushing .707 X .788 X .591	94	178783	Bearing, ball
4	170354	Swashplate, trunnion machined	95	178784	Screw, 5/16-24x 1 1/2 socket head cap (310-3000)
5	169898	Kit, cylinder block (1000)	96	178786	Spacer, locating
		Block - cylinder Piston, Spring, compression	97	178787	Screw (310-3000)
		Washer thrust	98	404027	Arm, return
6	178322	Sealant tube	99	178792	Puck, adjusting
7	170356	Hexflange screw 1/4-20 x 1.25	100	178793	Washer, .325 Odxl.6 ldx.15 TK
9	170358	Shaft, input	101	178794	Spring, extension
10	170359	Retaining ring	102	178795	Spacer, .56 Odx.26 ID x.87
11	170360	Spacer	103	404028	Bracket, torque
12	169870	Retaining ring	107	170432	Deflector
13	170361	Seal, lip .67 X 1.58 X .276	108	170433	Washer, motor shaft.71 ID x 1.150D x.03 Thick
14	173158	Bearing, ball 6203 (BDR)	109	170434	Plug, straight thread 9/16-18
16	170362	Hex flange head screw 1/4-20 x 1.25	110	161159	Screw, torx head 5/16-18 (310-3000)
17	170363	Seal, lip 18 x 32 x 7	111	170435	O-ring .7 X .301 ID
18	178781	Arm, control	113	170437	Bracket, support expansion tank
19	173159	Bearing, thrust (10cc)	114	178797	Spring guide
23	170420	Check plug assembly, .027 Washer	117	178799	Pin, spring 5/16 x.75
24	170366	Shaft motor	119		191031 Kit, fan - washer - nut, Fan, 7 in
27	170367	Gear, pinion, 13T			Hex lock nut 1/2-20 (nylon insert)
28	170368	Gear 1 OT / 48T	120	170440	Washer, or slotted, .53 X 1.63 X.06
29	170369	Gear, 1 OT jackshaft	123	401265	Pulley
30	170370	60T bullgear	124	191033	Belt keeper
31	170371	Sleeve bearing .75 X 1.75 X.625			Center section filter bypass assembly Center section
32	170389	Sleeve bearing (outboard) .75 X 1.575 X.625			Base filter w/ poppet check plug assembly,
33	142991	Washer			.027 Washer Spring, bypass actuator, bypass
34	170390	Lip seal, axle shaft			deflector bottom, filter bushing, .707 X.788
35	170391	Shaft, axle (keyed, R.H.)			X.591
36	170392	Shaft, axle (keyed, L.H.)	125	170445	Kit, filter Bottom, filter spring, bypass actuator,
37	401260	Miter gear (splined)			bypass deflector
38	401261	Miter gear	126	170446	Base, filter w/ poppet
39	150809	Differential shaft (310-0750)			Kit, fan/pulley, Hex jam 1/20-20 (nylon insert)
40	170393	Retaining ring			washer, OD slotted, .53 X 1.63 X.06 Fan, 7 in,
41	170394	Pin, jackshaft	127	170447	Pulley
42	170395	Magnet, ring			Kit, seal
43	170396	Spring, bypass			Lip seal .67 X 1.58 X.276 Lip seal 18 x 32 x 7
44	150797	Bolt 3/8-24 x 2-1/2			Lip seal .706 X 1.584 X.25 Lip seal .741 X.250
45	170397	Filter			X.250
46	170398	Base, filter	128	401266	TC oil seal .625 X1.0X .25 O-ring .07 X .301 ID
47	170399	Actuator, bypass			Kit, expansion tank, Tank, expansion assembly
48	170400	Rod, bypass actuator			cap, barbed vent., Bolt, self tapping 10-32 x 1/2
49	196599	Arm, bypass			bracket, support expansion tank hose, expansion tank
50	170402	Retaining ring.25 External	130	178802	Stud, threaded ball
51	170403	Seal, lip .741 X .25 X .25	131	178803	Bracket, cruise/damper
52	170404	Washer, flat 0.050" (210-1000)	132	178804	Nut 5/16-18
53	170405	Retaining ring	133	184227	Damper
54	170406	Bearing, center block	134	178808	Washer, 5/16 lock
55	142977	Spring, helical compression	140	191030	Kit, damper, Stud, threaded ball bracket,
56	142978	Washer, block thrust			cruise/damper hex nut 5/16-18 NC damper,
57	20Vv-50	Oil			Washer, helical spring lock 5/16, regular
58	142929	Kit, brake yoke	141	404030	Kit, RCS, Arm, return spring guide switch,
59	170408	Rotor, brake			RCS activator, RC Sswitch spring, RCS switch
60	142883	Brake puck			retainer, RCS switch rivet 5/32
61	142882	Brake puck plate			Transaxle
62	170409	Pin, brake actuating			
63	170410	Hfhcs 1/4-20 x 2 w/patch, special flange			
65	170411	Spacer, brake torsion spring			
66	189386	Spring, brake arm bias	900	400505	
68	404026	Arm-brake, RH			
69	170415	Nut, castle 5/16-24			
70	170416	Pin, cotter 3/32x3/4			
71	170417	Brake spring			

Note: All Component Dimensions Given In U.S. Inches 1 Inch = 25.4 mm

REPAIR PARTS

TRACTOR - - MODEL NUMBER 917.279220

BRIGGS ENGINE - MODEL NUMBER 445677, TYPE NUMBER 0413-E1

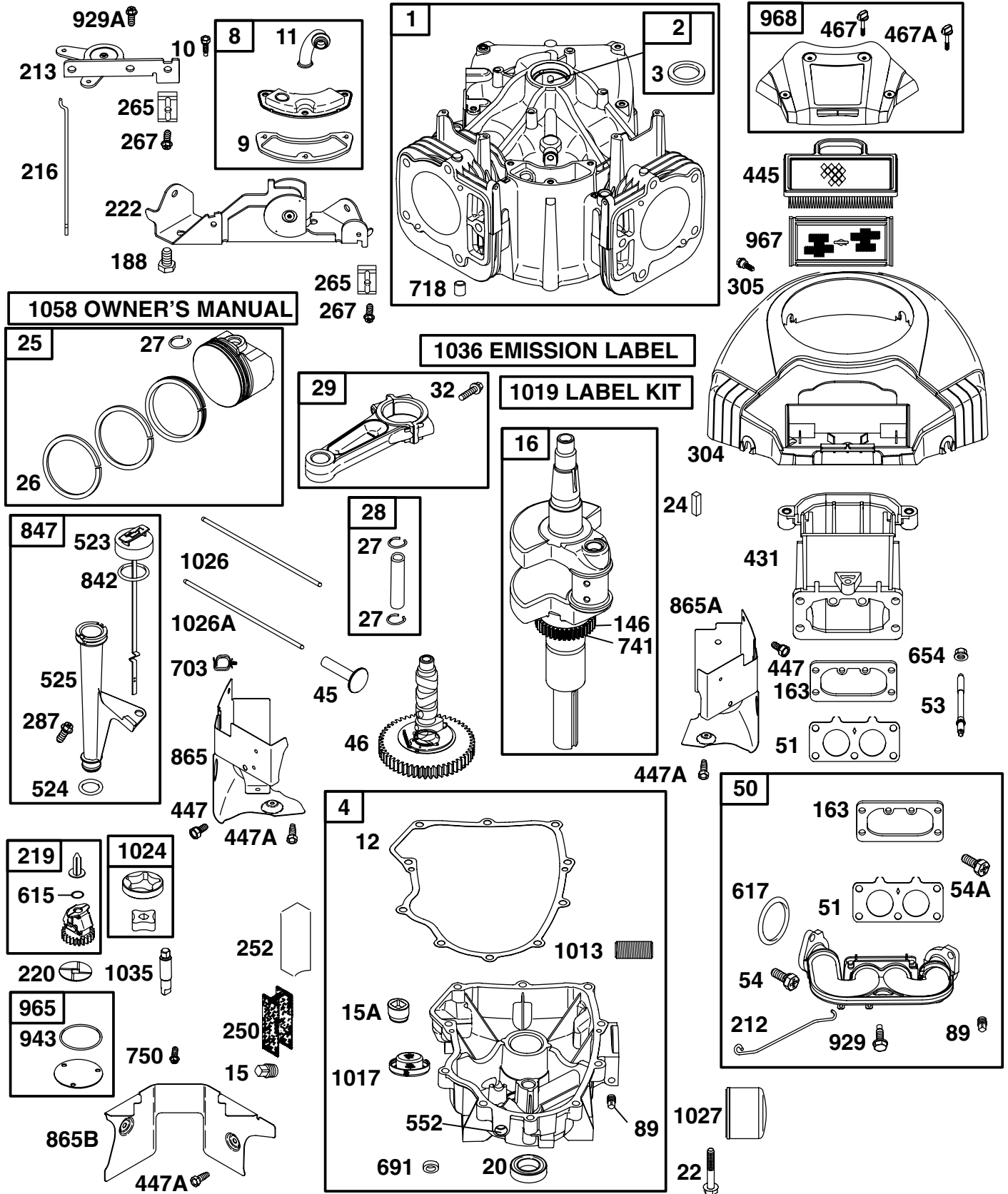

REPAIR PARTS

TRACTOR - - MODEL NUMBER 917.279220

BRIGGS ENGINE - MODEL NUMBER 445677, TYPE NUMBER 0413-E1

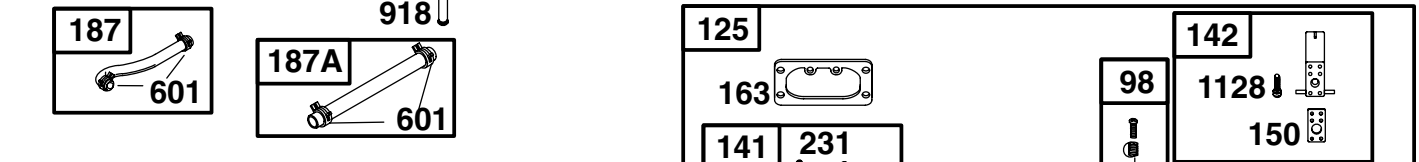
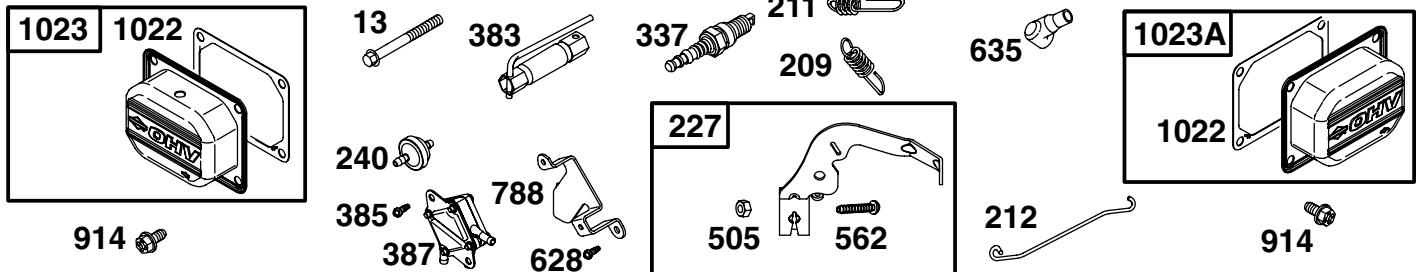
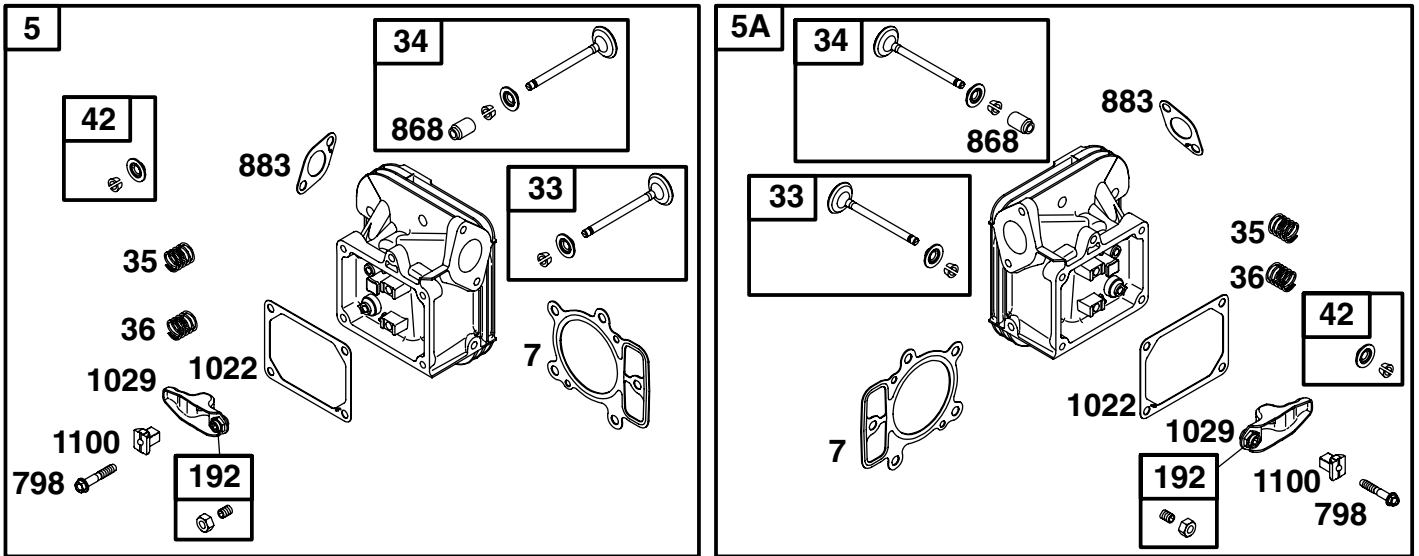

121 CARBURETOR OVERHAUL KIT

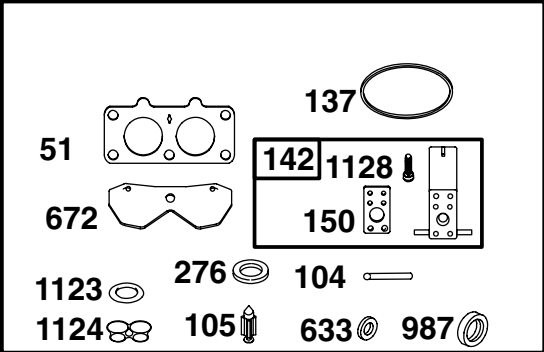

977 CARBURETOR GASKET SET

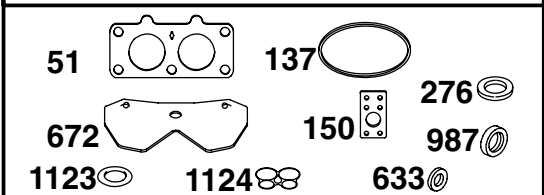

REPAIR PARTS

TRACTOR - - MODEL NUMBER 917.279220

BRIGGS ENGINE - MODEL NUMBER 445677, TYPE NUMBER 0413-E1

1329 REPLACEMENT ENGINE

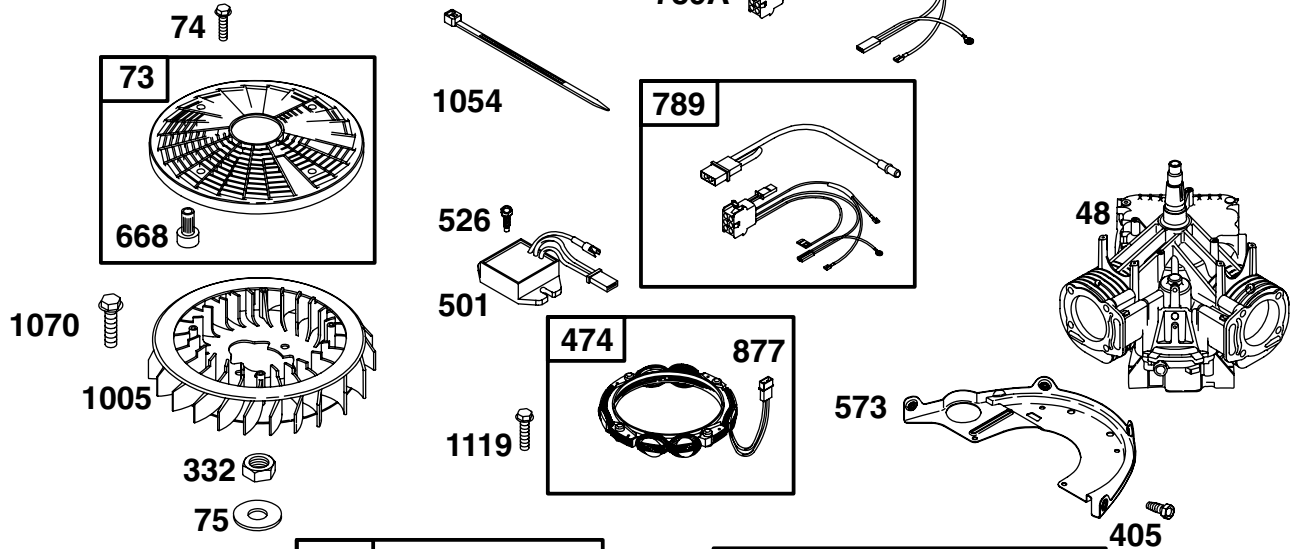

1330 REPAIR MANUAL

1095 VALVE GASKET SET

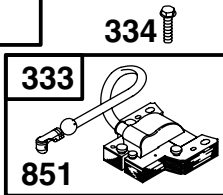
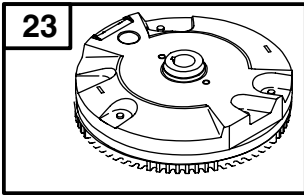
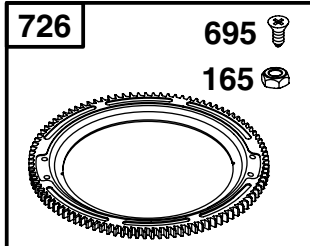
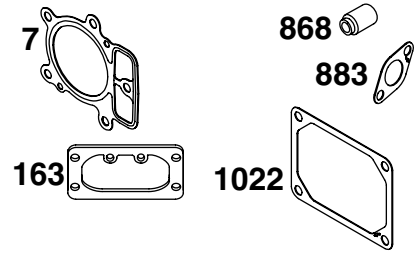

358 ENGINE GASKET SET

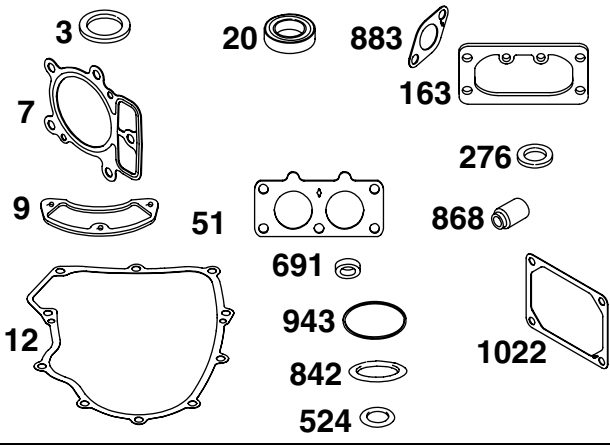

309

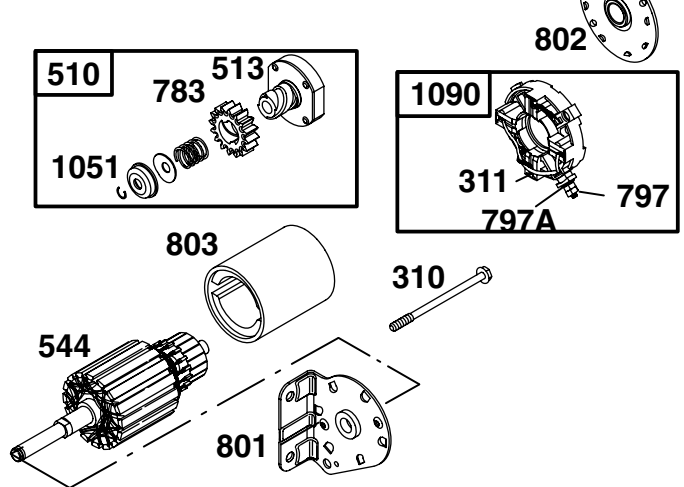

REPAIR PARTS

TRACTOR - - MODEL NUMBER 917.279220

BRIGGS ENGINE - MODEL NUMBER 445677, TYPE NUMBER 0413-E1

KEY NO.	PART NO.	DESCRIPTION	KEY NO.	PART NO.	DESCRIPTION
1	699753	Cylinder Assembly	150	690995	Ø‡ Gasket-Nozzle
2	499585	Kit-Bushing/Seal (Magneto Side)	160	699727	Retainer-Solenoid
3	391086	• Seal-Oil (Magneto Side)	163	691001	•+ Gasket-Air Cleaner
4	699747	Sump-Engine	165	693148	Nut (Ring Gear)
5	693998	Head-Cylinder (Cylinder 1)	187	691049	Line-Fuel
5A	693999	Head-Cylinder (Cylinder 2)	187A	691050	Line-Fuel (Cut to Required Length)
7	693997	•+ Gasket-Cylinder Head	188	691108	Screw (Control Bracket)
8	499601	Breather Assembly	192	690083	Adjuster-Rocker Arm
9	690937	• Gasket-Breather	209	697674	Spring-Governor
10	691108	Screw (Breather Assembly)	211	691019	Spring-Governed Idle
11	690942	Tube-Breather	212	695238	Link-Governor
12	697227	• Gasket-Crankcase	213	691021	Bracket-Choke Control
13	791130	Screw (Cylinder Head)	216	691022	Link-Choke
15	690946	Plug-Oil Drain	219	698231	Gear-Governor
15A	691680	Plug-Oil Drain	220	690412	Washer (Governor Gear)
16	790136	Crankshaft	222	698761	Bracket-Control
20	690947	• Seal-Oil (PTO Side)	227	691048	Lever-Governor Control
22	694966	Screw (Crankcase Cover)	231	690718	Screw (Choke Valve)
23	691053	Flywheel	240	691035	Filter-Fuel
24	222698	Key-Flywheel	250	690957	Retainer-Breather
25	694003	Piston Assembly (Standard)	252	690956	Collector-Oil
	694007	Piston Assembly (.020" Oversize)	265	691024	Clamp-Casing
26	694004	Ring Set (Standard)	267	695134	Screw (Casing Clamp)
	694008	Ring Set (.020" Oversize)	276	690997	•Ø‡Washer-Sealing
27	690975	Lock-Piston Pin	287	691108	Screw (Dipstick/Tube Assembly)
28	690229	Pin-Piston (Standard)	304	790688	Housing-Blower
29	499583	Rod-Connecting (Standard)	305	691005	Screw (Blower Housing)
32	690976	Screw (Connecting Rod)	305A	790690	Screw (Blower Housing)
33	499596	Valve-Exhaust	309	691262	Motor-Starter
34	697464	Valve-Intake	310	691263	Screw (Starter Motor)
35	690963	Spring-Valve (Intake)	311	497608	Brush Set
36	690963	Spring-Valve (Exhaust)	332	691059	Nut (Flywheel)
42	499586	Keeper-Valve	333	691060	Armature-Magneto
45	690977	Tappet-Valve	334	691061	Screw (Magneto Armature)
46	790562	Camshaft	337	691043	Spark Plug
48	698172	Short Block	358	694012	Gasket Set-Engine
50	695241	Manifold-Intake	363	691062	Puller-Flywheel
51	690950	•Ø‡Gasket-Intake	383	690966	Wrench-Spark Plug
53	690951	Stud (Carburetor)	385	690960	Screw (Fuel Pump)
54	695239	Screw (Intake Manifold)	387	808656	Pump-Fuel
54A	699816	Screw (Intake Manifold)	404	690442	Washer (Governor Crank)
73	494439	Screen-Rotating	405	697820	Screw (Back Plate)
74	698425	Screw (Rotating Screen)	418	690999	Plate-Carburetor
75	691056	Washer (Flywheel)	431	790816	Elbow-Intake
89	690283	Plug-Oil	445	499486	Filter-Air Cleaner Cartridge
95	690718	Screw (Throttle Valve)	447	691003	Screw (Air Guide Cover)
98	699721	Kit-Idle Speed	447A	691108	Screw (Air Guide Cover)
104	694918	Ø Pin-Float Hinge	467	691008	Knob-Air Cleaner
105	698537	Ø Valve-Float Needle	467A	790697	Knob-Air Cleaner
108	699723	Valve-Choke	474	696458	Alternator
117	699494	Jet-Main (Standard)	501	691185	Regulator
117A	699495	Jet-Main (Standard)	505	691029	Nut (Governor Control Lever)
121	699734	Kit-Carburetor Overhaul	510	497606	Drive-Starter
125	699709	Carburetor	513	692024	Clutch-Drive
130	690993	Valve-Throttle			
131	499805	Kit-Throttle Shaft			
133	699724	Float-Carburetor			
135	699729	Tube-Fuel Transfer			
137	690994	Ø‡ Gasket-Float Bowl			
146	690979	Key-Timing			

- Included in Engine Gasket Set, Key. No. 358
- Ø Included in Carburetor Overhaul Kit, Key. No. 121
- ‡ Included in Carburetor Gasket Set, Key. No. 977
- + Included in Valve Overhaul Kit, Key. No. 1095

NOTE: All component dimensions given in U.S. inches 1 inch = 25.4 mm

REPAIR PARTS

TRACTOR - - MODEL NUMBER 917.279220

BRIGGS ENGINE - MODEL NUMBER 445677, TYPE NUMBER 0413-E1

KEY NO.	PART NO.	DESCRIPTION	KEY NO.	PART NO.	DESCRIPTION
523	691036	Dipstick	967	273638	Filter-Pre Cleaner
524	691032	• Seal-O Ring (Dipstick Tube)	968	790689	Cover-Air Cleaner
525	691037	Tube-Dipstick	975	499810	Bowl-Float
526	691108	Screw (Regulator)	977	699735	Gasket Set-Carburetor
544		Armature-Starter (Serviced by 691262 Starter Motor Only)	987	691000	Ø‡ Seal-Throttle Shaft
552	690552	Bushing-Governor Crank	1005	790698	Fan-Flywheel
552A	690553	Bushing-Governor Crank	1013	690954	Nipple-Oil Filter
562	690311	Bolt (Governor Control Lever)	1017	690770	Screen-Oil Pump
573	691009	Plate-Back	1019	693995	Kit-Label
601	691038	Clamp-Hose	1022	690971	•+ Gasket-Rocker Cover
615	698290	Retainer-Governor Shaft	1023	499599	Cover-Rocker Arm (Cylinder 1)
616	691045	Crank-Governor	1023A	499600	Cover-Rocker Arm (Cylinder 2)
617	697891	Seal-O Ring (Intake Manifold)	1024	499054	Pump-Oil
628	690960	Screw (Fuel Pump Bracket)	1026	690981	Rod-Push (Steel)
633	690998	Ø‡ Seal-Choke/Throttle Shaft	1026A	690982	Rod-Push (Aluminum)
635	66538	Boot-Sparkplug	1027	492932	Filter-Oil
654	690958	Nut (Carburetor)	1029	690972	Arm-Rocker
668	691215	Spacer	1035	691042	Shaft-Pump
672	690234	Ø‡ Gasket-Carburetor Plate	1036	790625	Label-Emission
691	690657	• Seal-Governor Shaft	1051	691265	Ring-Retaining
695	693149	Screw (Ring Gear)	1054	280275	Cable-Tie
697	690372	Screw (Drive Cap)	1058	275475	Owner's Manual
703	691010	Clip	1070	690372	Screw (Flywheel Fan)
718	690959	Pin-Locating	1090	691293	Retainer-Brush
726	499612	Gear-Ring	1095	694013	Set-Valve Gasket
741	690980	Gear-Timing	1100	690973	Pivot-Rocker Arm
742	690328	Retainer-E Ring	1119	691183	Screw (Alternator)
750	696999	Screw (Oil Pump Cover)	1123	699725	Seal-O Ring (Solenoid Retainer)
783	693058	Gear-Pinion	1124	690988	Ø‡ Seal-O Ring (Fuel Transfer Tube)
788	691039	Bracket-Fuel Pump	1126	690991	Screw (Fuel Transfer Tube)
789	698330	Harness-Wiring	1128	690990	Ø Screw (Carburetor Nozzle)
789A	696576	Harness-Wiring	1329	445777-0027	Replacement Engine (If original engine is equipped with a six pin wiring harness transfer to the replacement engine. Transfer muffler and/or spark arrestor assembly from the original engine if suitable for additional service or add new parts as required. Transfer oil sensor to the replacement engine).
797	691029	Nut (Brush Retainer)			
797A	693167	Nut (Brush Retainer)			
798	697890	Screw (Rocker Arm)			
801	691283	Cap-Drive			
802	691286	Cap-End			
803		Housing-Starter (Serviced by 691262 Starter Motor Only)			
842	691031	• Seal-O Ring (Dipstick)	1330	273521	Repair Manual
847	499602	Assembly-Dipstick/Tube	1342	699731	Extension-Fuel Transfer Tube
851	493880	Terminal-Spark Plug	1353	699725	Seal-O Ring (Fuel Transfer Tube Extension)
855	691011	Adapter-Air Cleaner			
865	691012	Cover-Air Guide (Cylinder 1)			
865A	691014	Cover-Air Guide (Cylinder 2)			
865B	691015	Cover-Air Guide			
868	690968	•+ Seal-Valve			
877	399916	Wire/Connector-Alternator			
883	690970	•+ Gasket-Exhaust			
914	691127	Screw (Rocker Arm Cover)			
918	694000	Hose-Vacuum			
929	695239	Screw (Choke Control Bracket)			
929A	691003	Screw (Choke Control Bracket)			
943	690589	• Seal-O Ring (Oil Pump Cover)			
947	699728	Solenoid-Fuel			
965	499613	Cover-Oil Pump			

NOTE: All component dimensions given in U.S. inches 1 inch = 25.4 mm