

Ride Mower

YTH2454

96043003400

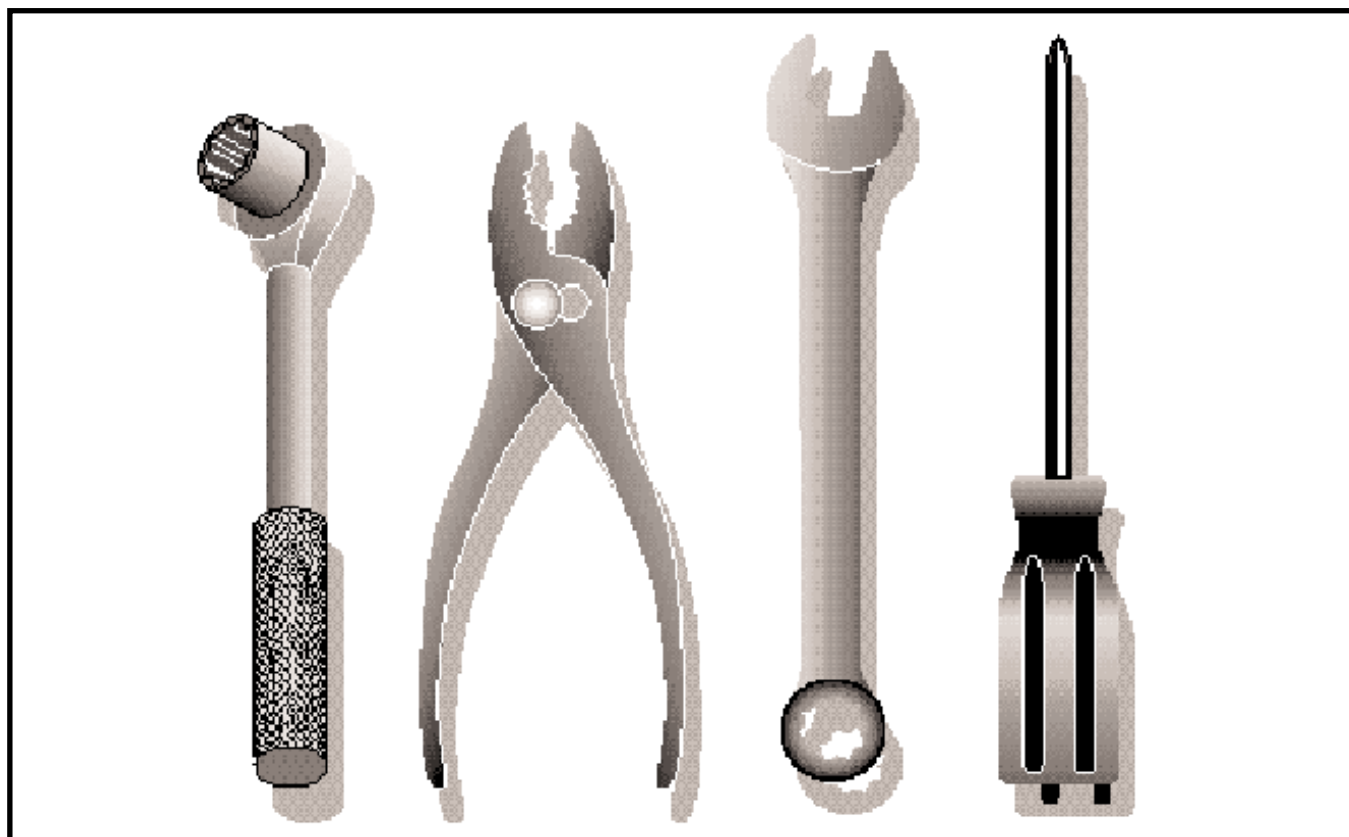

TRACTOR - MODEL NO. YTH2454 (96043003400), PRODUCT NO. 960 43 00-34 SCHEMATIC

02929-194276_Regulated-Tex

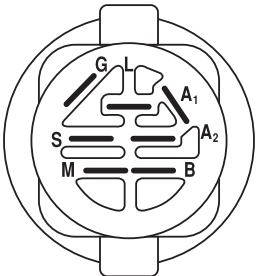
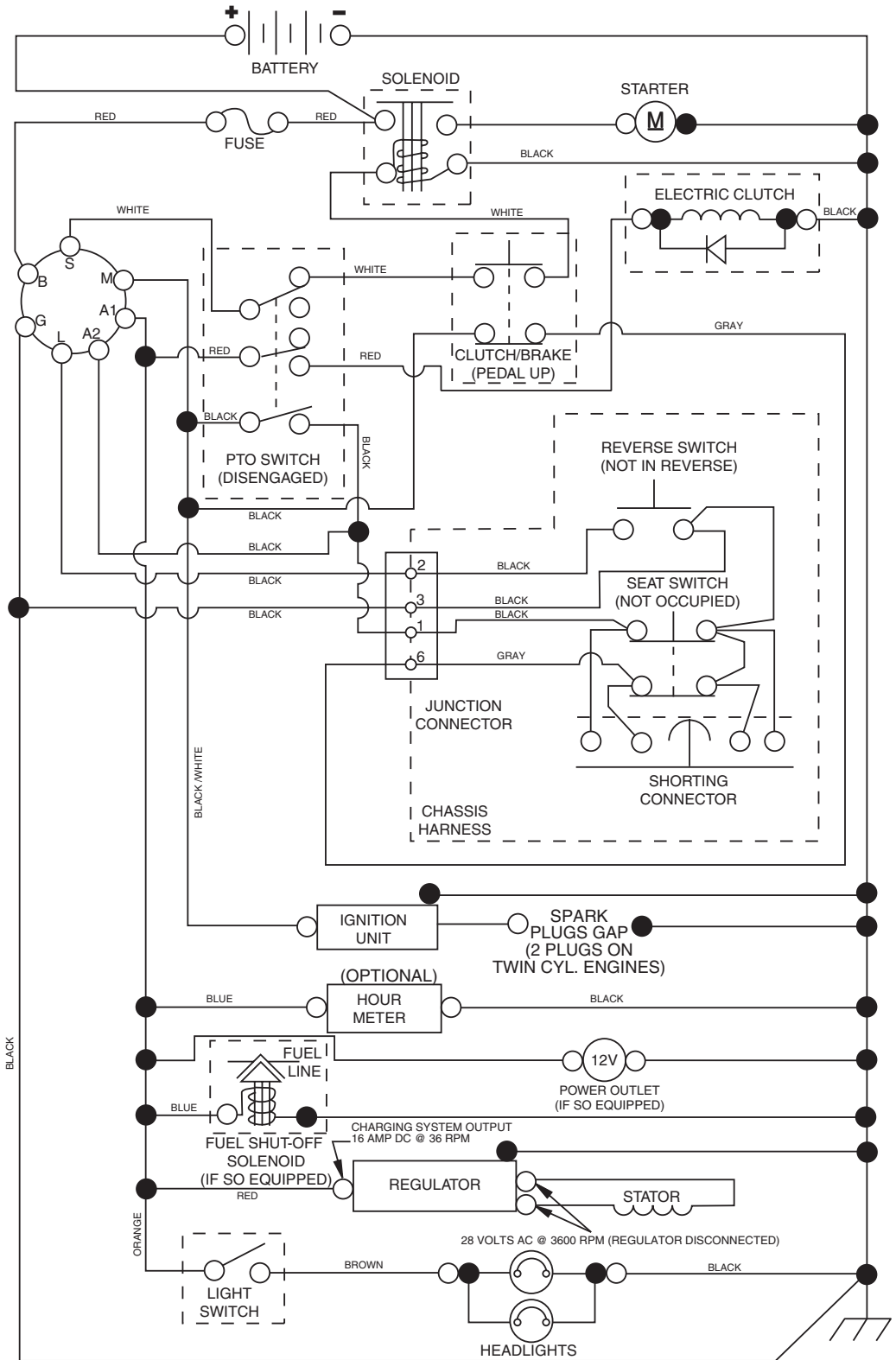

IGNITION SWITCH

POSITION	CIRCUIT	"MAKE"
OFF	M+G+A1	
RUN/OVERRIDE	B+A1	
RUN	B+A1	L+A2
START	B + S + A1	

02929

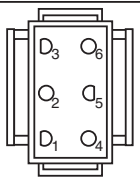

CHASSIS HARNESS CONNECTOR (MATING SIDE)

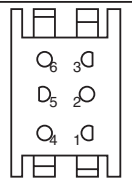

DASH HARNESS CONNECTOR (MATING SIDE)

WIRING INSULATED CLIPS
NOTE: IF WIRING INSULATED CLIPS WERE REMOVED FOR SERVICING OF UNIT, THEY SHOULD BE REPLACED TO PROPERLY SECURE YOUR WIRING.



**TRACTOR - MODEL NO. YTH2454 (96043003400), PRODUCT NO. 960 43 00-34
ELECTRICAL**

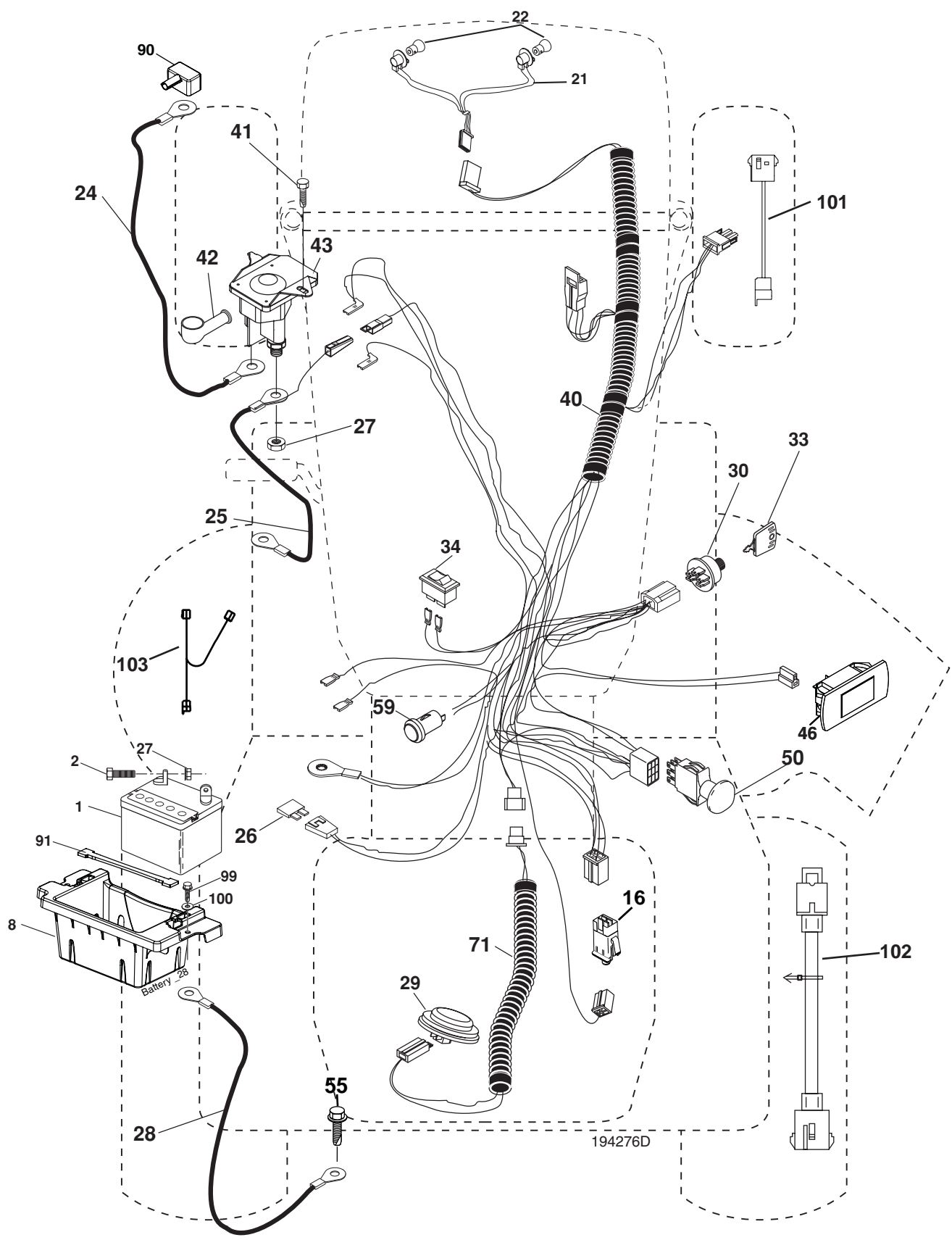

**TRACTOR - MODEL NO. YTH2454 (96043003400), PRODUCT NO. 960 43 00-34
ELECTRICAL**

KEY NO.	PART NO.	DESCRIPTION
1	532 14 49-27	Battery
2	874 76 04-12	Bolt Hex Hd 1/4-20 unc x 3/4
8	532 18 64-91	Battery Box
16	532 17 61-38	Switch Interlock
21	532 18 37-59	Harness Socket Light
22	532 00 41-52	Bulb, Light # 1156
24	532 40 02-53	Cable Battery
25	532 19 88-93	Cable Starter
26	532 17 51-58	Fuse
27	873 51 04-00	Nut Keps Hex 1/4-20 unc
28	532 14 54-91	Cable Ground 21" Blk 6 Ga.
29	532 40 15-45	Switch Seat
30	532 19 33-50	Switch Ign
33	532 14 04-01	Key Ign Molded Generic
34	532 11 07-12	Switch Light/Reset
40	532 40 11-04	Harness Ign. Dash
41	817 72 04-08	Screw Thd Cut 1/4-20 x 1/2
42	532 13 15-63	Cover Terminal Red
43	532 19 25-07	Solenoid
46	532 40 17-63	Gauge Hourmeter
50	532 17 46-51	Switch PTO
55	817 49 05-12	Screw Thdrol 5/16-18 x 3/4
59	532 40 03-03	Outlet 12-Volt
71	532 19 42-76	Harness Ign
90	532 40 07-24	Cover Terminal Battery
91	532 19 02-70	Strap Battery
99	817 67 04-12	Screw Hexwsh Thdrol 1/4-20 x 3/4
100	819 09 14-16	Washer 9/32 x 7/8 x 16 Ga.
101	532 19 83-17	Pigtail MATNLK
102	532 40 44-54	Harness Pigtail K46 Tex ROS
103	532 40 79-62	Harness Pigtail 12V Outlet

NOTE: All component dimensions given in U.S. inches
1 inch = 25.4 mm

**TRACTOR - MODEL NO. YTH2454 (96043003400), PRODUCT NO. 960 43 00-34
CHASSIS**

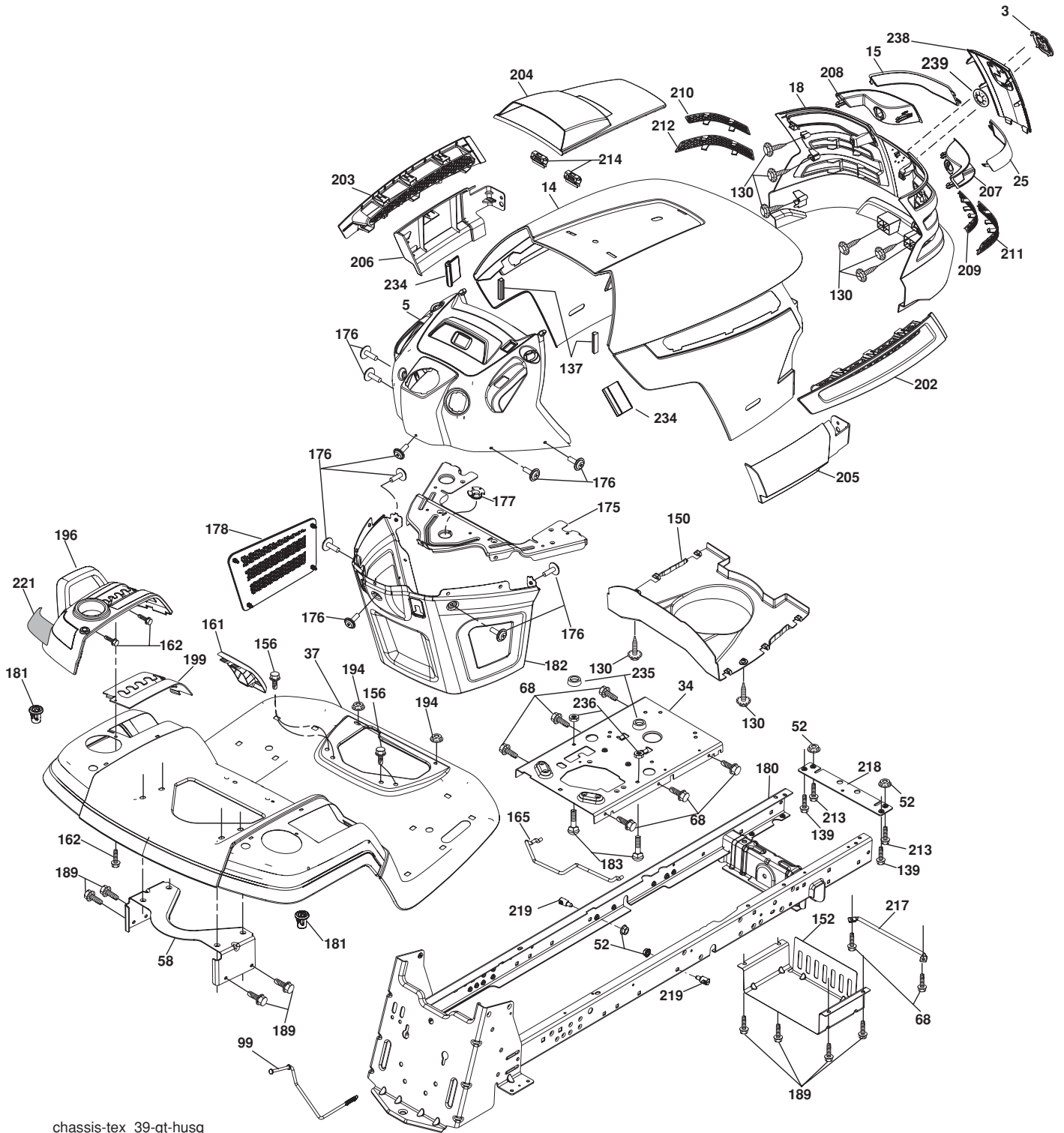

chassis-tex_39-gt-husq

**TRACTOR - MODEL NO. YTH2454 (96043003400), PRODUCT NO. 960 43 00-34
CHASSIS**

KEY NO.	PART NO.	DESCRIPTION
3	532 40 50-12	Logo
5	532 40 87-01	Dash
14	532 41 10-46	Hood
15	532 19 89-07	Lens LH
18	532 40 86-07	Grille
25	532 19 89-06	Lens RH
34	532 19 61-25	Plate Engine
37	532 40 18-25	Fender
52	873 68-05-00	Nut Crown Lock 5/16-18
58	532 19 43-14	Bracket Fender
68	817 49 05-08	Screw 5/16-18 x 1/2
99	532 40 59-17	Rod Bypass Asm.
130	532 19 16-11	Screw 10 x 3/4 Single Lead Hex
137	532 40 75-90	Bumper Dash
139	817 49 05-08	Screw 5/16-18 x 1/2
150	532 19 85-12	Duct Heat Hood
152	532 19 95-35	Shield Browning/Debris
156	817 06 05-12	Screw 5/16-18 x 3/4
161	532 40 18-26	Console Fuel Window
162	532 14 24-32	Screw Hex Wsh Hi-Lo 1/4 x 1/2
165	532 19 68-26	Bracket Support Tank
175	532 19 63-04	Crossmember
176	532 19 32-32	Screw 10-24 x 5/8 Wshd Qdrex
177	532 19 52-27	Bushing Steering
178	532 19 97-82	Cargo Asm. Net
180	532 40 15-59	Chassis
181	532 40 30-25	Bushing Mtg. Fender Crgo.
182	532 19 47-87	Dash Lower
183	873 47 85-20	Bolt 5/16-18 UNC x 1-1/4

KEY NO.	PART NO.	DESCRIPTION
189	817 00 05-12	Screw 5/16-18 x 3/4
194	873 80 05-00	Nut Lock Hex Flange 5/16-18
196	532 40 02-99	Console Asm. Deck Lift
199	532 19 82-59	Plate Deck Lift
202	532 40 30-48	Vent Side Hood RH
203	532 40 30-76	Vent Side Hood LH
204	532 19 89-04	Vent Asm Hood Top
205	532 40 17-09	Skirt Hood Side RH
206	532 40 17-11	Skirt Hood Side LH
207	532 19 71-98	Bezel RH
208	532 19 71-99	Bezel LH
209	532 19 91-30	Insert Hex Top RH
210	532 19 91-31	Insert Hex Top LH
211	532 19 91-32	Insert Hex Bottom RH
212	532 19 91-33	Insert Hex Bottom LH
213	874 76 05-12	Bolt Hex Hd 5/16-18 unc x 3/4
214	532 19 91-45	Clip Retainer
217	532 15 65-24	Rod Pivot
218	532 19 63-95	Hood Stop
219	532 19 51-61	Stud Fastener
221	532 19 89-09	Reflector LH
234	532 40 47-42	Bumper Hood
235	532 40 61-29	Spacer Fender
236	873 93 05-00	Nut Center Lock 5/16-18 UNC
238	532 40 86-06	Trim
239	532 11 04-52	Nut Push

NOTE: All component dimensions given in U.S. inches
1 inch = 25.4 mm

TRACTOR - MODEL NO. YTH2454 (96043003400), PRODUCT NO. 960 43 00-34
DRIVE

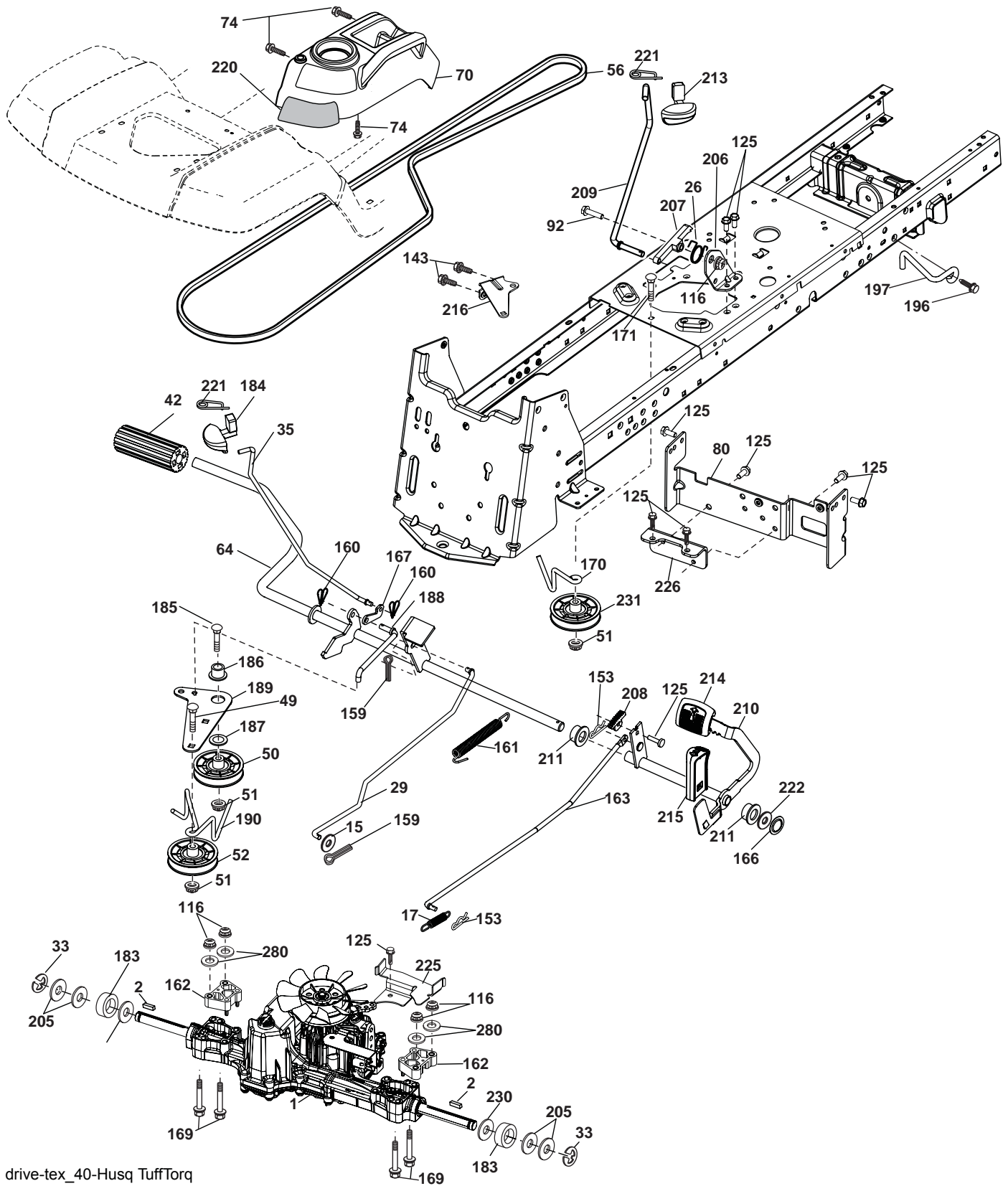

drive-tex_40-Husq TuffTorq

**TRACTOR - MODEL NO. YTH2454 (96043003400), PRODUCT NO. 960 43 00-34
DRIVE**

KEY NO.	PART NO.	DESCRIPTION	KEY NO.	PART NO.	DESCRIPTION
1	532 40 40-47	Transaxle, TUFFTORQ K46 (Internal parts not available)	170	532 19 43-22	Keeper Belt Centerspan
2	532 12 35-83	Key	171	872 11 06-22	Bolt 3/8 - 16 x 2-3/4 Gr. 5
7	532 19 98-44	Hub Asm. Wheel	183	532 13 70-57	Spacer Split
9	532 14 00-80	Bolt Hub Wheel	184	532 40 31-18	Handle Parking Brake
15	819 13 13-16	Washer 13/32 x 13/16 x 16 Ga.	185	872 11 06-20	Bolt Rdhd Sqnk 3/8-16 x 2-1/2
17	532 40 10-72	Spring, Brake	186	532 19 43-21	Spacer Retainer
26	532 19 96-79	Spring Return Cruise	187	819 13 32-10	Washer
29	532 40 38-06	Rod, Brake	188	532 19 43-23	Link Clutch Ground Drive
33	812 00 00-01	Ring E	189	532 19 43-17	Bellcrank Ground Drive
35	532 19 95-91	Rod, Brake, Park	190	532 19 43-18	Keeper Bellcrank Ground Drive
42	532 12 48-72	Cover, Foot Pedal	196	817 00 06-16	Screw 3/8-16 x 1
49	872 11 06-14	Bolt	197	532 19 97-69	Bracket Clutch Anti-Rotation
50	532 19 43-27	Pulley Idler Flat	205	532 12 17-48	Washer
51	873 90 06-00	Lock Nut 3/8-16	206	532 19 78-67	Bracket Mount Latch Cruise
52	532 19 43-26	Idler V-Groove 910" Offset	207	532 19 78-68	Latch Control Cruise
56	532 13 09-69	V-Belt, Drive	208	532 19 78-69	Gear Sector Control Cruise
64	532 19 78-65	Shaft Asm. Pedal Brake Control	209	532 19 95-92	Rod Control Cruise
70	532 40 05-30	Console Asm.	210	532 19 78-60	Rocker Asm. Pedal Control
74	532 14 24-32	Screw 1/4 x 1/2	211	532 12 01-83	Bearing Nylon
80	532 41 00-24	Strap Torque	213	532 40 31-19	Knob Control Cruise
92	874 76 05-20	Bolt Fin Hex 5/16-18 unc x 1.25	214	532 40 17-22	Pedal Forward
116	873 90 05-00	Nut Lock Hex Flange 5/16-18	215	532 40 17-23	Pedal Reverse
125	817 00 05-12	Screw 5/16-18 x 3/4	216	532 19 61-31	Bracket Pulley Idler
143	817 49 05-08	Screw Thdrol 5/16-18 x 1/2	220	532 19 89-08	Reflector RH
153	532 12 47-88	Retainer Spring	221	532 40 31-87	Retainer Spring Clip Handle
159	876 02 04-12	Pin Cotter 1/8 x 3/4	222	819 21 20-10	Washer 21/32 x 1-1/4 x 10 Ga.
160	532 16 94-84	Retainer Clip	225	532 40 33-19	Keeper Belt Trans.
161	532 19 54-03	Spring, Return, Clutch	226	532 40 15-64	Bracket Mount Touque
162	532 41 09-63	Spacer Transaxle	230	532 18 89-67	Washer
163	532 40 10-34	Rod Pedal Control	231	532 40 72-87	Idler V-Groove Pulley
166	532 19 72-90	Nut Push .625	280	819 11 10-12	Washer 11/32 x 5/8 x 12 Ga.
167	532 40 52-57	Latch Brake Parking			
169	874 78 05-72	Bolt 5/16-18 x 4.5 Gr. 5			

NOTE: All component dimensions given in U.S. inches
1 inch = 25.4 mm

**TRACTOR - MODEL NO. YTH2454 (96043003400), PRODUCT NO. 960 43 00-34
ENGINE**

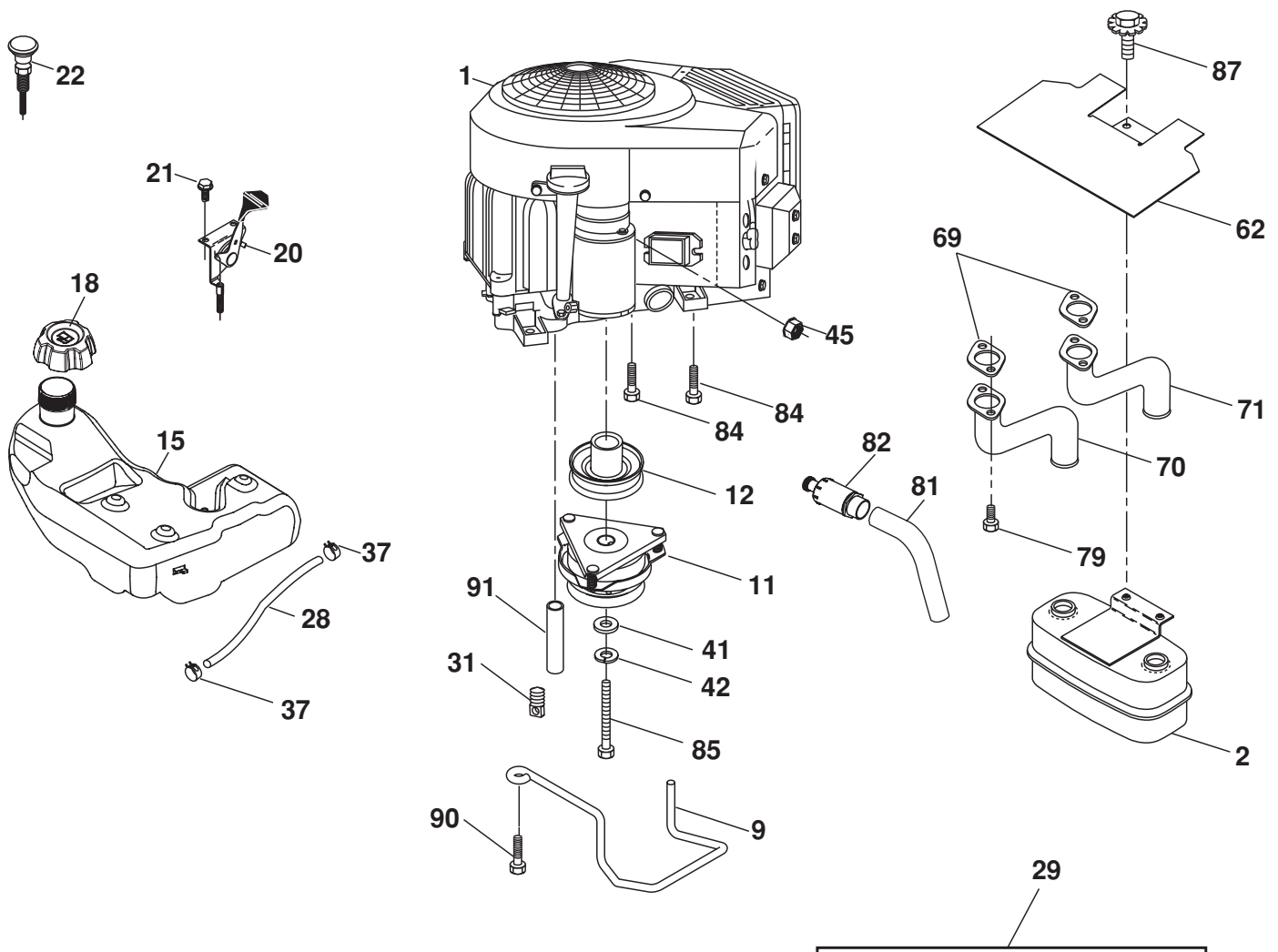

SPARK ARRESTER KIT

engine-tex_7-vgt

TRACTOR - MODEL NO. YTH2454 (96043003400), PRODUCT NO. 960 43 00-34 ENGINE

KEY NO.	PART NO.	DESCRIPTION
1	-----	Engine Briggs Model No. 445677
2	532 14 97-23	Muffler
9	532 19 43-20	Keeper Belt Engine
11	532 17 93-35	Clutch Electric
12	532 19 43-43	Pulley Engine
15	532 19 34-99	Tank Fuel 4.0
18	532 19 42-67	Cap Asm
20	532 17 83-85	Control Throttle
21	532 19 16-11	Screw 10 x 3/4 Single Lead Hex
22	532 19 15-96	Control Choke
28	532 40 11-35	Fuel Line
29	532 13 71-80	Spark Arrester Kit
31	532 14 50-06	Clip Push-In
37	532 12 34-87	Clamp Hose
41	532 12 61-97	Washer 1-1/2 OD x 15/32 ID x .250
42	810 04 07-00	Washer Lock 7/16
45	873 51 04-00	Nut Keps Hex 1/4-20 unc
62	532 14 66-29	Shield Heat Muffler
69	532 16 53-91	Gasket
70	532 15 99-55	Tube Exhaust LH

KEY NO.	PART NO.	DESCRIPTION
71	532 16 05-89	Tube Exhaust RH
79	532 18 39-06	Screw Socket Head 5/16-18 x 1
81	532 14 84-56	Tube Drain Oil Easy
82	532 18 16-54	Plug Drain Oil
84	817 06 06-20	Screw 3/8-16 x 1-1/4
85	532 17 99-53	Bolt Hex 7/16-20 x 3.75 Gr. 5
87	532 19 82-39	Bolt 5/16-18 unc x 1 w/Sems
90	817 00 06-16	Screw 3/8-16 x 1
91	532 18 74-95	Bushing

NOTE: All component dimensions given in U.S. inches
1 inch = 25.4 mm

For engine service and replacement parts, call the toll free number for your engine manufacturer listed below:

Briggs & Stratton	1-800-233-3723
Kohler Co.	1-800-544-2444
Tecumseh Products	1-800-558-5402
Honda Engines	1-800-426-7701
Kawasaki	1-949-460-5688

ENGINE POWER RATING INFORMATION

The gross power rating for individual gas engine models is labeled in accordance with SAE (Society of Automotive Engineers) code J11940 (Small Engine Power & Torque Rating Procedure), and rating performance has been obtained and corrected in accordance with SAE J1995 (Revision 2002-5). Actual gross engine power will be lower and is affected by, among other things, ambient operating conditions and engine-to-engine variability. Given both the wide array of products on which engines are placed and the variety of environmental issues applicable to operating the equipment, the gas engine will not develop the rated gross power when used in a given piece of power equipment (actual "on-site" or net horsepower). This difference is due to a variety of factors including, but not limited to, accessories (air cleaner, exhaust, charging, cooling, carburetor, fuel pump, etc.), application limitations, ambient operating conditions (temperature, humidity, altitude), and engine-to-engine variability. Due to manufacturing and capacity limitations, Briggs & Stratton may substitute an engine of higher rated power for this Series engine.

**TRACTOR - MODEL NO. YTH2454 (96043003400), PRODUCT NO. 960 43 00-34
STEERING ASSEMBLY**

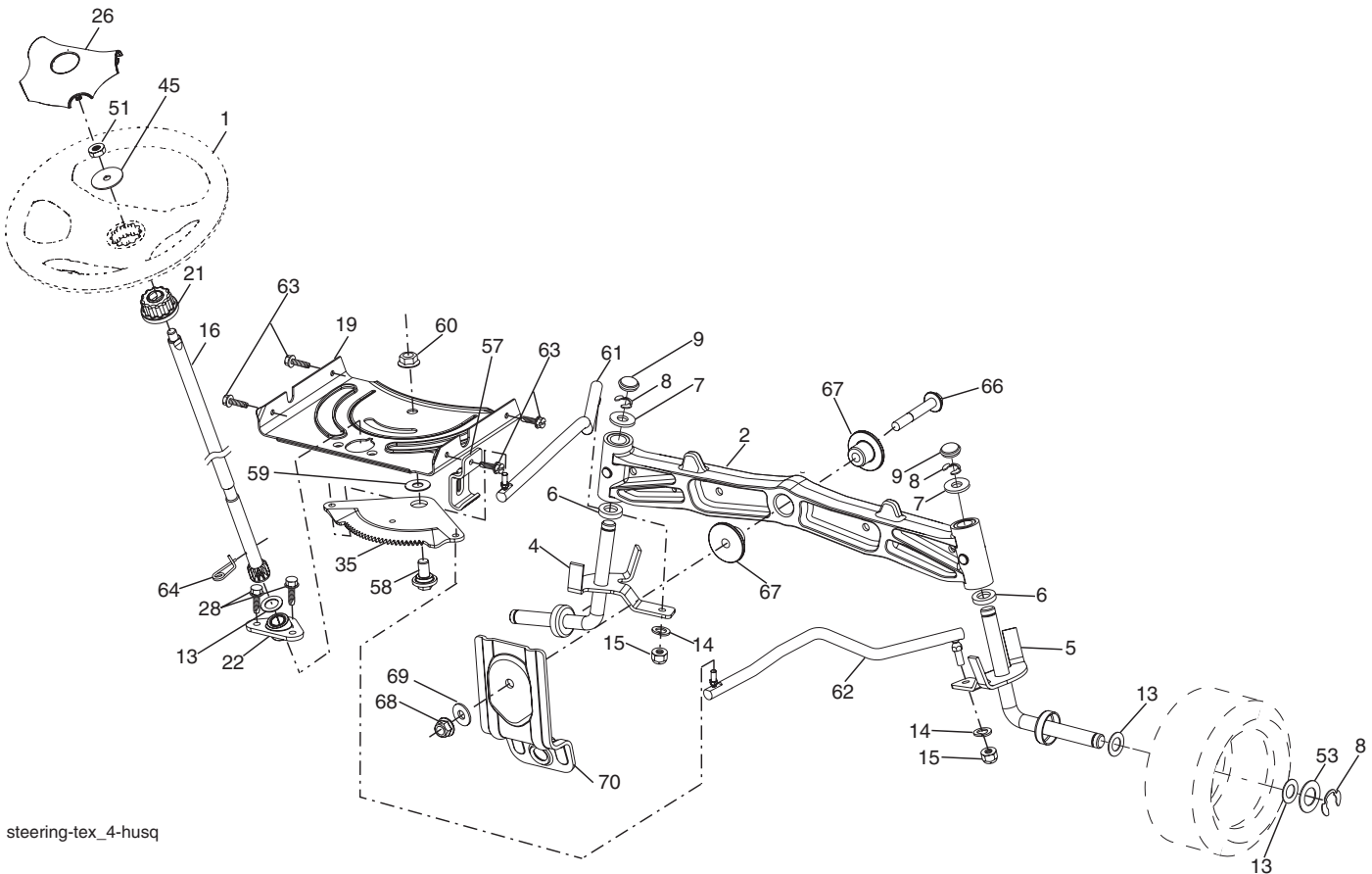

steering-tex_4-husq

KEY NO.	PART NO.	DESCRIPTION
1	532 19 39-43	Wheel, Steering
2	532 19 59-68	Axle Asm., Front
4	532 40 30-89	Spindle Asm., LH
5	532 40 30-90	Spindle Asm., RH
6	532 12 49-31	Bearing, Race Thrust Harden
7	532 12 17-48	Washer 25/32 x 1-5/8 x 16 Ga.
8	812 00 00-29	Ring, Klip #T5304-75
9	532 12 12-32	Cap, Spindle
13	532 12 17-49	Washer 25/32 x 1-1/4 x 16 Ga.
14	810 04 06-00	Washer, Lock Hvy Hlcl Spr 3/8
15	873 54 06-00	Nut, Crown Lock 3/8-24 unf
16	532 19 47-46	Shaft Steering
19	532 19 47-29	Plate Steering
21	532 18 67-37	Adapter, Wheel Steering
22	532 19 48-45	Bushing, Strg. Blk
26	532 19 36-52	Insert, Wheel Steering
28	817 00 06-12	Screw 3/8-16 x 3/4
35	532 19 47-32	Gear, Sector Plate
45	819 18 38-12	Washer 9/16 x 2-3/8 x 12 Ga.

KEY NO.	PART NO.	DESCRIPTION
51	873 94 08-00	Nut Hex Jam Toplock 1/2-20 unf
53	532 18 89-67	Washer Hardened .793 x 1.637 x .060
57	532 19 72-46	Bracket Upstop
58	532 19 47-47	Bolt Shoulder Sector Pivot CFM
59	532 19 47-48	Washer Thrust Sector Steering
60	873 97 10-00	Nut Flange Lock 5/8-11
61	532 19 47-40	Draglink LH
62	532 19 47-41	Draglink, RH
63	817 00 05-12	Screw 5/16-18 x 3/4
64	532 19 98-49	Retainer Clip Spring Steering
66	871 02 07-48	Bolt Hex Fghd 7/16-14 x 3 Serr
67	532 19 47-37	Bushing PM Front Axle
68	873 90 07-00	Nut Lock Flange 7/16-14 Gr. 5
69	532 19 91-62	Washer 1.5 x .505 x .118
70	532 19 61-97	Bracket Deck Susp. Front

NOTE: All component dimensions given in U.S. inches
1 inch = 25.4 mm

**TRACTOR - MODEL NO. YTH2454 (96043003400), PRODUCT NO. 960 43 00-34
SEAT ASSEMBLY**

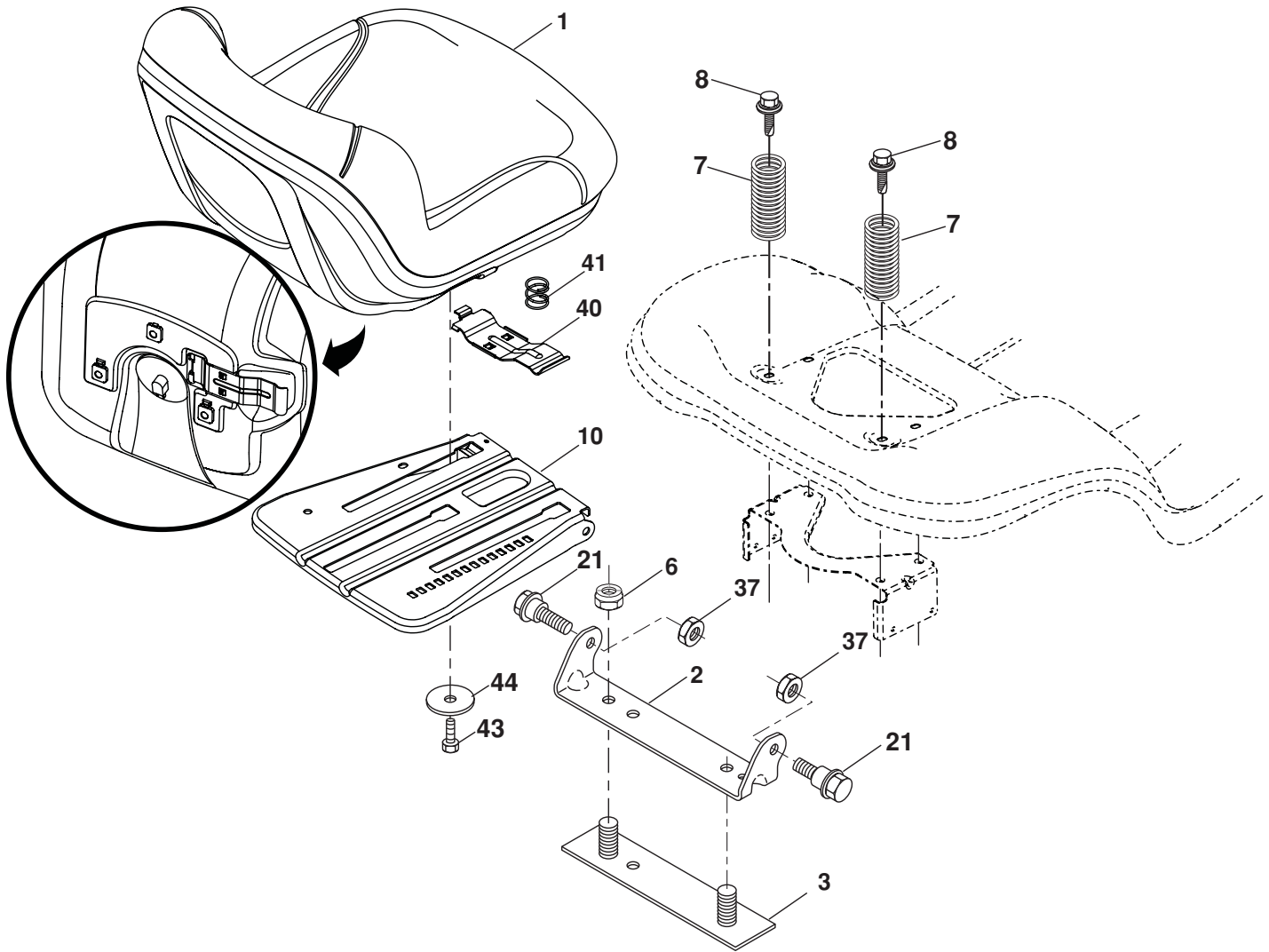

seat-tex_7-vgt

KEY NO.	PART NO.	DESCRIPTION
1	532 40 66-21	Seat
2	532 18 01-66	Bracket Pivot Fender
3	532 14 06-75	Strap, Asm Fender
6	873 80 06-00	Nut, Lock W/Ins. 3/8-16 unc
7	532 12 41-81	Spring, Seat Cprsn
8	532 17 18-77	Bolt 5/16-18 uncx 3/4 w/Sems
10	532 19 69-77	Pan, Seat
21	532 17 18-52	Bolt, Shoulder 5/16-18

KEY NO.	PART NO.	DESCRIPTION
37	873 80 05-00	Nut, Lock 5/16-18 unc
40	532 19 76-61	Handle Slide Seat
41	532 19 82-00	Spring Latch Seat
43	874 76 06-12	Bolt 3/8-16 x 3/4
44	819 13 38-12	Washer 13/32 x 2-3/8 x 12 Ga.

NOTE: All component dimensions given in U.S. inches
1 inch = 25.4 mm

TRACTOR - MODEL NO. YTH2454 (96043003400), PRODUCT NO. 960 43 00-34
MOWER DECK

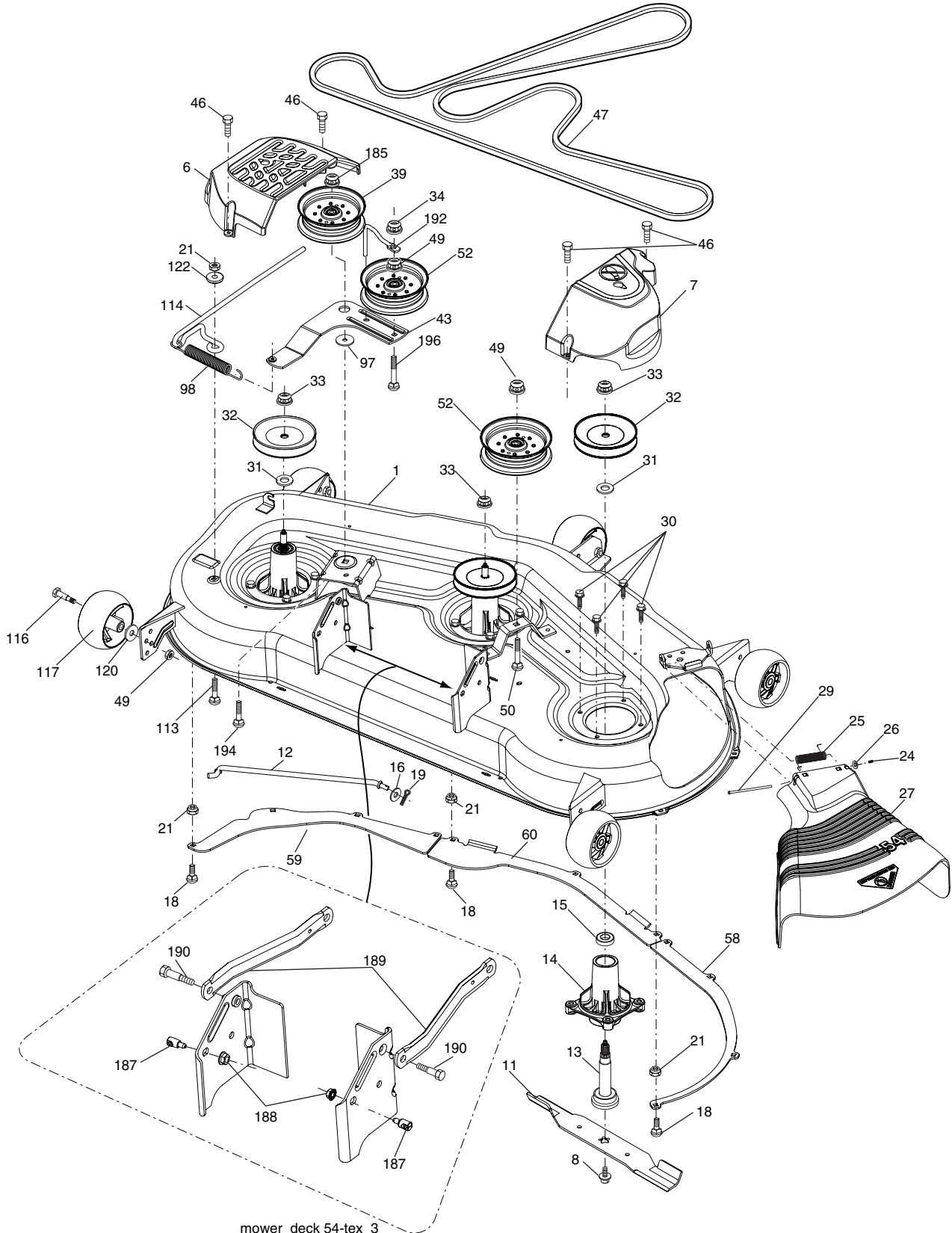

mower_deck 54-tex_3

**TRACTOR - MODEL NO. YTH2454 (96043003400), PRODUCT NO. 960 43 00-34
MOWER DECK**

KEY NO.	PART NO.	DESCRIPTION
1	532 40 31-25	Deck Weldment Mower
6	532 19 60-66	Cover Mandrel LH
7	532 19 71-81	Cover Mandrel RH
8	532 17 43-65	Bolt 7/16 Asm. Blade
11	532 18 72-56	Blade Bagging
--	532 18 72-55	Blade Mulching
--	532 18 72-54	Blade Hi-Lift
12	532 40 48-51	Rod Anti Sway
13	532 18 72-91	Shaft Asm. w/Lower Bearing
14	532 18 72-81	Housing, Mandrel
16	819 13 13-12	Washer 3/8
15	532 11 04-85	Bearing, Ball, Mandrel
18	872 14 05-05	Bolt Carriage 5/16-18 x 5/8
19	532 19 42-08	Pin Cotter 5/16 Bowtie
21	873 68 05-00	Nut, Crownlock 5/16-18 unc
24	532 10 53-04	Cap Sleeve
25	532 17 81-02	Spring, Torsion
26	532 11 04-52	Nut, Push
27	532 18 89-38	Deflector Shield
29	532 13 14-91	Rod, Hinge
30	532 17 39-84	Screw, Thdroll Washer Head
31	532 18 76-90	Washer, Spacer Mower Vented
32	532 17 34-36	Pulley, Mandrel
33	532 40 02-34	Nut, Flg. Top Lock
34	873 68 06-00	Nut Crownlock 3/8-16 unc
39	532 19 61-04	Pulley, Idler, Stationary LH
43	532 19 60-65	Arm, Idler
46	532 13 77-29	Screw, Thdroll. 1/4-20 x 5/8
47	532 19 61-03	Belt Deck Drive

KEY NO.	PART NO.	DESCRIPTION
49	873 90 06-00	Nut, Lock Flg. 3/8-16 unc
50	872 11 06-16	Bolt Rdhd Sqnk 3/8-16 unc x 2
52	532 19 61-06	Pulley Idler
58	532 18 73-42	Baffle Right
59	532 18 73-44	Baffle Left
60	532 18 76-07	Baffle Center
97	532 17 85-15	Washer Hardened
98	532 19 61-05	Spring Drive
113	872 11 05-08	Bolt Rdhd Sqnk 5/16-18 x 3/4
114	532 18 75-56	Rod Tension Relief
116	532 19 34-06	Bolt, Shoulder
117	532 17 48-73	Gauge Wheel
120	819 13 20-12	Washer 13/32 x 1-1/4 x 12 Ga.
122	532 18 75-57	Bushing Tension Relief
185	873 90 07-00	Nut Lock Flange 7/16-14 Gr. 5
187	532 19 51-61	Stud Fastener w/"D" Anti-Rotation
188	873 90 05-00	Nut Lock Hex Flange
189	532 19 51-85	Arm Susp. Mower Rear
190	532 19 65-39	Bolt Shoulder
192	532 19 84-68	Keeper Belt Idler
194	872 14 07-16	Bolt Carr Sqnk 7/16-24 x 2
196	872 14 06-20	Bolt Rdhd 3/8-16 x 2-1/2 Gr. 5
--	532 18 72-92	Mandrel Asm. Service (Includes Key Nos. 13-15 and 33)
--	532 19 93-00	Replacement Mower, Complete

NOTE: All component dimensions given in U.S. inches
1 inch = 25.4 mm

**TRACTOR - MODEL NO. YTH2454 (96043003400), PRODUCT NO. 960 43 00-34
DECALS**

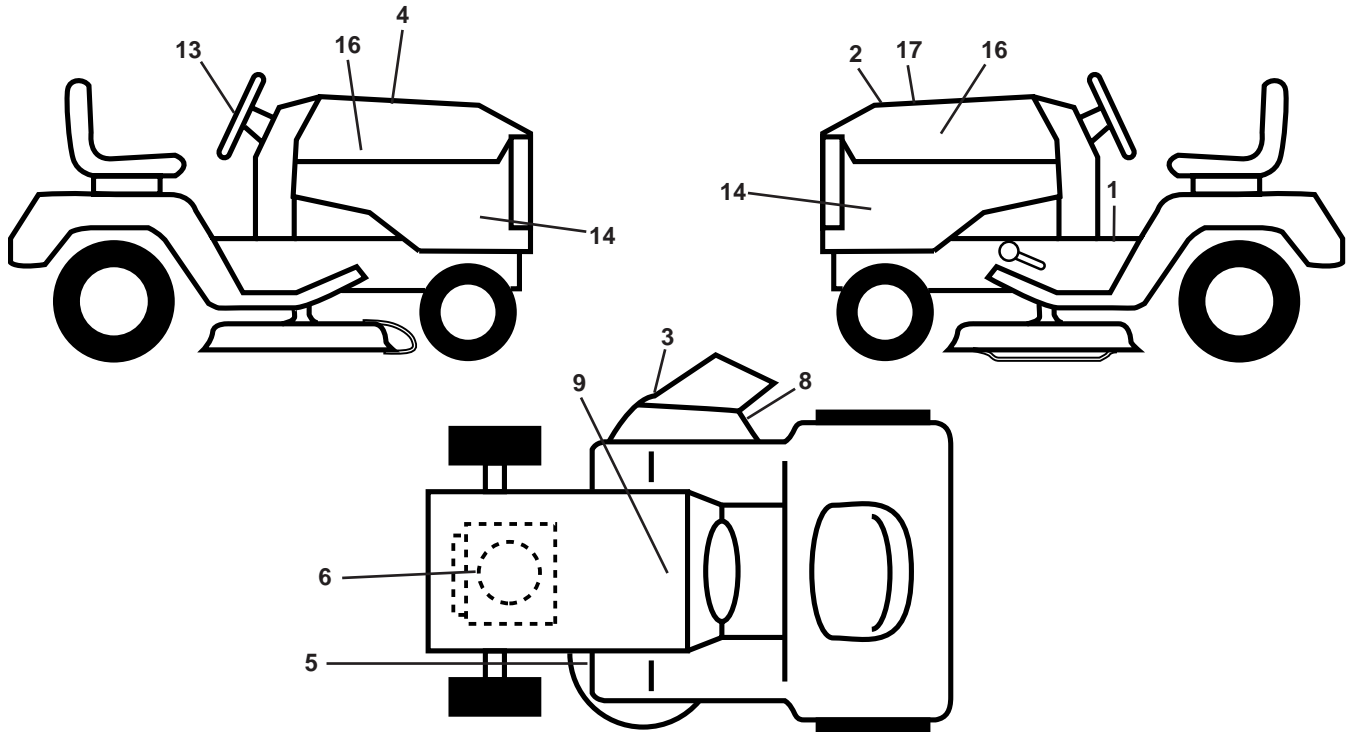

KEY NO.	PART NO.	DESCRIPTION
1	532 40 21-04	Decal, Operator's
2	532 40 21-28	Decal, Hood Insert
3	532 17 05-63	Decal, Warning
4	532 18 09-41	Decal, Hood Cust Resp
5	532 17 85-02	Decal, Caution
6	532 40 88-42	Decal, Eng. HP
8	532 19 87-85	Decal, Mower Sch.
9	532 14 50-05	Decal, Battery Dnge/Poi

KEY NO.	PART NO.	DESCRIPTION
13	532 40 44-84	Decal, Steering Whl
14	532 41 05-01	Decal, Panel Side
16	532 40 28-32	Decal, Hood Logo
17	532 40 99-94	Decal, Replacement
--	532 16 69-60	Decal, Bypass
--	532 40 17-71	Pad, Footrest, LH
--	532 40 37-73	Pad, Footrest, RH
--	532 40 97-67	Manual, Owner's (Eng)
--	532 40 97-68	Manual, Owner's (Fr)

WHEELS AND TIRES

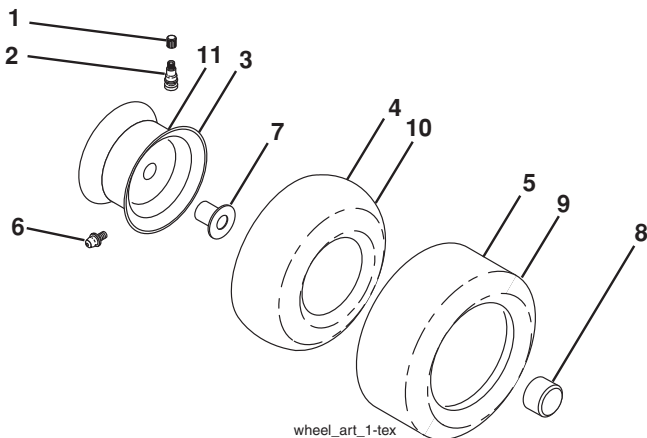

wheel_art_1-tex

KEY NO.	PART NO.	DESCRIPTION
1	532 05 91-92	Cap, Valve, Tire
2	532 06 51-39	Stem, Valve
3	532 14 45-09	Rim Assembly, Front
4	532 05 99-04	Tube, Front (Service Item Only)
5	532 10 62-30	Tire, Front
6	532 12 49-57	Fitting, Grease (Front Wheel Only)
7	532 12 49-59	Bearing, Flange (Front Wheel Only)
8	532 17 50-39	Cap, Axle (Front Wheel Only)
9	532 12 20-82	Tire, Rear
10	532 12 49-26	Tube, Rear (Service Item Only)
11	532 13 83-37	Rim Assembly, Rear
--	532 14 43-34	Sealant, Tire (10 oz. Tube)

NOTE: All component dimensions given in U.S. inches
1 inch = 25.4 mm

**TRACTOR - MODEL NO. YTH2454 (96043003400), PRODUCT NO. 960 43 00-34
MOWER LIFT**

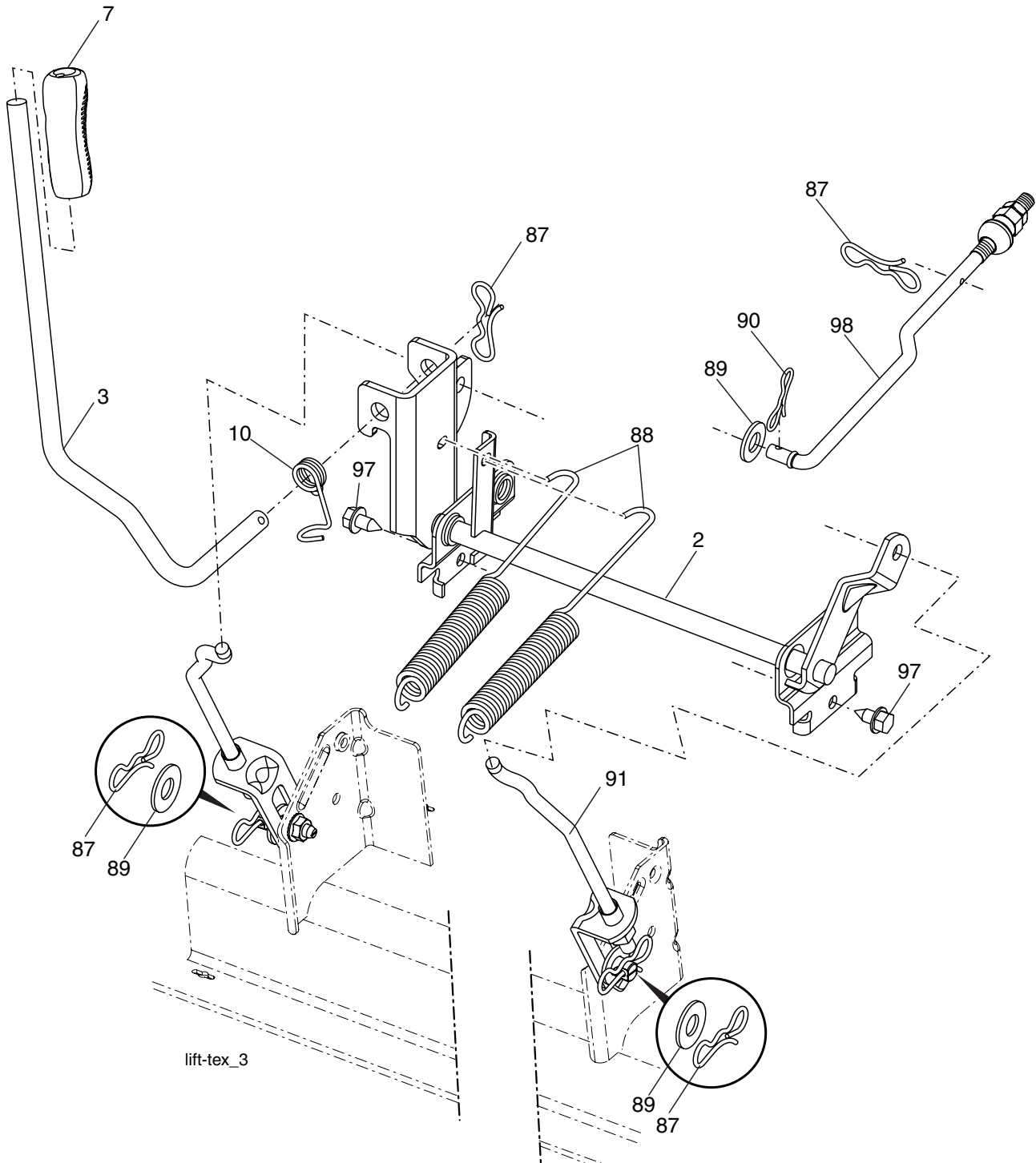

KEY NO.	PART NO.	DESCRIPTION
2	532 19 52-23	Shaft Asm., Lift
3	532 19 52-30	Lever Asm., Lift Rh
7	532 41 15-55	Grip, Lever
10	532 19 63-14	Spring Torsion
87	532 19 42-09	Pin Cotter 7/16 Bow Tie Lock
88	532 19 53-04	Spring Lift Assist
89	819 19 19-12	Washer Clear Zinc

KEY NO.	PART NO.	DESCRIPTION
90	532 19 42-08	Pin Cotter 5/16 Bow Tie Lock
91	532 40 34-07	Link Lift Susp Mower Rear
97	817 06 06-12	Screw 3/8-16 x .75 Smgml Tap/R.Z
98	532 19 52-64	Link Lift Susp. Front Mower

NOTE: All component dimensions given in U.S. inches
1 inch = 25.4 mm