

Ride Mower

GTH26K54

96043003100



TRACTOR - MODEL NO. GTH26K54 (96043003100), PRODUCT NO. 960 43 00-31 SCHEMATIC

02929-194276_Regulated-Tex

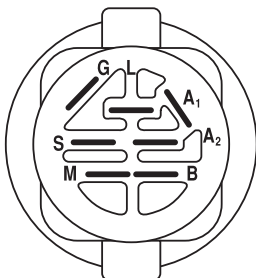
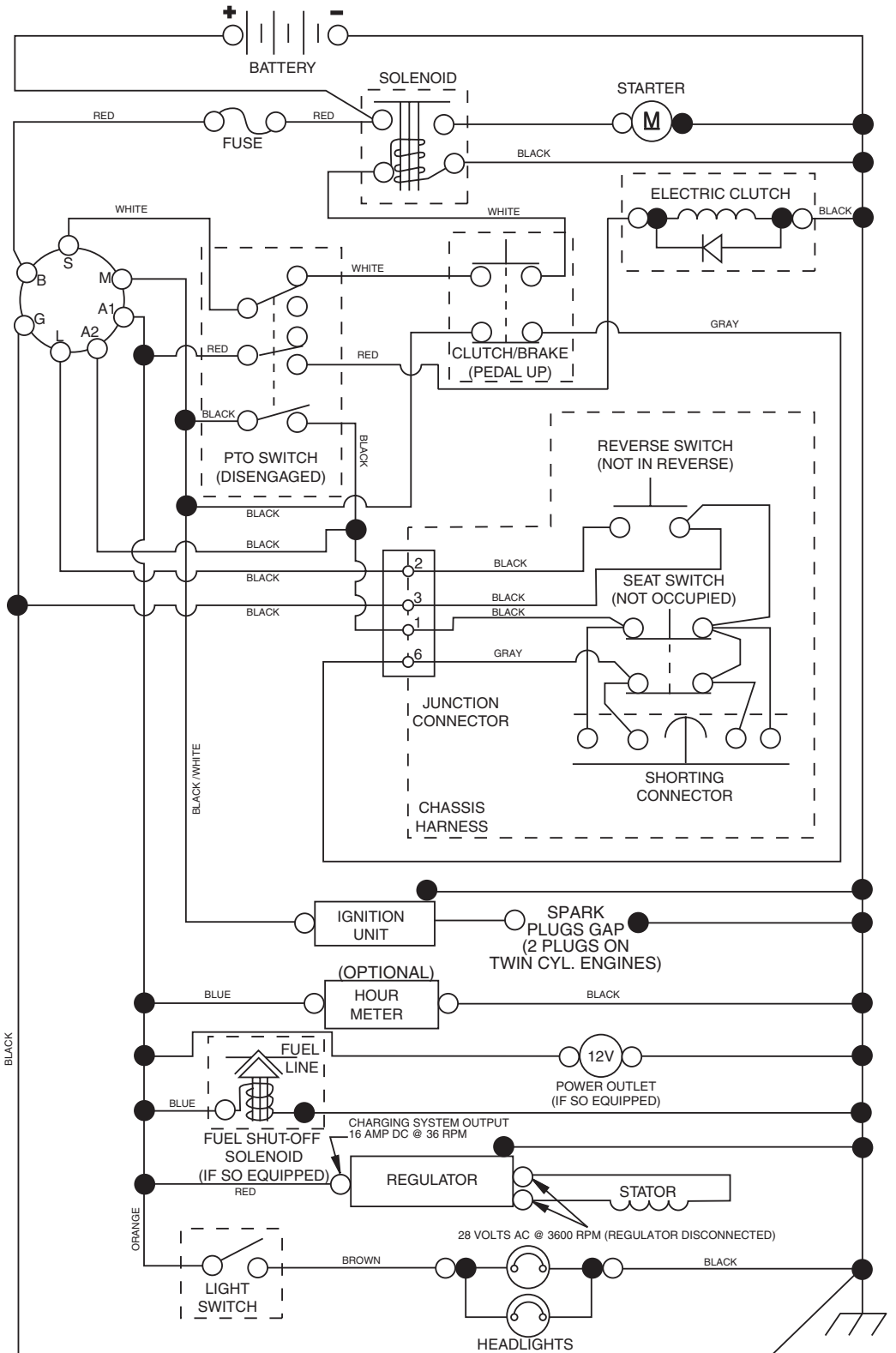

IGNITION SWITCH

POSITION	CIRCUIT	"MAKE"
OFF	M+G+A1	
RUN/OVERRIDE	B+A1	
RUN	B+A1	L+A2
START	B + S + A1	

02929

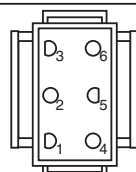

CHASSIS HARNESS CONNECTOR (MATING SIDE)

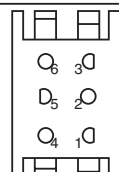

DASH HARNESS CONNECTOR (MATING SIDE)

WIRING INSULATED CLIPS
NOTE: IF WIRING INSULATED CLIPS WERE REMOVED FOR SERVICING OF UNIT, THEY SHOULD BE REPLACED TO PROPERLY SECURE YOUR WIRING.

●
NON-REMOVABLE CONNECTIONS

○
REMOVABLE CONNECTIONS

**TRACTOR - MODEL NO. GTH26K54 (96043003100), PRODUCT NO. 960 43 00-31
ELECTRICAL**

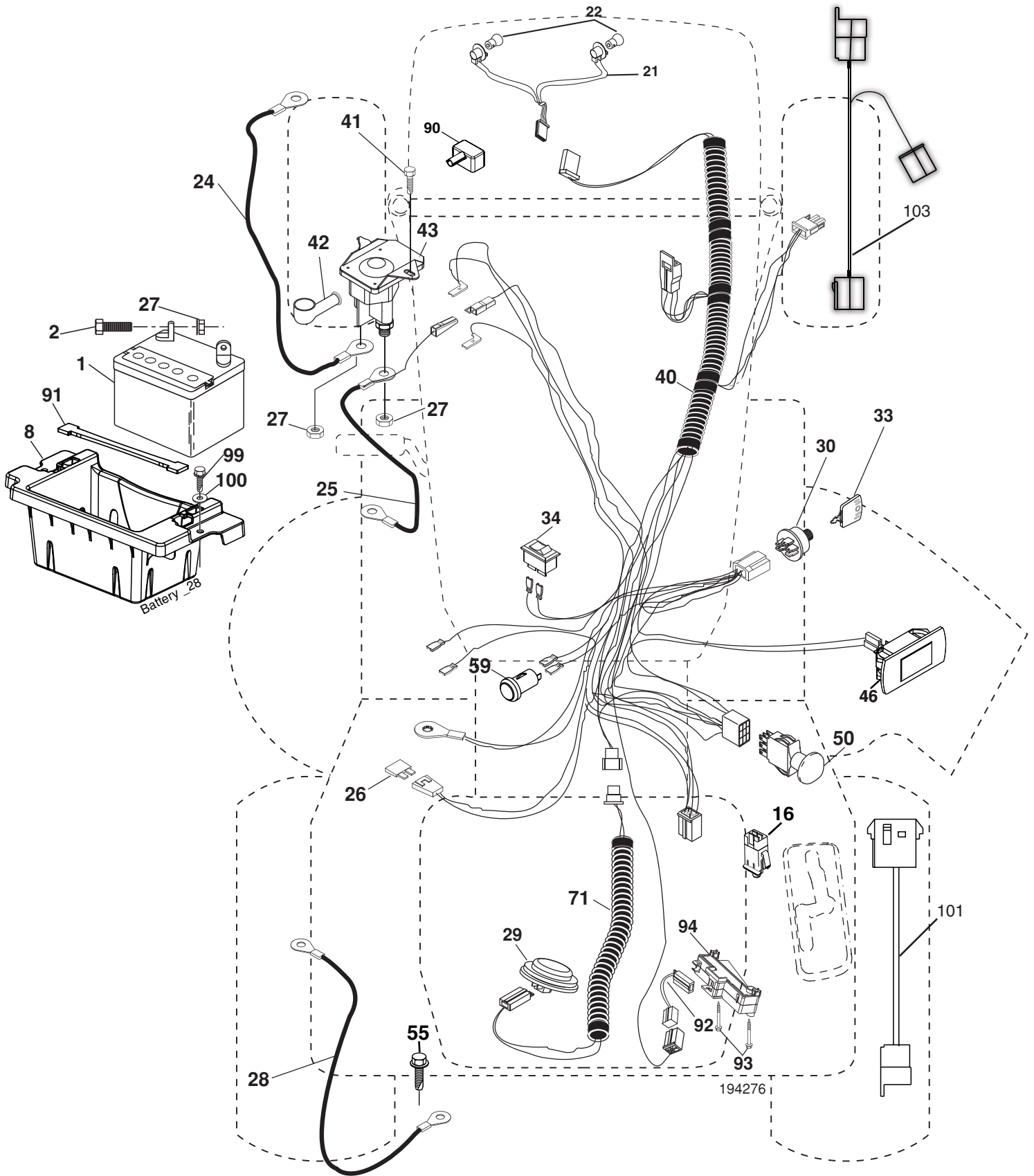

**TRACTOR - MODEL NO. GTH26K54 (96043003100), PRODUCT NO. 960 43 00-31
ELECTRICAL**

KEY NO.	PART NO.	DESCRIPTION
1	532 14 49-27	Battery
2	874 76 04-12	Bolt Hex Hd 1/4-20 unc x 3/4
8	532 18 64-91	Battery Box
16	532 17 61-38	Switch Interlock
21	532 18 37-59	Harness Socket Light
22	532 00 41-52	Bulb, Light # 1156
24	532 40 02-53	Cable Battery
25	532 19 88-93	Cable Starter
26	532 17 51-58	Fuse
27	873 51 04-00	Nut Keps Hex 1/4-20 unc
28	532 14 54-91	Cable Ground 21" Blk 6 Ga.
29	532 40 15-45	Switch Seat
30	532 19 33-50	Switch Ign
33	532 14 04-01	Key Ign Molded Generic
34	532 11 07-12	Switch Light/Reset
40	532 40 11-04	Harness Ign
41	817 72 04-08	Screw Thd Cut 1/4-20 x 1/2
42	532 13 15-63	Cover Terminal Red
43	532 19 25-07	Solenoid
46	532 40 17-63	Gauge Hourmeter
50	532 17 46-51	Switch PTO
55	817 49 05-12	Screw Thdrol 5/16-18 x 3/4
59	532 40 03-03	Outlet 12-Volt
71	532 19 42-76	Harness Ign. Dash
90	532 40 07-24	Cover Terminal Battery
91	532 19 02-70	Strap Battery
92	532 19 66-15	Harness Pigtail
93	532 19 25-40	Screw Plastite 10-14 x 2.0
94	532 19 18-34	Module Reverse ROS
99	817 67 04-12	Screw Hexwsh Thdrol 1/4-20 x 3/4
100	819 09 14-16	Washer 9/32 x 7/8 x 16 Ga.
101	532 19 83-17	Pigtail MATNLK Harness
103	532 40 79-62	Harness Pigtail 12V outlet

NOTE: All component dimensions given in U.S. inches
1 inch = 25.4 mm

TRACTOR - MODEL NO. GTH26K54 (96043003100), PRODUCT NO. 960 43 00-31 CHASSIS

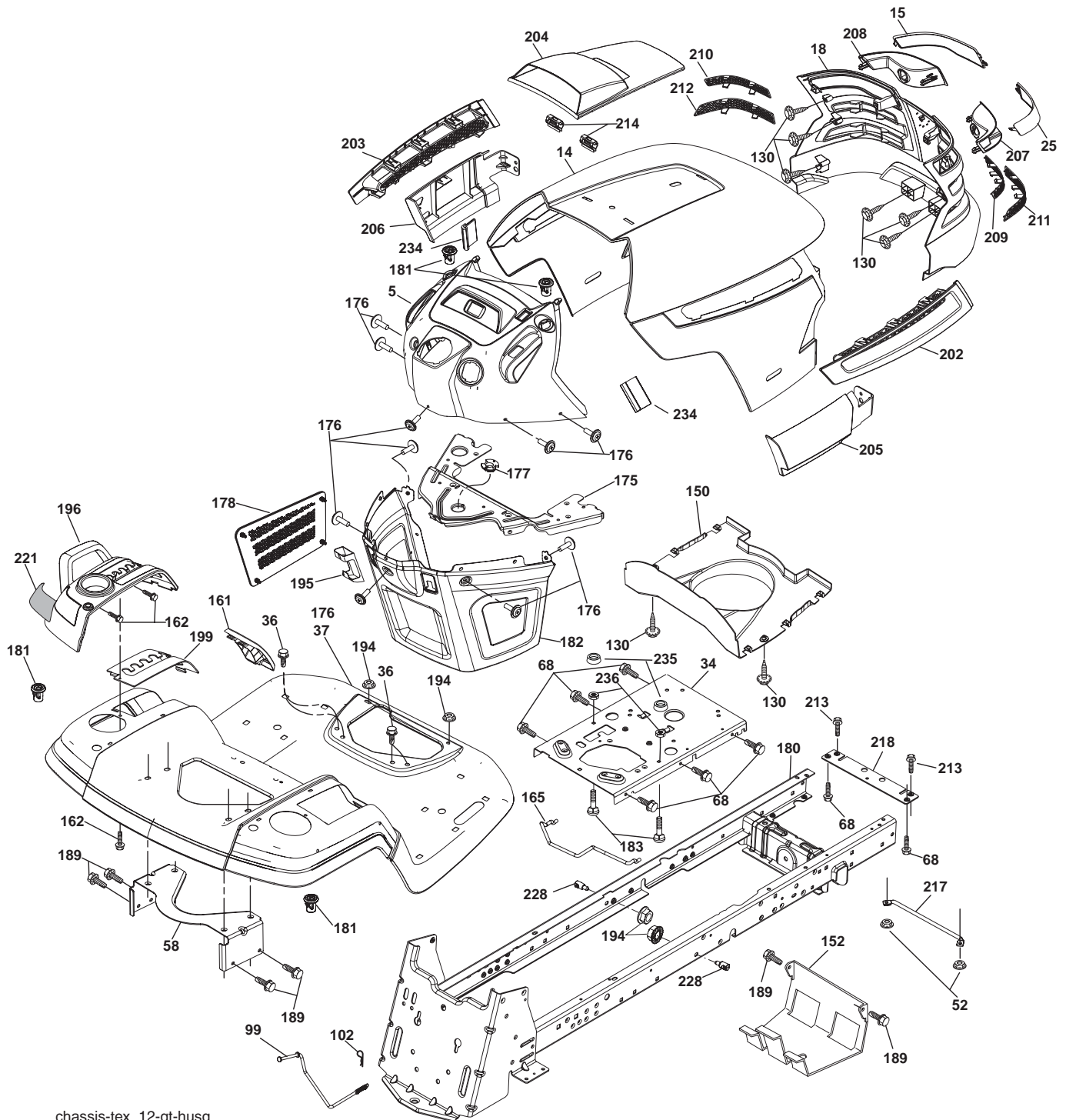

chassis-tex_12-gt-husq

**TRACTOR - MODEL NO. GTH26K54 (96043003100), PRODUCT NO. 960 43 00-31
CHASSIS**

KEY NO.	PART NO.	DESCRIPTION
5	532 40 87-01	Dash
14	532 41 10-46	Hood
15	532 19 89-07	Lens LH
18	532 40 48-21	Grille
25	532 19 89-06	Lens RH
34	532 19 61-25	Plate Engine
36	817 06 05-12	Screw 5/16-18 x 3/4
37	532 40 18-25	Fender
52	873 68 05-00	Nut Crown Lock 5/16-18
58	532 19 43-14	Bracket Fender
68	817 49 05-08	Screw 5/16-18 x 1/2
99	532 19 72-73	Rod Bypass Asm.
130	532 19 16-11	Screw 10 x 3/4 Single Lead Hex
150	532 19 85-12	Duct Heat Hood
152	532 19 95-35	Shield Browning/Debris
161	532 40 17-70	Console Fuel Window
162	532 14 24-32	Screw Hex Wsh Hi-Lo 1/4 x 1/2
165	532 19 68-26	Bracket Support Tank
175	532 19 63-04	Crossmember
176	532 40 07-76	Screw 10-24 x 5/8 Wshd Qdrx
177	532 19 52-27	Bushing Steering
178	532 19 97-82	Cargo Asm. Net
180	532 19 54-77	Chassis
181	532 40 30-25	Bushing Mtg. Fender Crgo.
182	532 19 47-87	Dash Lower
184	532 40 61-29	Spacer Fender
185	874 78 05-20	Bolt Fin Hex 5/16-18 unc x 1-1/4

KEY NO.	PART NO.	DESCRIPTION
189	817 00 05-12	Screw 5/16-18 x 3/4
194	873 90 05-00	Nut Lock Hex Flange 5/16-18
195	532 40 35-71	Plug Cruise/Phone
196	532 40 02-99	Console Asm. Deck Lift
199	532 19 82-59	Plate Deck Lift
202	532 40 30-48	Vent Side Hood RH
203	532 40 30-76	Vent Side Hood LH
204	532 19 89-04	Vent Asm Hood Top
205	532 40 17-09	Skirt Hood Side RH
206	532 40 17-11	Skirt Hood Side LH
207	532 19 71-98	Bezel RH
208	532 19 71-99	Bezel LH
209	532 19 91-30	Insert Hex Top RH
210	532 19 91-31	Insert Hex Top LH
211	532 19 91-32	Insert Hex Bottom RH
212	532 19 91-33	Insert Hex Bottom LH
213	874 76 05-12	Bolt Hex Hd 5/16-18 unc x 3/4
214	532 19 91-45	Clip Retainer
217	532 15 65-24	Rod Pivot
218	532 19 63-95	Hood Stop
221	532 19 89-09	Reflector LH
228	532 19 51-61	Stud Fastener
234	532 40 47-42	Bumper Hood
236	873 93 05-00	Nut Center Lock 5/16-18 UNC

NOTE: All component dimensions given in U.S. inches
1 inch = 25.4 mm

TRACTOR - MODEL NO. GTH26K54 (96043003100), PRODUCT NO. 960 43 00-31 DRIVE

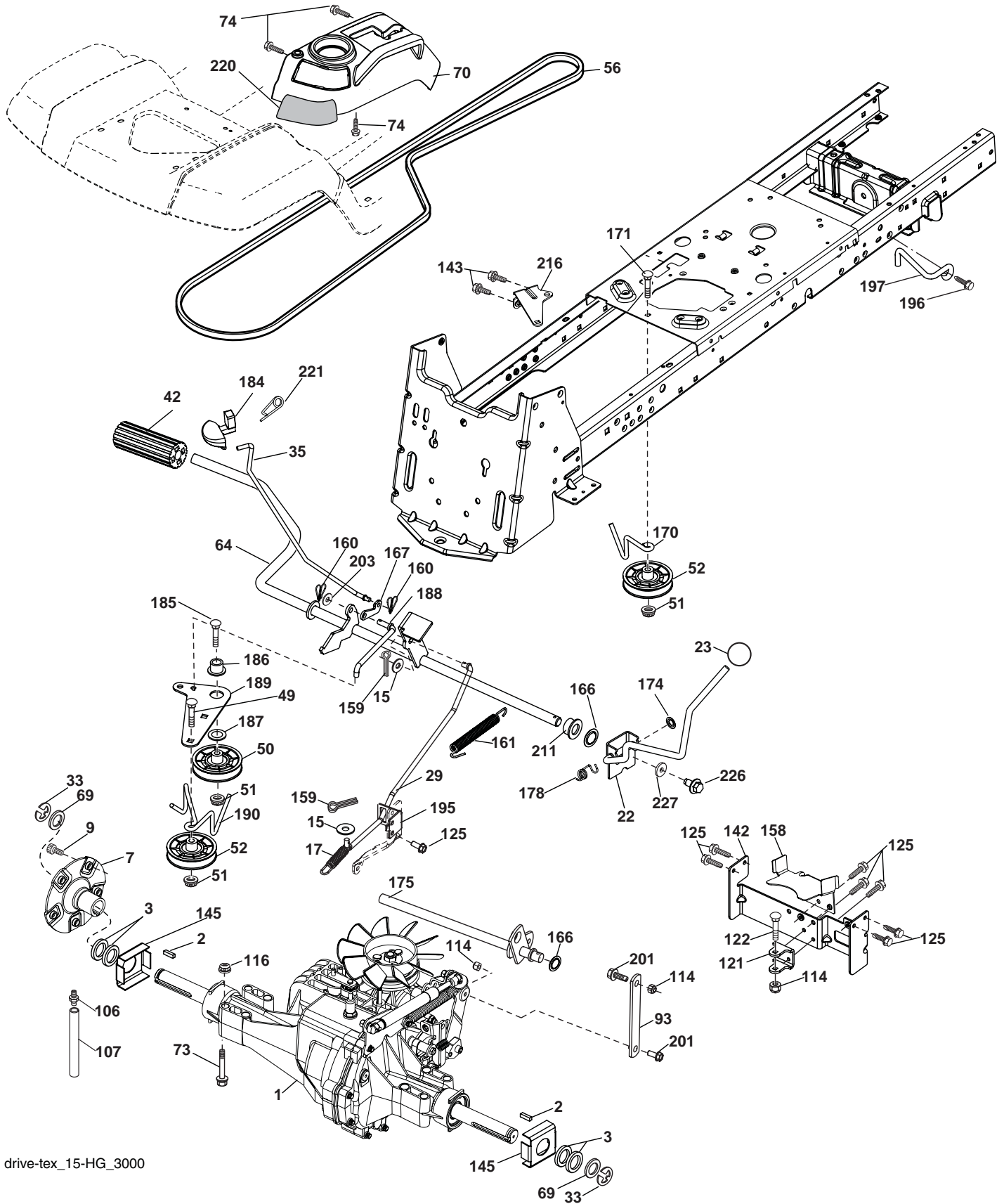

drive-tex_15-HG_3000

**TRACTOR - MODEL NO. GTH26K54 (96043003100), PRODUCT NO. 960 43 00-31
DRIVE**

KEY NO.	PART NO.	DESCRIPTION
1	-----	Transaxle, Hydro 344-3000 (Order Parts from Transaxle Manufacturer)
2	532 18 62-11	Key 1/4 x 2.5
3	532 00 75-63	Washer
7	532 19 98-37	Hub Asm. Wheel
9	532 14 00-80	Bolt Hub Wheel
15	819 13 13-16	Washer 13/32 x 13/16 x 16 Ga.
17	532 19 72-96	Spring, Brake
22	532 40 05-04	Shifter Rod
23	532 14 08-45	Knob
29	532 19 72-69	Rod, Brake
33	812 00 00-53	Ring E
35	532 19 95-91	Rod, Brake, Park
42	532 12 48-72	Cover, Foot Pedal
49	872 11 06-14	Bolt
50	532 19 43-27	Pulley Idler Flat
51	873 90 06-00	Lock Nut 3/8-16
52	532 19 43-26	Idler V-Groove 910" Offset
56	532 16 58-13	V-Belt, Drive
64	532 19 62-00	Shaft Asm. Pedal Brake Control
69	532 12 38-00	Washer 11/32 x 1-5/8 x 16 Ga.
70	532 40 02-98	Control Asm.
73	874 49 05-48	Bolt Hex Flghd 5/16-18 x 3.00
74	532 14 24-32	Screw 1/4 x 1/2
93	532 19 62-13	Link Shift
106	532 14 29-17	Cap Asm. Vent
107	532 41 04-81	Tube Vent
114	873 80 05-00	Nut Lock Hex w/Insert 5/16-18 unc
116	873 90 05-00	Nut Lock Hex Flange 5/16-18
121	532 17 56-11	Bracket Strap Torque
122	872 01 05-20	Bolt 5/16 - 18 x 2.50
125	817 00 05-12	Screw 5/16-18 x 3/4
142	532 40 44-83	Strap Torque

KEY NO.	PART NO.	DESCRIPTION
143	817 49 05-08	Screw Thdrol 5/16-18 x 1/2
145	532 16 31-68	Washer Axle flange
158	532 19 43-51	Keeper Belt
159	876 02 04-12	Pin Cotter 1/8 x 3/4
160	532 16 94-84	Retainer Clip
161	532 19 54-03	Spring, Return, Clutch
166	532 19 72-90	Nut Push .625
167	532 40 52-57	Latch Brake Parking
170	532 19 43-22	Keeper Belt Centerspan
171	872 11 06-16	Bolt
174	532 19 72-89	Nut Push
175	532 19 62-04	Shaft Asm Shift
178	532 19 74-56	Spring Shift
184	532 40 31-18	Handle Parking Brake
185	872 11 06-20	Bolt Rdhd Sqnk 3/8-16 x 2-1/2
186	532 19 43-21	Spacer Retainer
187	819 13 32-10	Washer
188	532 19 43-23	Link Clutch Ground Drive
189	532 19 43-17	Bellcrank Ground Drive
190	532 19 43-18	Keeper Bellcrank Ground Dr.
195	532 40 51-13	Bracket Rod Brake
196	817 00 06-16	Screw 3/8-16 x 1
197	532 19 97-69	Bracket Clutch Anti-Rotation
200	873 93 05-00	Nut Center Lock 5/16-18
201	532 16 96-12	Bolt Shoulder 5/16-18 unc
203	819 11 11-16	Washer 11/32 x 11/16 x 16 Ga.
211	532 19 62-12	Bushing
216	532 19 61-31	Bracket Pulley Idler
220	532 19 89-08	Reflector RH
221	532 40 31-87	Retainer Spring Clip Handle
226	874 78 07-16	Bolt Fin Hex 7/16 - 14 x 1 GR5
227	532 40 52-96	Washer Serrated

NOTE: All component dimensions given in U.S. inches
1 inch = 25.4 mm

TRACTOR - MODEL NO. GTH26K54 (96043003100), PRODUCT NO. 960 43 00-31

STEERING ASSEMBLY

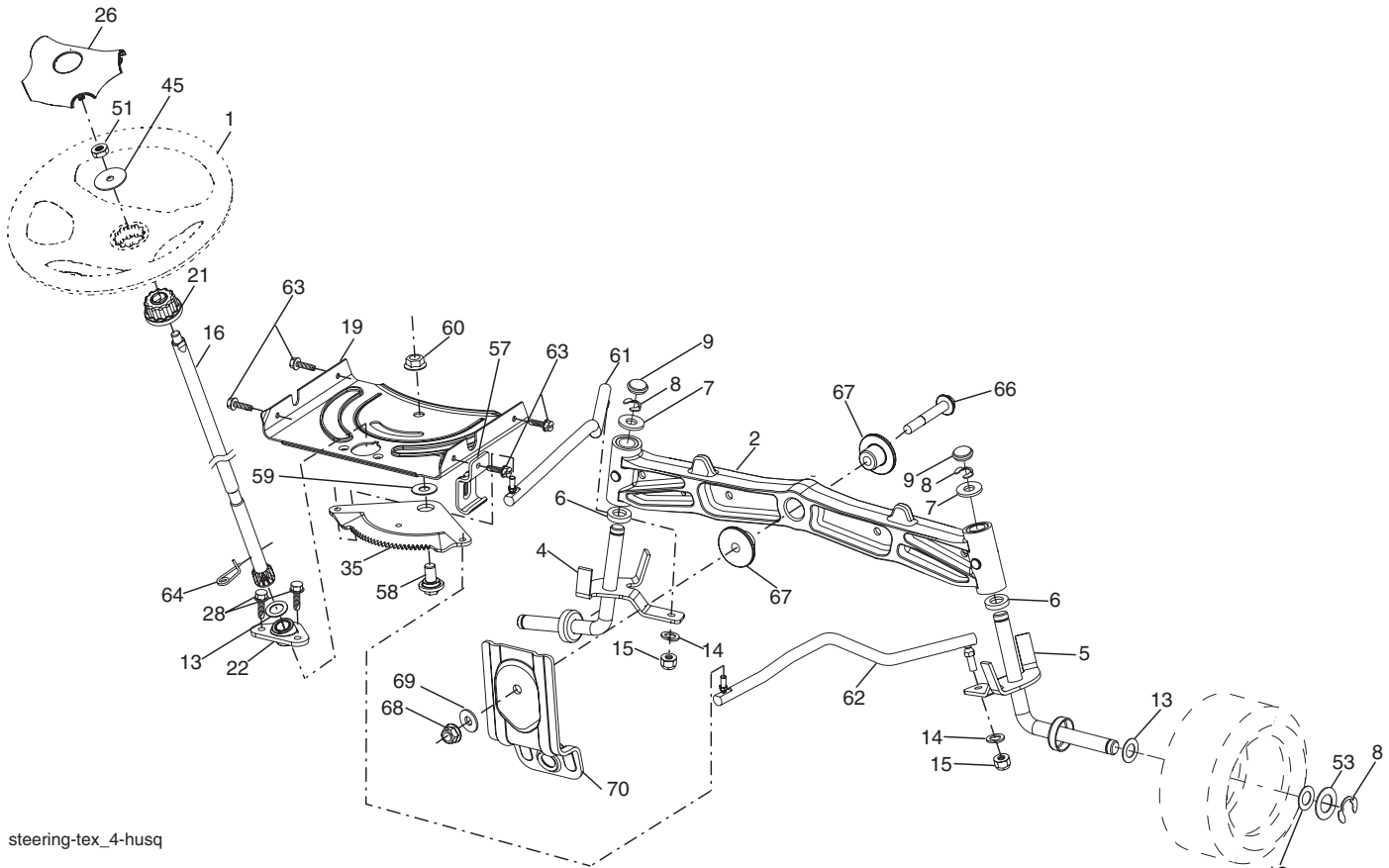

steering-tex_4-husq

KEY NO.	PART NO.	DESCRIPTION
1	532 19 39-43	Wheel, Steering
2	532 19 59-68	Axle Asm., Front
4	532 40 30-89	Spindle Asm. LH
5	532 40 30-90	Spindle Asm. RH
6	532 12 49-31	Bearing, Race Thrust Harden
7	532 12 17-48	Washer 25/32 x 1-5/8 x 16 Ga.
8	812 00 00-29	Ring, Klip #T5304-75
9	532 12 12-32	Cap, Spindle
13	532 12 17-49	Washer 25/32 x 1-1/4 x 16 Ga.
14	810 04 06-00	Washer, Lock Hvy Hlcl Spr 3/8
15	873 54 06-00	Nut, Crown Lock 3/8-24 unf
16	532 19 47-46	Shaft Steering
19	532 19 47-29	Plate Steering
21	532 18 67-37	Adapter, Wheel Steering
22	532 19 48-45	Bushing, Strg. Blk
26	532 19 36-52	Insert, Wheel Steering
28	817 00 06-12	Screw 3/8-16 x 3/4
35	532 19 47-32	Gear, Sector Plate
45	819 18 38-12	Washer 9/16 x 2-3/8 x 12 Ga.

KEY NO.	PART NO.	DESCRIPTION
51	873 94 08-00	Nut Hex Jam Toplock 1/2-20 unf
53	532 18 89-67	Washer Hardened
57	532 19 72-46	Bracket Upstop
58	532 19 47-47	Bolt Shoulder Sector Pivot CFM
59	532 19 47-48	Washer Thrust Sector Steering
60	873 97 10-00	Nut Flange Lock 5/8-11
61	532 19 47-40	Draglink LH
62	532 19 47-41	Draglink, RH
63	817 00 05-12	Screw 5/16-18 x 3/4
64	532 19 98-49	Retainer Clip Spring Steering
66	871 02 07-48	Bolt Hex Fghd 7/16-14 x 3 Serr
67	532 19 47-37	Bushing PM Front Axle
68	873 90 07-00	Nut Lock Flange 7/16-14 Gr. 5
69	532 19 91-62	Washer 1.5 x .505 x .118
70	532 19 61-97	Bracket Deck Susp. Front

NOTE: All component dimensions given in U.S. inches
1 inch = 25.4 mm

TRACTOR - MODEL NO. GTH26K54 (96043003100), PRODUCT NO. 960 43 00-31 ENGINE

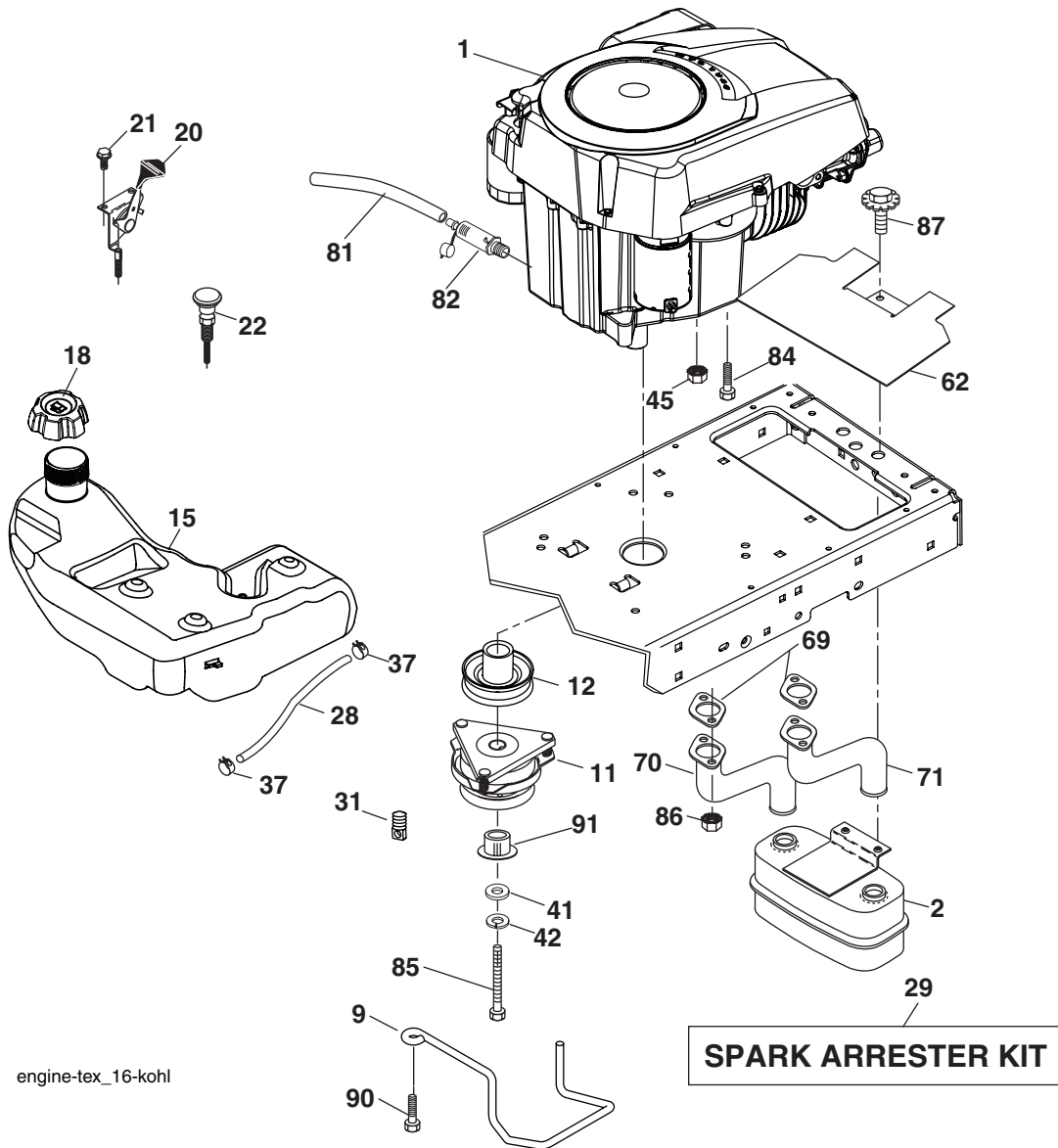

engine-tex_16-kohl

KEY NO.	PART NO.	DESCRIPTION
1	-----	Engine Kohler Model No. SV735
2	532 14 97-23	Muffler
9	532 19 43-20	Keeper Belt Engine
11	532 17 93-35	Clutch Electric
12	532 19 43-43	Pulley Engine
15	532 19 34-99	Tank Fuel 4.0
18	532 19 42-67	Cap Asm
20	532 18 29-37	Control Throttle
21	532 19 16-11	Screw 10 x 3/4 Single Lead Hex
22	532 19 15-96	Control Choke
28	532 40 11-35	Fuel Line
29	532 13 71-80	Spark Arrester Kit
31	532 14 50-06	Clip Push-In
37	532 12 34-87	Clamp Hose
41	532 12 61-97	Washer 1-1/2 OD x 15/32 ID x .250
42	810 04 07-00	Washer Lock 7/16
45	873 51 04-00	Nut Keps Hex 1/4-20 unc
62	532 14 66-29	Shield Heat Muffler
69	532 18 68-54	Gasket

KEY NO.	PART NO.	DESCRIPTION
70	532 14 66-99	Tube Exhaust LH
71	532 14 67-00	Tube Exhaust RH
81	532 14 84-56	Tube Drain Oil Easy
82	532 18 16-54	Plug Drain Oil
84	817 12 06-16	Screw 3/8-16 x 1
85	532 17 99-53	Bolt Hex 7/16-20 x 3.75 Gr. 5
86	532 18 43-62	Nut Hex M8-1.25
87	532 19 82-39	Bolt 5/16-18 unc x 1 w/Sems
90	817 00 06-16	Screw 3/8-16 x 1
91	532 18 74-95	Bushing

NOTE: All component dimensions given in U.S. inches
1 inch = 25.4 mm

For engine service and replacement parts, call the toll free number for your engine manufacturer listed below:

Briggs & Stratton	1-800-233-3723
Kohler Co.	1-800-544-2444
Tecumseh Products	1-800-558-5402
Honda Engines	1-800-426-7701
Kawasaki	1-949-460-5688

**TRACTOR - MODEL NO. GTH26K54 (96043003100), PRODUCT NO. 960 43 00-31
SEAT ASSEMBLY**

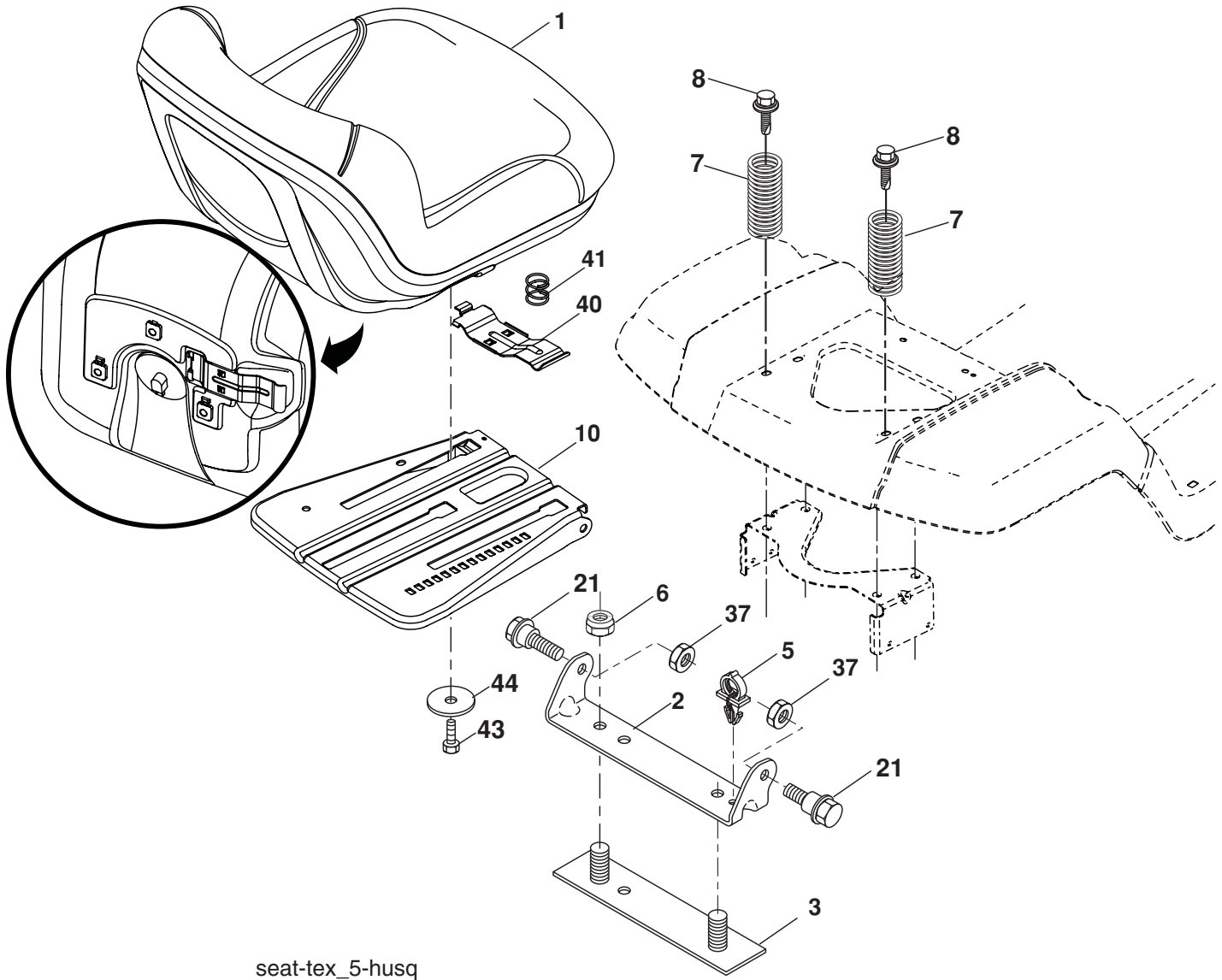

seat-tex_5-husq

KEY NO.	PART NO.	DESCRIPTION
1	532 40 66-21	Seat
2	532 18 01-66	Bracket Pivot Fender
3	532 14 06-75	Strap, Asm Fender
5	532 14 50-06	Clip, Push In, Hinged
6	873 80 06-00	Nut, Lock W/Ins. 3/8-16 unc
7	532 12 41-81	Spring, Seat Cprsn
8	532 17 18-77	Bolt 5/16-18 uncx 3/4 w/Sems
10	532 19 69-77	Pan, Seat
21	532 17 18-52	Bolt, Shoulder 5/16-18

KEY NO.	PART NO.	DESCRIPTION
37	873 80 05-00	Nut, Lock 5/16-18 unc
40	532 19 76-61	Handle Slide Seat
41	532 19 82-00	Spring Latch Seat
43	874 76 06-12	Bolt Fin Hex 3/8-16 unc x 3/4
44	819 13 38-12	Washer 13/32 x 2-3/8 x 12 Ga.

NOTE: All component dimensions given in U.S. inches
1 inch = 25.4 mm

**TRACTOR - MODEL NO. GTH26K54 (96043003100), PRODUCT NO. 960 43 00-31
DECALS**

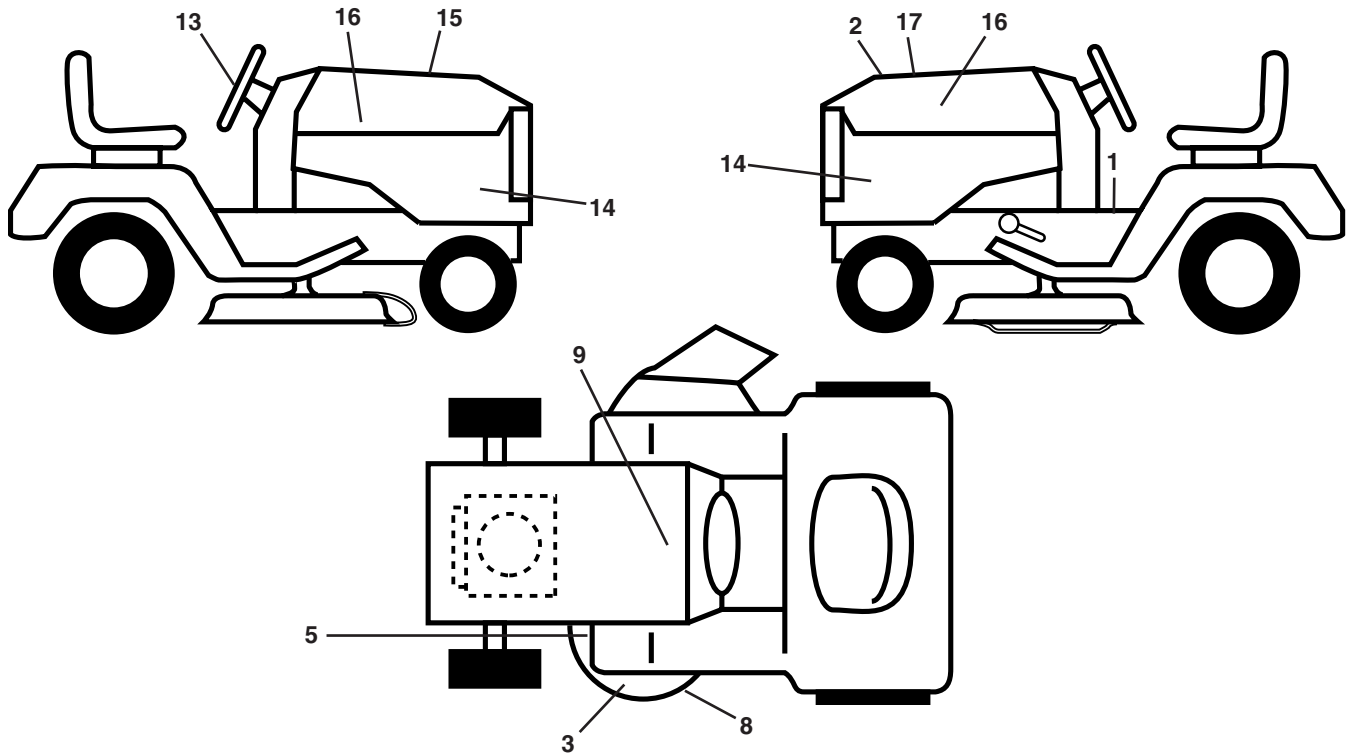

KEY NO.	PART NO.	DESCRIPTION
1	532 19 91-14	Decal, Operator's
2	532 40 21-28	Decal, Hood Insert
3	532 17 05-63	Decal, Warning
5	532 17 85-02	Decal, Caution
8	532 19 87-85	Decal, Mower Sch.
9	532 14 50-05	Decal, Battery Dnge/Poi
13	532 40 44-84	Decal, Steeraing Whl
14	532 40 83-63	Decal, Panel Side

KEY NO.	PART NO.	DESCRIPTION
15	532 18 09-41	Decal, Cust. Resp.
16	532 40 28-32	Decal, Hood Logo
17	532 40 84-67	Decal, Replacement
--	532 16 69-60	Decal, Bypass
--	532 40 17-71	Pad, Footrest, LH
--	532 40 17-70	Pad, Footrest, RH
--	532 40 83-77	Manual, Owner's (Eng)
--	532 40 83-78	Manual, Owner's (Fr)

WHEELS AND TIRES

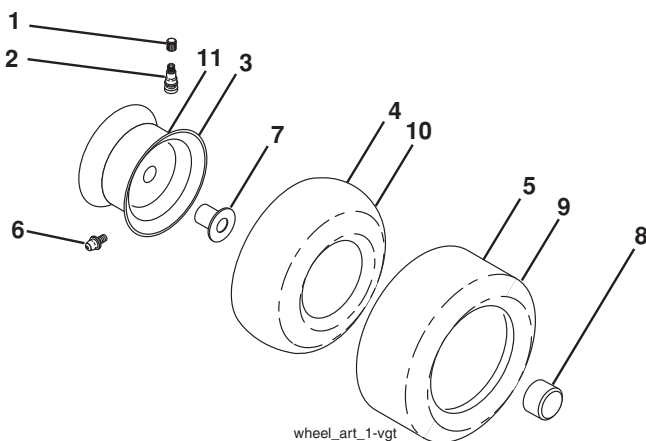

KEY NO.	PART NO.	DESCRIPTION
1	532 05 91-92	Cap, Valve, Tire
2	532 06 51-39	Stem, Valve
3	532 14 45-09	Rim Assembly, Front
4	532 05 99-04	Tube, Front (Service Item Only)
5	532 10 62-30	Tire, Front
6	532 12 49-57	Fitting, Grease (Front Wheel Only)
7	532 12 49-59	Bearing, Flange (Front Wheel Only)
8	532 17 50-39	Cap, Axle (Front Wheel Only)
9	532 10 55-88	Tire, Rear
10	532 12 49-26	Tube, Rear (Service Item Only)
11	532 14 45-10	Rim Assembly, Rear
--	532 14 43-34	Sealant, Tire (10 oz. Tube)

NOTE: All component dimensions given in U.S. inches
1 inch = 25.4 mm

**TRACTOR - MODEL NO. GTH26K54 (96043003100), PRODUCT NO. 960 43 00-31
MOWER DECK**

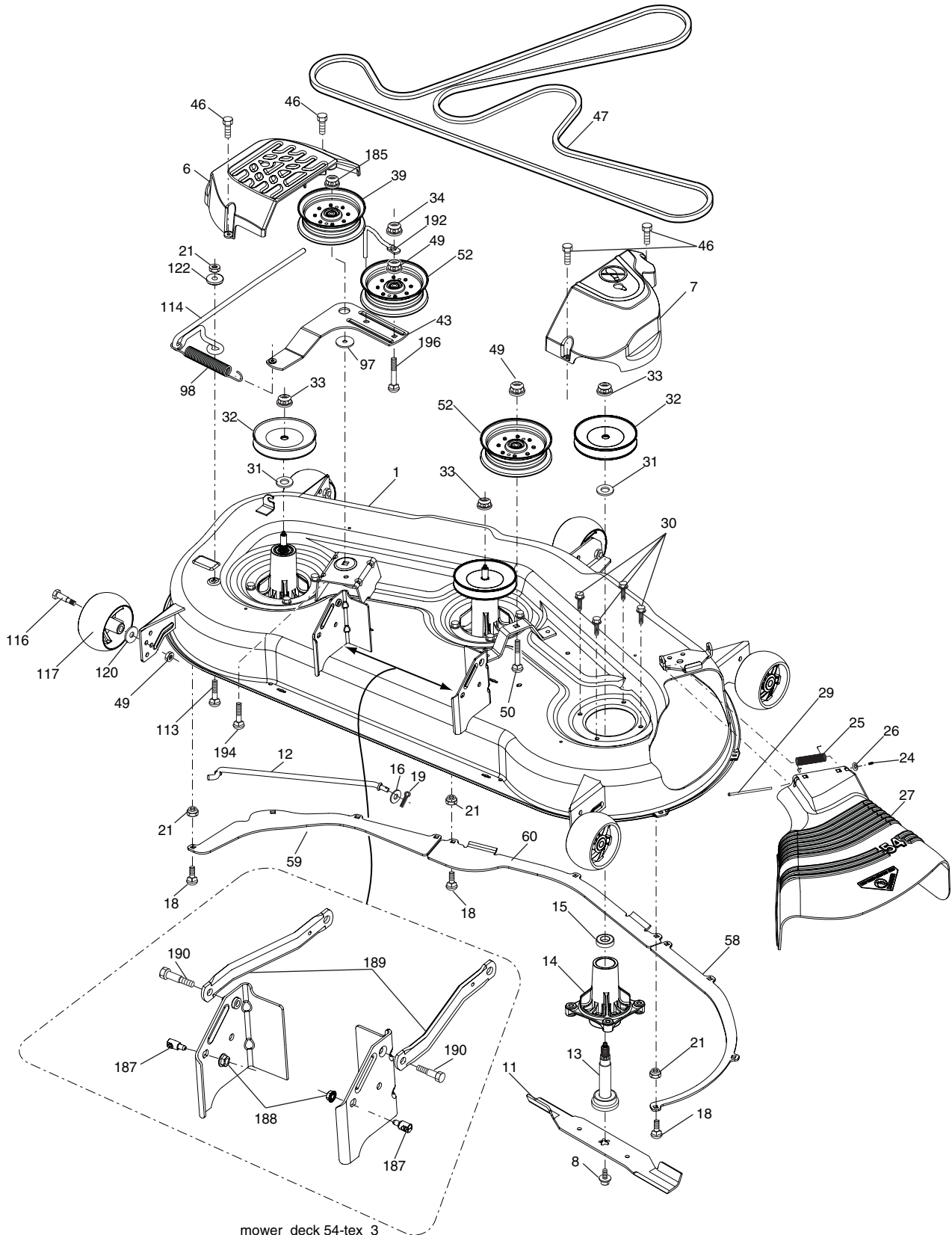

**TRACTOR - MODEL NO. GTH26K54 (96043003100), PRODUCT NO. 960 43 00-31
MOWER DECK**

KEY NO.	PART NO.	DESCRIPTION
1	532 40 31-25	Deck Weldment Mower
6	532 19 60-66	Cover Mandrel LH
7	532 19 71-81	Cover Mandrel RH
8	532 17 43-65	Bolt 7/16 Asm. Blade
11	532 18 72-54	Blade High Lift
12	532 40 03-37	Bar Anti-Sway
13	532 18 72-91	Shaft Asm. w/Lower Bearing
14	532 18 72-81	Housing, Mandrel
15	532 11 04-85	Bearing, Ball, Mandrel
16	819 13 13-12	Washer 3/8
18	872 14 05-05	Bolt RdHd 5/16-18 unc x 5/8
19	532 19 42-08	Pin Cotter 5/16 Bowtie
21	873 68 05-00	Nut, Crownlock 5/16-18 unc
24	532 10 53-04	Cap Sleeve
25	532 17 81-02	Spring, Torsion
26	532 11 04-52	Nut, Push
27	532 18 89-38	Deflector Shield
29	532 13 14-91	Rod, Hinge
30	532 17 39-84	Screw, Thdroll Washer Head
31	532 18 76-90	Washer, Spacer Mower Vented
32	532 17 34-36	Pulley, Mandrel
33	532 40 02-34	Nut, Flg. Top Lock
34	873 68 06-00	Nut Crownlock 3/8-46 UNC
39	532 19 61-04	Pulley, Idler, Stationary LH
43	532 19 60-65	Arm, Idler
46	532 13 77-29	Screw, Thdroll. 1/4-20 x 5/8
47	532 19 61-03	Belt Deck Drive
49	873 90 06-00	Nut, Lock Flg. 3/8-16 unc
50	872 11 06-16	Bolt Carriage 3/8-16 x 2 Gr. 5

KEY NO.	PART NO.	DESCRIPTION
52	532 19 61-06	Pulley Idler
58	532 18 73-42	Baffle Right
59	532 18 73-44	Baffle Left
60	532 18 76-07	Baffle Center
97	532 17 85-15	Washer Hardened
98	532 19 61-05	Spring Drive
113	872 11 05-08	Bolt Rdhd Sqnk 5/16-18 x 3/4
114	532 18 75-56	Rod Tension Relief
116	532 19 34-06	Bolt, Shoulder
117	532 17 48-73	Gauge Wheel
120	819 13 20-12	Washer 13/32 x 1-1/4 x 12 Ga.
122	532 18 75-57	Bushing Tension Relief
185	873 90 07-00	Nut Lock Flange 7/16-14 Gr. 5
187	532 19 51-61	Stud Fastener w/"D" Anti-Rotation
188	873 90 05-00	Nut Lock Hex Flange
189	532 19 51-85	Arm Susp. Mower Rear
190	532 19 65-39	Bolt Shoulder
192	532 19 84-68	Keeper Belt Idler
194	872 14 07-16	Bolt Carr Sqnk 7/16-24 x 2
196	872 14 06-20	Bolt RDHD SQNK 3/8-16 x 2-1/2 Gr.5
--	532 18 72-92	Mandrel Asm. Service (Includes Key Nos. 13-15 and 33)
--	532 19 93-00	Replacement Mower, Complete

NOTE: All component dimensions given in U.S. inches
1 inch = 25.4 mm

**TRACTOR - MODEL NO. GTH26K54 (96043003100), PRODUCT NO. 960 43 00-31
MOWER LIFT**

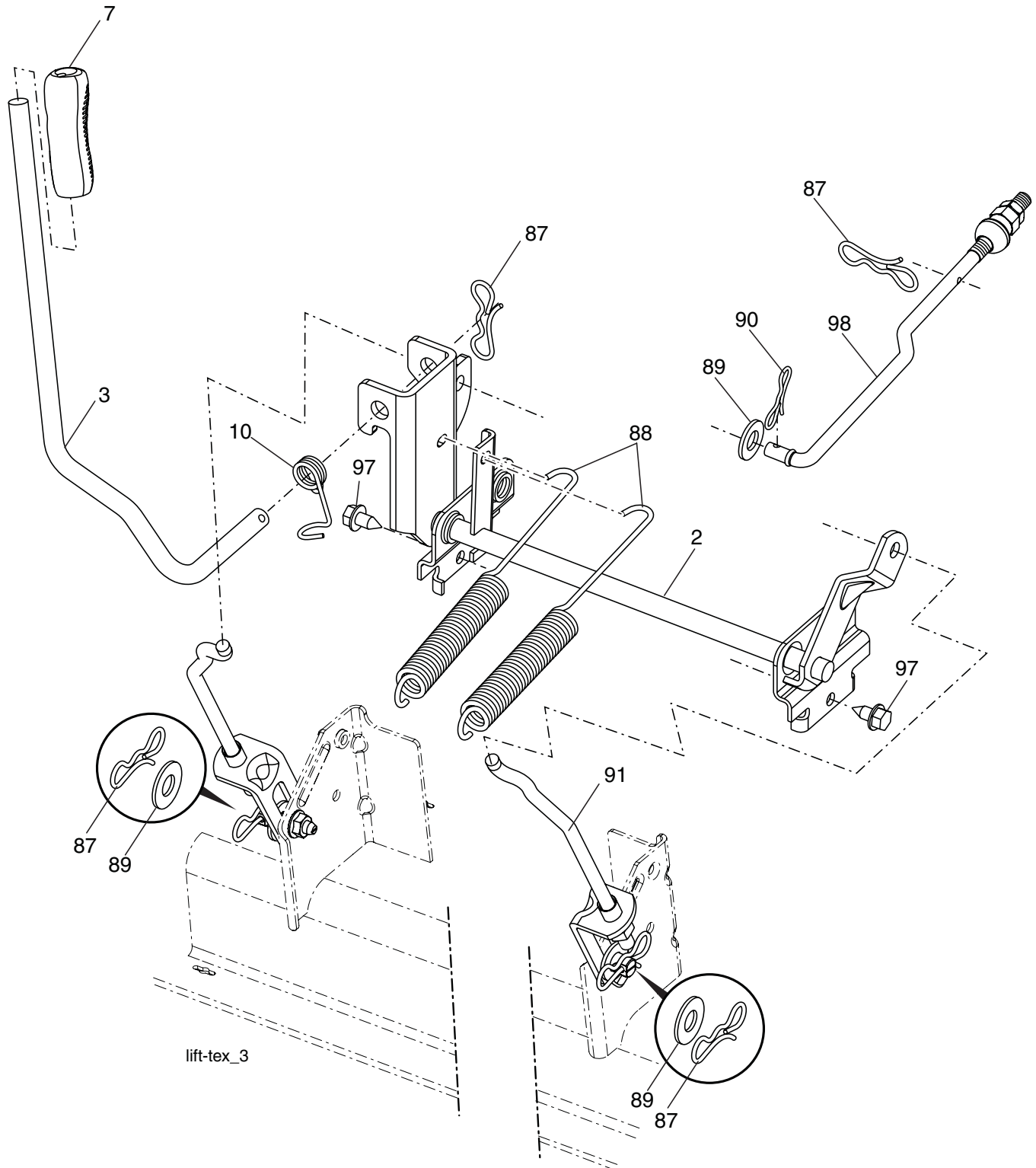

KEY NO.	PART NO.	DESCRIPTION
2	532 19 52-23	Shaft Asm., Lift
3	532 19 52-30	Lever Asm., Lift Rh
7	532 19 64-92	Grip, Lever
10	532 19 63-14	Spring Torsion
87	532 19 42-09	Pin Cotter 7/16 Bow Tie Lock
88	532 19 53-04	Spring Lift Assist
89	819 19 19-12	Washer Clear Zinc

KEY NO.	PART NO.	DESCRIPTION
90	532 19 42-08	Pin Cotter 5/16 Bow Tie Lock
91	532 40 34-07	Link Lift Susp Mower Rear
97	817 06 06-12	Screw 3/8-16 x .75 Smgml Tap/R.Z
98	532 19 52-64	Link Lift Susp. Front Mower

NOTE: All component dimensions given in U.S. inches
1 inch = 25.4 mm