

YTH20K46

Parts Manual

TRACTOR -- MODEL NUMBER YTH20K46 (96043003300), PRODUCT NO. 960 43 00-33 SCHEMATIC

SCH10

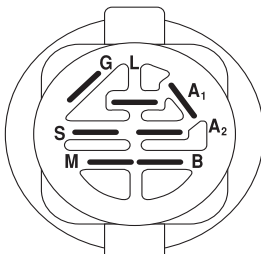
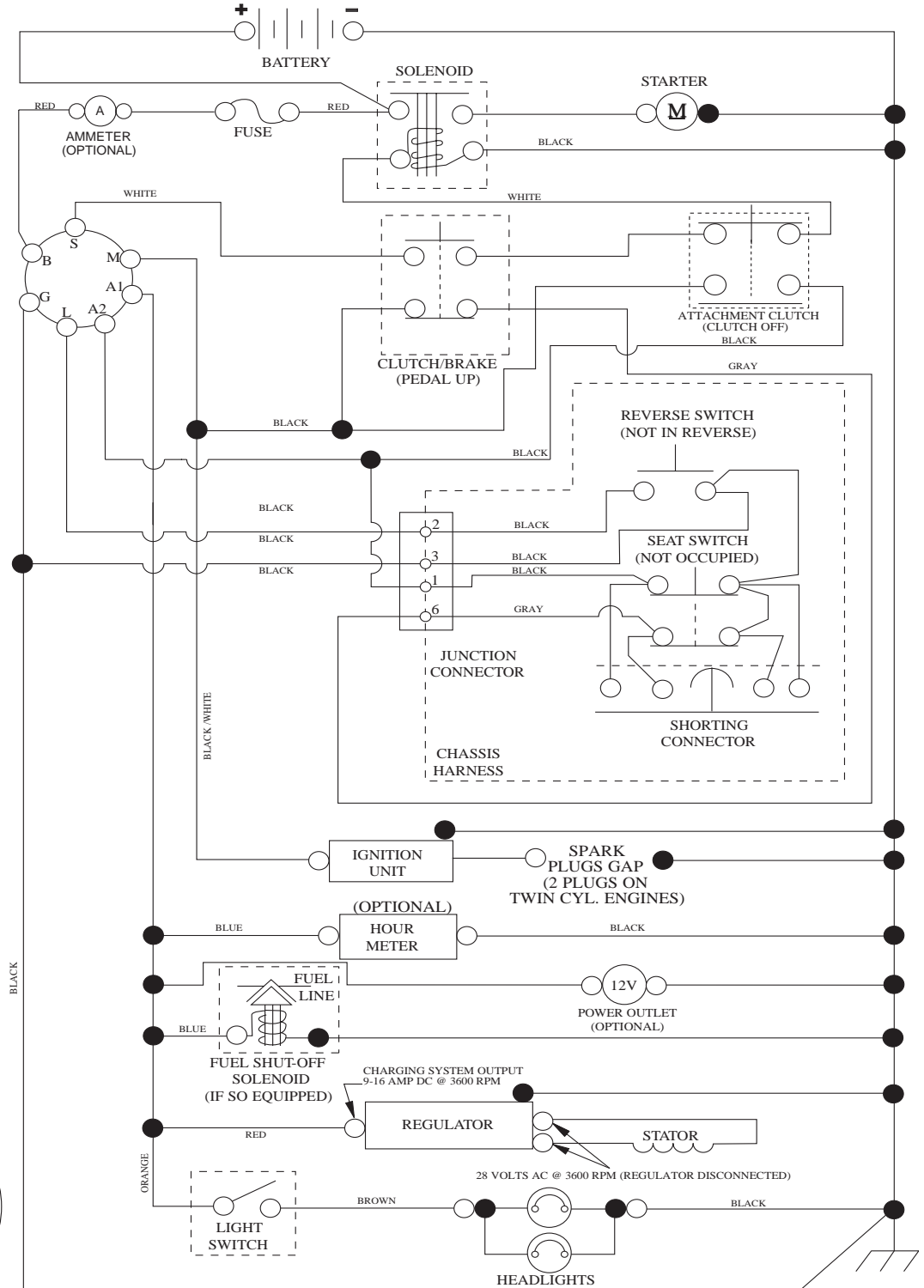

IGNITION SWITCH

POSITION	CIRCUIT	"MAKE"
OFF	M+G+A1	
RUN/OVERRIDE	B+A1	
RUN	B+A1	L+A2
START	B + S + A1	

03107

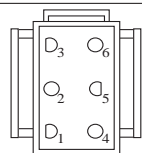

CHASSIS HARNESS CONNECTOR (MATING SIDE)

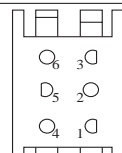

DASH HARNESS CONNECTOR (MATING SIDE)

WIRING INSULATED CLIPS
NOTE: IF WIRING INSULATED CLIPS WERE REMOVED FOR SERVICING OF UNIT, THEY SHOULD BE RE-INSTALLED TO PROPERLY SECURE YOUR WIRING.

●
NON-REMOVABLE CONNECTIONS

○
REMOVABLE CONNECTIONS

**TRACTOR -- MODEL NUMBER YTH20K46 (96043003300), PRODUCT NO. 960 43 00-33
ELECTRICAL**

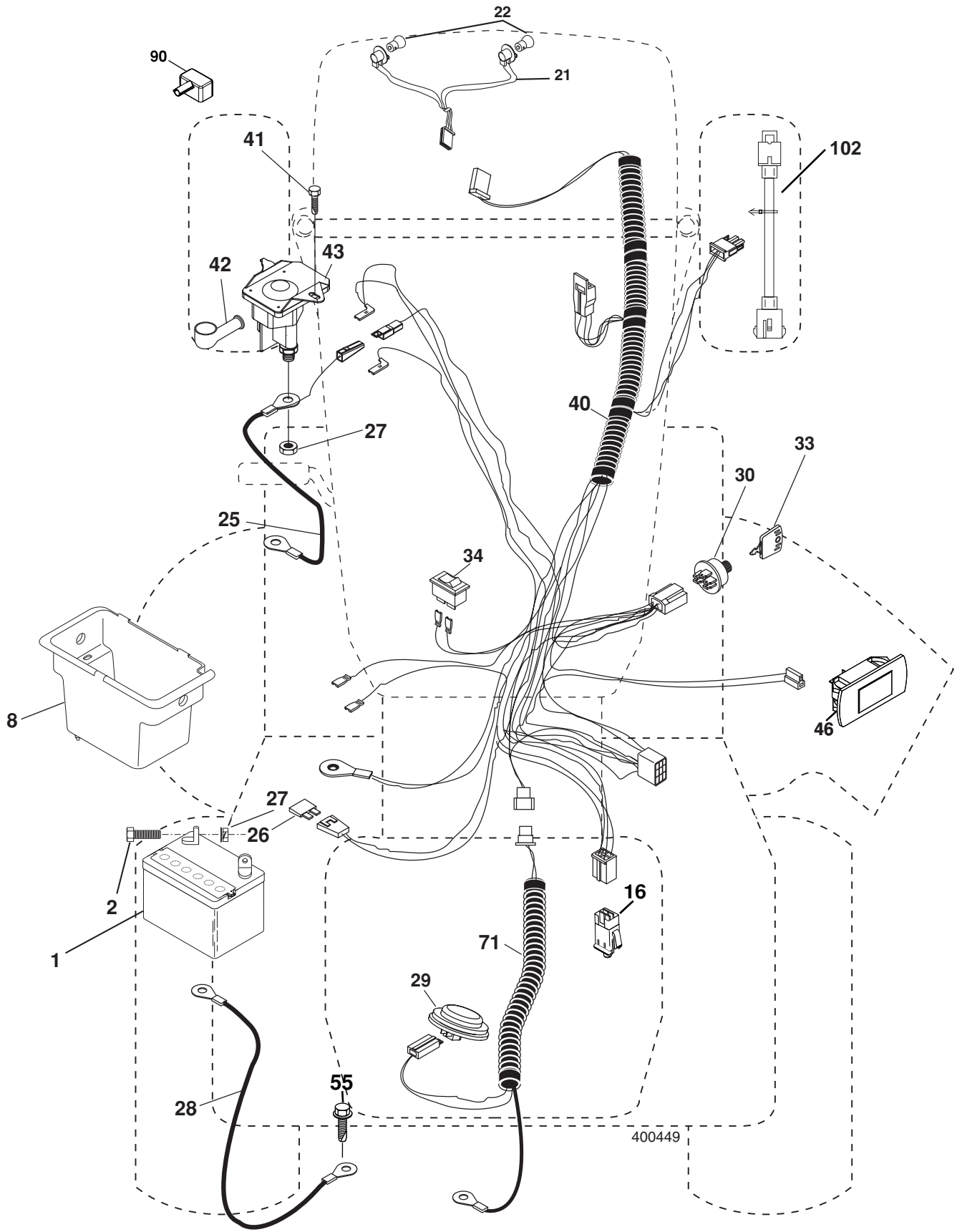

400449

**TRACTOR - - MODEL NUMBER YTH20K46 (96043003300), PRODUCT NO. 960 43 00-33
ELECTRICAL**

KEY NO.	PART NO.	DESCRIPTION
1	532 16 34-65	Battery
2	874 76 04-12	Bolt Hex Head 1/4-20 x 3/4
8	532 19 32-28	Box Battery
16	532 17 61-38	Switch Interlock Push-In
21	532 18 37-59	Harness Socket Light W/4152J
22	532 00 41-52	Bulb Light
25	532 19 88-93	Cable Starter
26	532 17 51-58	Fuse
27	873 51 04-00	Nut Keps Hex 1/4-20 unc
28	532 19 88-85	Cable, Ground
29	532 40 15-45	Switch, Seat
30	532 19 33-50	Switch, Ign
33	532 14 04-01	Key, Ignition
34	532 11 07-12	Switch Light / Reset
40	532 40 10-98	Harness Ign.
41	817 72 04-08	Screw Thd Cut 1/4-20 x 1/2
42	532 13 15-63	Cover, Terminal
43	532 19 25-07	Solenoid
46	532 40 17-63	Gauge Servicere minder Hrmtr
55	817 06 05-12	Screw Thdrol 5/16-18 x 3/4 TYTT
71	532 40 04-49	Harness Ign. Dash
90	532 40 07-25	Cover Terminal
102	532 40 44-54	Harness Pigtail

NOTE: All component dimensions given in U.S. inches
1 inch = 25.4 mm

**TRACTOR -- MODEL NUMBER YTH20K46 (96043003300), PRODUCT NO. 960 43 00-33
CHASSIS**

KEY NO.	PART NO.	DESCRIPTION	KEY NO.	PART NO.	DESCRIPTION
3	532 40 50-12	Logo	195	532 40 41-37	Plug Hole Dash Lower
4	532 19 93-48	Logo	196	532 40 28-43	Console Asm. Deck Lift
5	532 40 87-03	Dash	202	532 40 30-48	Vent Side Hood RH
6	532 40 48-83	Clip	203	532 40 30-76	Vent Side Hood LH
14	532 41 10-46	Hood	204	532 19 89-04	Vent Top Hood
15	532 19 89-07	Lens LH	205	532 40 17-09	Skirt Hood Side RH
18	532 40-48-21	Grille/Lens Asm.	206	532 40 17-11	Skirt Hood Side LH
25	532 19 89-06	Lens RH	207	532 19 71-98	Bezel RH
34	532 19 61-25	Plate Engine	208	532 19 71-99	Bezel LH
36	817 06 05-12	Screw 5/16-18 x 3/4	209	532 19 91-30	Insert Hex Top RH
37	532 40 47-94	Fender	210	532 19 91-31	Insert Hex Top Lh
52	873 68 05-00	Nut Lock 5/16-18	211	532 19 91-32	Insert Hex Bottom RH
68	817 49 05-08	Screw Thdrol 5/16-18 x 1/2	212	532 19 91-33	Insert Hex Bottom LH
99	532 40 59-03	Rod Asm Bypass	213	874 76 05-12	Bolt 5/16-18 x 3/4
130	532 19 16-11	Screw 10 x 3/4 Single Lead-Hex	214	532 19 91-45	Clip Retainer Tinner
137	532 40 75-90	Bumper Dash	217	532 15 65-24	Rod Pivot
138	532 40 29-54	Cupholder	218	532 19 63-95	X-Piece Hood Stop
150	532 19 85-13	Air Duct	222	532 13 77-29	Screw Thdrol 1/4-20 x 5/8
152	532 19 95-35	Shield Browning	228	532 19 51-61	Stud Fastner
162	532 14 24-32	Screw	230	532 17 01-65	Bolt Shoulder 5/16-18
175	532 19 63-04	Crossmember	234	532 40 47-42	Bumper Hood
176	532 40 07-76	Screw 10-24 x 5/8	235	532 40 61-29	Spacer Fender
177	532 19 52-27	Bushing Steering	236	873 93 05-00	Nut Lock 5/16-18 UNC
178	532 19 97-82	Cargo Net Asm.	238	532 40 86-06	Trim
180	532 19 54-57	Chassis	239	532 11 04-52	Nut, Push
181	532 40 30-25	Bushing Mtg. Fender Crgo			
182	532 19 47-87	Dash Lower			
183	874 78 05-20	Bolt Fin Hex 5/16-18 unc x 1-1/4			
189	817 00 05-12	Screw 5/16-18 x 3/4			
194	873 90 05-00	Nut Lock Hex Flange 5/16-18			

NOTE: All component dimensions given in U.S. inches
1 inch = 25.4 mm

**TRACTOR -- MODEL NUMBER YTH20K46 (96043003300), PRODUCT NO. 960 43 00-33
DRIVE**

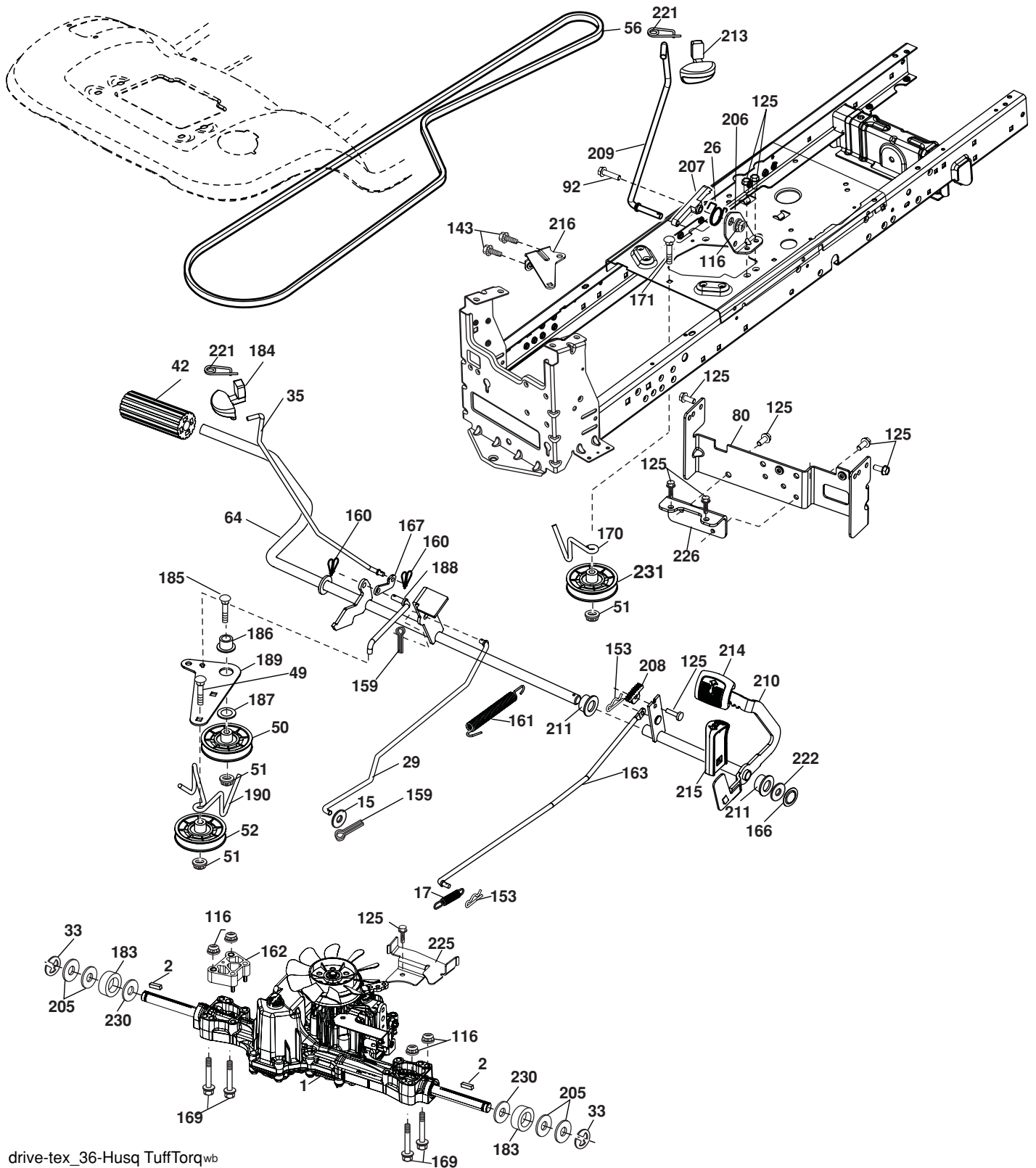

drive-tex_36-Husq TuffTorqwb

**TRACTOR -- MODEL NUMBER YTH20K46 (96043003300), PRODUCT NO. 960 43 00-33
DRIVE**

KEY NO.	PART NO.	DESCRIPTION	KEY NO.	PART NO.	DESCRIPTION
1	532405384	Transaxle, TUFFTORQ K46 (Order Parts from Transaxle Manufacturer)	170	532 19 43-22	Keeper Belt Centerspan
2	532 12 35-83	Key Square	171	872 11 06-16	Bolt
15	819 13 13-16	Washer 13/32 x 13/16 x 16 Ga.	183	532 13 70-57	Spacer Axle
17	532 41 36-78	Spring, Brake	184	532 40 31-18	Handle Parking Brake
26	532 19 96-79	Spring Return Cruise	185	872 11 06-20	Bolt
29	532 40 38-06	Rod, Brake	186	532 19 43-21	Spacer Retainer
33	812 00 00-01	Ring E	187	819 13 32-10	Washer
35	532 19 95-91	Rod, Brake, Park	188	532 19 43-23	Link Clutch Ground Drive
42	532 12 48-72	Cover, Foot Pedal	189	532 19 43-17	Bellcrank Ground Drive
49	872 11 06-14	Bolt	190	532 19 43-18	Keeper Bellcrank Ground Drive
50	532 19 43-27	Pulley Idler Flat	205	532 12 17-48	Washer 25/32 x 1-5/8 16 Ga.
51	873 90 06-00	Lock Nut 3/8-16	206	532 19 78-67	Bracket Mount Latch Cruise
52	532 19 43-26	Idler V-Groove 910" Offset	207	532 19 78-68	Latch Control Cruise
56	532 13 09-69	V-Belt, Drive	208	532 19 78-69	Gear Sector Control Cruise
64	532 19 78-65	Shaft Asm. Pedal Brake Control	209	532 19 95-92	Rod Control Cruise
80	532 41 00-24	Strap Torque	210	532 40 09-80	Rockr Asm. Pedal Control
92	874 76 05-20	Bolt Fin Hex 5/16-18 unc x 1.25	211	532 12 01-83	Bearing Nylon
116	873 90 05-00	Nut Lock Hex Flange 5/16-18	213	532 40 31-19	Knob control Cruise
125	817 00 05-12	Screw 5/16-18 x 3/4	214	532 40 17-22	Pad Pedal Forward
143	817 49 05-08	Screw 5/16-18 x 1/2	215	532 40 17-23	Pad Pedal Reverse
153	532 12 47-88	Retainer Spring	216	532 19 61-31	Bracket Pulley Idler
159	876 02 04-12	Pin Cotter 1/8 x 3/4	221	532 40 31-87	Retainer Spring Clip
160	532 16 94-84	Retainer Clip	222	879 21 20-10	Washer 21/32 x 1-1/4 10 Ga.
161	532 19 54-03	Spring, Return, Clutch	225	532 40 33-19	Keeper Bolt Transaxle
162	532 19 57-85	Spacer Transaxle	226	532 40 15-64	Bracket Mount Torque
163	532 40 10-34	Rod Pedal Control	230	532 18 89-67	Washer Hardened
166	532 19 72-90	Nut Push	231	532 40 72-87	Idler V-Groove 1.688" OFFSET
167	532 40 52-57	Latch Brake Parking			
169	874 49 05-60	Bolt Hex 5/16-18 x 3.75			

NOTE: All component dimensions given in U.S. inches
1 inch = 25.4 mm

TRACTOR -- MODEL NUMBER YTH20K46 (96043003300), PRODUCT NO. 960 43 00-33

STEERING ASSEMBLY

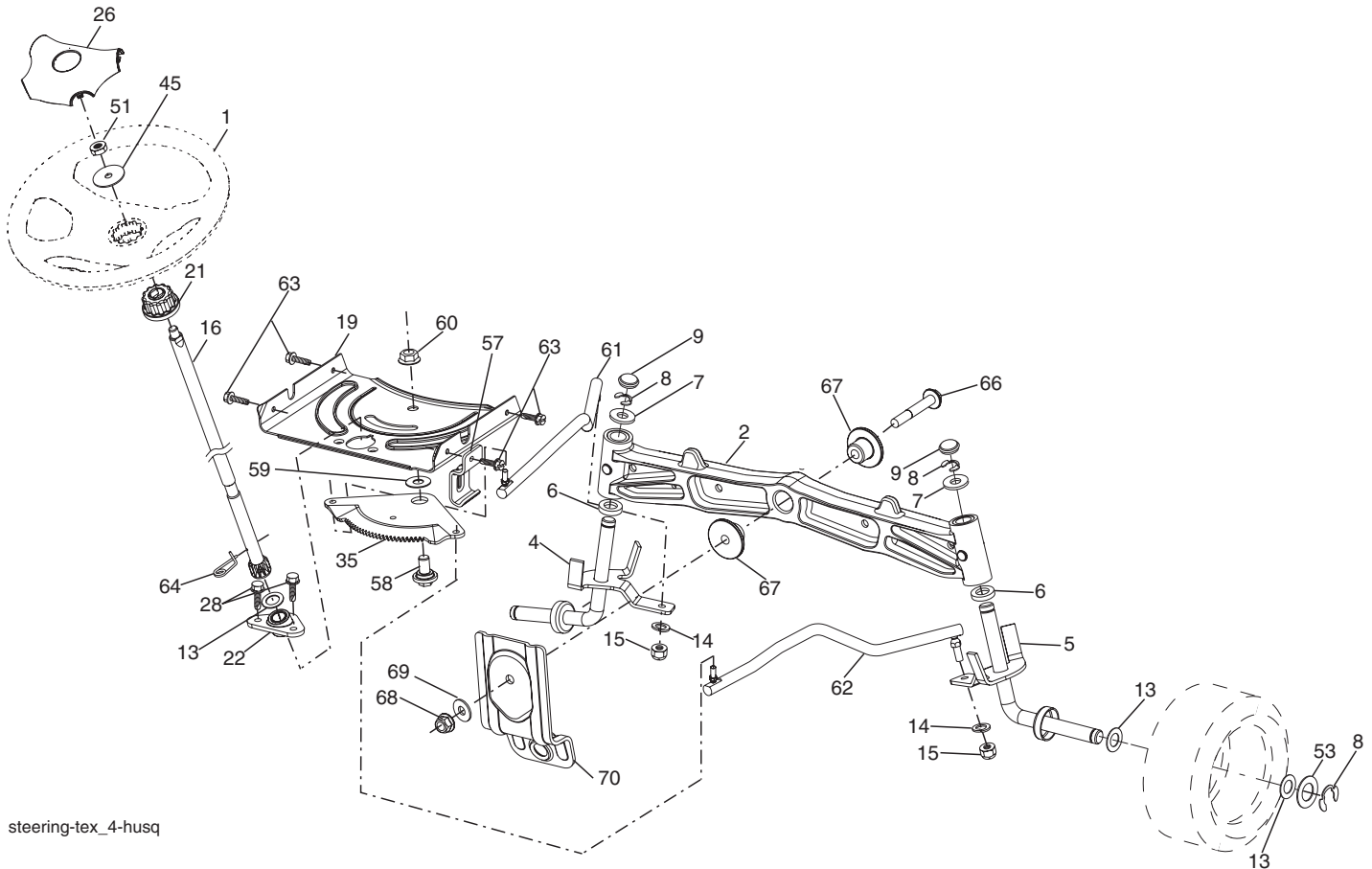

steering-tex_4-husq

KEY NO.	PART NO.	DESCRIPTION	KEY NO.	PART NO.	DESCRIPTION
1	532 19 39-43	Wheel, Steering	45	819 18 38-12	Washer 9/16 ID x 2-3/8 OD 12 Ga.
2	532 19 59-68	Axle Asm., Front	51	873 94 08-00	Nut Hex Jam Toplock 1/2-20 unf
4	532 40 30-87	Spindle Asm., LH	53	532 18 89-67	Washer Hardened .793x1.637x.060
5	532 40 30-88	Spindle Asm., RH	57	532 40 74-65	Bracket Upstop
6	532 12 49-31	Bearing, Race Thrust Harden	58	532 19 47-47	Bolt Shoulder Sector Pivot CFM
7	532 12 17-48	Washer 25/32 x 1-5/8 x 16 Ga.	59	532 19 47-48	Washer Thrust Sector Steering
8	812 00 00-29	Ring, Klip #T5304-75	60	873 97 10-00	Nut Flange Lock 5/8-11
9	532 12 12-32	Cap, Spindle	61	532 19 47-40	Draglink LH
13	532 12 17-49	Washer 25/32 x 1-1/4 x 16 Ga.	62	532 19 47-41	Draglink, RH
14	810 04 06-00	Washer, Lock Hvy Hlcl Spr 3/8	63	817 00 05-12	Screw 5/16-18 x 3/4
15	873 54 06-00	Nut, Crown Lock 3/8-24 unf	64	532 19 98-49	Retainer Clip Spring Steering
16	532 40 82-19	Shaft Steering	66	871 02 07-48	Bolt Hex Fghd 7/16-14 x 3 Serr
19	532 19 47-29	Plate Steering	67	532 19 47-37	Bushing PM Front Axle
21	532 18 67-37	Adapter, Wheel Steering	68	873 90 07-00	Nut Lock Flange 7/16-14 Gr. 5
22	532 19 48-45	Bushing, Strg. Blk	69	532 19 91-62	Washer 1.5 x .505 x .118
26	532 19 36-52	Insert, Wheel Steering	70	532 19 61-97	Bracket Deck Susp. Front
28	817 00 06-12	Screw 3/8-16 x 3/4			
35	532 19 47-32	Gear, Sector Plate			

NOTE: All component dimensions given in U.S. inches
1 inch = 25.4 mm

**TRACTOR -- MODEL NUMBER YTH20K46 (96043003300), PRODUCT NO. 960 43 00-33
ENGINE**

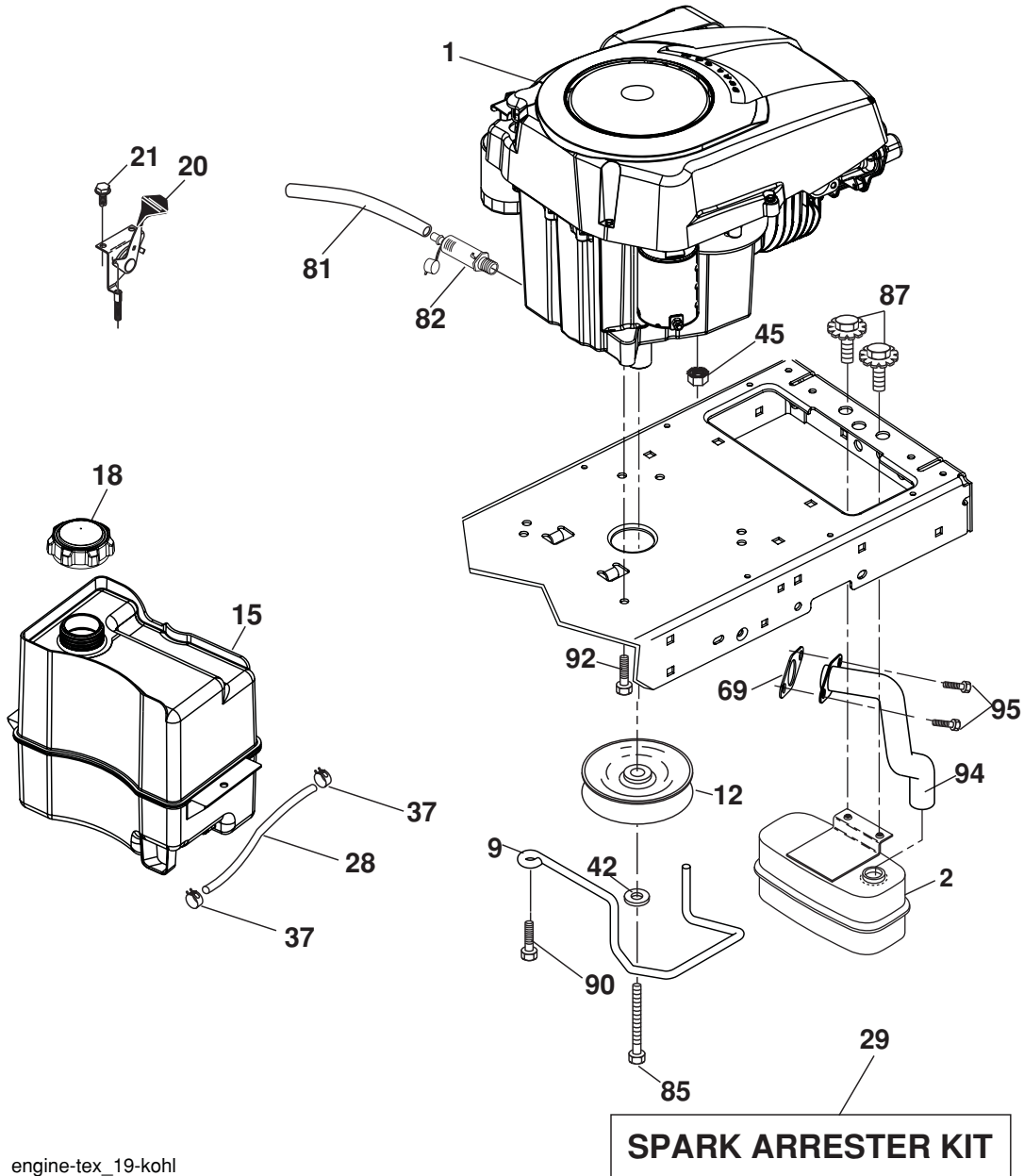

SPARK ARRESTER KIT

engine-tex_19-kohl

KEY NO.	PART NO.	DESCRIPTION
1	-----	Engine Kohler Model No. SV600
2	532 18 86-55	Muffler
9	532 19 43-20	Keeper Belt Engine
12	532 40 54-72	Pulley Engine
15	532 40 74-89	Tank Fuel
18	532 19 77-25	Cap Asm
20	532 40 15-08	Control Throttle
21	532 19 16-11	Screw 10 x 3/4 Single Lead Hex
28	532 40 11-37	Fuel Line
29	532 13 71-80	Spark Arrester Kit
37	532 12 34-87	Clamp Hose
42	810 04 07-00	Washer Lock 7/16
45	873 51 04-00	Nut Keps Hex 1/4-20 unc
69	532 18 59-09	Gasket
81	532 14 84-56	Tube Drain Oil Easy
82	532 18 16-54	Plug Drain Oil
85	532 17 39-37	Bolt Hex 7/16-20 x 4 x Gr. 5-1.5 Thr

KEY NO.	PART NO.	DESCRIPTION
87	537 17 18-77	Bolt 5/16-18 UNC x 3/4 w/Sems
90	817 00 06-16	Screw 3/8-16 x 1
92	817 12 06-16	Screw 3/8-16 x 1
94	532 18 86-54	Tube Exhaust
95	532 19 23-34	Screw Socket Hd. 5/16-18 x .75

NOTE: All component dimensions given in U.S. inches
1 inch = 25.4 mm

For engine service and replacement parts, call the toll free number for your engine manufacturer listed below:

Briggs & Stratton	1-800-233-3723
Kohler Co.	1-800-544-2444
Tecumseh Products	1-800-558-5402
Honda Engines	1-800-426-7701
Kawasaki	1-949-460-5688

**TRACTOR -- MODEL NUMBER YTH20K46 (96043003300), PRODUCT NO. 960 43 00-33
SEAT ASSEMBLY**

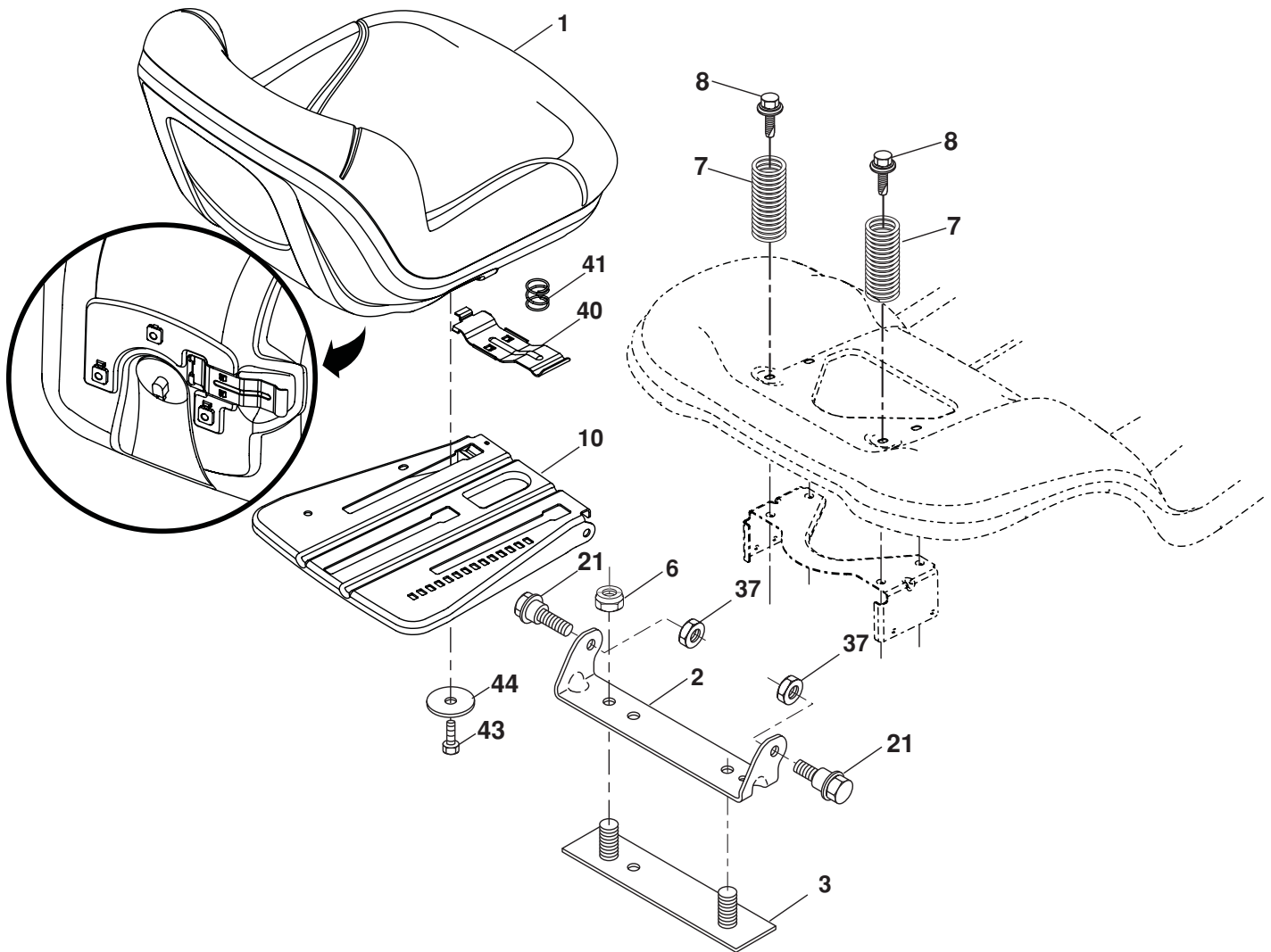

seat-tex_7-vgt

KEY NO.	PART NO.	DESCRIPTION
1	532 19 75-18	Seat
2	532 18 01-66	Bracket Pivot Fender
3	532 14 06-75	Strap, Asm Fender
6	873 80 06-00	Nut, Lock W/Ins. 3/8-16 unc
7	532 12 41-81	Spring, Seat Cprsn
8	532 17 18-77	Bolt 5/16-18 uncx 3/4 w/Sems
10	532 19 69-77	Pan, Seat
21	532 17 18-52	Bolt, Shoulder 5/16-18

KEY NO.	PART NO.	DESCRIPTION
37	873 80 05-00	Nut, Lock 5/16-18 unc
40	532 19 76-61	Handle Slide Seat
41	532 19 82-00	Spring Latch Seat
43	874 76 06-12	Bolt Fin Hex 3/8-16 unc x 3/4
44	819 13 38-12	Washer 13/32 x 2-3/8 x 12 Ga.

NOTE: All component dimensions given in U.S. inches
1 inch = 25.4 mm

**TRACTOR -- MODEL NUMBER YTH20K46 (96043003300), PRODUCT NO. 960 43 00-33
DECALS**

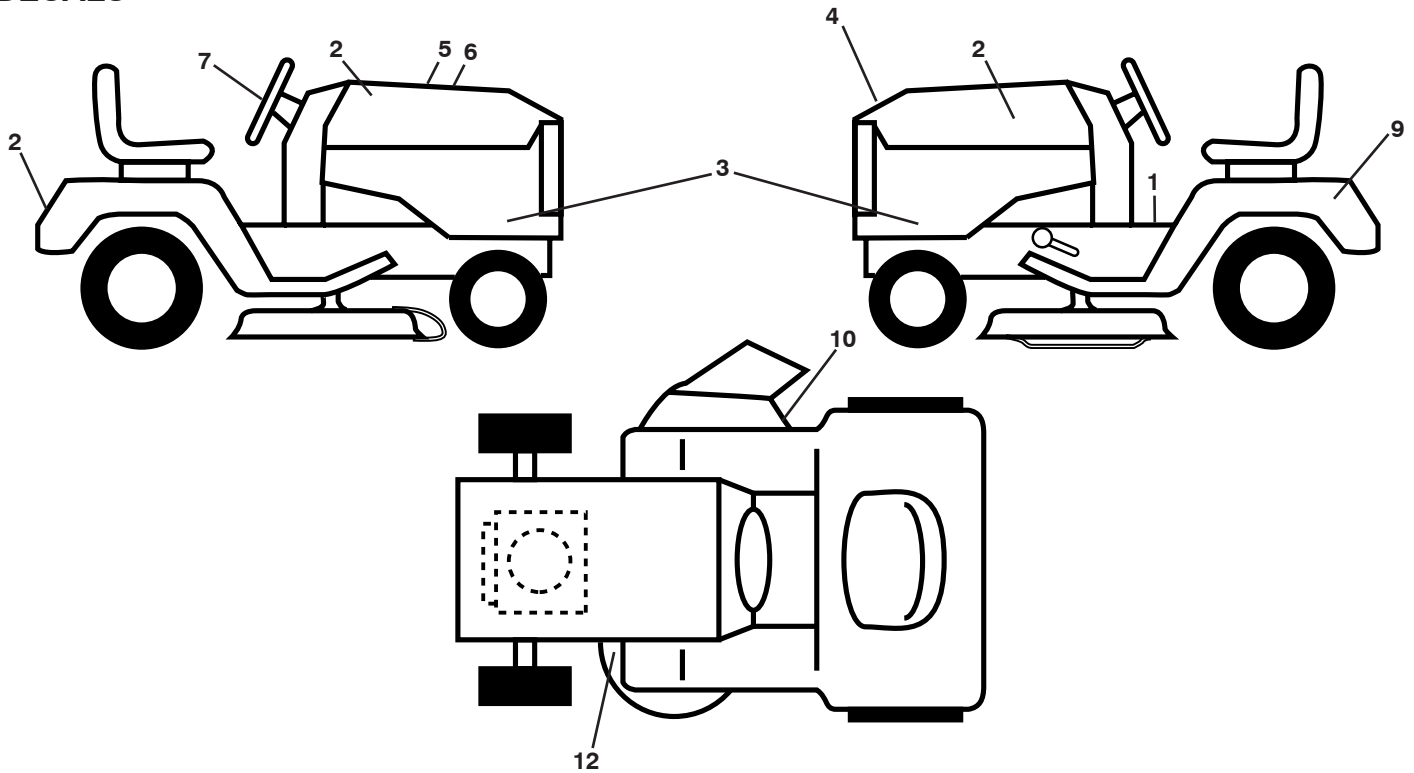

KEY NO.	PART NO.	DESCRIPTION
1	532 41 16-58	Decal, Warning
2	532 40 28-32	Decal, Hood
3	532 41 01-08	Decal, Hood Panel SD
4	532 40 21-28	Decal, Hood Top Insert
5	532 18 09-41	Decal, Customer Respons.
6	532 41 00-27	Decal, Replacement
7	532 40 44-84	Decal, Steering Wheel

KEY NO.	PART NO.	DESCRIPTION
9	532 14 50-05	Decal, Battery Dnge/Poi
10	532 17 05-63	Decal, Warning
12	532 16 03-96	Decal, Mower V-Belt Schematic
--	532 16 69-60	Decal, Bypass
--	532 41 08-05	Pad, Footrest, LH
--	532 41 08-06	Pad, Footrest, RH
--	532 41 04-50	Manual, Owner's (English)
--	532 41 04-51	Manual, Owner's (French)

WHEELS AND TIRES

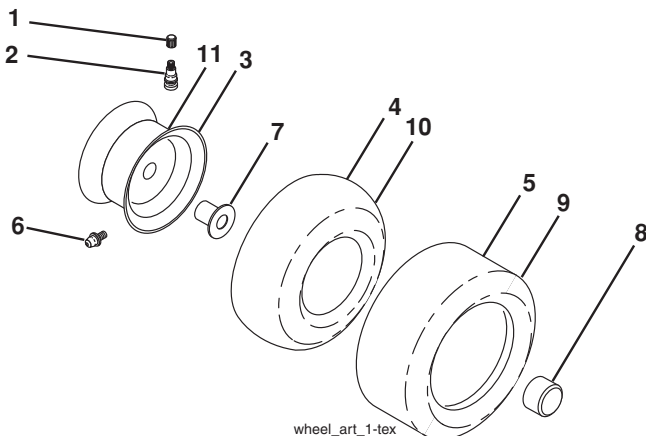

KEY NO.	PART NO.	DESCRIPTION
1	532 05 91-92	Cap Valve Tire
2	532 06 51-39	Stem Valve
3	532 13 83-36	Rim Front Service
4	532 05 99-04	Tube Front (Service Item Only)
5	532 10 62-22	Tire Front 15 x 6.0-6 Service
6	532 12 49-57	Fitting Grease (Front Wheel Only)
7	532 12 49-59	Bearing Flange (Front Wheel Only)
8	532 17 50-39	Cap Axle Blk 1 50 x 1 00
9	532 10 62-68	Tire R T 18 x 9.5-8 Service
10	532 12 49-26	Tube Rear (Service Item Only)
11	532 13 83-37	Rim Asm 8" rear Service
--	532 14 43-34	Sealant, Tire (10 oz. Tube)

NOTE: All component dimensions given in U.S. inches
1 inch = 25.4 mm

TRACTOR -- MODEL NUMBER YTH20K46 (96043003300), PRODUCT NO. 960 43 00-33
MOWER DECK

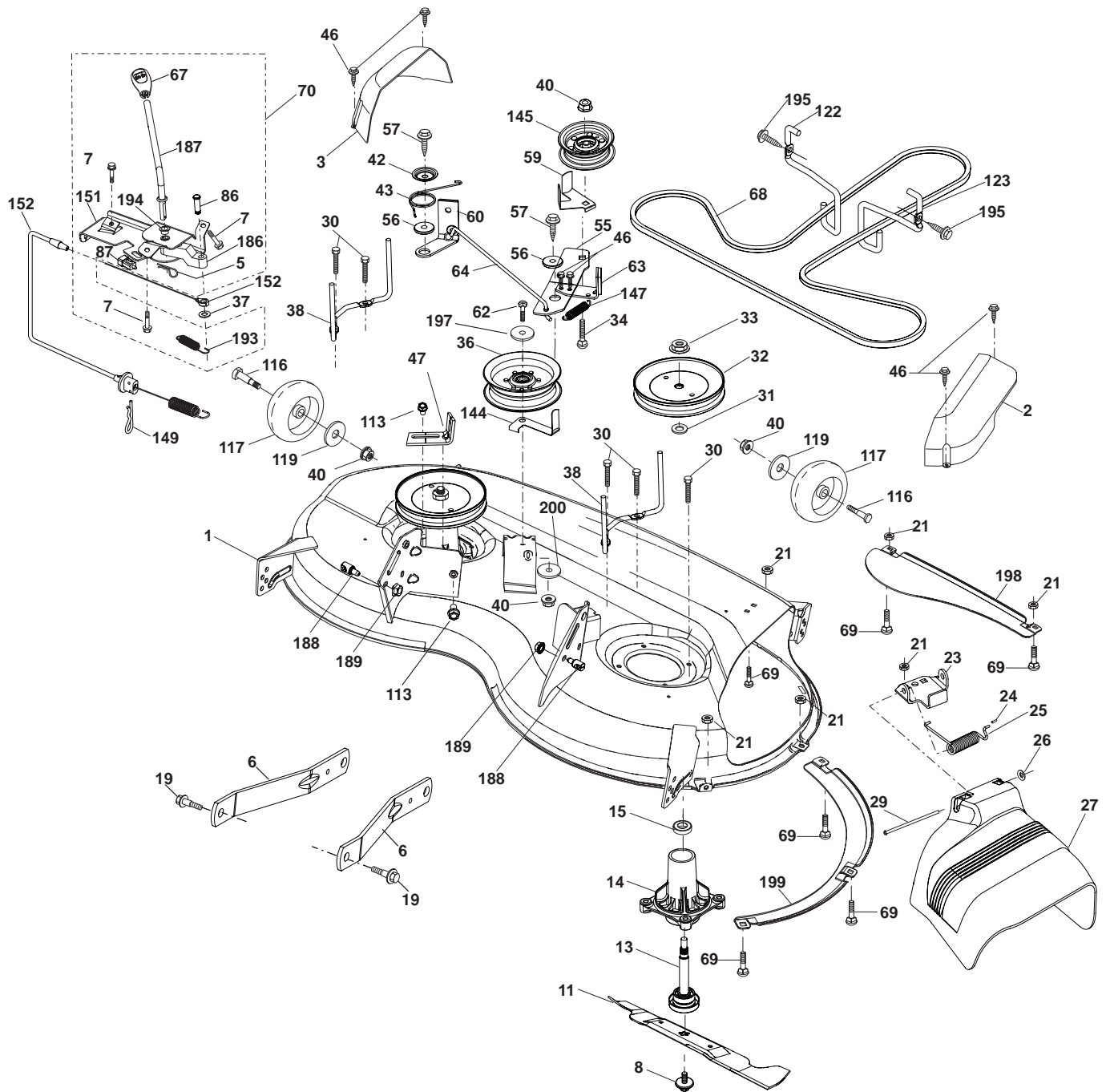

46_tex_lt_pred_3

**TRACTOR -- MODEL NUMBER YTH20K46 (96043003300), PRODUCT NO. 960 43 00-33
MOWER DECK**

KEY PART NO. NO.	DESCRIPTION	KEY PART NO. NO.	DESCRIPTION
1	532 41 08-63	63	532 19 94-78
2	532 40 55-06	64	532 40 51-39
3	532 40 55-07	67	532 40 30-12
5	532 12 46-70	68	532 40 51-43
6	532 19 51-86	69	872 14 05-05
7	532 19 16-11	70	532 40 65-63
8	532 19 30-03	86	532 19 77-98
11	532 40 53-80	87	532 19 78-02
13	532 19 28-72	113	817 00 05-10
14	532 18 72-81	116	532 19 34-06
15	532 11 04-85	117	532 17 48-73
19	532 19 65-39	119	819 13 20-12
21	873 68 05-00	122	532 19 72-58
23	532 19 25-57	123	532 19 72-59
24	532 10 53-04	144	532 19 92-04
25	532 19 70-26	145	532 17 79-68
26	532 11 04-52	147	532 40 18-72
27	532 40 53-57	149	532 16 58-98
29	532 13 14-91	151	532 40 65-60
30	532 17 39-84	152	532 40 83-19
31	532 18 76-90	186	532 19 77-99
32	532 19 59-45	187	532 40 65-62
33	532 40 02-34	188	532 19 51-61
34	872 11 06-12	189	873 90 05-00
36	532 19 61-06	193	532 19 78-01
37	819 13 13-16	194	532 19 77-97
38	532 19 91-89	195	817 00 06-12
40	873 90 06-00	197	819 13 13-12
42	532 19 84-10	198	532 40 31-49
43	532 19 72-56	199	532 40 31-50
46	532 13 77-29	200	819 13 32-10
47	532 19 72-50		
55	532 19 72-49	--	532 19 28-70
56	532 19 90-92		
57	817 00 06-16		
59	532 14 10-43	--	532 40 84-78
60	532 40 01-32		
62	874 52 06-36		

NOTE: All component dimensions given in U.S. inches
1 inch = 25.4 mm

**TRACTOR -- MODEL NUMBER YTH20K46 (96043003300), PRODUCT NO. 960 43 00-33
MOWER LIFT**

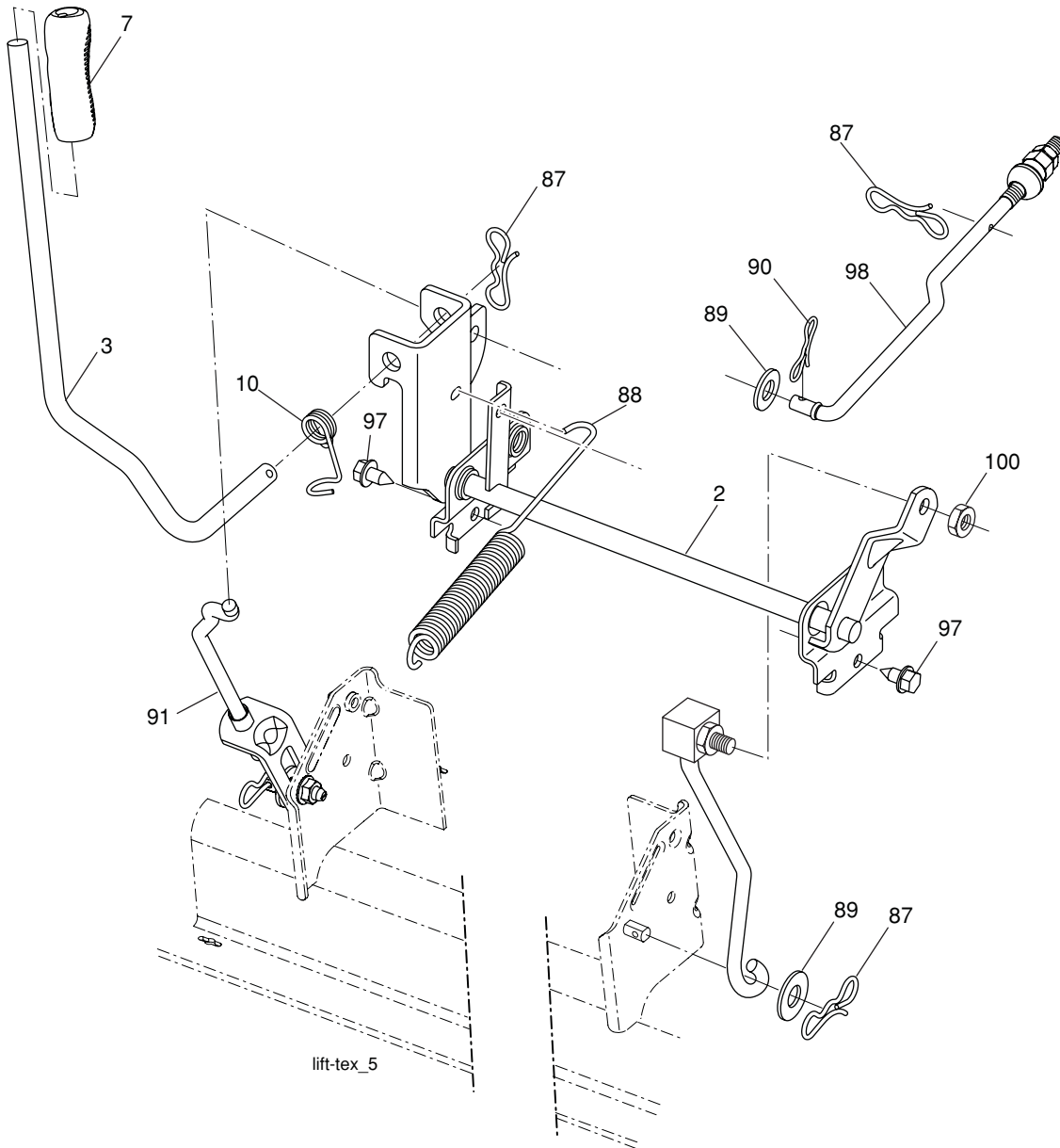

KEY NO.	PART NO.	DESCRIPTION
2	532 19 52-23	Shaft Asm., Lift
3	532 19 52-31	Lever Asm., Lift Rh
7	532 19 64-92	Grip, Lever
10	532 19 63-14	Spring Torsion
87	532 19 42-09	Pin Cotter 7/16 Bow Tie Lock
88	532 19 53-03	Spring Lift Assist
89	819 19 19-12	Washer Clear Zinc

KEY NO.	PART NO.	DESCRIPTION
90	532 19 42-08	Pin Cotter 5/16 Bow Tie Lock
91	532 19 51-81	Link Lift Susp Mower Rear
97	817 06 06-12	Screw 3/8-16x.75 Smgml Tap/R.Z
98	532 19 52-70	Link Lift Susp. Front Mower
100	873 93 06-00	Nut Center Lock 3/8-16 UNC

NOTE: All component dimensions given in U.S. inches
1 inch = 25.4 mm